

THIS DRAWING IS UNPUBLISHED. RELEASED FOR PUBLICATION
 © COPYRIGHT BY TYCO ELECTRONICS CORPORATION. ALL RIGHTS RESERVED.

LOC		DIST		REVISIONS			
P	LTR	DESCRIPTION		DATE	DWN	APVD	
F		ECR-12-007088		17APR2012	SY	AC	

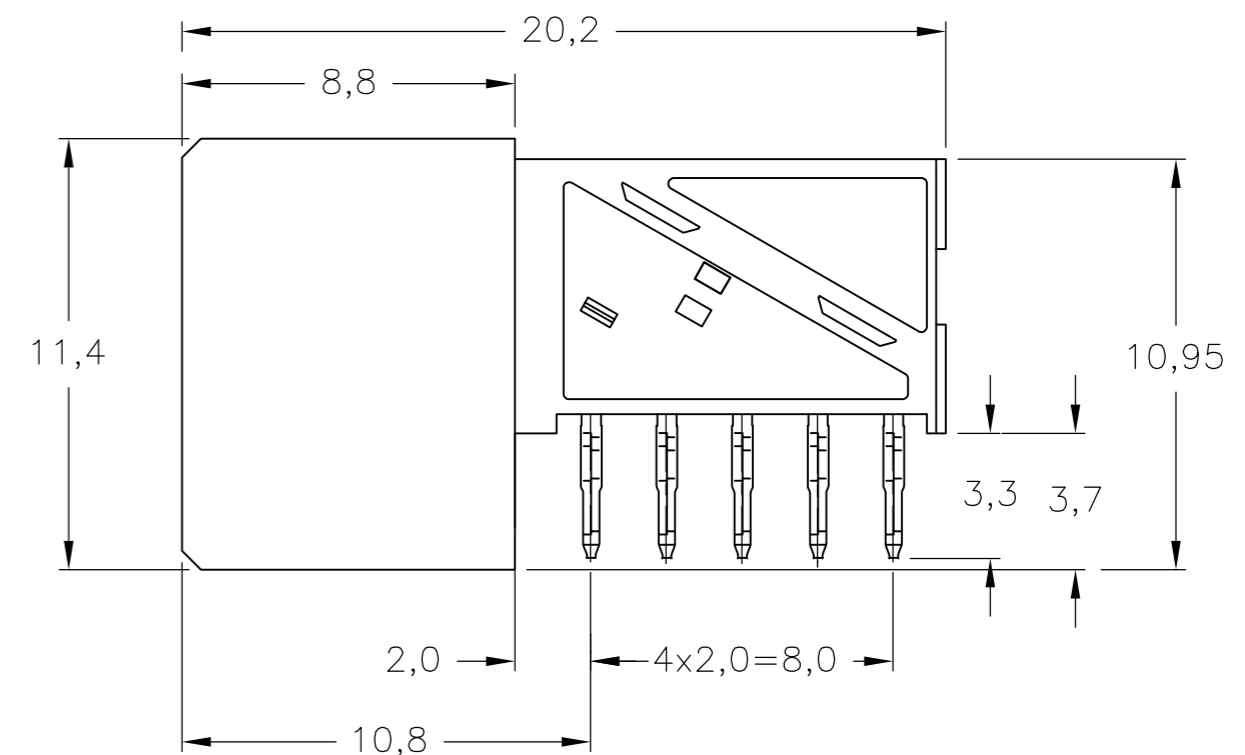
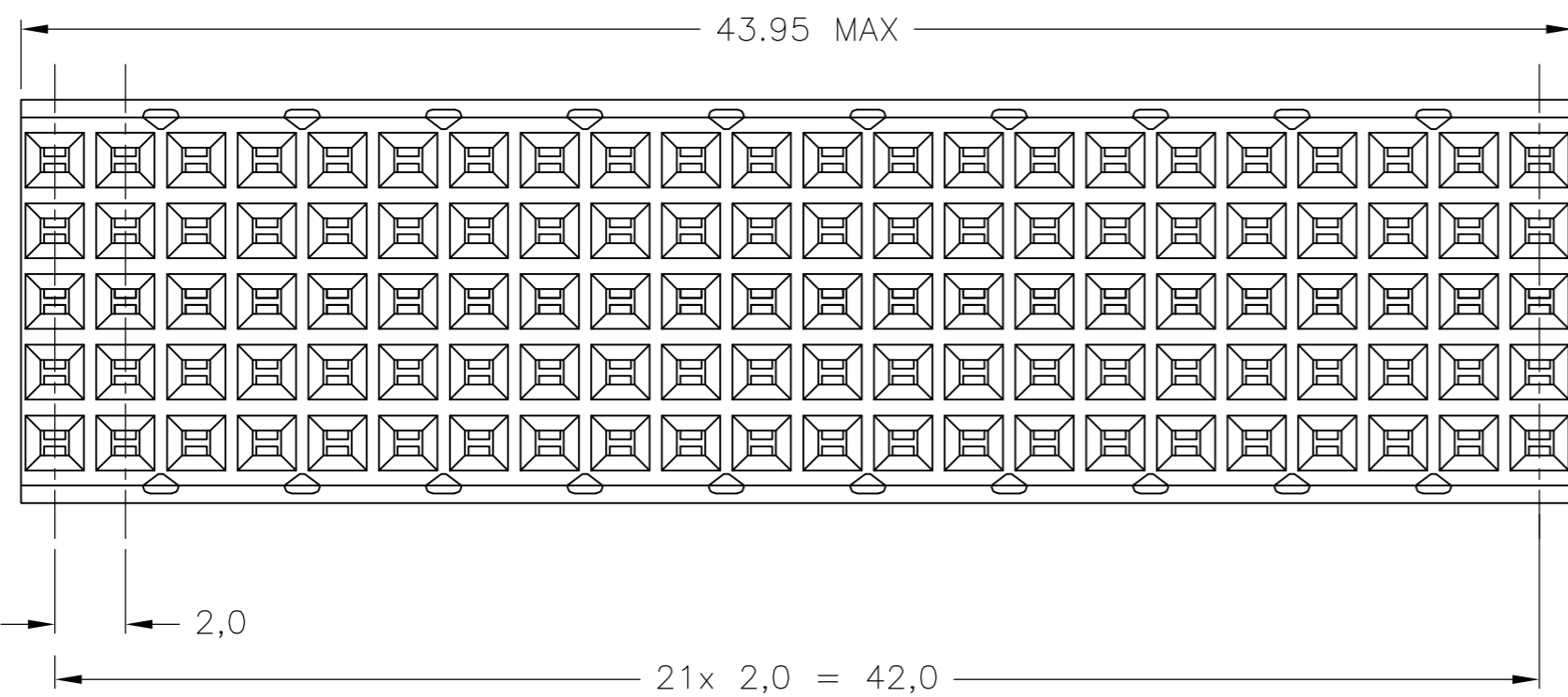
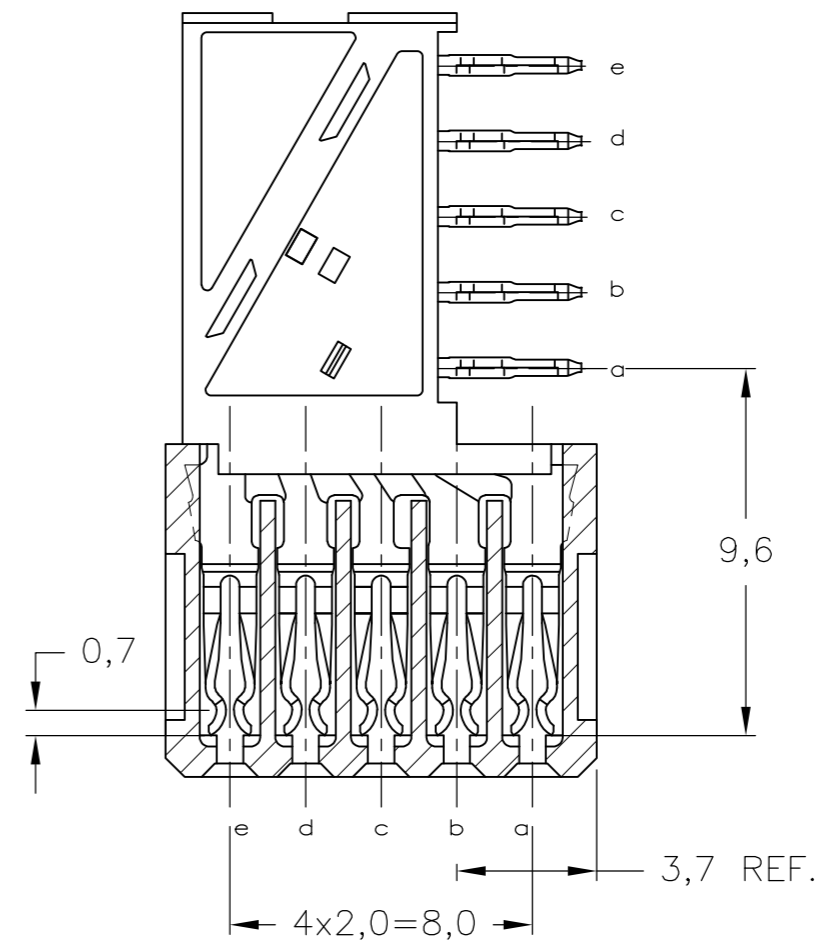
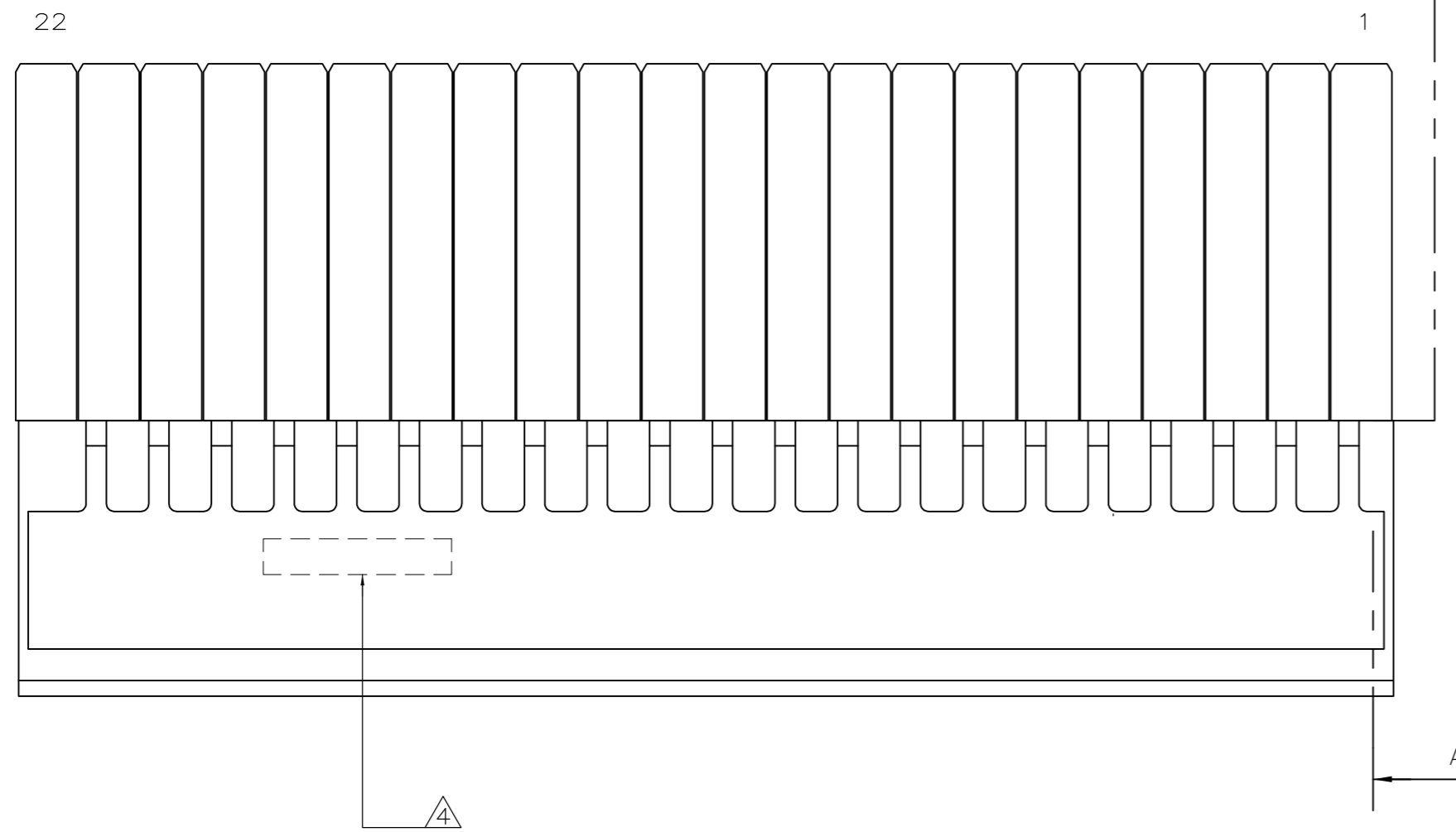

NOTES:

- 1 MATERIAL CONTACT; PHOSPHORBRONZE
MATERIAL HOUSING; GLASSFILLED POLYESTER (GRAY)
UL-RATING 94VO.
- 2 GENERAL PLATING SPECIFICATION: UNDERPLATING
(ENTIRE CONTACT): 1,27µm NICKEL MIN. AND ACTION
PIN: 0,5µm TIN MIN.
FOR PLATING OF MATING SURFACES SEE APPLICABLE
SPECIFICATION REFERENCE FOR EACH DASH NUMBER.
- 3 CONFORMS TO ALL TESTING ACCORDING IEC 61076-4-101
PERFORMANCE LEVEL 2.
- 4 CONNECTOR PRINTED WITH PARTNUMBER AND DATECODE
- 5 PLATED-THROUGH HOLES AT 2x2mm
SQUARE GRID. 110 HOLES
- 6 FITS WITH INTEGRATED GROUND RETURN UPPERSHIELD
BASIC P.N. 5352151
- 7 0.76µm MIN. GOLD PLATING AT MATING SURFACES.
- 8 CONNECTOR TESTED AND QUALIFIED AGAINST TELCORDIA,
GR-1217-CORE QUALITY LEVEL III, CENTRAL OFFICE APPLICATIONS.

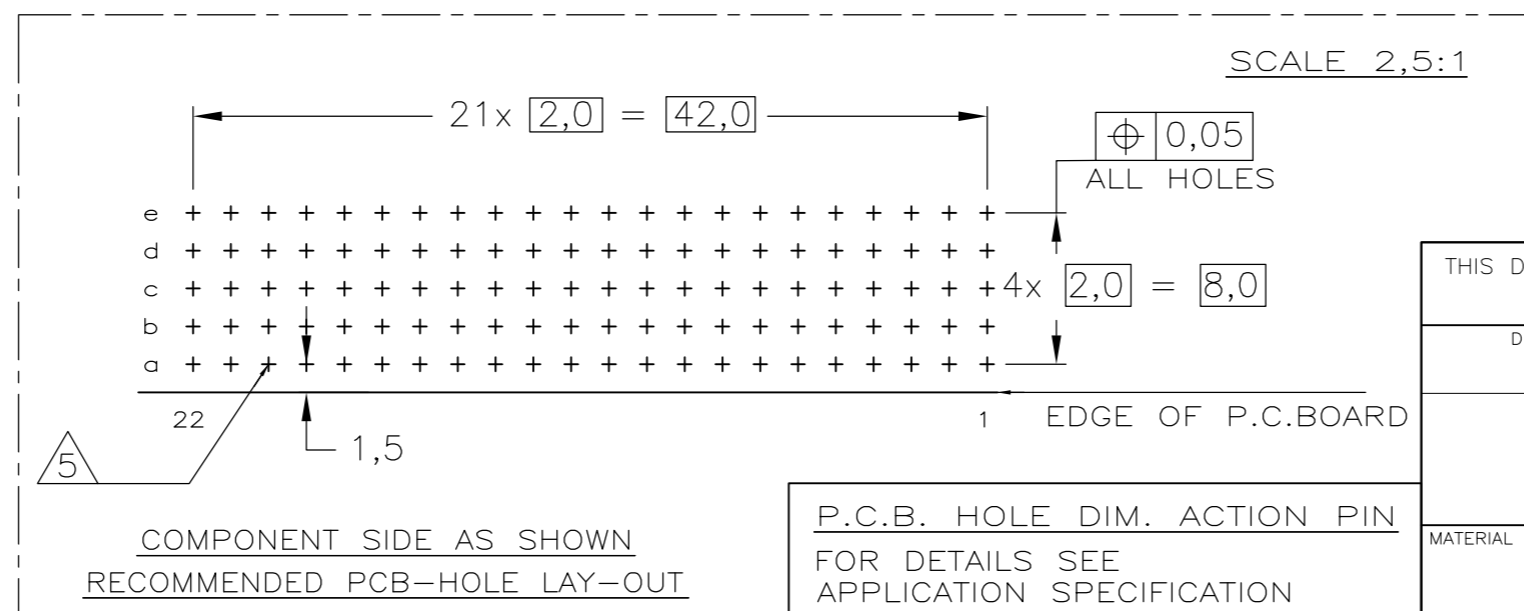

THIS DRAWING IS A CONTROLLED DOCUMENT.

DIMENSIONS:	TOLERANCES UNLESS OTHERWISE SPECIFIED:
mm	±0.2
MATERIAL	FINISH
-	-

DWN	13AUG2004	3-5188836-0	
CHK	22MAR2005	5188836-9	
APVD	22MAR2005	5188836-1	
PRODUCT SPEC	B.MOOIJ	FINISH	MATERIAL
APPLICATION SPEC	108-19082	PARTNUMBER	
WEIGHT	114-19029	NAME	
CUSTOMER DRAWING	-	Tyco Electronics Corporation 's-Hertogenbosch,5222AR-32	
SCALE	5:1	Z-PACK 2mm HM 110 POS. FEMALE DAUGHTER CARD CONN. (22 COLUMNS)	
SHEET	1 OF 1	SIZE	RESTRICTED TO
REV	F	A2	-