

Single Channel 16-bit CIS/CCD AFE with 4-bit Wide Output

DESCRIPTION

The WM8152 is a 16-bit analogue front end/digitiser IC which processes and digitises the analogue output signals from CCD sensors or Contact Image Sensors (CIS) at pixel sample rates of up to 12MSPS.

The device includes a complete analogue signal processing channel containing Reset Level Clamping, Correlated Double Sampling, Programmable Gain and Offset adjust functions. Internal multiplexers allow fast switching of offset and gain for line-by-line colour processing. The output from this channel is time multiplexed into a high-speed 16-bit Analogue to Digital Converter. The digital output data is available in 4-bit wide multiplexed format.

An internal 4-bit DAC is supplied for internal reference level generation. This may be used to reference CIS signals or during Reset Level Clamping to clamp CCD signals. An external reference level may also be supplied. ADC references are generated internally, ensuring optimum performance from the device.

Using an analogue supply voltage of 5V, a digital core voltage of 5V, and a digital interface supply of either 5V or 3.3V, the WM8152 typically only consumes 225mW when operating from a single 5V supply.

FEATURES

- 16-bit ADC
- 12MSPS conversion rate
- Low power - 225mW typical
- 5V single supply or 5V/3.3V dual supply operation
- Single channel operation
- Correlated double sampling
- Programmable gain (8-bit resolution)
- Programmable offset adjust (8-bit resolution)
- Programmable clamp voltage
- 4-bit wide multiplexed data output format
- Internally generated voltage references
- 20-lead SSOP package
- Serial control interface

APPLICATIONS

- Flatbed and sheetfeed scanners
- USB compatible scanners
- Multi-function peripherals
- High-performance CCD sensor interface

BLOCK DIAGRAM

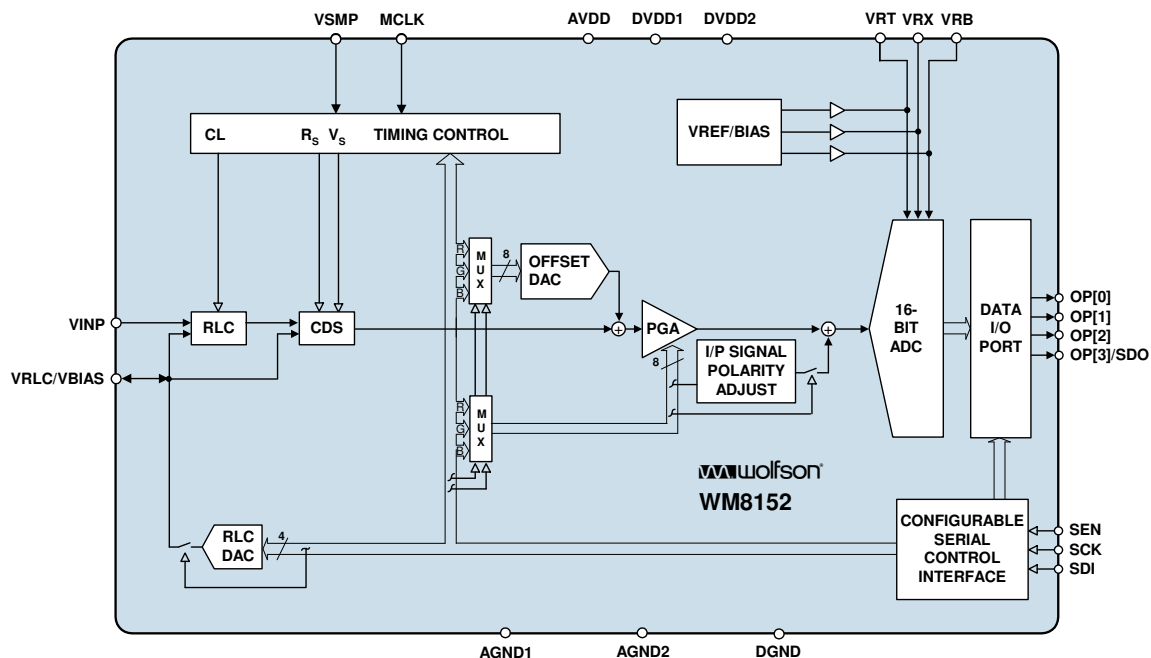
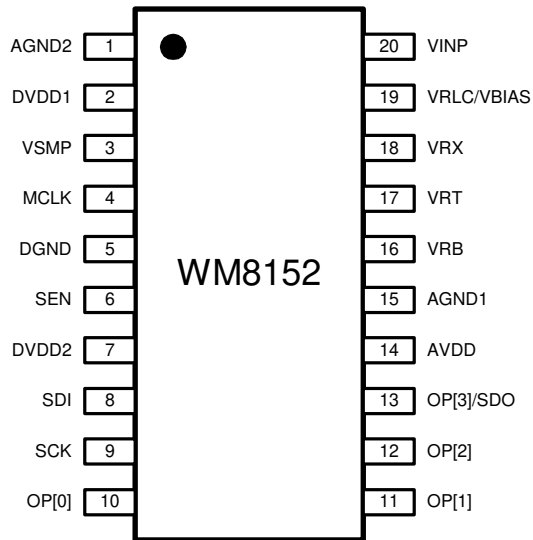

TABLE OF CONTENTS

DESCRIPTION	1
FEATURES	1
APPLICATIONS	1
BLOCK DIAGRAM	1
TABLE OF CONTENTS	2
PIN CONFIGURATION	3
ORDERING INFORMATION	3
PIN DESCRIPTION	4
ABSOLUTE MAXIMUM RATINGS	5
RECOMMENDED OPERATING CONDITIONS	6
THERMAL PERFORMANCE	6
ELECTRICAL CHARACTERISTICS	7
INPUT VIDEO SAMPLING	9
OUTPUT DATA TIMING.....	10
SERIAL INTERFACE	11
INTERNAL POWER ON RESET CIRCUIT	12
DEVICE DESCRIPTION	14
INTRODUCTION	14
INPUT SAMPLING	14
RESET LEVEL CLAMPING (RLC)	14
CDS/NON-CDS PROCESSING	16
OFFSET ADJUST AND PROGRAMMABLE GAIN	16
ADC INPUT BLOCK LEVEL ADJUST	17
OVERALL SIGNAL FLOW SUMMARY	17
CALCULATING OUTPUT FOR ANY GIVEN INPUT.....	18
OUTPUT DATA FORMAT	19
CONTROL INTERFACE.....	20
TIMING REQUIREMENTS	21
PROGRAMMABLE VSMP DETECT CIRCUIT.....	21
REFERENCES.....	22
POWER SUPPLY.....	22
POWER MANAGEMENT	22
OPERATING MODES	22
OPERATING MODE TIMING DIAGRAMS.....	23
DEVICE CONFIGURATION	25
REGISTER MAP	25
REGISTER MAP DESCRIPTION.....	26
APPLICATIONS INFORMATION	28
RECOMMENDED EXTERNAL COMPONENTS	28
RECOMMENDED EXTERNAL COMPONENTS VALUES.....	29
PACKAGE DIMENSIONS	30
IMPORTANT NOTICE	31
REVISION HISTORY	32

PIN CONFIGURATION



ORDERING INFORMATION

DEVICE	TEMPERATURE RANGE	PACKAGE	PEAK SOLDERING TEMPERATURE
WM8152SCDS/V	0 to 70°C	20-lead SSOP (Pb free)	260°C
WM8152SCDS/RV	0 to 70°C	20-lead SSOP (Pb free, tape and reel)	260°C

Note:

Reel quantity = 2,000

PIN DESCRIPTION

PIN	NAME	TYPE	DESCRIPTION																				
1	AGND2	Supply	Analogue ground (0V).																				
2	DVDD1	Supply	Digital core (logic and clock generator) supply (5V)																				
3	VSMP	Digital input	Video sample synchronisation pulse.																				
4	MCLK	Digital input	Master clock. This clock is applied at N times the input pixel rate (N = 2, 3, 6, 8 or any multiple of 2 thereafter depending on input sample mode).																				
5	DGND	Supply	Digital ground (0V).																				
6	SEN	Digital input	Enables the serial interface when high.																				
7	DVDD2	Supply	Digital supply (5V/3.3V), all digital I/O pins.																				
8	SDI	Digital input	Serial data input.																				
9	SCK	Digital input	Serial clock.																				
			Digital multiplexed output data bus. ADC output data (d15:d0) is available in 4-bit multiplexed format as shown below.																				
			<table border="1" style="width: 100%; border-collapse: collapse;"> <thead> <tr> <th style="width: 25%;">A</th> <th style="width: 25%;">B</th> <th style="width: 25%;">C</th> <th style="width: 25%;">D</th> </tr> </thead> <tbody> <tr> <td>d12</td> <td>d8</td> <td>d4</td> <td>d0</td> </tr> <tr> <td>d13</td> <td>d9</td> <td>d5</td> <td>d1</td> </tr> <tr> <td>d14</td> <td>d10</td> <td>d6</td> <td>d2</td> </tr> <tr> <td>d15</td> <td>d11</td> <td>d7</td> <td>d3</td> </tr> </tbody> </table>	A	B	C	D	d12	d8	d4	d0	d13	d9	d5	d1	d14	d10	d6	d2	d15	d11	d7	d3
A	B	C	D																				
d12	d8	d4	d0																				
d13	d9	d5	d1																				
d14	d10	d6	d2																				
d15	d11	d7	d3																				
10	OP[0]	Digital output																					
11	OP[1]	Digital output																					
12	OP[2]	Digital output																					
13	OP[3]/SDO	Digital output																					
			Alternatively, pin OP[3]/SDO may be used to output register read-back data when address bit 4=1 and SEN has been pulsed high. See Serial Interface description in Device Description section for further details.																				
14	AVDD	Supply	Analogue supply (5V)																				
15	AGND1	Supply	Analogue ground (0V).																				
16	VRB	Analogue output	Lower reference voltage. This pin must be connected to AGND via a decoupling capacitor.																				
17	VRT	Analogue output	Upper reference voltage. This pin must be connected to AGND via a decoupling capacitor.																				
18	VRX	Analogue output	Input return bias voltage. This pin must be connected to AGND via a decoupling capacitor.																				
19	VRLC/VBIAS	Analogue I/O	Selectable analogue output voltage for RLC or single-ended bias reference. This pin would typically be connected to AGND via a decoupling capacitor. VRLC can be externally driven if programmed Hi-Z.																				
20	VINP	Analogue input	Video input.																				

ABSOLUTE MAXIMUM RATINGS

Absolute Maximum Ratings are stress ratings only. Permanent damage to the device may be caused by continuously operating at or beyond these limits. Device functional operating limits and guaranteed performance specifications are given under Electrical Characteristics at the test conditions specified.



ESD Sensitive Device. This device is manufactured on a CMOS process. It is therefore generically susceptible to damage from excessive static voltages. Proper ESD precautions must be taken during handling and storage of this device.

CONDITION	MIN	MAX
Analogue supply voltage: AVDD	GND - 0.3V	GND + 7V
Digital core voltage: DVDD1	GND - 0.3V	GND + 7V
Digital IO supply voltage: DVDD2	GND - 0.3V	GND + 7V
Digital ground: DGND	GND - 0.3V	GND + 0.3V
Analogue grounds: AGND1 – 2	GND - 0.3V	GND + 0.3V
Digital inputs, digital outputs and digital I/O pins	GND - 0.3V	DVDD2 + 0.3V
Analogue input (VINP)	GND - 0.3V	AVDD + 0.3V
Other pins	GND - 0.3V	AVDD + 0.3V
Operating temperature range: T _A	0°C	+70°C
Storage temperature after soldering	-65°C	+150°C
Package body temperature (soldering, 10 seconds)		+260°C
Package body temperature (soldering, 2 minutes)		+183°C

Notes:

1. GND denotes the voltage of any ground pin.
2. AGND1, AGND2 and DGND pins are intended to be operated at the same potential. Differential voltages between these pins will degrade performance.

RECOMMENDED OPERATING CONDITIONS

CONDITION		SYMBOL	MIN	TYP	MAX	UNITS
Operating temperature range		T_A	0		70	°C
Analogue supply voltage		AVDD	4.75	5.0	5.25	V
Digital core supply voltage		DVDD1	4.75	5.0	5.25	V
Digital I/O supply voltage	5V I/O	DVDD2	4.75	5.0	5.25	V
	3.3V I/O	DVDD2	2.97	3.3	3.63	V

THERMAL PERFORMANCE

PARAMETER	SYMBOL	TEST CONDITIONS	MIN	TYP	MAX	UNIT
Performance						
Thermal resistance – junction to case	$R_{\theta JC}$	$T_{\text{ambient}} = 25^{\circ}\text{C}$		32.2		°C/W
Thermal resistance – junction to ambient	$R_{\theta JA}$			81.1		°C/W

Notes:

1. Figures given are for package mounted on 4-layer FR4 according to JESD51-5 and JESD51-7.

ELECTRICAL CHARACTERISTICS

Test Conditions

AVDD = DVDD1 = 5.0V, DVDD2 = 3.3V, AGND = DGND = 0V, T_A = 25°C, MCLK = 24MHz unless otherwise stated.

PARAMETER	SYMBOL	TEST CONDITIONS	MIN	TYP	MAX	UNIT
Overall System Specification (including 16-bit ADC, PGA, Offset and CDS functions)						
Full-scale input voltage range (see Note 1)		Max Gain Min Gain		0.30 3.22		V _{p-p} V _{p-p}
Input signal limits (see Note 2)	V _{IN}		0		VDD	V
Full-scale transition error		Gain = 0dB; PGA[7:0] = 07(hex)	-50	10	+50	mV
Zero-scale transition error		Gain = 0dB; PGA[7:0] = 07(hex)	-50	10	+50	mV
Differential non-linearity	DNL			1.25		LSB
Integral non-linearity	INL			25		LSB
Total output noise		Min Gain Max Gain		4.5 14		LSB rms LSB rms
References						
Upper reference voltage	VRT			2.70		V
Lower reference voltage	VRB			1.45		V
Input return bias voltage	VRX		1.55	1.65	1.75	V
Diff. reference voltage (VRT-VRB)	V _{RTB}		1.15	1.25	1.35	V
Output resistance VRT, VRB, VRX				1		Ω
VRLC/Reset-Level Clamp (RLC)						
RLC switching impedance			20	50	100	Ω
VRLC short-circuit current			1.86	2	4.5	mA
VRLC output resistance				2		Ω
VRLC Hi-Z leakage current		VRLC = 0 to AVDD			1	μA
RLCDAC resolution				4		bits
RLCDAC step size, RLCDAC = 0	V _{RLCSTEP}	AVDD = 5.0V	0.23	0.25	0.27	V/step
RLCDAC step size, RLCDAC = 1	V _{RLCSTEP}		0.14	0.16	0.20	V/step
RLCDAC output voltage at code 0(hex), RLCDACRNG = 0	V _{RLCBOT}	AVDD = 5.0V	0.34	0.39	0.44	V
RLCDAC output voltage at code 0(hex), RLCDACRNG = 1	V _{RLCBOT}		0.20	0.26	0.31	V
RLCDAC output voltage at code F(hex) RLCDACRNG, = 0	V _{RLCTOP}	AVDD = 5.0V	4.0	4.16	4.3	V
RLCDAC output voltage at code F(hex), RLCDACRNG = 1	V _{RLCTOP}		2.56	2.66	2.76	V
Offset DAC, Monotonicity Guaranteed						
Resolution				8		bits
Differential non-linearity	DNL			0.1	0.5	LSB
Integral non-linearity	INL			0.25	1	LSB
Step size				2.04		mV/step
Output voltage		Code 00(hex) Code FF(hex)	-247 +247	-260 +260	-273 +273	mV mV

Notes:

- Full-scale input voltage** denotes the peak input signal amplitude that can be gained to match the ADC input range.
- Input signal limits** are the limits within which the full-scale input voltage signal must lie.

Test Conditions

 AVDD = DVDD1 = 5.0V, DVDD2 = 3.3V, AGND = DGND = 0V, T_A = 25°C, MCLK = 24MHz unless otherwise stated.

PARAMETER	SYMBOL	TEST CONDITIONS	MIN	TYP	MAX	UNIT
Programmable Gain Amplifier						
Resolution				8		bits
Gain equation				$0.78 + \frac{\text{PGA}[7:0] \times 7.57}{255}$		V/V
Max gain	G _{MAX}		6.8	8.35	8.7	V/V
Min gain	G _{MIN}		0.75	0.78	0.82	V/V
Gain error				1	2	%
Internal channel offset	V _{OFF}			10		mV
Analogue to Digital Converter						
Resolution				16		bits
Maximum Speed			12			MSPS
Full-scale input range (2*(VRT-VRB))	V _{FS}			2.5		V
DIGITAL SPECIFICATIONS						
Digital Inputs						
High level input voltage	V _{IH}		0.7 * DVDD2			V
Low level input voltage	V _{IL}				0.2 * DVDD2	V
High level input current	I _{IH}				1	μA
Low level input current	I _{IL}				1	μA
Input capacitance	C _I			5		pF
Digital Outputs						
High level output voltage	V _{OH}	I _{OH} = 1mA	DVDD2 - 0.5			V
Low level output voltage	V _{OL}	I _{OL} = 1mA			0.5	V
Supply Currents						
Total supply current – active				45		mA
Total analogue AVDD, supply current – active	I _{AVDD}			41		mA
Total digital core, DVDD1, supply current – active	I _{DVDD1}			3		mA
Digital I/O supply current, DVDD2 – active (see note 3)	I _{DVDD2}			3		mA
Supply current – full power down mode				300	400	μA

Notes:

- Digital I/O supply current depends on the capacitive load attached to the pin. The Digital I/O supply current is measured with approximately 50pF attached to the pin.

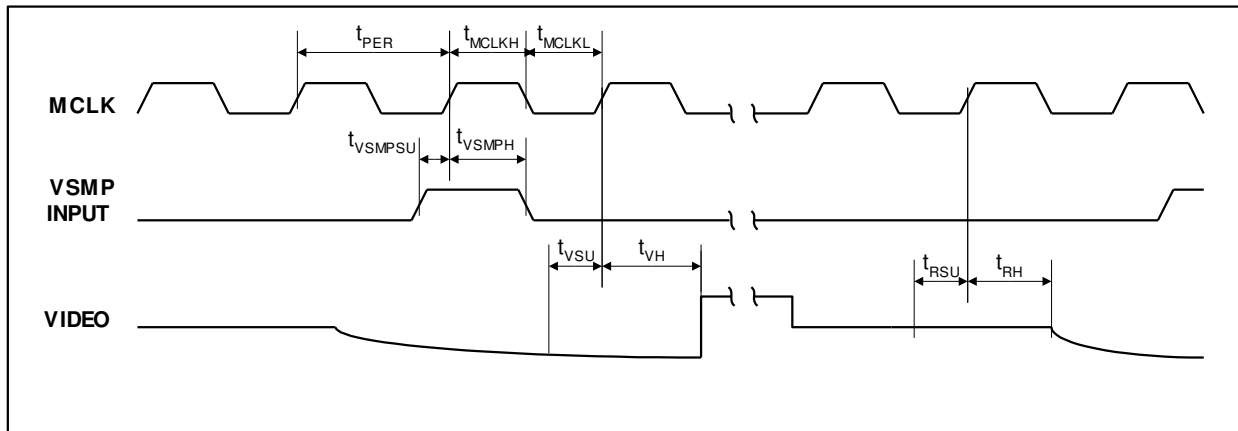
INPUT VIDEO SAMPLING

Figure 1 Input Video Timing
Note:

1. See Page 21 (Programmable VSMP Detect Circuit) for video sampling description.

Test Conditions

VDD = 5.0V, DVDD = 3.3V, AGND = DGND = 0V, $T_A = 25^\circ\text{C}$, MCLK = 24MHz unless otherwise stated.

PARAMETER	SYMBOL	TEST CONDITIONS	MIN	TYP	MAX	UNITS
MCLK period	t_{PER}		41.6			ns
MCLK high period	t_{MCLKH}		18.8			ns
MCLK low period	t_{MCLKL}		18.8			ns
VSMP set-up time	$t_{VSMP\ SU}$		6			ns
VSMP hold time	$t_{VSMP\ H}$		3			ns
Video level set-up time	t_{VSU}		10			ns
Video level hold time	t_{VH}		3			ns
Reset level set-up time	t_{RSU}		10			ns
Reset level hold time	t_{RH}		3			ns

Notes:

1. t_{VSU} and t_{RSU} denote the set-up time required after the input video signal has settled.
2. Parameters are measured at 50% of the rising/falling edge.

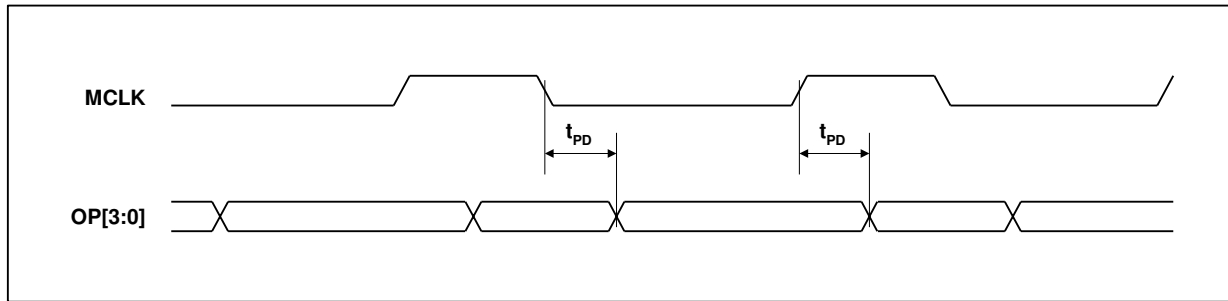
OUTPUT DATA TIMING

Figure 2 Output Data Timing
Test Conditions

VDD = 5.0V, DVDD = 3.3V, AGND = DGND = 0V, $T_A = 25^\circ\text{C}$, MCLK = 24MHz unless otherwise stated.

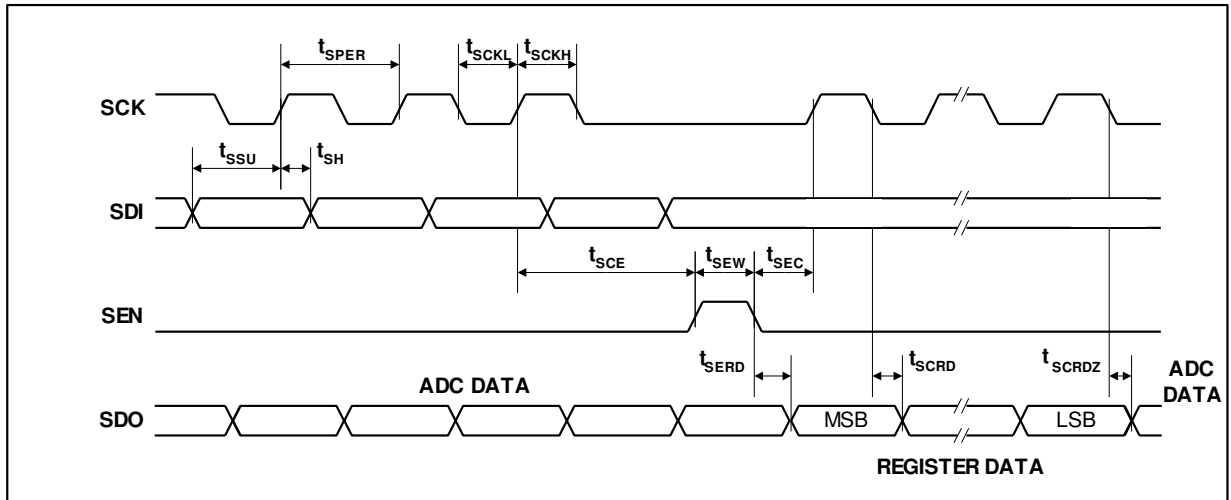
PARAMETER	SYMBOL	TEST CONDITIONS	MIN	TYP	MAX	UNITS
Output propagation delay	t_{PD}	$I_{OH} = 1\text{mA}$, $I_{OL} = 1\text{mA}$			20	ns

SERIAL INTERFACE

Figure 3 Serial Interface Timing
Test Conditions

VDD = 5.0V, DVDD = 3.3V, AGND = DGND = 0V, T_A = 25°C, MCLK = 24MHz unless otherwise stated.

PARAMETER	SYMBOL	TEST CONDITIONS	MIN	TYP	MAX	UNITS
SCK period	t _{SPER}		41.6			ns
SCK high	t _{SCKH}		18.8			ns
SCK low	t _{SCKL}		18.8			ns
SDI set-up time	t _{SSU}		6			ns
SDI hold time	t _{SH}		6			ns
SCK to SEN set-up time	t _{SCE}		12			ns
SEN to SCK set-up time	t _{SEC}		12			ns
SEN pulse width	t _{SEW}		25			ns
SEN low to SDO = Register data	t _{SERD}				30	ns
SCK low to SDO = Register data	t _{SCRD}				30	ns
SCK low to SDO = ADC data	t _{SCRDZ}				30	ns

Note:

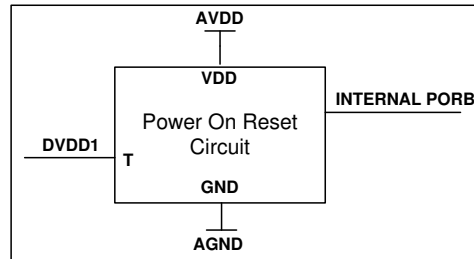
- Parameters are measured at 50% of the rising/falling edge

INTERNAL POWER ON RESET CIRCUIT

Figure 4 Internal Power On Reset Circuit Schematic

The WM8152 includes an internal Power-On-Reset Circuit, as shown in Figure 4, which is used to reset the digital logic into a default state after power up. The POR circuit is powered from AVDD and monitors DVDD1. It asserts PORB low if AVDD or DVDD1 is below a minimum threshold.

The power supplies can be brought up in any order but is important that either AVDD is brought up and is stable before DVDD comes up or vice versa as shown in Figure 5 and Figure 6.

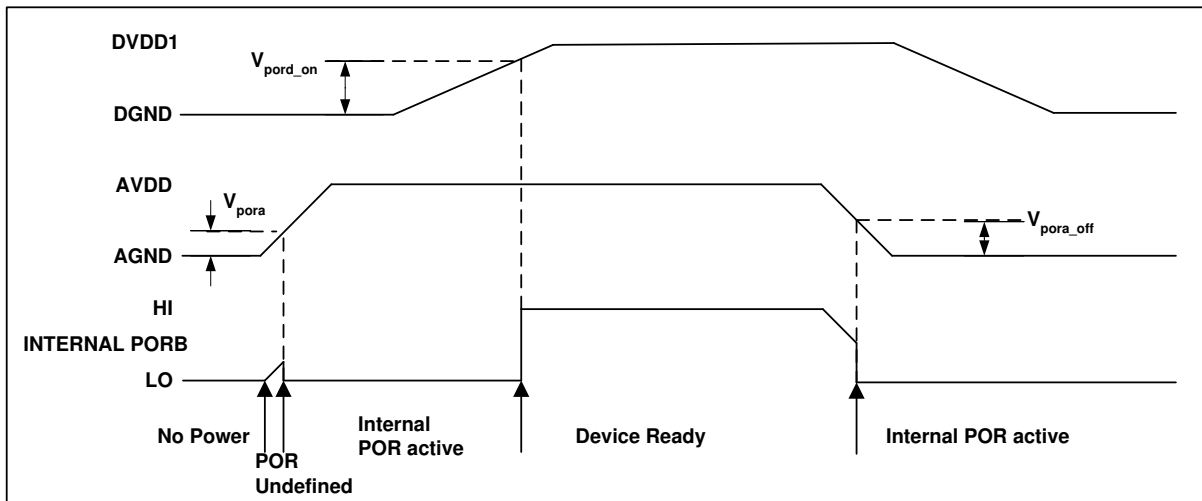

Figure 5 Typical Power up Sequence where AVDD is Powered before DVDD1

Figure 5 shows a typical power-up sequence where AVDD is powered up first. When AVDD rises above the minimum threshold, V_{pora} , there is enough voltage for the circuit to guarantee PORB is asserted low and the chip is held in reset. In this condition, all writes to the control interface are ignored. Now AVDD is at full supply level. Next DVDD1 rises to V_{pord_on} and PORB is released high and all registers are in their default state and writes to the control interface may take place.

On power down, where AVDD falls first, PORB is asserted low whenever AVDD drops below the minimum threshold V_{pora_off} .

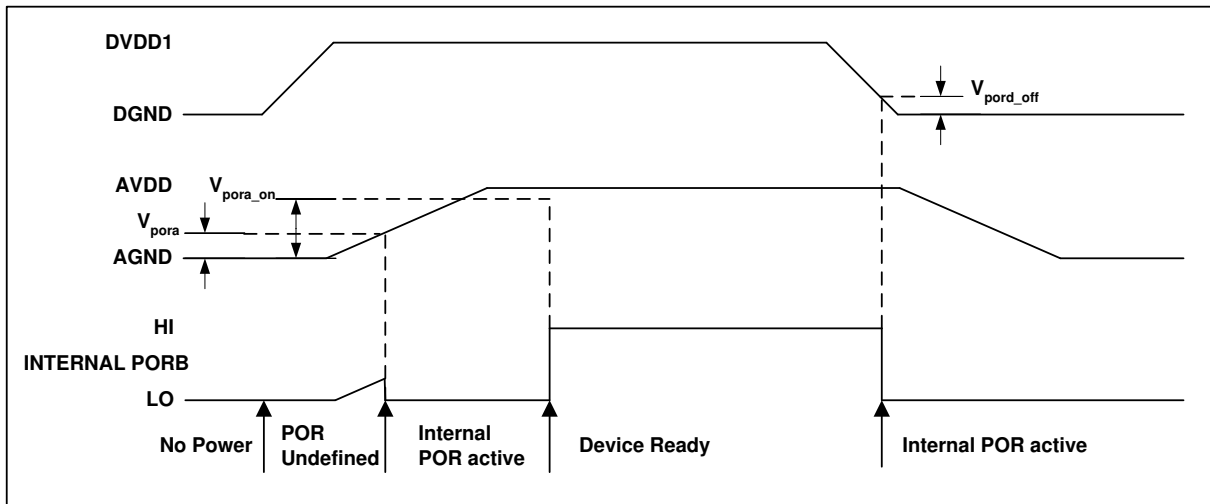

Figure 6 Typical Power up Sequence where DVDD1 is Powered before AVDD

Figure 6 shows a typical power-up sequence where DVDD1 is powered up first. It is assumed that DVDD1 is already up to specified operating voltage. When AVDD goes above the minimum threshold, V_{pora} , there is enough voltage for the circuit to guarantee PORB is asserted low and the chip is held in reset. In this condition, all writes to the control interface are ignored. When AVDD rises to V_{pora_on} , PORB is released high and all registers are in their default state and writes to the control interface may take place.

On power down, where DVDD1 falls first, PORB is asserted low whenever DVDD1 drops below the minimum threshold V_{pord_off} .

SYMBOL	TYP	UNIT
V_{pora}	0.6	V
V_{pora_on}	1.2	V
V_{pora_off}	0.6	V
V_{pord_on}	0.7	V
V_{pord_off}	0.6	V

Table 1 Typical POR Operation (typical values, not tested)

Note: It is recommended that every time power is cycled to the WM8199 a software reset is written to the software register to ensure that the contents of the control registers are at their default values before carrying out any other register writes.

DEVICE DESCRIPTION

INTRODUCTION

A block diagram of the device showing the signal path is presented on Page 1.

The WM8152 processes the sampled video signal on VINP with respect to the video reset level or an internally/externally generated reference level through the analogue processing channel.

This processing channel consists of an Input Sampling block with optional Reset Level Clamping (RLC) and Correlated Double Sampling (CDS), an 8-bit programmable offset DAC and an 8-bit Programmable Gain Amplifier (PGA).

The ADC then converts each resulting analogue signal to a 16-bit digital word. The digital output from the ADC is presented on a 4-bit wide bus.

On-chip control registers determine the configuration of the device, including the offsets and gains applied to each channel. These registers are programmable via a serial interface.

INPUT SAMPLING

The WM8152 has a single analogue processing channel and ADC which can be used in a flexible manner to process both monochrome and line-by-line colour inputs.

Monochrome: VINP is sampled, processed by the analogue channel, and converted by the ADC. The same offset DAC and PGA register values are always applied.

Colour Line-by-Line: VINP is sampled and processing by the analogue channel before being converted by the ADC. The gains and offset register values applied to the PGA and offset DAC can be switched between the independent Red, Green and Blue digital registers (e.g. Red → Green → Blue → Red...) at the start of each line in order to facilitate line-by-line colour operation. The INTM[1:0] bits determine which register contents are applied (see Table 2) to the PGA and offset DAC. By using the INTM[1:0] bits to select the desired register values only one register write is required at the start of each new colour line.

RESET LEVEL CLAMPING (RLC)

To ensure that the signal applied to the WM8152 VINP pin lies within the valid input range (0V to VDD) the CCD output signal is usually level shifted by coupling through a capacitor, C_{IN}. When active, the RLC circuit clamps the WM8152 side of this capacitor to a suitable voltage during the CCD reset period. The RLCINT register bit controls is used to activate the Reset Level Clamp circuit.

A typical input configuration is shown in Figure 7. The Timing Control Block generates an internal clamp pulse, CL, from MCLK and VSMP (when RLCINT is high). When CL is active the voltage on the WM8152 side of C_{IN}, at VINP, is forced to the VRLC/VBIAS voltage (V_{VRLC}) by closing switch 1. When the CL pulse turns off, switch 1 opens the voltage at VINP initially remains at V_{VRLC} but any subsequent variation in sensor voltage (from reset to video level) will couple through C_{IN} to VINP.

RLC is compatible with both CDS and non-CDS operating modes, as selected by switch 2. Refer to the CDS/non-CDS Processing section.

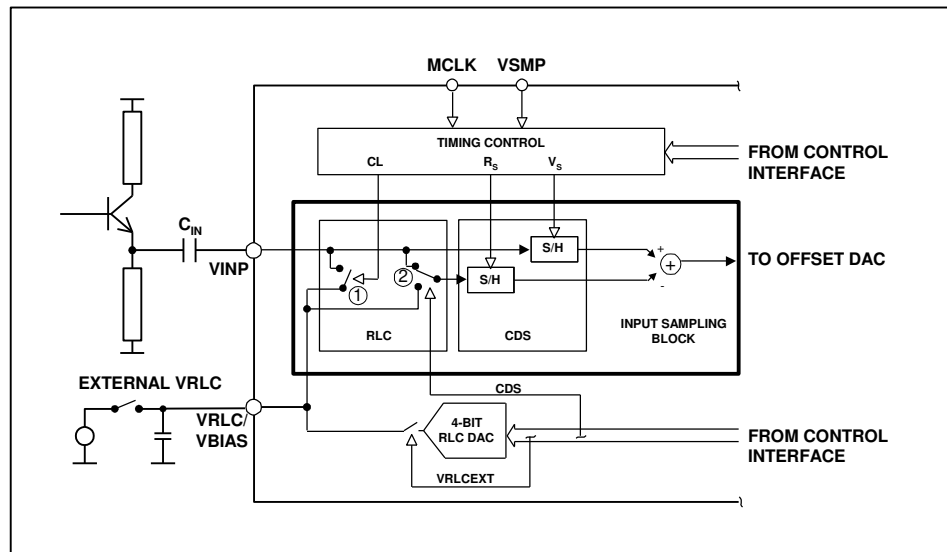

Figure 7 Reset Level Clamping and CDS Circuitry

Reset Level Clamping is controlled by register bit RLCINT. Figure 8 illustrates the effect of the RLCINT bit for a typical CCD waveform, with CL applied during the reset period.

The RLCINT register bit is sampled on the positive edge of MCLK that occurs during each VSMP pulse. The sampled level, high (or low) controls the presence (or absence) of the internal CL pulse on the next reset level. The position of CL can be adjusted by using control bits CDSREF[1:0] (Figure 9).

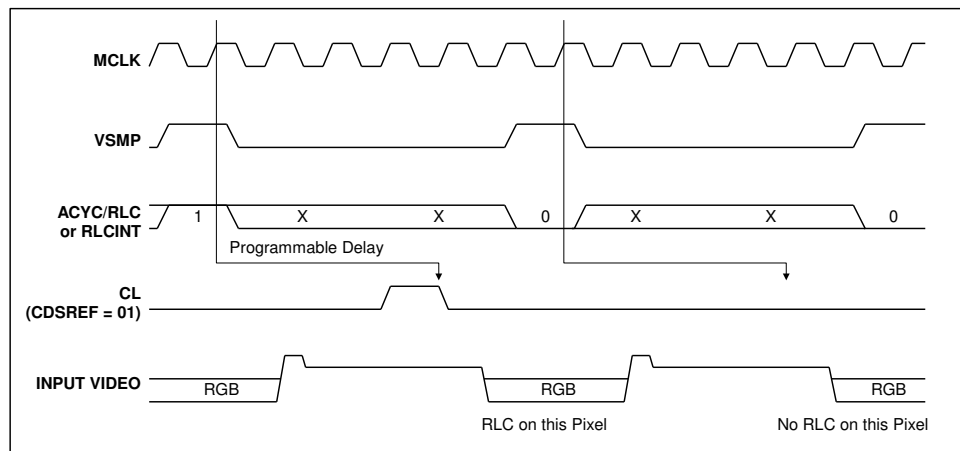

Figure 8 Relationship of RLCINT, MCLK and VSMP to Internal Clamp Pulse, CL

The VRLC/VBIAS pin can be driven internally by a 4-bit DAC (RLCDAC) by writing to control bits RLCV[3:0]. The RLCDAC range and step size may be increased by writing to control bit RLCDACRNG. Alternatively, the VRLC/VBIAS pin can be driven externally by writing to control bit VRLCEXT to disable the RLCDAC and then applying a d.c. voltage to the pin.

CDS/NON-CDS PROCESSING

For CCD type input signals, the signal may be processed using CDS, which will remove pixel-by-pixel common mode noise. For CDS operation, the video level is processed with respect to the video reset level, regardless of whether RLC has been performed. To sample using CDS, control bit CDS must be set to 1 (default), this sets switch 2 into the position shown in (Figure 7) and causes the signal reference to come from the video reset level. The time at which the reset level is sampled, by clock R_s/CL , is adjustable by programming control bits CDSREF[1:0], as shown in Figure 9.

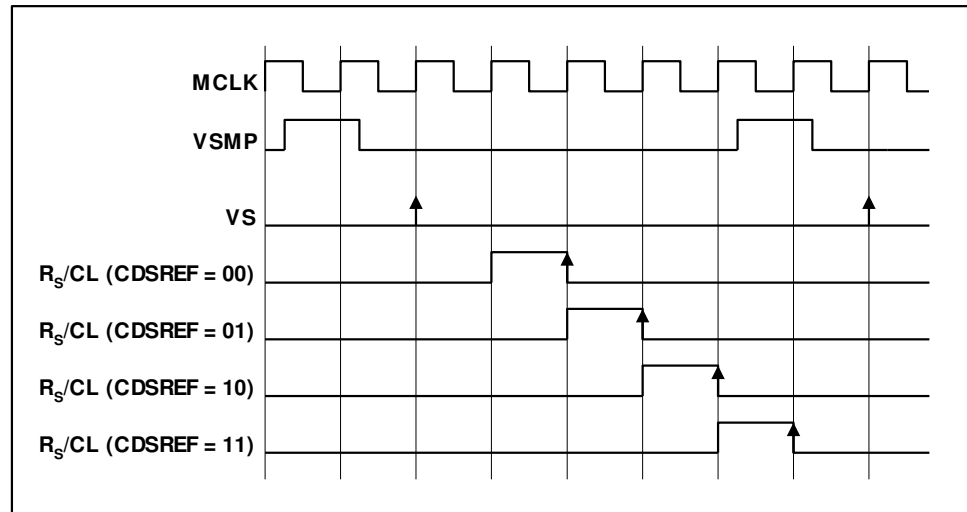

Figure 9 Reset Sample and Clamp Timing

For CIS type sensor signals, non-CDS processing is used. In this case, the video level is processed with respect to the voltage on pin VRLC/VBIAS, generated internally or externally as described above. The VRLC/VBIAS pin is sampled by R_s at the same time as V_s samples the video level in this mode; non-CDS processing is achieved by setting switch 2 in the lower position, CDS = 0.

OFFSET ADJUST AND PROGRAMMABLE GAIN

The output from the CDS block is a differential signal, which is added to the output of an 8-bit Offset DAC to compensate for offsets and then amplified by an 8-bit PGA. The gain and offset can be set for each of three colours by writing to control bits DACx[7:0] and PGAx[7:0] (where x can be R, G or B).

In colour line-by-line mode the gain and offset coefficients that are applied to the PGA and offset DAC can be multiplexed by control of the INTM[1:0] bits as shown in Table 2.

INTM[1:0]	DESCRIPTION
00	Red offset and gain registers are applied to offset DAC and PGA (DACR[7:0] and PGAR[7:0])
01	Green offset and gain registers applied to offset DAC and PGA (DACG[7:0] and PGAG[7:0])
10	Blue offset and gain registers applied to offset DAC and PGA (DACB[7:0] and PGAB[7:0])
11	Reserved.

Table 2 Offset DAC and PGA Register Control

The gain characteristic of the WM8152 PGA is shown in Figure 10. Figure 11 shows the maximum input voltage (at VINP) that can be gained up to match the ADC full-scale input range (2.5V).

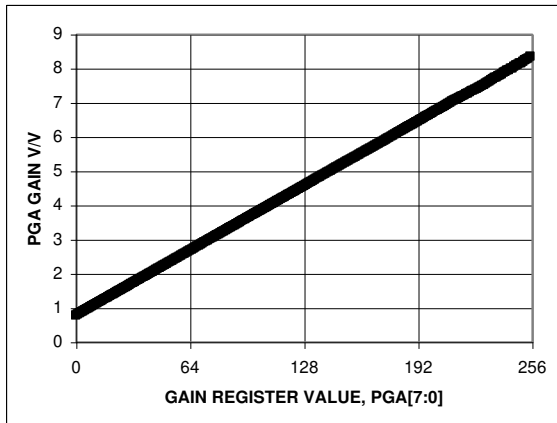
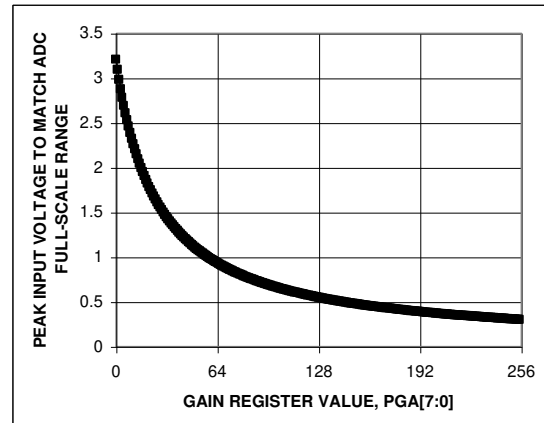
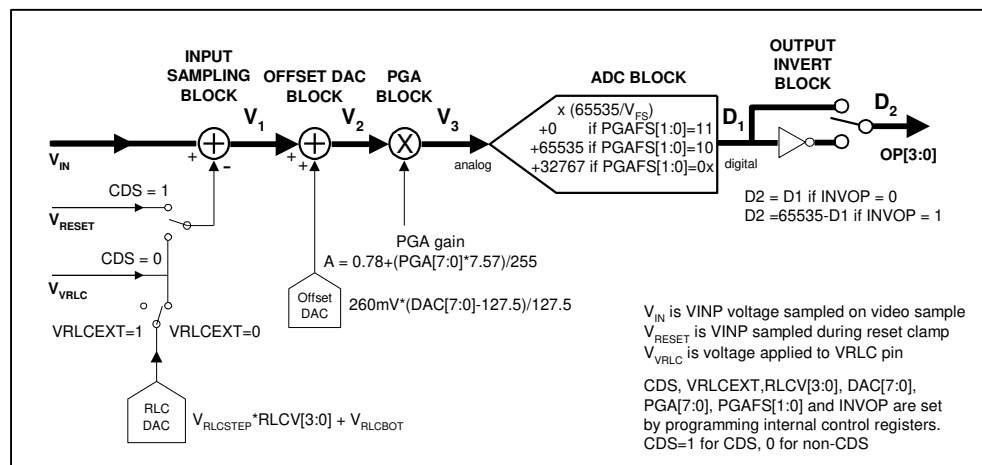

Figure 10 PGA Gain Characteristic

Figure 11 Peak Input Voltage to Match ADC Full-scale Range

ADC INPUT BLOCK LEVEL ADJUST

The output from the PGA should be offset to match the full-scale range of the ADC ($V_{FS} = 2.5V$). For negative-going input video signals, a black level (zero differential) output from the PGA should be offset to the top of the ADC range by setting register bits $PGA_{FS}[1:0]=10$. For positive going input signal the black level should be offset to the bottom of the ADC range by setting $PGA_{FS}[1:0]=11$. Bipolar input video is accommodated by setting $PGA_{FS}[1:0]=00$ or $PGA_{FS}[1:0]=01$ (zero differential input voltage gives mid-range ADC output).

OVERALL SIGNAL FLOW SUMMARY

Figure 12 represents the processing of the video signal through the WM8152.

Figure 12 Overall Signal Flow

The **INPUT SAMPLING BLOCK** produces an effective input voltage V_1 . For CDS, this is the difference between the input video level V_{IN} and the input reset level V_{RESET} . For non-CDS this is the difference between the input video level V_{IN} and the voltage on the VRLC/VBIAS pin, V_{RLC} , optionally set via the RLC DAC.

The **OFFSET DAC BLOCK** then adds the amount of fine offset adjustment required to move the black level of the input signal towards 0V, producing V_2 .

The **PGA BLOCK** then amplifies the white level of the input signal to maximise the ADC range, outputting voltage V_3 .

The **ADC BLOCK** then converts the analogue signal, V_3 , to a 16-bit unsigned digital output, D_1 .

The digital output is then inverted, if required, through the **OUTPUT INVERT BLOCK** to produce D_2 .

CALCULATING OUTPUT FOR ANY GIVEN INPUT

The following equations describe the processing of the video and reset level signals through the WM8152. The values of V_1 , V_2 and V_3 are often calculated in reverse order during device setup. The PGA value is written first to set the input Voltage range, the Offset DAC is then adjusted to compensate for any Black/Reset level offsets and finally the RLC DAC value is set to position the reset level correctly during operation.

Note: Refer to WAN0123 for detailed information on device calibration procedures.

INPUT SAMPLING BLOCK: INPUT SAMPLING AND REFERENCING

If CDS = 1, (i.e. CDS operation) the previously sampled reset level, V_{RESET} , is subtracted from the input video.

$$V_1 = V_{IN} - V_{RESET} \quad \text{Eqn. 1}$$

If CDS = 0, (non-CDS operation) the simultaneously sampled voltage on pin VRLC is subtracted instead.

$$V_1 = V_{IN} - V_{VRLC} \quad \text{Eqn. 2}$$

If VRLCEXT = 1, V_{VRLC} is an externally applied voltage on pin VRLC/VBIAS.

If VRLCEXT = 0, V_{VRLC} is the output from the internal RLC DAC.

$$V_{VRLC} = (V_{RLCSTEP} * RLCV[3:0]) + V_{RLCBOT} \quad \text{Eqn. 3}$$

$V_{RLCSTEP}$ is the step size of the RLC DAC and V_{RLCBOT} is the minimum output of the RLC DAC.

OFFSET DAC BLOCK: OFFSET (BLACK LEVEL) ADJUST

The resultant signal V_1 is added to the Offset DAC output.

$$V_2 = V_1 + \{260\text{mV} * (\text{DAC}[7:0] - 127.5)\} / 127.5 \quad \text{Eqn. 4}$$

PGA NODE: GAIN ADJUST

The signal is then multiplied by the PGA gain,

$$V_3 = V_2 * [0.78 + (\text{PGA}[7:0] * 7.57) / 255] \quad \text{Eqn. 5}$$

ADC BLOCK: ANALOGUE-DIGITAL CONVERSION

The analogue signal is then converted to a 16-bit unsigned number, with input range configured by PGAFS[1:0].

$$D_1[15:0] = \text{INT}\{ (V_3 / V_{FS}) * 65535\} + 32767 \quad \text{PGAFS}[1:0] = 00 \text{ or } 01 \quad \text{Eqn. 6}$$

$$D_1[15:0] = \text{INT}\{ (V_3 / V_{FS}) * 65535\} \quad \text{PGAFS}[1:0] = 11 \quad \text{Eqn. 7}$$

$$D_1[15:0] = \text{INT}\{ (V_3/V_{FS}) * 65535\} + 65535 \quad \text{PGAFS}[1:0] = 10 \quad \text{Eqn. 8}$$

where the ADC full-scale range, $V_{FS} = 2.5V$

$$\begin{aligned} \text{if } D_1[15:0] < 0 & \quad D_1[15:0] = 0 \\ \text{if } D_1[15:0] > 65535 & \quad D_1[15:0] = 65535 \end{aligned}$$

OUTPUT INVERT BLOCK: POLARITY ADJUST

The polarity of the digital output may be inverted by control bit INVOP.

$$D_2[15:0] = D_1[15:0] \quad (\text{INVOP} = 0) \quad \text{Eqn. 9}$$

$$D_2[15:0] = 65535 - D_1[15:0] \quad (\text{INVOP} = 1) \quad \text{Eqn. 10}$$

OUTPUT DATA FORMAT

The digital data output from the ADC is available to the user in 4-bit wide multiplexed. Latency of valid output data with respect to VSMP is programmable by writing to control bits DEL[1:0]. The latency for each mode is shown in the Operating Mode Timing Diagrams section.

Figure 13 shows the output data formats for Mode 1 and 3 – 6. Figure 14 shows the output data formats for Mode 2. Table 3 summarises the output data obtained for each format.

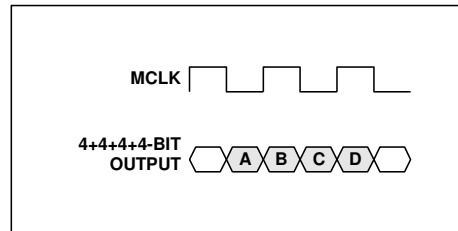

**Figure 13 Output Data Formats
(Modes 1, 3, 4)**

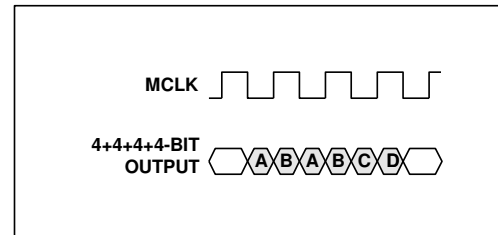

**Figure 14 Output Data Formats
(Mode 2)**

OUTPUT FORMAT	OUTPUT PINS	OUTPUT
4+4+4+4-bit (nibble)	OP[3:0]	A = d15, d14, d13, d12 B = d11, d10, d9, d8 C = d7, d6, d5, d4 D = d3, d2, d1, d0

Table 3 Details of Output Data Shown in Figure 13 and Figure 14

CONTROL INTERFACE

The internal control registers are programmable via the serial digital control interface. The register contents can be read back via the serial interface on pin OP[3]/SDO.

Note: It is recommended that a software reset is carried out after the power-up sequence, before writing to any other register. This ensures that all registers are set to their default values (as shown in Table 5).

SERIAL INTERFACE: REGISTER WRITE

Figure 15 shows register writing in serial mode. Three pins, SCK, SDI and SEN are used. A six-bit address (a5, 0, a3, a2, a1, a0) is clocked in through SDI, MSB first, followed by an eight-bit data word (b7, b6, b5, b4, b3, b2, b1, b0), also MSB first. Each bit is latched on the rising edge of SCK. When the data has been shifted into the device, a pulse is applied to SEN to transfer the data to the appropriate internal register. Note all valid registers have address bit a4 equal to 0 in write mode.

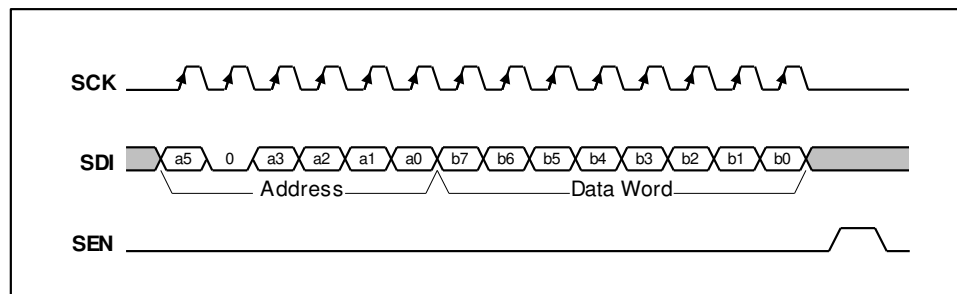

Figure 15 Serial Interface Register Write

A software reset is carried out by writing to Address “000100” with any value of data, (i.e. Data Word = XXXXXXXX).

SERIAL INTERFACE: REGISTER READ-BACK

Figure 16 shows register read-back in serial mode. Read-back is initiated by writing to the serial bus as described above but with address bit a4 set to 1, followed by an 8-bit dummy data word. Writing address (a5, 1, a3, a2, a1, a0) will cause the contents (d7, d6, d5, d4, d3, d2, d1, d0) of corresponding register (a5, 0, a3, a2, a1, a0) to be output MSB first on pin SDO (on the falling edge of SCK). Note that pin SDO is shared with an output pin, OP[3], so no data can be read when reading from a register. The next word may be read in to SDI while the previous word is still being output on SDO.

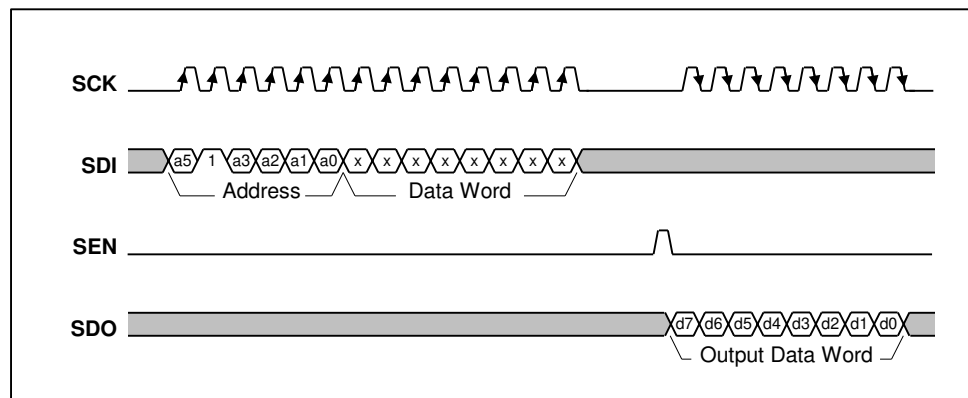

Figure 16 Serial Interface Register Read-back

TIMING REQUIREMENTS

To use this device a master clock (MCLK) of up to 24MHz and a per-pixel synchronisation clock (VSMP) of up to 12MHz are required. These clocks drive a timing control block, which produces internal signals to control the sampling of the video signal. MCLK to VSMP ratios and maximum sample rates for the various modes are shown in Table 4.

PROGRAMMABLE VSMP DETECT CIRCUIT

The VSMP input is used to determine the sampling point and frequency of the WM8152. Under normal operation a pulse of 1 MCLK period should be applied to VSMP at the desired sampling frequency (as shown in the Operating Mode Timing Diagrams) and the input sample will be taken on the first rising MCLK edge after VSMP has gone low. However, in certain applications such a signal may not be readily available. The programmable VSMP detect circuit in the WM8152 allows the sampling point to be derived from any signal of the correct frequency, such as a CCD shift register clock, when applied to the VSMP pin.

When enabled, by setting the VSMPDET control bit, the circuit detects either a rising or falling edge (determined by POSNNEG control bit) on the VSMP input pin and generates an internal VSMP pulse. This pulse can optionally be delayed by a number of MCLK periods, specified by the VDEL[2:0] bits. Figure 17 shows the internal VSMP pulses that can be generated by this circuit for a typical clock input signal. The internal VSMP pulse is then applied to the timing control block in place of the normal VSMP pulse provided from the input pin. The sampling point then occurs on the first rising MCLK edge after this internal VSMP pulse, as shown in the Operating Mode Timing Diagrams.

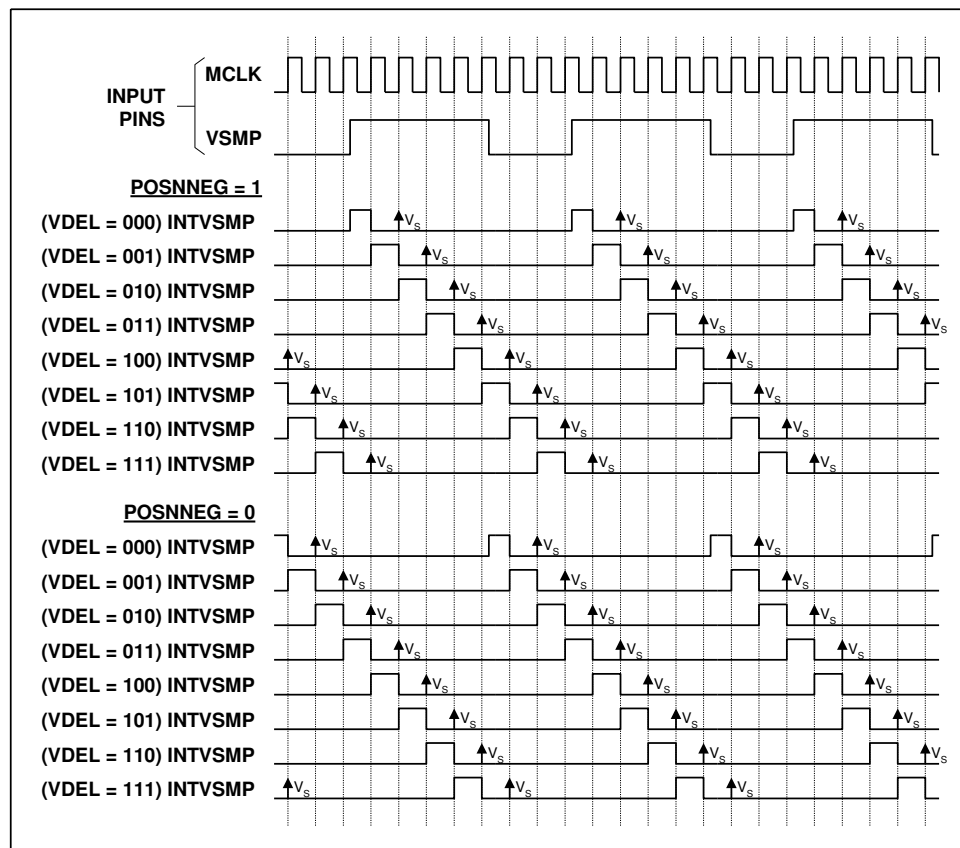

Figure 17 Internal VSMP Pulses Generated by Programmable VSMP Detect Circuit

REFERENCES

The ADC reference voltages are derived from an internal bandgap reference, and buffered to pins VRT and VRB, where they must be decoupled to ground. Pin VRX is driven by a similar buffer, and also requires decoupling. The output buffer from the RLCDAC also requires decoupling at pin VRLC/VBIAS when this is configured as an output.

POWER SUPPLY

The WM8152 can run from a 5V single supply or from split 5V (core) and 3.3V (digital interface) supplies.

POWER MANAGEMENT

Power management for the device is performed via the Control Interface. The device can be powered on or off completely by setting the EN bit low.

All the internal registers maintain their previously programmed value in power down mode and the Control Interface inputs remain active.

OPERATING MODES

Table 4 summarises the most commonly used modes, the clock waveforms required and the register contents required for CDS and non-CDS operation.

MODE	DESCRIPTION	CDS AVAILABLE	MAX SAMPLE RATE	TIMING REQUIREMENTS	REGISTER CONTENTS WITH CDS	REGISTER CONTENTS WITHOUT CDS
1	Monochrome/ Colour Line-by-Line	Yes	4MSPS	MCLK max = 24MHz MCLK:VSMP ratio is 6:1	SetReg1: 0F(hex)	SetReg1: 0D(hex)
2	Fast Monochrome/ Colour Line-by-Line	Yes	8MSPS	MCLK max = 24MHz MCLK:VSMP ratio is 3:1	Identical to Mode 1 plus SetReg3: bits 5:4 must be set to 0(hex)	Identical to Mode 1
3	Maximum speed Monochrome/ Colour Line-by-Line	No	12MSPS	MCLK max = 24MHz MCLK:VSMP ratio is 2:1	CDS not possible	SetReg1: 4D(hex)
4	Slow Monochrome/ Colour Line-by-Line	Yes	3MSPS	MCLK max = 24MHz MCLK:VSMP ratio is 2n:1, n ≥ 4	Identical to Mode 1	Identical to Mode 1

Table 4 WM8152 Operating Modes

OPERATING MODE TIMING DIAGRAMS

The following diagrams show 4-bit multiplexed output data and MCLK, VSMP and input video requirements for operation of the most commonly used modes as shown in Table 4. The diagrams are identical for both CDS and non-CDS operation.

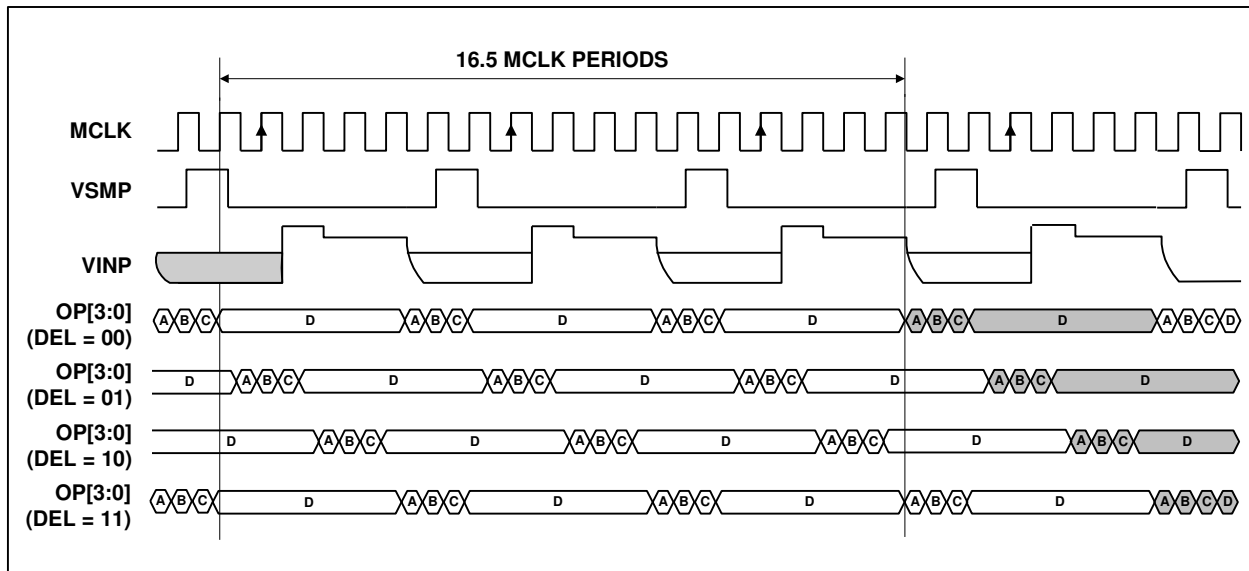
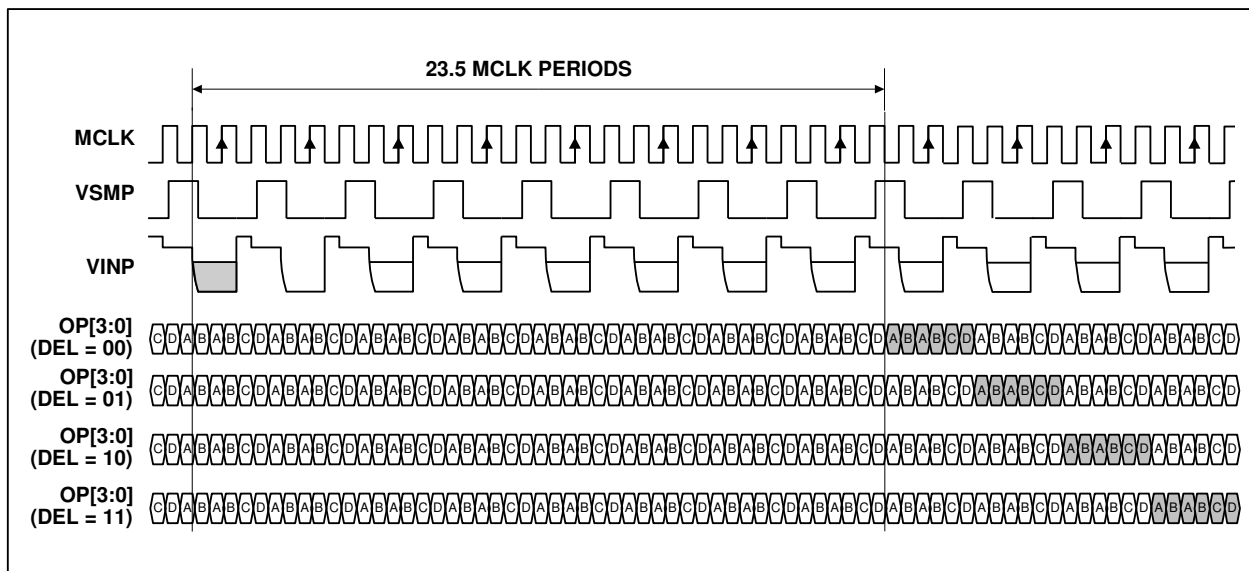
Figure 18 Mode 1 Operation

Figure 19 Mode 2 Operation

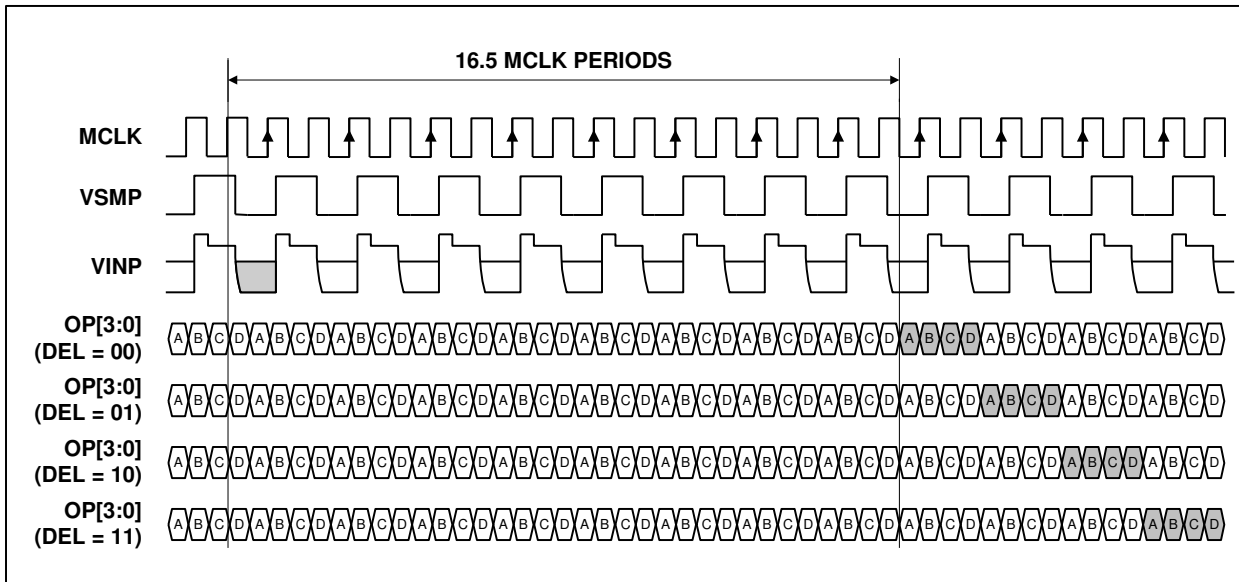

Figure 20 Mode 3 Operation

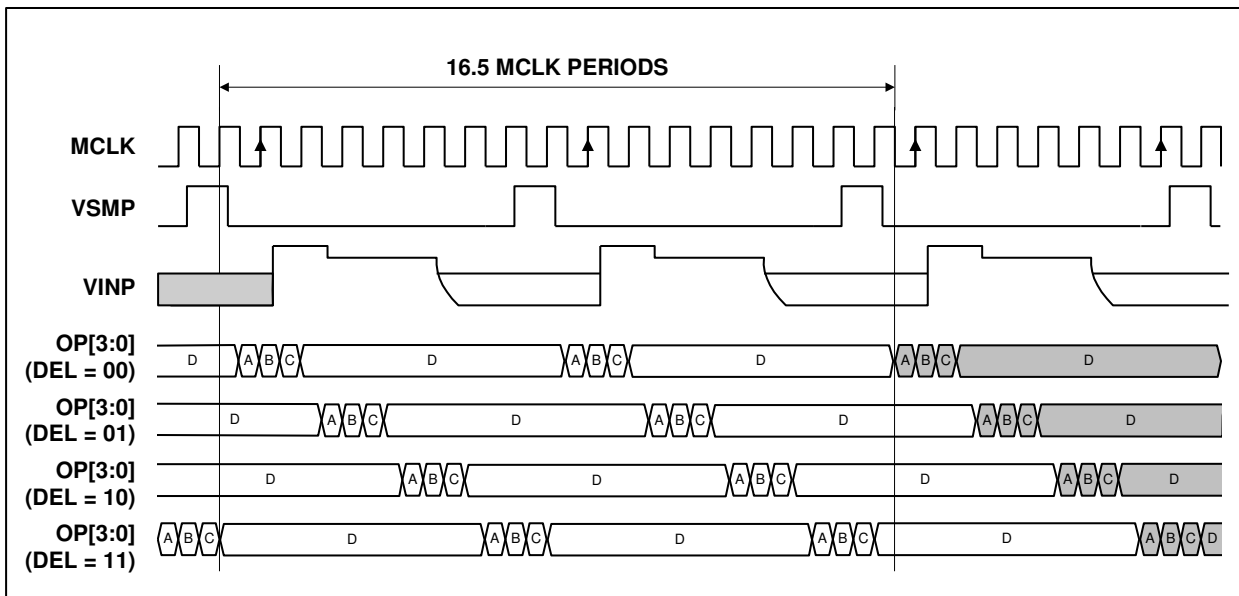

Figure 21 Mode 4 Operation (MCLK:VSMP Ratio = 8:1)

DEVICE CONFIGURATION
REGISTER MAP

The following table describes the location of each control bit used to determine the operation of the WM8152. The register map is programmed by writing the required codes to the appropriate addresses via the serial interface.

ADDRESS <a5:a0>	DESCRIPTION	DEF (hex)	RW	BIT							
				b7	b6	b5	b4	b3	b2	b1	b0
000001	Setup Reg 1	0F	RW	0	MODE3	PGAFS[1]	PGAFS[0]	1	1	CDS	EN
000010	Setup Reg 2	23	RW	DEL[1]	DEL[0]	RLCDACRNG	0	VRLEXEXT	INVOP	1	1
000011	Setup Reg 3	1F	RW	0	0	CDSREF [1]	CDSREF [0]	RLCV[3]	RLCV[2]	RLCV[1]	RLCV[0]
000100	Software Reset	00	W								
000110	Setup Reg 4	05	RW	0	0	INTM[1]	INTM[0]	RLCINT	1	0	1
000111	Revision Number	41	R	0	1	0	0	0	0	0	1
001000	Setup Reg 5	00	RW	0	0	0	POSNNEG	VDEL[2]	VDEL[1]	VDEL[0]	VSMDET
001001	Test Reg 1	00	RW	TCLK	0	0	0	0	0	0	0
001010	Reserved	00	RW	0	0	0	0	0	0	0	0
001011	Reserved	00	RW	0	0	0	0	0	0	0	0
001100	Reserved	00	RW	0	0	0	0	0	0	0	0
100000	DAC Value (Red)	80	RW	DACR[7]	DACR[6]	DACR[5]	DACR[4]	DACR[3]	DACR[2]	DACR[1]	DACR[0]
100001	DAC Value (Green)	80	RW	DACG[7]	DACG[6]	DACG[5]	DACG[4]	DACG[3]	DACG[2]	DACG[1]	DACG[0]
100010	DAC Value (Blue)	80	RW	DACB[7]	DACB[6]	DACB[5]	DACB[4]	DACB[3]	DACB[2]	DACB[1]	DACB[0]
100011	DAC Value (RGB)	80	W	DAC[7]	DAC[6]	DAC[5]	DAC[4]	DAC[3]	DAC[2]	DAC[1]	DAC[0]
101000	PGA Gain (Red)	00	RW	PGAR[7]	PGAR[6]	PGAR[5]	PGAR[4]	PGAR[3]	PGAR[2]	PGAR[1]	PGAR[0]
101001	PGA Gain (Green)	00	RW	PGAG[7]	PGAG[6]	PGAG[5]	PGAG[4]	PGAG[3]	PGAG[2]	PGAG[1]	PGAG[0]
101010	PGA Gain (Blue)	00	RW	PGAB[7]	PGAB[6]	PGAB[5]	PGAB[4]	PGAB[3]	PGAB[2]	PGAB[1]	PGAB[0]
101011	PGA Gain (RGB)	00	W	PGA[7]	PGA[6]	PGA[5]	PGA[4]	PGA[3]	PGA[2]	PGA[1]	PGA[0]

Table 5 Register Map

REGISTER MAP DESCRIPTION

The following table describes the function of each of the control bits shown in Table 5.

REGISTER	BIT NO	BIT NAME(S)	DEFAULT	DESCRIPTION
Setup Register 1	0	EN	1	0 = complete power down, 1 = fully active.
	1	CDS	1	Select correlated double sampling mode: 0 = single ended mode, 1 = CDS mode.
	3:2	Reserved	11	Must be set to one
	5:4	PGAFS[1:0]	00	Offsets PGA output to optimise the ADC range for different polarity sensor output signals. Zero differential PGA input signal gives: 00 = Zero output (use for bipolar video) 10 = Full-scale positive output (use for negative going video) 01 = Zero output (use for positive going video) 11 = Full-scale negative output (use for positive going video)
	6	MODE3	0	Required when operating in MODE3: 0 = other modes, 1 = MODE3.
	7	Reserved	0	Must be set to zero
Setup Register 2	1:0	Reserved	11	Must be set to one
	2	INVOP	0	Digitally inverts the polarity of output data. 0 = negative going video gives negative going output, 1 = negative-going video gives positive going output data.
	3	VRLGEXT	0	When set powers down the RLCDAC, changing its output to Hi-Z, allowing VRLC/VBIAS to be externally driven.
	4	Reserved	0	Must be set to zero
	5	RLCDACRNG	1	Sets the output range of the RLCDAC. 0 = RLCDAC ranges from 0 to VDD (approximately), 1 = RLCDAC ranges from 0 to VRT (approximately).
	7:6	DEL[1:0]	00	Sets the output latency in ADC clock periods. 1 ADC clock period = 2 MCLK periods except in Mode 2 where 1 ADC clock period = 3 MCLK periods. 00 = Minimum latency 10 = Delay by two ADC clock periods 01 = Delay by one ADC clock 11 = Delay by three ADC clock periods period
Setup Register 3	3:0	RLCV[3:0]	1111	Controls RLCDAC driving VRLC pin to define single ended signal reference voltage or Reset Level Clamp voltage. See Electrical Characteristics section for ranges.
	5:4	CDSREF[1:0]	01	CDS mode reset timing adjust. 00 = Advance 1 MCLK period 10 = Retard 1 MCLK period 01 = Normal 11 = Retard 2 MCLK periods
	7:6	Reserved	00	Must be set to zero
Software Reset				Any write to Software Reset causes all cells to be reset. It is recommended that a software reset be performed after a power-up before any other register writes.
Setup Register 4	2:0	Reserved	101	Must be set to 101
	3	RLCINT	0	This bit is used to determine whether Reset Level Clamping is enabled. 0 = RLC disabled, 1 = RLC enabled.
	5:4	INTM[1:0]	00	Colour selection bits used in internal modes. 00 = Red, 01 = Green, 10 = Blue and 11 = Reserved. See Table 2 for details.
	7:6	Reserved	00	Must be set to zero

REGISTER	BIT NO	BIT NAME(S)	DEFAULT	DESCRIPTION		
Setup Register 5	0	VSMPDET	0	0 = Normal operation, signal on VSMP input pin is applied directly to Timing Control block. 1 = Programmable VSMP detect circuit is enabled. An internal synchronisation pulse is generated from signal applied to VSMP input pin and is applied to Timing Control block.		
	3:1	VDEL[2:0]	000	When VSMPDET = 0 these bits have no effect. When VSMPDET = 1 these bits set a programmable delay from the detected edge of the signal applied to the VSMP pin. The internally generated pulse is delayed by VDEL MCLK periods from the detected edge. See Figure 17, Internal VSMP Pulses Generated for details.		
	4	POSNEG	0	When VSMPDET = 0 this bit has no effect. When VSMPDET = 1 this bit controls whether positive or negative edges are detected: 0 = Negative edge on VSMP pin is detected and used to generate internal timing pulse. 1 = Positive edge on VSMP pin is detected and used to generate internal timing pulse. See Figure 17 for further details.		
	7:5	Reserved	000	Must be set to zero		
Test Register 1	7	TCLK	0	0 = Normal Operation, OP[3:0] output ADC data. 1 = Internal Clock Test Mode. This allows internal timing signals to be multiplexed onto the OP[3:0] pins as follows.		
				PIN	TCLK=0	TCLK=1
				OP[3]	OP[3]	INTVSMP
				OP[2]	OP[2]	Video sample clock
				OP[1]	OP[1]	ADC clock
OP[0]	OP[0]	Reset sample clock				
Offset DAC (Red)	7:0	DACR[7:0]	10000000	Red channel offset DAC value. Used under control of the INTM[1:0] control bits.		
Offset DAC (Green)	7:0	DACG[7:0]	10000000	Green channel offset DAC value. Used under control of the INTM[1:0] control bits.		
Offset DAC (Blue)	7:0	DACB[7:0]	10000000	Blue channel offset DAC value. Used under control of the INTM[1:0] control bits.		
Offset DAC (RGB)	7:0	DAC[7:0]		A write to this register location causes the red, green and blue offset DAC registers to be overwritten by the new value		
PGA gain (Red)	7:0	PGAR[7:0]	00000000	Determines the gain of the red channel PGA according to the equation: Red channel PGA gain = $[0.78+(PGAR[7:0]*7.57)/255]$. Used under control of the INTM[1:0] control bits.		
PGA gain (Green)	7:0	PGAG[7:0]	00000000	Determines the gain of the green channel PGA according to the equation: Green channel PGA gain = $[0.78+(PGAG[7:0]*7.57)/255]$. Used under control of the INTM[1:0] control bits.		
PGA gain (Blue)	7:0	PGAB[7:0]	00000000	Determines the gain of the blue channel PGA according to the equation: Blue channel PGA gain = $[0.78+(PGAB[7:0]*7.57)/255]$. Used under control of the INTM[1:0] control bits.		
PGA gain (RGB)	7:0	PGA[7:0]		A write to this register location causes the red, green and blue PGA gain registers to be overwritten by the new value		

Table 6 Register Control Bits

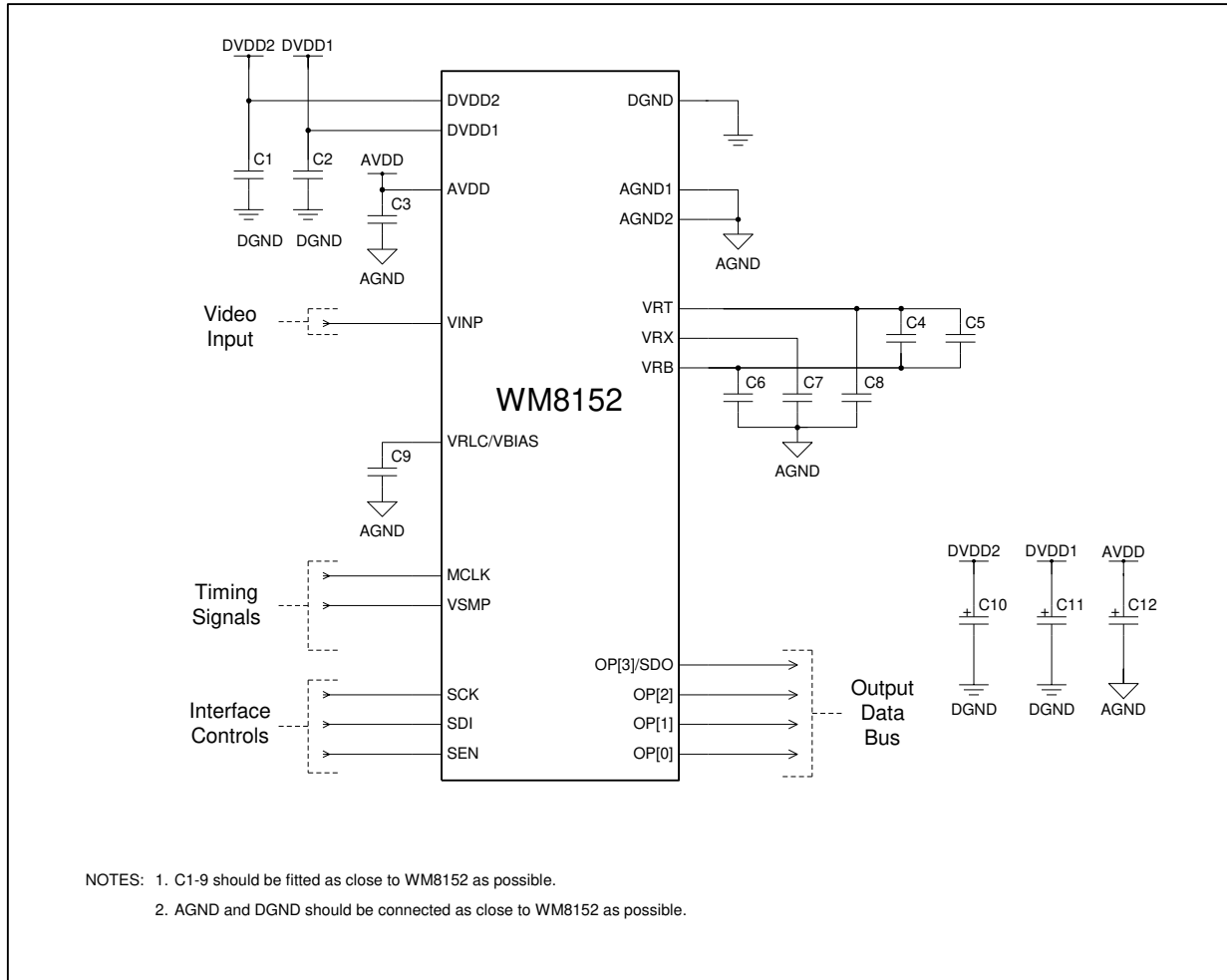
APPLICATIONS INFORMATION
RECOMMENDED EXTERNAL COMPONENTS

Figure 22 External Components Diagram

RECOMMENDED EXTERNAL COMPONENTS VALUES

COMPONENT REFERENCE	SUGGESTED VALUE	DESCRIPTION
C1	100nF	De-coupling for DVDD2.
C2	100nF	De-coupling for DVDD1.
C3	100nF	De-coupling for AVDD.
C4	10nF	High frequency de-coupling between VRT and VRB.
C5	1 μ F	Low frequency de-coupling between VRT and VRB (non-polarised).
C6	100nF	De-coupling for VRB.
C7	100nF	De-coupling for VRX.
C8	100nF	De-coupling for VRT.
C9	100nF	De-coupling for VRLC.
C10	10 μ F	Reservoir capacitor for DVDD2.
C11	10 μ F	Reservoir capacitor for DVDD1.
C12	10 μ F	Reservoir capacitor for AVDD.

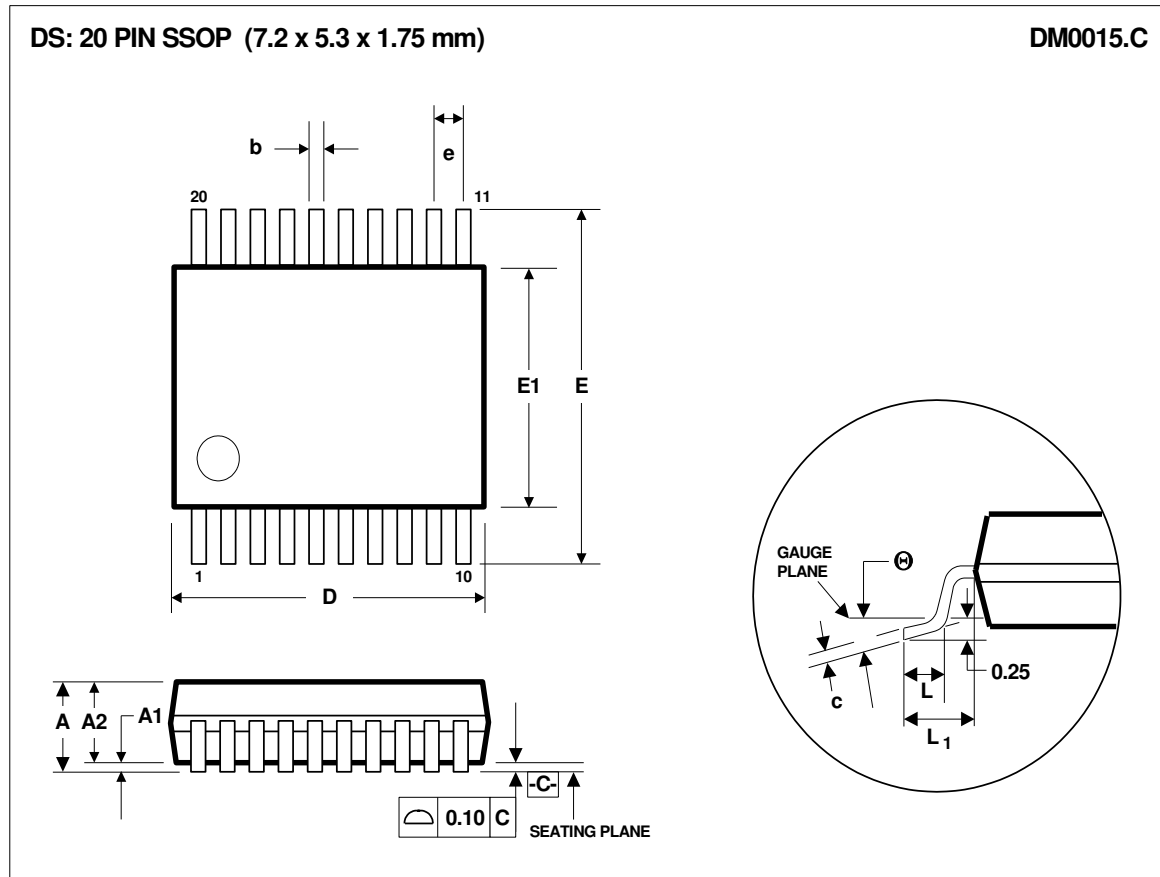
Table 7 External Components Descriptions

PACKAGE DIMENSIONS

Symbols	Dimensions (mm)		
	MIN	NOM	MAX
A	----	----	2.0
A₁	0.05	----	----
A₂	1.65	1.75	1.85
b	0.22	0.30	0.38
c	0.09	----	0.25
D	6.90	7.20	7.50
e	0.65 BSC		
E	7.40	7.80	8.20
E₁	5.00	5.30	5.60
L	0.55	0.75	0.95
L₁	1.25 REF		
θ	0°	4°	8°
REF:	JEDEC.95, MO-150		

NOTES:
 A. ALL LINEAR DIMENSIONS ARE IN MILLIMETERS.
 B. THIS DRAWING IS SUBJECT TO CHANGE WITHOUT NOTICE.
 C. BODY DIMENSIONS DO NOT INCLUDE MOLD FLASH OR PROTRUSION, NOT TO EXCEED 0.20MM.
 D. MEETS JEDEC.95 MO-150, VARIATION = AE. REFER TO THIS SPECIFICATION FOR FURTHER DETAILS.

IMPORTANT NOTICE

Contacting Cirrus Logic Support

For all product questions and inquiries, contact a Cirrus Logic Sales Representative.

To find one nearest you, go to www.cirrus.com.

For the purposes of our terms and conditions of sale, "Preliminary" or "Advanced" datasheets are non-final datasheets that include but are not limited to datasheets marked as "Target", "Advance", "Product Preview", "Preliminary Technical Data" and/or "Pre-production." Products provided with any such datasheet are therefore subject to relevant terms and conditions associated with "Preliminary" or "Advanced" designations. The products and services of Cirrus Logic International (UK) Limited; Cirrus Logic, Inc.; and other companies in the Cirrus Logic group (collectively either "Cirrus Logic" or "Cirrus") are sold subject to Cirrus Logic's terms and conditions of sale supplied at the time of order acknowledgment, including those pertaining to warranty, indemnification, and limitation of liability. Software is provided pursuant to applicable license terms. Cirrus Logic reserves the right to make changes to its products and specifications or to discontinue any product or service. Customers should therefore obtain the latest version of relevant information from Cirrus Logic to verify that the information is current and complete. Testing and other quality control techniques are utilized to the extent Cirrus Logic deems necessary. Specific testing of all parameters of each device is not necessarily performed. In order to minimize risks associated with customer applications, the customer must use adequate design and operating safeguards to minimize inherent or procedural hazards. Cirrus Logic is not liable for applications assistance or customer product design. The customer is solely responsible for its product design, including the specific manner in which it uses Cirrus Logic components, and certain uses or product designs may require an intellectual property license from a third party. Features and operations described herein are for illustrative purposes only and do not constitute a suggestion or instruction to adopt a particular product design or a particular mode of operation for a Cirrus Logic component.

CERTAIN APPLICATIONS USING SEMICONDUCTOR PRODUCTS MAY INVOLVE POTENTIAL RISKS OF DEATH, PERSONAL INJURY, OR SEVERE PROPERTY OR ENVIRONMENTAL DAMAGE ("CRITICAL APPLICATIONS"). CIRRUS LOGIC PRODUCTS ARE NOT DESIGNED, AUTHORIZED OR WARRANTED FOR USE IN PRODUCTS SURGICALLY IMPLANTED INTO THE BODY, AUTOMOTIVE SAFETY OR SECURITY DEVICES, NUCLEAR SYSTEMS, LIFE SUPPORT PRODUCTS OR OTHER CRITICAL APPLICATIONS. INCLUSION OF CIRRUS LOGIC PRODUCTS IN SUCH APPLICATIONS IS UNDERSTOOD TO BE FULLY AT THE CUSTOMER'S RISK AND CIRRUS LOGIC DISCLAIMS AND MAKES NO WARRANTY, EXPRESS, STATUTORY OR IMPLIED, INCLUDING THE IMPLIED WARRANTIES OF MERCHANTABILITY AND FITNESS FOR PARTICULAR PURPOSE, WITH REGARD TO ANY CIRRUS LOGIC PRODUCT THAT IS USED IN SUCH A MANNER. IF THE CUSTOMER OR CUSTOMER'S CUSTOMER USES OR PERMITS THE USE OF CIRRUS LOGIC PRODUCTS IN CRITICAL APPLICATIONS, CUSTOMER AGREES, BY SUCH USE, TO FULLY INDEMNIFY CIRRUS LOGIC, ITS OFFICERS, DIRECTORS, EMPLOYEES, DISTRIBUTORS AND OTHER AGENTS FROM ANY AND ALL LIABILITY, INCLUDING ATTORNEYS' FEES AND COSTS, THAT MAY RESULT FROM OR ARISE IN CONNECTION WITH THESE USES.

This document is the property of Cirrus Logic, and you may not use this document in connection with any legal analysis concerning Cirrus Logic products described herein. No license to any technology or intellectual property right of Cirrus Logic or any third party is granted herein, including but not limited to any patent right, copyright, mask work right, or other intellectual property rights. Any provision or publication of any third party's products or services does not constitute Cirrus Logic's approval, license, warranty or endorsement thereof. Cirrus Logic gives consent for copies to be made of the information contained herein only for use within your organization with respect to Cirrus Logic integrated circuits or other products of Cirrus Logic, and only if the reproduction is without alteration and is accompanied by all associated copyright, proprietary and other notices and conditions (including this notice). This consent does not extend to other copying such as copying for general distribution, advertising or promotional purposes, or for creating any work for resale. This document and its information is provided "AS IS" without warranty of any kind (express or implied). All statutory warranties and conditions are excluded to the fullest extent possible. No responsibility is assumed by Cirrus Logic for the use of information herein, including use of this information as the basis for manufacture or sale of any items, or for infringement of patents or other rights of third parties. Cirrus Logic, Cirrus, the Cirrus Logic logo design, and SoundClear are among the trademarks of Cirrus Logic. Other brand and product names may be trademarks or service marks of their respective owners.

Copyright © 2002–2020 Cirrus Logic, Inc. All rights reserved.

REVISION HISTORY

DATE	REV	DESCRIPTION OF CHANGES	PAGE	CHANGED BY
17/12/03	4.0	Updated to Production Data Front Page, Description, 1 st para – 8MSPS changed to 12MSPS, 2 nd para – words 'during CDS' removed. Table of Contents added Order Codes: leadfree options added + MSL info, p3 Absolute Maximum Ratings: MSL statement updated, p5		JMacD
07/07/04	4.1			AnneS
22/02/07	4.2	Updated rev, copyright and important notice Updated package drawing, p25		CM
27/03/07	4.2	Removed Lead components from ordering information, p3 Added Thermal Performance Table, p5 Added Internal Power on Reset Section, p10 Updated Register Map Descriptions to include Reserved Register bits and to ensure the default column units are consistent , 24/25		JB
06/08/08	4.3	Order Info: /V and /R added to part numbers MSL changed from MSL1 to MSL2, p3		JMacD
16/01/20	4.4	Ordering Information and Absolute Maximum Ratings updated – MSL information removed	3, 5	PH