

REV.	DATE	ECR NO.	DESCRIPTION
NC	02/17/98	-	INITIAL RELEASE
A	05/31/06	-	UPDATE DRAWING FORMAT
B	03/16/09	-	REVISE INTERNAL BODY CONFIGURATION

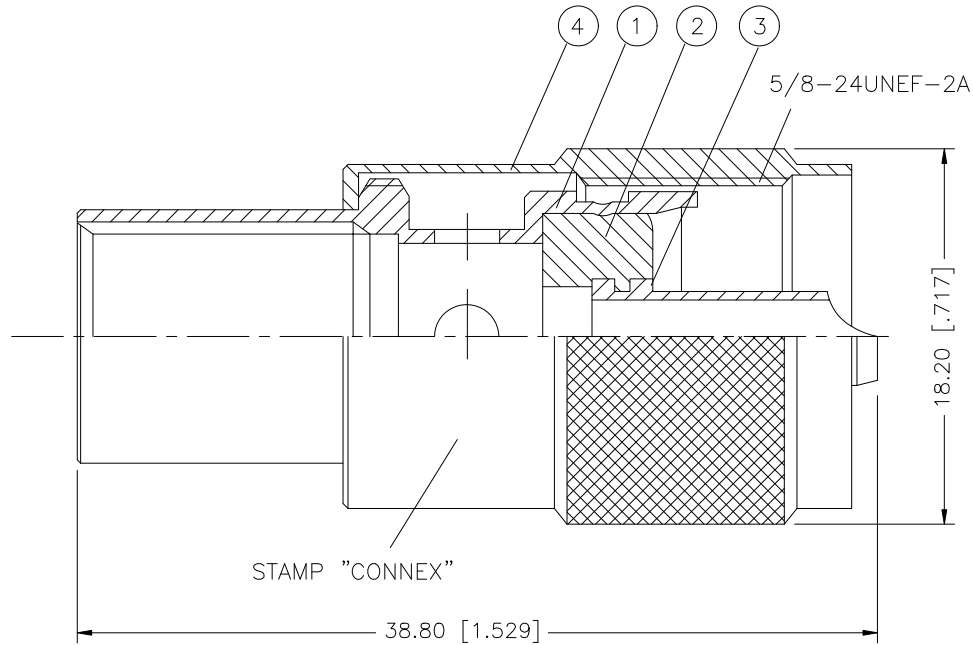

REV.	DATE	ECR NO.	DESCRIPTION
8			
7			
6			
5			
4	COUPLING NUT	BRASS	NICKEL 1
3	CONTACT PIN	BRASS	SILVER 1
2	INSULATOR	PHENOLIC	YELLOW 1
1	BODY	BRASS	NICKEL 1
	DESCRIPTION	MATERIAL	FINISH QTY

UNLESS OTHERWISE SPECIFIED DIMENSIONS ARE IN MILLIMETERS. DIMENSIONS IN [] ARE IN INCHES AND FOR CUSTOMER REFERENCE ONLY.		APPROVALS	DATE	<h1 style="color: blue;">Amphenol Connex</h1> <p>PART DESCRIPTION</p> <p style="text-align: center;">UHF SOLDER PLUG (FOR RG-8/U, 11/U CABLE)</p> <p>PART NO.</p> <p style="text-align: center;">182106</p>							
UNLESS OTHERWISE SPECIFIED TOLERANCES FOR MILLIMETERS ARE: 0.5 - 8mm ± 0.20mm 8 - 30mm ± 0.40mm 30 - 120mm ± 0.50mm		DRAWN	GRS 03/16/09								
UNLESS OTHERWISE SPECIFIED TOLERANCES FOR INCHES ARE: .020 - .315 = ± 0.007" .315 - 1.180 = ± 0.015" 1.180 - 4.724 = ± 0.020"		CHECKED									
DO NOT SCALE DRAWING		ISSUED									
		SHEET	1 OF 1								
		CAD FILE	C:/182/182106.DWG	DWG. NO.	182106.DWG	REV.	NC	SIZE	B	SCALE	NA