

Part Number & Date Code Printing
 PC card drilling dimensions(after plating)
 (thickness 1.60±0.20mm)

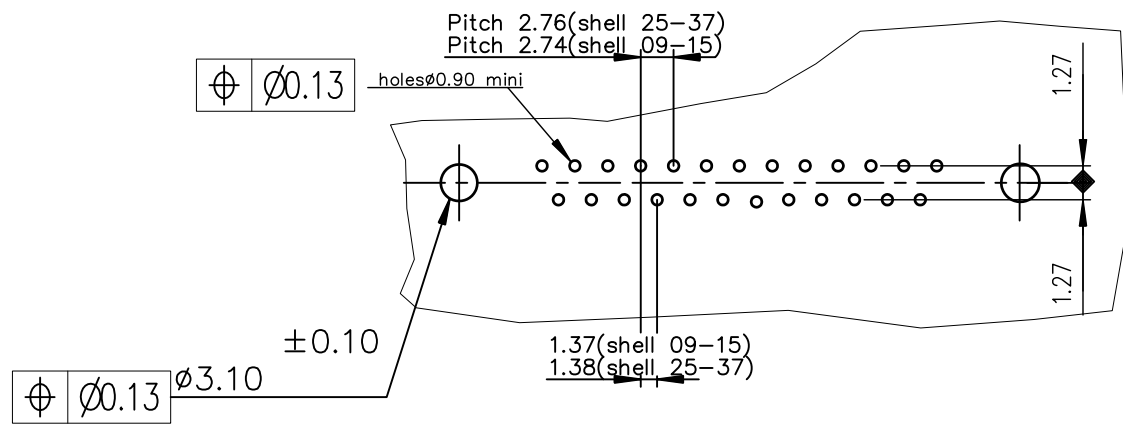

Pull Parts							
SHELL	A±0.38	B±0.12	C±0.10	D±0.25	PART NUMBER	LEAD FREE P/N	
09	30.81	24.99	16.96	16.21	D09S13A*GL00	D09S13A*GL00LF	
15	39.14	33.32	25.18	24.54	D15S13A*GL00	D15S13A*GL00LF	
25	53.03	47.04	39.12	38.25	D25S13A*GL00	D25S13A*GL00LF	
37	69.32	63.50	55.68	54.71	D37S13A*GL00	D37S13A*GL00LF	

4-200 MATING CYCLES
 6-500 MATING CYCLES

GENERAL CHARACTERISTICS : SEE DRAWING C01-8646-0000

mat'l. code SEE.NOTES				surface ISO 1302 ✓		tolerance ISO 406 ISO 1101		projection MM		product family D-SUB	
ltr	ecn no	dr	date	tolerances unless otherwise specified		angles		linear		title	
G	[05-0124	JS	2005/07/27	O.X ±0.1		linear		O.XX ±0.1		SOCKET CONNECT.DELTA D RIGHT ANGLE	
H	[06-0074	SK	2006/06/08	O.XXX ±0.1		0.XX±2°		scale 1:1		WITH NUT,HARPON and metal plate.	
J	ELXI-I-15060	AB	2013/06/25	dr		JOHN.SLEEBA		1994/10/14		dwg no	
K	ELX-I-18948	AB	2014/09/29	enr		ALIAS.BABU		2014/09/29		sheet 1 of 1	
				chr		MITHUN.PAUL		2014/09/29		size 5	
				appd		BIJU.K.PAUL		2014/09/29		A3	
				sheet index						type	
				revision						CUSTOMER Drawing	
				sheet		1					