

Magnetic Sensor series

3-Axis Digital Magnetometer IC

BM1422AGMV

General Description

BM1422AGMV is a 3-axis magnetic sensor which incorporates magneto-impedance (MI) elements to detect magnetic field and a control IC in a small package.

Features

- 3-axis Magnetic Sensor using MI Elements
- I²C Interface
- 12bit / 14bit Digital Output

Applications

- Wristwatch
- Mobile phone, Smartphone

Key Specifications

- Input Voltage Range (AVDD): 1.7V to 3.6V
- Input Voltage Range (DVDD): 1.7V to 3.6V
- Operating Current (100SPS): 0.15mA(Typ)
- Magnetic Measurable Range: ±1200μT(Typ)
- Magnetic Sensitivity: 0.042μT/LSB(Typ)
- Maximum Exposed Field: 1000mT
- Operating Temperature Range: -40°C to +85°C

Package

MLGA010V020A

W(Typ) x D(Typ) x H(Max)

2.00mm x 2.00mm x 1.00mm

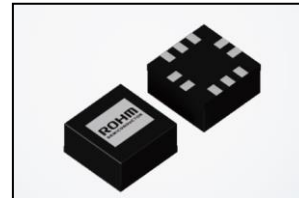

Typical Application Circuit

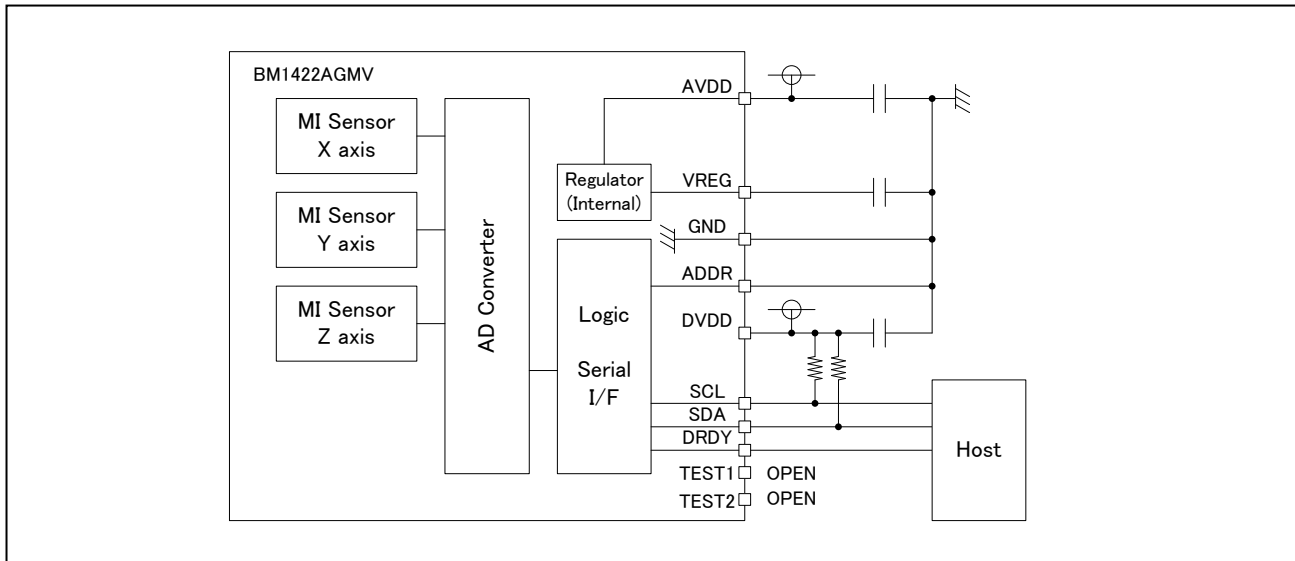

Contents

General Description	1
Features.....	1
Applications	1
Key Specifications.....	1
Package.....	1
Typical Application Circuit	1
Pin Configuration	3
Pin Description.....	3
Block Diagram	4
Absolute Maximum Ratings	5
Thermal Resistance.....	5
Recommended Operating Conditions.....	5
Electrical Characteristics.....	6
Typical Performance Curves.....	7
Figure 1. AVDD PowerDown Current	7
Figure 2. AVDD PowerDown Current	7
Figure 3. DVDD PowerDown Current.....	7
Figure 4. DVDD PowerDown Current.....	7
Figure 5. Average Current during Measurement	8
Figure 6. Measurement Time	8
Figure 7. Output Characteristic	8
I ² C bus Timing Characteristics.....	9
I ² C bus Communication	9
I ² C bus Slave address	10
Register Map	10
Control Sequence	15
Application Example	19
I/O equivalent circuit	20
Operational Notes.....	21
Ordering Information.....	23
Marking Diagrams.....	23
Physical Dimension, Tape and Reel Information.....	24
Revision History.....	25

Pin Configuration

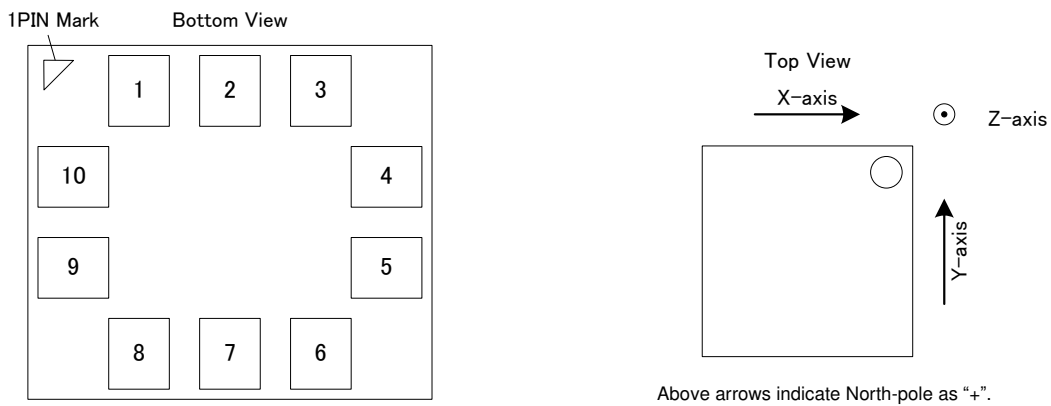

Pin Description

Pin No.	Pin Name	Function
1	AVDD	Analog circuit power supply ^(Note 1)
2	GND	Ground
3	VREG	Internal regulator output ^(Note 2)
4	TEST1	Test pin ^(Note 3)
5	SDA	I ² C signal data I/O
6	TEST2	Test pin ^(Note 3)
7	SCL	I ² C signal clock input
8	DRDY	Data ready output pin
9	ADDR	I ² C programmable address bit ^(Note 4)
10	DVDD	Digital circuit power supply ^(Note 5)

- (Note 1) Please place a bypass capacitor between AVDD and GND in the proximity of the terminals.
- (Note 2) Please place a bypass capacitor between VREG and GND in the proximity of the terminals.
Please set a bypass capacitor of 1.0uF between VREG and GND
- (Note 3) Use as Non-Connection (NC).
- (Note 4) Please connect to DVDD or GND.
- (Note 5) Please place a bypass capacitor between DVDD and GND in the proximity of the terminals.

Block Diagram

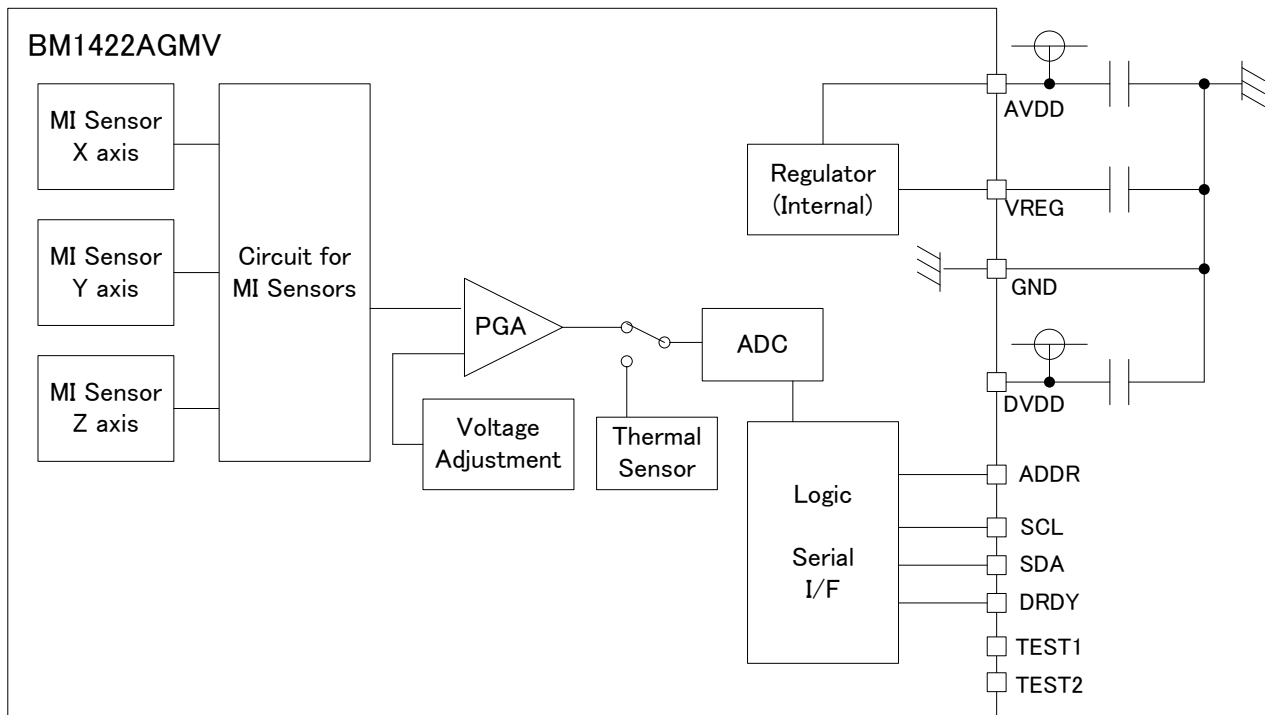

Absolute Maximum Ratings (Ta = 25°C)

Parameter	Symbol	Rating	Unit
Supply Voltage (AVDD)	Vdd_a	4.5	V
Supply Voltage (DVDD)	Vdd_d	4.5	V
Input Voltage	Vin	-0.3 to +(Vdd_d+0.3)	V
Operating Temperature Range	Topr	-40 to +85	°C
Storage Temperature Range	Tstg	-40 to +125	°C
Maximum Exposed Field	Mef	-1000 to +1000	mT

Caution: Operating the IC over the absolute maximum ratings may damage the IC. The damage can either be a short circuit between pins or an open circuit between pins and the internal circuitry. Therefore, it is important to consider circuit protection measures, such as adding a fuse, in case the IC is operated over the absolute maximum ratings.

Thermal Resistance ^(Note 1)

Parameter	Symbol	Thermal Resistance (Typ)		Unit
		1s ^(Note 3)	2s2p ^(Note 4)	
MLGA010V020A				
Junction to Ambient	θ_{JA}	317.3	191.5	°C/W
Junction to Top Characterization Parameter ^(Note 2)	Ψ_{JT}	60	41	°C/W

(Note 1)Based on JESD51-2A(Still-Air)

(Note 2)The thermal characterization parameter to report the difference between junction temperature and the temperature at the top center of the outside surface of the component package.

(Note 3)Using a PCB board based on JESD51-3.

Layer Number of Measurement Board	Material	Board Size
Single	FR-4	114.3mm x 76.2mm x 1.57mmt
Top		
Copper Pattern	Thickness	
Footprints and Traces	70μm	

(Note 4)Using a PCB board based on JESD51-7.

Layer Number of Measurement Board		Material	Board Size		
4 Layers		FR-4	114.3mm x 76.2mm x 1.6mmt		
Top		2 Internal Layers		Bottom	
Copper Pattern	Thickness	Copper Pattern	Thickness	Copper Pattern	Thickness
Footprints and Traces	70μm	74.2mm x 74.2mm	35μm	74.2mm x 74.2mm	70μm

Recommended Operating Conditions (Ta= -40°C to +85°C)

Parameter	Symbol	Rating	Unit
Supply Voltage (AVDD)	Vdd_a	+1.7 to +3.6	V
Supply Voltage (DVDD)	Vdd_d	+1.7 to +3.6	V
I ² C Clock Frequency	fSCL	MAX 400	kHz

Electrical Characteristics (Unless otherwise specified AVDD=1.8V, DVDD=1.8V, GND=0.0V, Ta=25°C)

Parameter	Symbol	Min	Typ	Max	Unit	Conditions
Current Consumption						
Average Current during Measurement	I _{dd}	-	150	300	μA	Output Data Rate = 100SPS
Stand-by-mode Current	I _{ss}	-	1.5	5	μA	ALL Power Down
Logic						
Low-level Input Voltage	V _{IL}	GND	-	0.3 * DVDD	V	
High-level Input Voltage	V _{IH}	0.7 * DVDD	-	DVDD	V	
Low-level Input Current	I _{IL}	-10	-	0	μA	V _{IL} = GND
High-level Input Current	I _{IH}	0	-	10	μA	V _{IH} = DVDD
Low-level Output Voltage	V _{OL}	GND	-	0.2 * DVDD	V	I _L = -0.3mA
High-level Output Voltage	V _{OH}	0.8 * DVDD	-	DVDD	V	I _L = 0.3mA
Serial Communication						
Low-level Input Current	I _{IL2}	-10	-	0	μA	V _{IL} = GND
High-level Input Current	I _{IH2}	0	-	10	μA	At HiZ, V _{IH} = DVDD
Low-level Output Voltage	V _{OL2}	GND	-	0.2 * DVDD	V	I _L = -3mA
Magnetic Sensor						
Moving Range	R _m	-	±300	-	μT	
Measurable Range ^(Note 1)	R _a	-	±1200	-	μT	
X,Y-axis Linearity ^(Note 2)	Lin1	-	0.5	2	%FS	R _m = ±200μT
Z-axis Linearity ^(Note 2)	Lin2	-	1.0	2.8	%FS	R _m = ±200μT
Output Offset	V _{ofs}	-	0	-	LSB	Magnetic Field = 0μT
Magnetic Sensitivity	DeltaV	-	0.042	-	μT/ LSB	
Measurement Time	T _{ms}	-	0.5	-	msec	Average 4times

(Note1) Measurable Range: Overall measurable range within which preset operating range can be fit by adjusting appropriate offsets.

(Note2) Linearity [%FS] = Output Error / R_m = (output – ideal output) / R_m

Typical Performance Curves

(Unless otherwise specified, Ta=25°C, AVDD=1.8V, DVDD=1.8V, GND=0.0V)

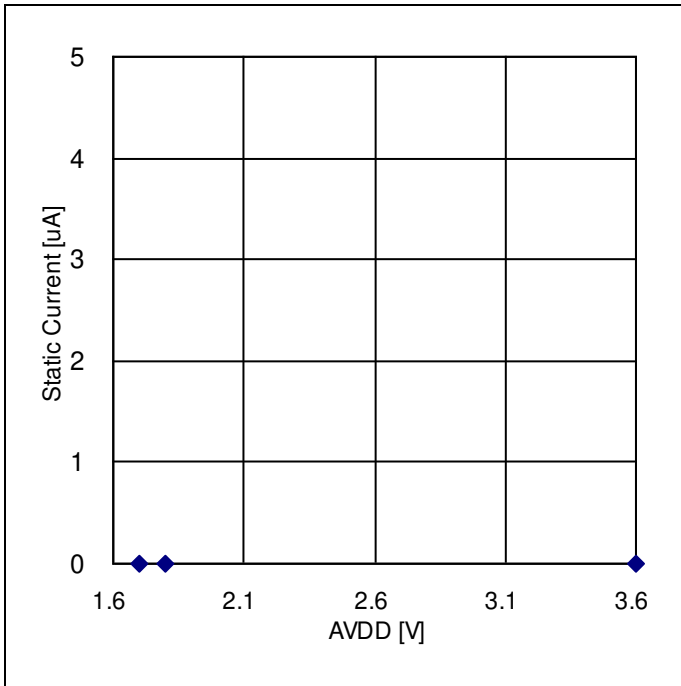

Figure 1. AVDD PowerDown Current Voltage Dependency

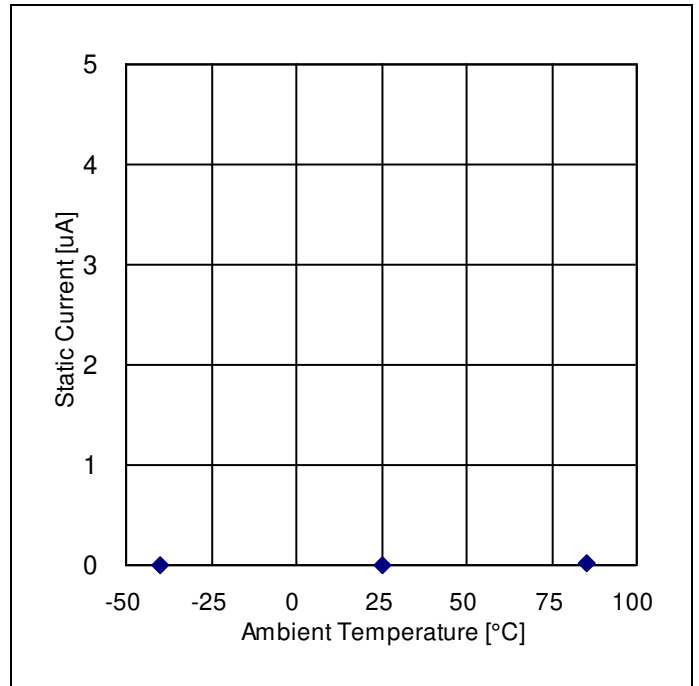

Figure 2. AVDD PowerDown Current Temperature Dependency

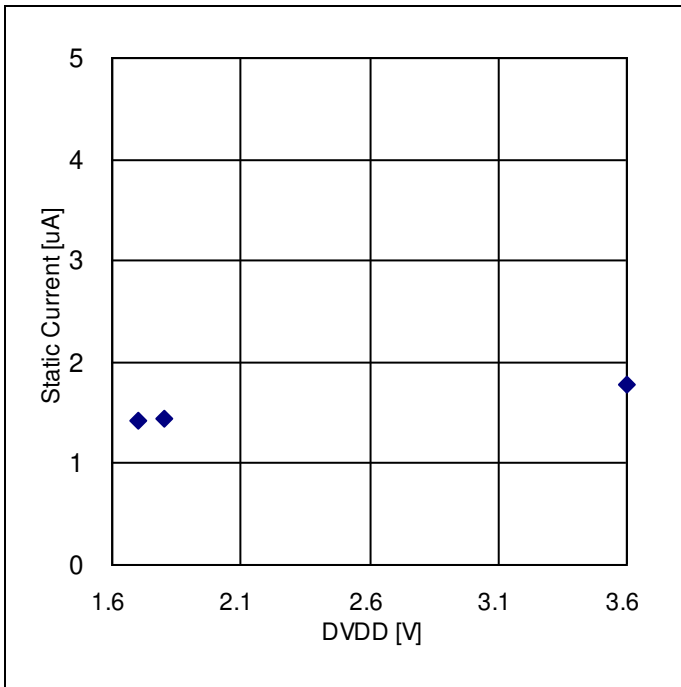

Figure 3. DVDD PowerDown Current Voltage Dependency

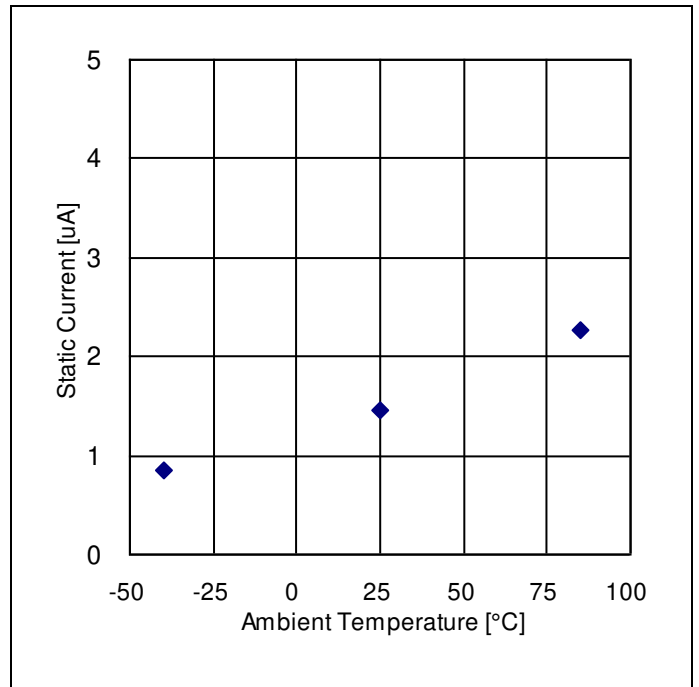

Figure 4. DVDD PowerDown Current Temperature Dependency

Typical Performance Curves - continued

(Unless otherwise specified, Ta=25°C, AVDD=1.8V, DVDD=1.8V, GND=0.0V)

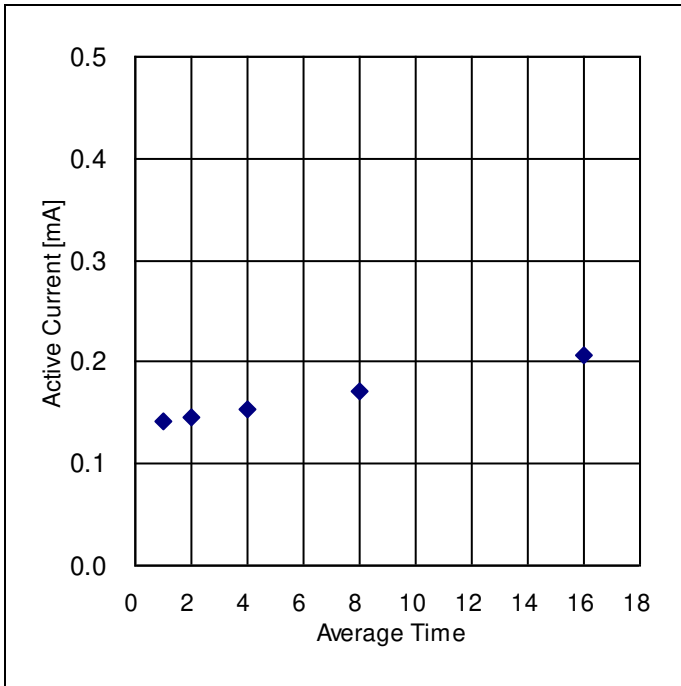

Figure 5. Average Current during Measurement Averaging Dependency (100SPS)

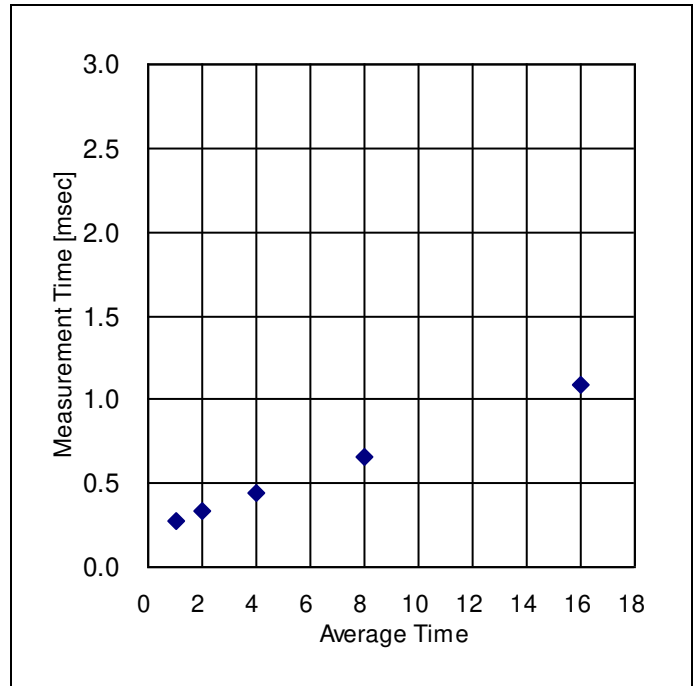

Figure 6. Measurement Time Averaging Dependency

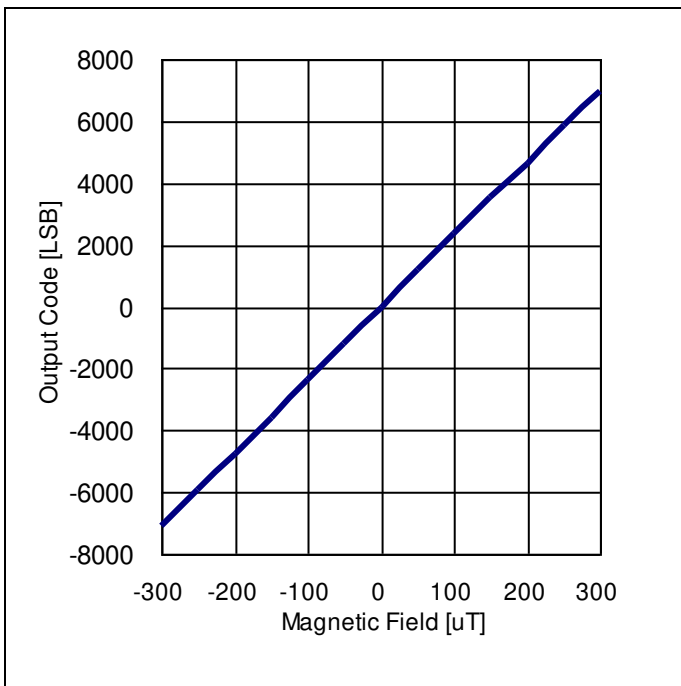
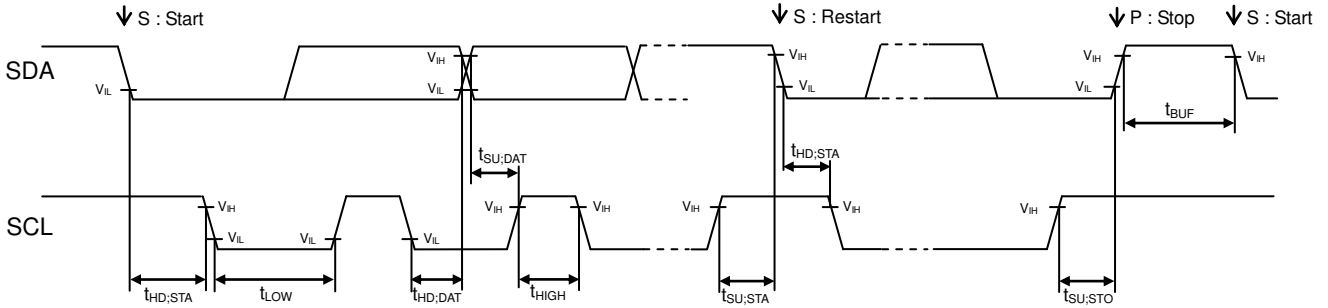

Figure 7. Output Characteristic

I²C bus Timing Characteristics (Unless otherwise specified DVDD =1.8V, Ta = 25°C)



Parameter	Symbol	Min.	Typ.	Max.	Units	Conditions
I ² C SCL Clock frequency	f _{SCL}	0	-	400	kHz	
I ² C 'L' Period of the SCL Clock	t _{LOW}	1.3	-	-	μs	
I ² C 'H' Period of the SCL Clock	t _{HIGH}	0.6	-	-	μs	
I ² C Setup Time for Repeated START Condition	t _{SU:STA}	0.6	-	-	μs	
I ² C Hold Time (Repeated) START Condition	t _{HD:STA}	0.6	-	-	μs	
I ² C Data Setup Time	t _{SU:DAT}	100	-	-	ns	
I ² C Data Hold Time	t _{HD:DAT}	0	-	-	μs	
I ² C Setup Time for STOP Condition	t _{SU:STO}	0.6	-	-	μs	
I ² C Bus Free Time between a STOP and START Condition	t _{BUF}	1.3	-	-	μs	

I²C bus Communication

1. Main write format

(1) Indicate register address



(2) Write to data register after indicating register address

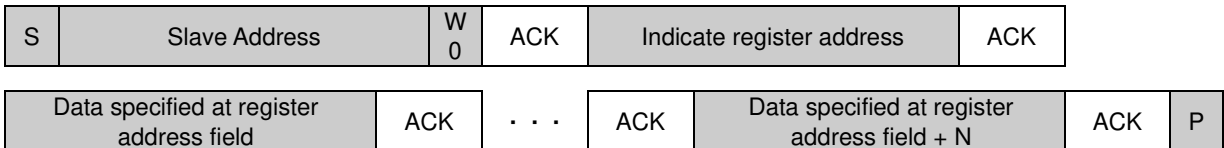

2. Main read format

(1) Read data after indicate register address (Master issues restart condition)

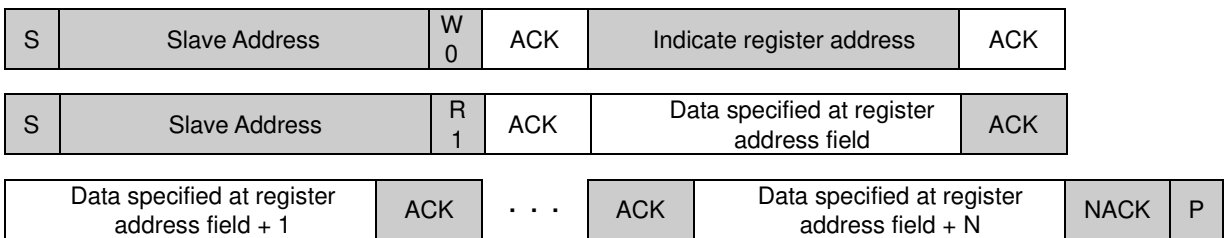

(2) Case of read data

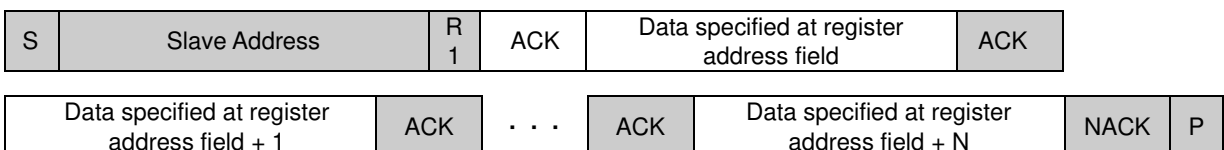

I²C bus Slave addressSelectable I²C Slave Address

(ADDR=L: 0001110, ADDR=H: 0001111)

Register Map ^(Note 1)

Address	Register Name	R/W	D7	D6	D5	D4	D3	D2	D1	D0
0x0D	INFO	R	INFO [7:0]							
0x0E		R	INFO [15:8]							
0x0F	WIA	R	WIA [7:0]							
0x10	DATA_X	R	DATA_X [7:0]							
0x11		R	DATA_X [15:8]							
0x12	DATA_Y	R	DATA_Y [7:0]							
0x13		R	DATA_Y [15:8]							
0x14	DATA_Z	R	DATA_Z [7:0]							
0x15		R	DATA_Z [15:8]							
0x18	STA1	R	0	RD_D RDY	0	0	0	0	0	0
0x1B	CNTL1	RW	PC1	OUT_ BIT	RST_ LV	ODR [1:0]		0	FS1	0
0x1C	CNTL2	RW	0	0	0	0	DREN	DRP	0	0
0x1D	CNTL3	RW	0	FORC E	0	0	0	0	0	0
0x40	AVE_A	RW	0	0	0	AVE_A [2:0]			0	0
0x5C	CNTL4	W	RSTB_LV [7:0]							
0x5D		W	RSTB_LV [15:8]							
0x60	TEMP	R	TEMP [7:0]							
0x61		R	TEMP [15:8]							
0x6C	OFF_X	RW	OFF_X [7:0]							
0x6D		RW	OFF_X [15:8]							
0x72	OFF_Y	RW	OFF_Y [7:0]							
0x73		RW	OFF_Y [15:8]							
0x78	OFF_Z	RW	OFF_Z [7:0]							
0x79		RW	OFF_Z [15:8]							
0x90	FINEOUTPUTX	R	FINEOUTPUTX [7:0]							
0x91		R	FINEOUTPUTX [15:8]							
0x92	FINEOUTPUTY	R	FINEOUTPUTY [7:0]							
0x93		R	FINEOUTPUTY [15:8]							
0x94	FINEOUTPUTZ	R	FINEOUTPUTZ [7:0]							
0x95		R	FINEOUTPUTZ [15:8]							
0x9C	GAIN_PARA_X	R	GAIN_PARA_X [7:0]							
0x9D		R	GAIN_PARA_X [15:8]							
0x9E	GAIN_PARA_Y	R	GAIN_PARA_Y [7:0]							
0x9F		R	GAIN_PARA_Y [15:8]							

0xA0	GAIN_PARA_Z	R	GAIN_PARA_Z [7:0]
0xA1		R	GAIN_PARA_Z [15:8]

(Note 1) Do not write any commands to other addresses except above. Do not write '1' to the fields in which value is '0' in above table.

It is the following conditions to be able to access each register.

Condition	Accessible Register
Supply Power	CNTL1 CNTL4 INFO WIA OFF_X,Y,Z
Supply Power (CNTL1) PC1=1 (CNTL1) RST_LV=0 (CNTL4) RSTB_LV=1	STA1 CNTL2 CNTL3 AVE_A OFF_X,Y,Z
Supply Power (CNTL1) PC1=1 (CNTL1) RST_LV=0 (CNTL4) RSTB_LV=1 (CNTL3) FORCE=1 after first access	DATA_X,Y,Z TEMP FINEOUTPUT_X,Y,Z
Supply Power (CNTL1) PC1=1, FS1=1 (CNTL1) RST_LV=0 (CNTL4) RSTB_LV=1 (CNTL3) FORCE=1 after first access	DATA_X,Y,Z TEMP FINEOUTPUT_X,Y,Z GAIN_PARA_X,Y,Z

(0x0D/0x0E) Information Register

Fields	Function
INFO [7:0]	Information LSB : 0x01
INFO [15:0]	Information MSB : 0x01

(0x0F) WIA Register

Fields	Function
WIA [7:0]	Who I am : 0x41

(0x10/0x11, 0x12/0x13, 0x14/0x15) Output Data Register

Fields	Function
DATAx [7:0]	Xch Output value LSB
DATAx [15:0]	Xch Output value MSB
DATAY [7:0]	Ych Output value LSB
DATAY [15:0]	Ych Output value MSB
DATAz [7:0]	Zch Output value LSB
DATAz [15:0]	Zch Output value MSB

signed 16bit -2048d(0xF800) to +2047d(0x07FF) [Register OUT_BIT=0] default value 0xFFFF
 -8192d(0xE000) to +8191d(0x1FFF) [Register OUT_BIT=1]

(0x18) Status Register

Fields	Function
RD_DRDY	This bit is output to the DRDY to inform the preparation status of the measured data 0 : Not ready NG 1 : Ready OK

default value 0x00

(0x1B) Control setting1 Register

Fields	Function
PC1	Power Control 0 : PowerDown 1 : Active
OUT_BIT	Output Data bit setting 0 : 12bit Output , 1 : 14bit Output
RST_LV	Logic reset control 0 : Reset release 1 : Reset Reset release at RST_LV(CNTL1)=0 & RSTB_LV(CNTL4)=1
ODR [1:0]	Measurement output data rates 00 : 10Hz , 10 : 20Hz , 01 : 100Hz , 11 : 1kHz
FS1	Measurement mode setting 0 : Continuous mode , 1 : Single mode

default value 0x22

(0x1C) Control setting2 Register

Fields	Function
DREN	DRDY terminal enable setting 0 : Disable , 1 : Enable
DRP	DRDY terminal active setting 0 : Low active , 1 : High active

default value 0x04

(0x1D) Control setting3 Register

Fields	Function
FORCE	AD start measurement trigger at continuous mode (FS1=0) and single mode (FS1=1) 1: Start measurement ※Register is automatic clear "0" after write data "1" ※Write data "0" is invalid ※If write data "1" on measurement way, restart measurement

default value 0x00

(0x40) Average time Register

Fields	Function
AVE_A	Average Time 000:4times, 001:1times, 010:2times, 011:8times, 100:16times

default value 0x00

(0x5C/0x5D) Control setting4 Register

Fields	Function
RSTB_LV [7:0]	Reserved (ignore write data)
RSTB_LV [15:8]	RSTB_LV=1 by write access (ignore write data) Reset release at RST_LV(CNTL1)=0 & RSTB_LV(CNTL4)=1 RSTB_LV=0 by write PC1(CNTL1)=0

default value 0x04

(0x60/0x61) Temperature value Register

Fields	Function
TEMP [7:0]	Temperature value LSB
TEMP [15:8]	Temperature value MSB

default value 0xFFFF

unsigned 16bit 0d(0x0000) to +4095d(0x0FFF) [Register OUT_BIT=0]
0d(0x0000) to +16383d(0x3FFF) [Register OUT_BIT=1]

(0x6C/0x6D, 0x72/0x73, 0x78/0x79) Output Data Register

Fields	Function
OFF_X [7:0]	Xch Offset value
OFF_X [15:8]	Reserved Write "00000000"
OFF_Y [7:0]	Ych Offset value
OFF_Y [15:8]	Reserved Write "00000000"
OFF_Z [7:0]	Zch Offset value
OFF_Z [15:8]	Reserved Write "00000000"

default value 0x30

unsigned 8bit 1d(0x01) to +95d(0x5F)

(0x90/0x91, 0x92/0x93, 0x94/0x95) Fine output Register

Fields	Function
FINEOUTPUTX [7:0]	DATA X value per OFF_X LSB
FINEOUTPUTX [15:0]	DATA X value per OFF_X MSB
FINEOUTPUTY [7:0]	DATA Y value per OFF_Y LSB
FINEOUTPUTY [15:0]	DATA Y value per OFF_Y MSB
FINEOUTPUTZ [7:0]	DATA Z value per OFF_Z LSB
FINEOUTPUTZ [15:0]	DATA Z value per OFF_Z MSB

default value 0xFFFF

unsigned 16bit 0d(0x0000) to +16383d(0x3FFF)

(0x9C/0x9D, 0x9E/0x9F, 0xA0/0xA1) Axis interference Register

Fields	Function
GAIN_PARA_X [7:0]	Axis interference Xch to Zch
GAIN_PARA_X [15:0]	Axis interference Xch to Ych
GAIN_PARA_Y [7:0]	Axis interference Ych to Zch
GAIN_PARA_Y [15:0]	Axis interference Ych to Xch
GAIN_PARA_Z [7:0]	Axis interference Zch to Ych
GAIN_PARA_Z [15:0]	Axis interference Zch to Xch

default value 0xXX

unsigned 8bit 0d(0x00) to +255d(0xFF)

Control Sequence

1. Control Sequence

1.1 Power supply start-up sequence

The order of starting up the power supplies of AVDD and DVDD is arbitrary, when they are supplied from different sources. Please do the command control by I²C after all powers are supplied.

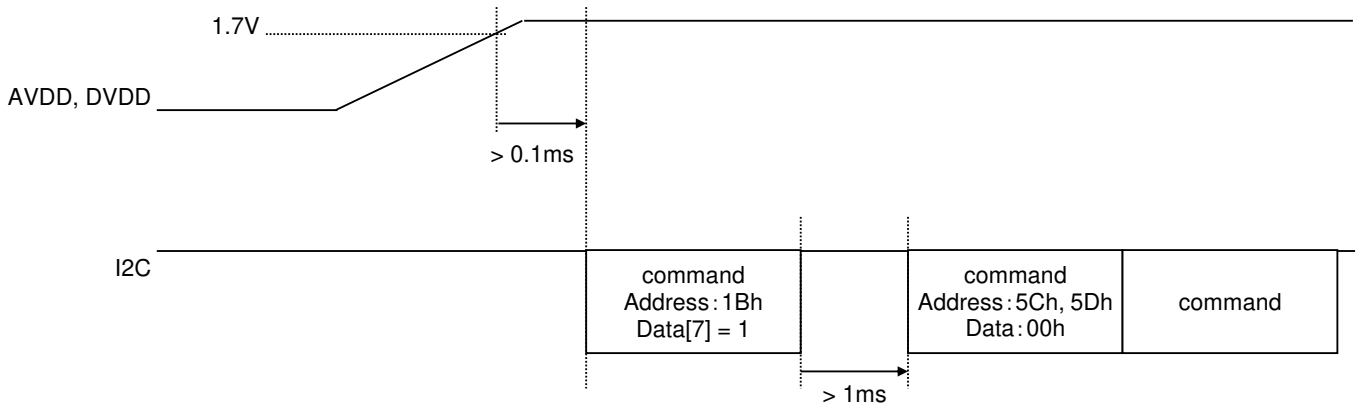

1.2 Power supply end sequence

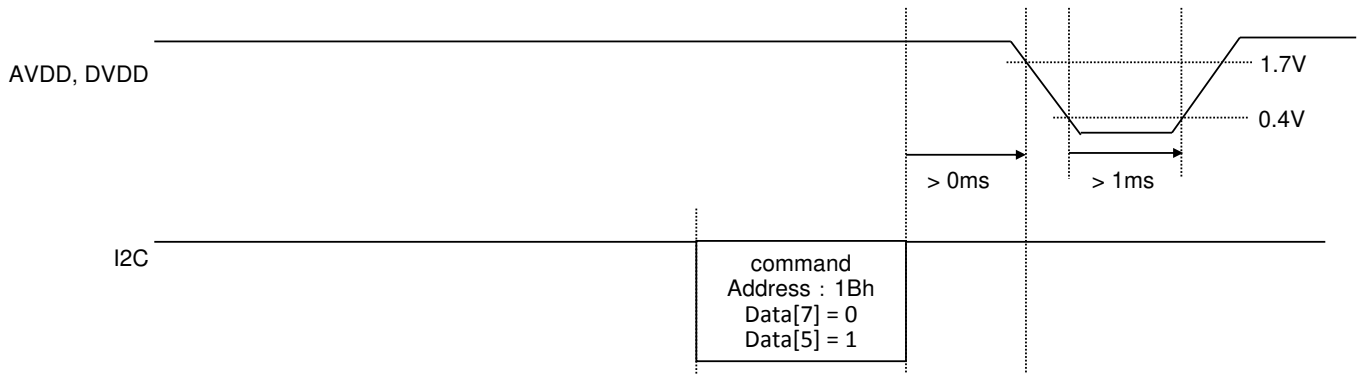

2. Measurement sequence

There are the following two kinds of measurement modes

Continuous Mode	BM1422AGMV is measured at specified cycle (ODR=10,20,100,1kHz) at the cycle.
Single Mode	BM1422AGMV is measured by the measurement request from the host.

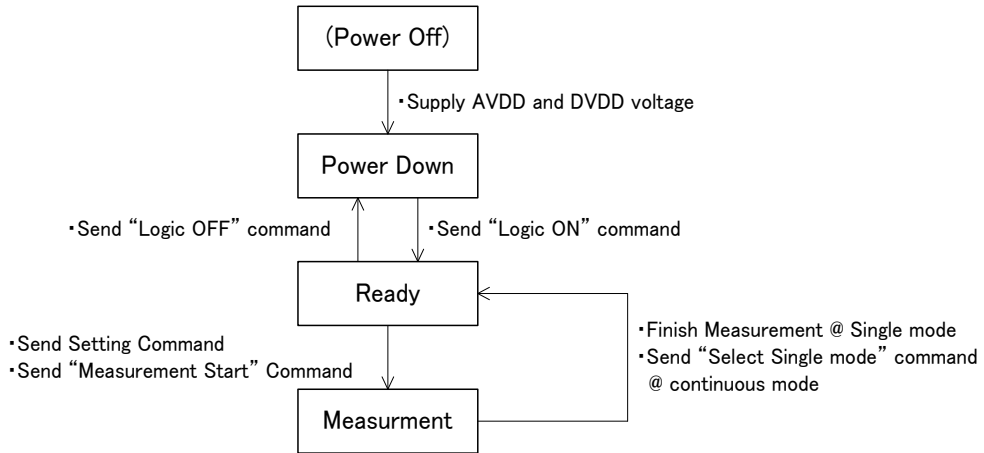

2.1 Continuous Mode

(Send command example) Case of 12bit Output Data

	Register Name	Address	Data
Step1	CNTL1	0x1B	0x80
	CNTL4	0x5C	0x00
Step2	CNTL2	0x1C	0x0C
	OFF_X	0x6C	offx_dat
Step3	OFF_Y	0x72	offy_dat
	OFF_Z	0x78	offz_dat
Step4	CNTL3	0x1D	0x40
Step5	DATAX	0x10	Read
		0x11	
	DATAZ	0x14	Read
		0x15	

(Send command example) Case of 14bit Output Data

	Register Name	Address	Data
Step1	CNTL1	0x1B	0xC0
	CNTL4	0x5C	0x00
Step2	CNTL2	0x1C	0x0C
	OFF_X	0x6C	offx_dat
Step3	OFF_Y	0x72	offy_dat
	OFF_Z	0x78	offz_dat
Step4	CNTL3	0x1D	0x40
Step5	DATAX	0x10	Read
		0x11	
	DATAZ	0x14	Read
		0x15	

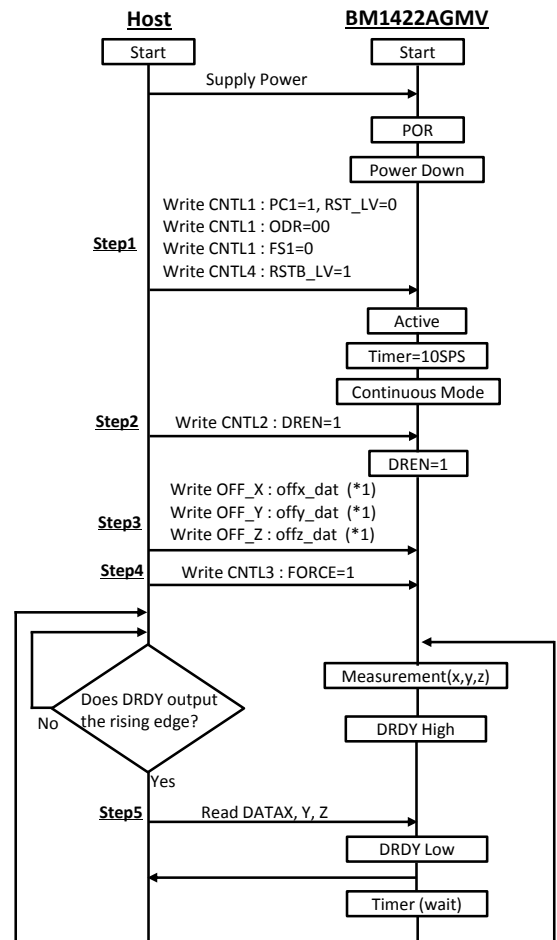

(*1) The value is obtained at offset adjustment. If not obtained yet, then skip.

2.2 Single Mode

(Send command example) Case of 12bit Output Data

	Register Name	Address	Data
Step1	CNTL1	0x1B	0x82
	CNTL4	0x5C 0x5D	0x00
Step2	CNTL2	0x1C	0x0C
Step3	OFF_X	0x6C	offx_dat
	OFF_Y	0x72	offy_dat
	OFF_Z	0x78	offz_dat
Step4	CNTL3	0x1D	0x40
Step5	DATAX	0x10	Read
		0x11	
	DATAY	0x12	
		0x13	
	DATAZ	0x14 0x15	

(Send command example) Case of 14bit Output Data

	Register Name	Address	Data
Step1	CNTL1	0x1B	0xC2
	CNTL4	0x5C 0x5D	0x00
Step2	CNTL2	0x1C	0x0C
Step3	OFF_X	0x6C	offx_dat
	OFF_Y	0x72	offy_dat
	OFF_Z	0x78	offz_dat
Step4	CNTL3	0x1D	0x40
Step5	DATAX	0x10	Read
		0x11	
	DATAY	0x12	
		0x13	
	DATAZ	0x14 0x15	

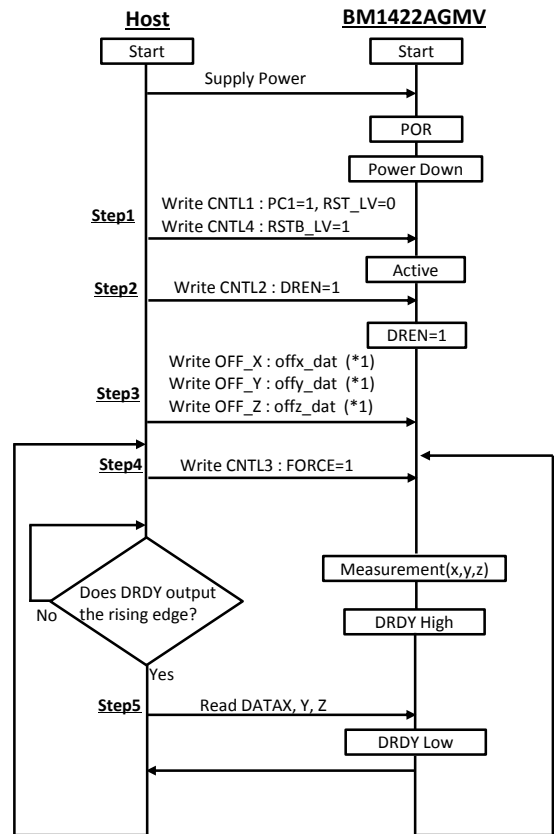

(*1) The value is obtained at offset adjustment. If not obtained yet, then skip.

3. Offset Adjustment

Offset adjustment sequence make the output value around zero under the normal magnetic environment. After measuring the following parameter, HOST should save it in memory, and it needs to be set after applying power supply to BM1422AGMV.

Parameter	Description
offx_dat	Adjusted value of Xch offset
offy_dat	Adjusted value of Ych offset
offz_dat	Adjusted value of Zch offset

(Send command example) Case of 12bit Output Data

	Register Name	Address	Data
Step1	CNTL1	0x1B	0x82
	CNTL4	0x5C	0x00
		0x5D	0x00
Step2	CNTL2	0x1C	0x0C
Step3	OFF_X	0x6C	wk_dat
Step4	CNTL3	0x1D	0x40
Step5	DATA_X	0x10	Read
		0x11	
Step6	OFF_X	0x6C	offx_dat

(Send command example) Case of 14bit Output Data

	Register Name	Address	Data
Step1	CNTL1	0x1B	0xC2
	CNTL4	0x5C	0x00
		0x5D	0x00
Step2	CNTL2	0x1C	0x0C
Step3	OFF_X	0x6C	wk_dat
Step4	CNTL3	0x1D	0x40
Step5	DATA_X	0x10	Read
		0x11	
Step6	OFF_X	0x6C	offx_dat

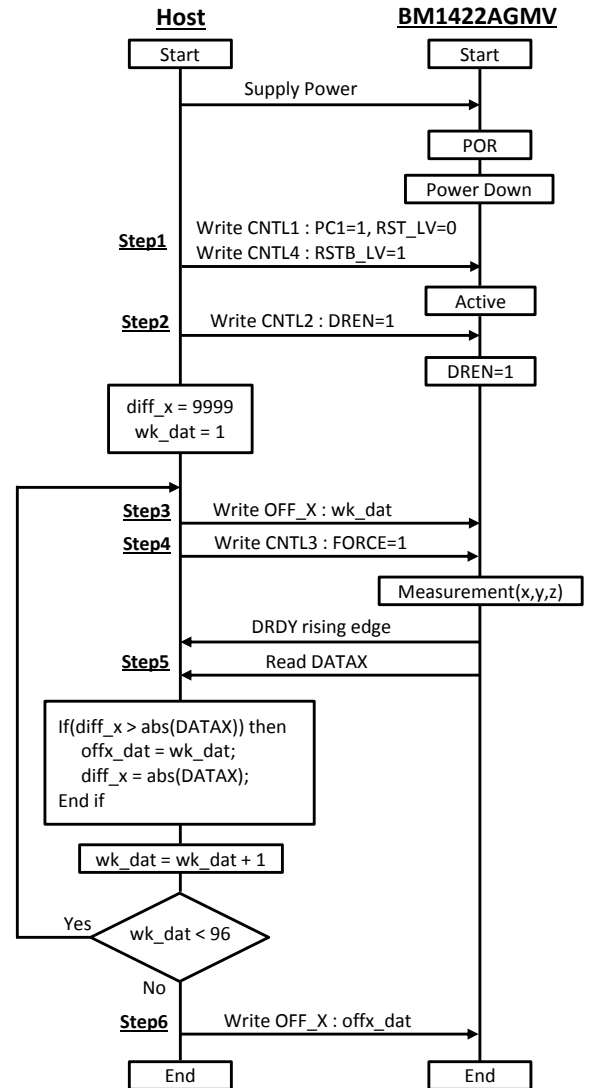

Write only Xch offset adjustment
Ych and Zch should also be performed

When OFF_X, OFF_Y, OFF_Z are changed in the same magnetic field environment, the change directions of the output are as follows

	OFF_X,Y,Z +	OFF_X,Y,Z -
X axis	-	+
Y axis	-	+
Z axis	-	+

Application Example

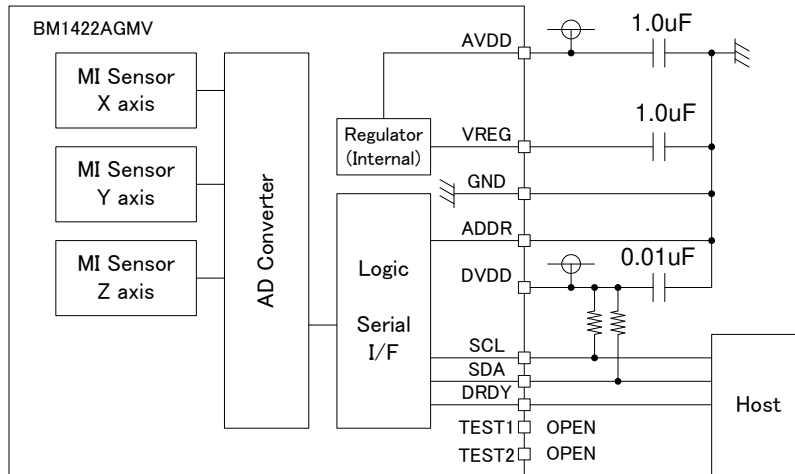

(Note) Sensor property may change due to around magnetic parts. We recommend calibrating the sensitivity and origin point of magnetic sensors after mounting.

I/O equivalent circuit

Pin name	Equivalent Circuit Diagram	Pin name	Equivalent Circuit Diagram
SCL		SDA	
DRDY		ADDR	
TEST1		TEST2	
VREG			

Operational Notes

1. Reverse Connection of Power Supply

Connecting the power supply in reverse polarity can damage the IC. Take precautions against reverse polarity when connecting the power supply, such as mounting an external diode between the power supply and the IC's power supply pins.

2. Power Supply Lines

Design the PCB layout pattern to provide low impedance supply lines. Separate the ground and supply lines of the digital and analog blocks to prevent noise in the ground and supply lines of the digital block from affecting the analog block. Furthermore, connect a capacitor to ground at all power supply pins. Consider the effect of temperature and aging on the capacitance value when using electrolytic capacitors.

3. Ground Voltage

Ensure that no pins are at a voltage below that of the ground pin at any time, even during transient condition.

4. Ground Wiring Pattern

When using both small-signal and large-current ground traces, the two ground traces should be routed separately but connected to a single ground at the reference point of the application board to avoid fluctuations in the small-signal ground caused by large currents. Also ensure that the ground traces of external components do not cause variations on the ground voltage. The ground lines must be as short and thick as possible to reduce line impedance.

5. Thermal Consideration

Should by any chance the power dissipation rating be exceeded the rise in temperature of the chip may result in deterioration of the properties of the chip. In case of exceeding this absolute maximum rating, increase the board size and copper area to prevent exceeding the Pd rating.

6. Recommended Operating Conditions

These conditions represent a range within which the expected characteristics of the IC can be approximately obtained. The electrical characteristics are guaranteed under the conditions of each parameter.

7. Inrush Current

When power is first supplied to the IC, it is possible that the internal logic may be unstable and inrush current may flow instantaneously due to the internal powering sequence and delays, especially if the IC has more than one power supply. Therefore, give special consideration to power coupling capacitance, power wiring, width of ground wiring, and routing of connections.

8. Operation Under Strong Electromagnetic Field

Operating the IC in the presence of a strong electromagnetic field may cause the IC to malfunction.

9. Testing on Application Boards

When testing the IC on an application board, connecting a capacitor directly to a low-impedance output pin may subject the IC to stress. Always discharge capacitors completely after each process or step. The IC's power supply should always be turned off completely before connecting or removing it from the test setup during the inspection process. To prevent damage from static discharge, ground the IC during assembly and use similar precautions during transport and storage.

Operational Notes – continued**10. Inter-pin Short and Mounting Errors**

Ensure that the direction and position are correct when mounting the IC on the PCB. Incorrect mounting may result in damaging the IC. Avoid nearby pins being shorted to each other especially to ground, power supply and output pin. Inter-pin shorts could be due to many reasons such as metal particles, water droplets (in very humid environment) and unintentional solder bridge deposited in between pins during assembly to name a few.

11. Unused Input Pins

Input pins of an IC are often connected to the gate of a MOS transistor. The gate has extremely high impedance and extremely low capacitance. If left unconnected, the electric field from the outside can easily charge it. The small charge acquired in this way is enough to produce a significant effect on the conduction through the transistor and cause unexpected operation of the IC. So unless otherwise specified, unused input pins should be connected to the power supply or ground line.

12. Regarding the Input Pin of the IC

In the construction of this IC, P-N junctions are inevitably formed creating parasitic diodes or transistors. The operation of these parasitic elements can result in mutual interference among circuits, operational faults, or physical damage. Therefore, conditions which cause these parasitic elements to operate, such as applying a voltage to an input pin lower than the ground voltage should be avoided. Furthermore, do not apply a voltage to the input pins when no power supply voltage is applied to the IC. Even if the power supply voltage is applied, make sure that the input pins have voltages within the values specified in the electrical characteristics of this IC.

13. Ceramic Capacitor

When using a ceramic capacitor, determine the dielectric constant considering the change of capacitance with temperature and the decrease in nominal capacitance due to DC bias and others.

14. Absolute Maximum Ratings

Operate the IC such that the output voltage, output current, and power dissipation are all within the Absolute Maximum Ratings.

Ordering Information

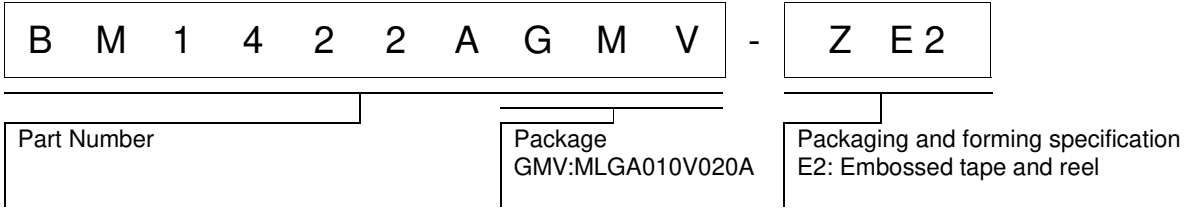

Marking Diagrams

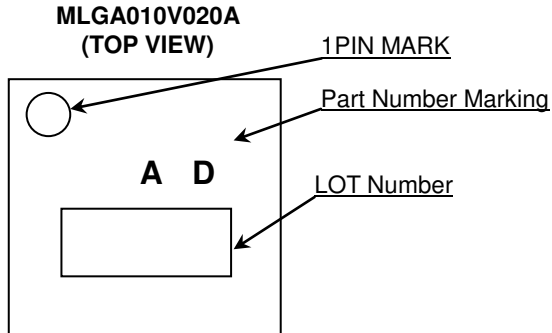

Physical Dimension, Tape and Reel Information

Package Name	MLGA010V020A
--------------	--------------

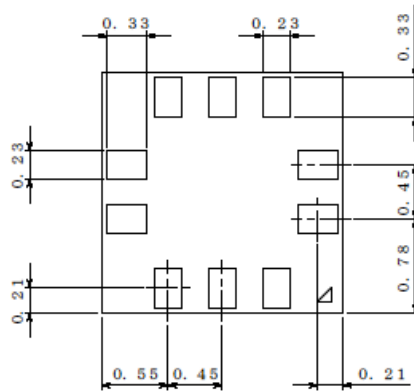
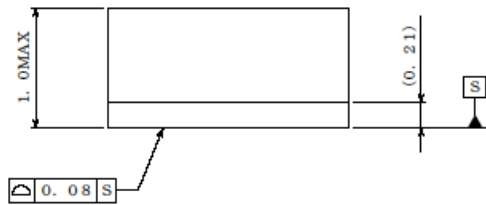
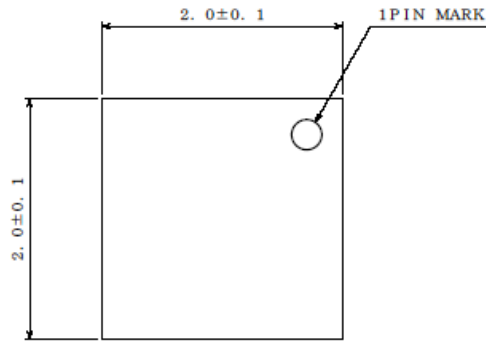

(UNIT : mm)

<Tape and Reel information>

Tape	Embossed carrier tape (with dry pack)
Quantity	2500pcs
Direction of feed	E2 (The direction is the 1pin of product is at the upper left when you hold reel on the left hand and you pull out the tape on the right hand)

* Order quantity needs to be multiple of the minimum quantity.

Revision History

Date	Revision	Changes
17.Oct.2016	001	New Release

Notice

Precaution on using ROHM Products

- Our Products are designed and manufactured for application in ordinary electronic equipments (such as AV equipment, OA equipment, telecommunication equipment, home electronic appliances, amusement equipment, etc.). If you intend to use our Products in devices requiring extremely high reliability (such as medical equipment ^(Note 1), transport equipment, traffic equipment, aircraft/spacecraft, nuclear power controllers, fuel controllers, car equipment including car accessories, safety devices, etc.) and whose malfunction or failure may cause loss of human life, bodily injury or serious damage to property ("Specific Applications"), please consult with the ROHM sales representative in advance. Unless otherwise agreed in writing by ROHM in advance, ROHM shall not be in any way responsible or liable for any damages, expenses or losses incurred by you or third parties arising from the use of any ROHM's Products for Specific Applications.

(Note1) Medical Equipment Classification of the Specific Applications

JAPAN	USA	EU	CHINA
CLASS III	CLASS III	CLASS II b	CLASS III
CLASS IV		CLASS III	

- ROHM designs and manufactures its Products subject to strict quality control system. However, semiconductor products can fail or malfunction at a certain rate. Please be sure to implement, at your own responsibilities, adequate safety measures including but not limited to fail-safe design against the physical injury, damage to any property, which a failure or malfunction of our Products may cause. The following are examples of safety measures:
 - Installation of protection circuits or other protective devices to improve system safety
 - Installation of redundant circuits to reduce the impact of single or multiple circuit failure
- Our Products are designed and manufactured for use under standard conditions and not under any special or extraordinary environments or conditions, as exemplified below. Accordingly, ROHM shall not be in any way responsible or liable for any damages, expenses or losses arising from the use of any ROHM's Products under any special or extraordinary environments or conditions. If you intend to use our Products under any special or extraordinary environments or conditions (as exemplified below), your independent verification and confirmation of product performance, reliability, etc. prior to use, must be necessary:
 - Use of our Products in any types of liquid, including water, oils, chemicals, and organic solvents
 - Use of our Products outdoors or in places where the Products are exposed to direct sunlight or dust
 - Use of our Products in places where the Products are exposed to sea wind or corrosive gases, including Cl₂, H₂S, NH₃, SO₂, and NO₂
 - Use of our Products in places where the Products are exposed to static electricity or electromagnetic waves
 - Use of our Products in proximity to heat-producing components, plastic cords, or other flammable items
 - Sealing or coating our Products with resin or other coating materials
 - Use of our Products without cleaning residue of flux (even if you use no-clean type fluxes, cleaning residue of flux is recommended); or Washing our Products by using water or water-soluble cleaning agents for cleaning residue after soldering
 - Use of the Products in places subject to dew condensation
- The Products are not subject to radiation-proof design.
- Please verify and confirm characteristics of the final or mounted products in using the Products.
- In particular, if a transient load (a large amount of load applied in a short period of time, such as pulse. is applied, confirmation of performance characteristics after on-board mounting is strongly recommended. Avoid applying power exceeding normal rated power; exceeding the power rating under steady-state loading condition may negatively affect product performance and reliability.
- De-rate Power Dissipation depending on ambient temperature. When used in sealed area, confirm that it is the use in the range that does not exceed the maximum junction temperature.
- Confirm that operation temperature is within the specified range described in the product specification.
- ROHM shall not be in any way responsible or liable for failure induced under deviant condition from what is defined in this document.

Precaution for Mounting / Circuit board design

- When a highly active halogenous (chlorine, bromine, etc.) flux is used, the residue of flux may negatively affect product performance and reliability.
- In principle, the reflow soldering method must be used on a surface-mount products, the flow soldering method must be used on a through hole mount products. If the flow soldering method is preferred on a surface-mount products, please consult with the ROHM representative in advance.

For details, please refer to ROHM Mounting specification

Precautions Regarding Application Examples and External Circuits

1. If change is made to the constant of an external circuit, please allow a sufficient margin considering variations of the characteristics of the Products and external components, including transient characteristics, as well as static characteristics.
2. You agree that application notes, reference designs, and associated data and information contained in this document are presented only as guidance for Products use. Therefore, in case you use such information, you are solely responsible for it and you must exercise your own independent verification and judgment in the use of such information contained in this document. ROHM shall not be in any way responsible or liable for any damages, expenses or losses incurred by you or third parties arising from the use of such information.

Precaution for Electrostatic

This Product is electrostatic sensitive product, which may be damaged due to electrostatic discharge. Please take proper caution in your manufacturing process and storage so that voltage exceeding the Products maximum rating will not be applied to Products. Please take special care under dry condition (e.g. Grounding of human body / equipment / solder iron, isolation from charged objects, setting of ionizer, friction prevention and temperature / humidity control).

Precaution for Storage / Transportation

1. Product performance and soldered connections may deteriorate if the Products are stored in the places where:
 - [a] the Products are exposed to sea winds or corrosive gases, including Cl₂, H₂S, NH₃, SO₂, and NO₂
 - [b] the temperature or humidity exceeds those recommended by ROHM
 - [c] the Products are exposed to direct sunshine or condensation
 - [d] the Products are exposed to high Electrostatic
2. Even under ROHM recommended storage condition, solderability of products out of recommended storage time period may be degraded. It is strongly recommended to confirm solderability before using Products of which storage time is exceeding the recommended storage time period.
3. Store / transport cartons in the correct direction, which is indicated on a carton with a symbol. Otherwise bent leads may occur due to excessive stress applied when dropping of a carton.
4. Use Products within the specified time after opening a humidity barrier bag. Baking is required before using Products of which storage time is exceeding the recommended storage time period.

Precaution for Product Label

A two-dimensional barcode printed on ROHM Products label is for ROHM's internal use only.

Precaution for Disposition

When disposing Products please dispose them properly using an authorized industry waste company.

Precaution for Foreign Exchange and Foreign Trade act

Since concerned goods might be fallen under listed items of export control prescribed by Foreign exchange and Foreign trade act, please consult with ROHM in case of export.

Precaution Regarding Intellectual Property Rights

1. All information and data including but not limited to application example contained in this document is for reference only. ROHM does not warrant that foregoing information or data will not infringe any intellectual property rights or any other rights of any third party regarding such information or data.
2. ROHM shall not have any obligations where the claims, actions or demands arising from the combination of the Products with other articles such as components, circuits, systems or external equipment (including software).
3. No license, expressly or implied, is granted hereby under any intellectual property rights or other rights of ROHM or any third parties with respect to the Products or the information contained in this document. Provided, however, that ROHM will not assert its intellectual property rights or other rights against you or your customers to the extent necessary to manufacture or sell products containing the Products, subject to the terms and conditions herein.

Other Precaution

1. This document may not be reprinted or reproduced, in whole or in part, without prior written consent of ROHM.
2. The Products may not be disassembled, converted, modified, reproduced or otherwise changed without prior written consent of ROHM.
3. In no event shall you use in any way whatsoever the Products and the related technical information contained in the Products or this document for any military purposes, including but not limited to, the development of mass-destruction weapons.
4. The proper names of companies or products described in this document are trademarks or registered trademarks of ROHM, its affiliated companies or third parties.

General Precaution

1. Before you use our Products, you are requested to carefully read this document and fully understand its contents. ROHM shall not be in any way responsible or liable for failure, malfunction or accident arising from the use of any ROHM's Products against warning, caution or note contained in this document.
2. All information contained in this document is current as of the issuing date and subject to change without any prior notice. Before purchasing or using ROHM's Products, please confirm the latest information with a ROHM sales representative.
3. The information contained in this document is provided on an "as is" basis and ROHM does not warrant that all information contained in this document is accurate and/or error-free. ROHM shall not be in any way responsible or liable for any damages, expenses or losses incurred by you or third parties resulting from inaccuracy or errors of or concerning such information.