

番号 NO.	名称 NAME	材料 MATERIAL
①	ハウジング HOUSING	液晶ポリマー (LCP) UL94V-0 LIQUID CRYSTAL POLYMER (LCP) UL94V-0
②	カムスライダ CAM SLIDER	液晶ポリマー (LCP) UL94V-0 LIQUID CRYSTAL POLYMER (LCP) UL94V-0
③	ターミナル TERMINAL	銅合金 接触部: 金めっき 0.5µm MIN. (t=0.2) 封孔処理済 テール部: 錫めっき 2µm MIN. 下地: ニッケルめっき 1µm MIN. COPPER ALLOY, CONTACT AREA: Au(0.5µm MIN.) SEALING DISPOSITION TAIL AREA: Sn (2µm MIN.) UNDER: Ni(1µm MIN.)
④	シェル SHELL	ステンレス鋼 基板実装部: 金めっき0.02µm MIN. (t=0.15) 下地: ニッケルめっき0.5µm MIN. STAINLESS STEEL, NAIL AREA: (0.02µm MIN.), UNDER: Ni(0.5µm MIN.)
⑤	スプリング SPRING	ピアノ線 SWP
⑥	ピン PIN	ステンレス鋼 STAINLESS STEEL
⑦	ディテクト レバー DETECT LEVER	銅合金 接触部、テール部: 金めっき 0.2µm MIN. (t=0.15) 下地: ニッケルめっき 1µm MIN. COPPER ALLOY, CONTACT, TAIL AREA: Au(0.2µm MIN.) UNDER: Ni(1µm MIN.)
⑧	ディテクト スイッチ DETECT SWITCH	銅合金 接触部、テール部: 金めっき 0.2µm MIN. (t=0.15) 下地: ニッケルめっき 1µm MIN. COPPER ALLOY, CONTACT, TAIL AREA: Au(0.2µm MIN.) UNDER: Ni(1µm MIN.)

NOTES 1. ターミナル及びネイルの平坦度は0.1 MAX.
TERMINAL AND NAIL COPLANARITY TO BE 0.1 MAX.
△ スタンドオフ寸法 STAND OFF

△ パターン禁止エリア PATTERN PROHIBITION AREA	カード挿入時 CARD INSERTING POSITION	クローズ CLOSE
4. カード検知スイッチ DETECT SWITCH	カード未挿入時 NO CARD	オープン OPEN

5. 肉抜き位置は任意とする。CAVITY IS TO BE OPTIONAL.
6. ロット印字は任意とする。LOT NUMBERING IS TO BE OPTIONAL.
△ GND 推奨パターン GND RECOMMENDED PATTERN.
8. ELV 及び RoHS 適合品 ELV AND RoHS COMPLIANT

502570-0893	502570-0831	502570-08**
EMBOSSED TAPE	CONNECTOR ONLY	MODEL NO.
ORDER No. オーダー番号	MATERIAL NO.	

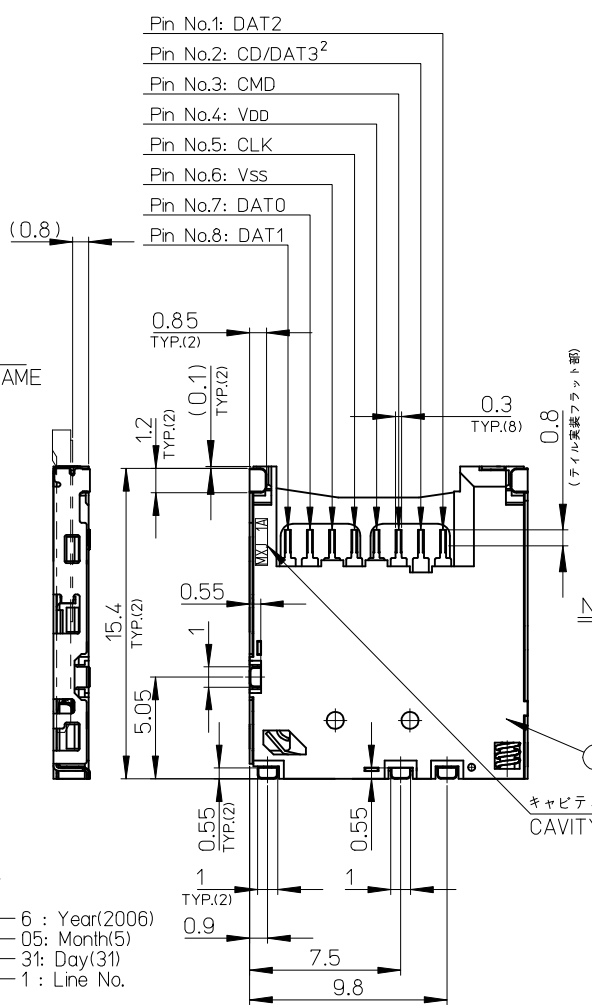
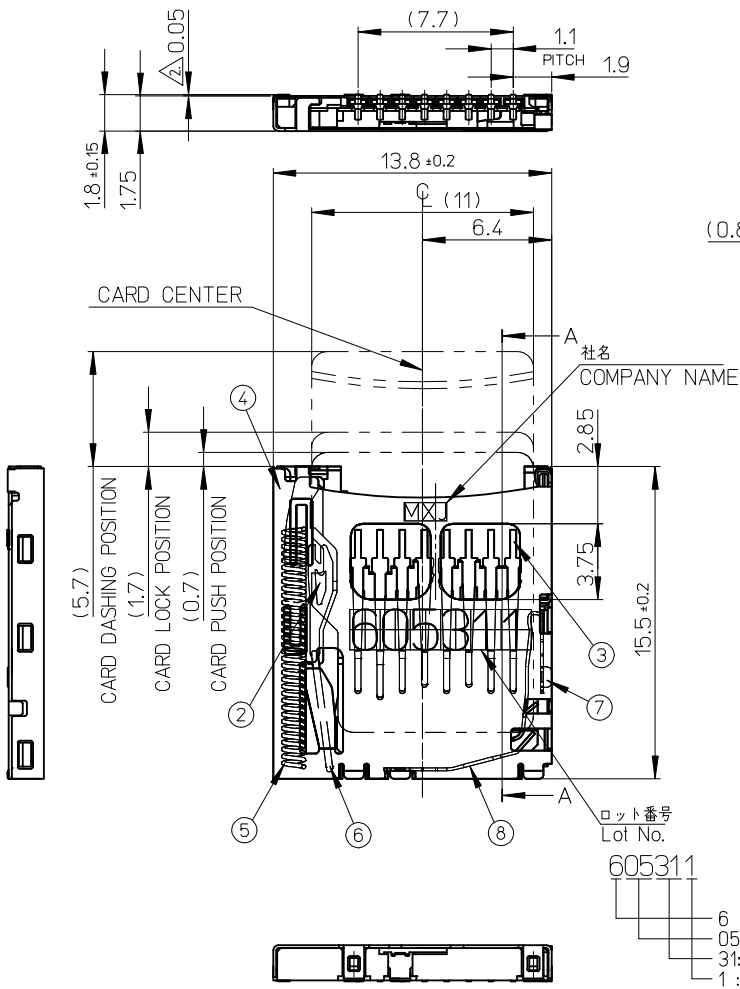

- Pin No.1: DAT2
- Pin No.2: CD/DAT3²
- Pin No.3: CMD
- Pin No.4: VDD
- Pin No.5: CLK
- Pin No.6: VSS
- Pin No.7: DAT0
- Pin No.8: DAT1

ロット番号
Lot No.
605311
6 : Year(2006)
05: Month(5)
31: Day(31)
1 : Line No.

REVISED EC NO: J2009-2308 DRWN: CARIZONO 2009/04/17 CHKD: T. HARIYAMA 2009/04/17 APPR: NUKITA 2009/04/20	GENERAL TOLERANCES (UNLESS SPECIFIED)		DIMENSION STYLE MM ONLY		SCALE 4:1	DESIGN UNITS METRIC	THIRD ANGLE PROJECTION
	10 UNDER	±0.2	DRAWN BY YMATSUMOTO	DATE 07/09/10	TITLE MICROSD CARD CONN. (P/P & NORMALSMALL TYPE)		
	10 OVER 30 UNDER	±0.25	CHECKED BY MTOMITA	DATE 07/09/10	MATERIAL NO. SEE TABLE		
	30 OVER	±0.3	APPROVED BY MSASAO	DATE 07/09/10	DOCUMENT NO. SD-502570-001		
ANGULAR ±1 °	DRAFT WHERE APPLICABLE MUST REMAIN WITHIN DIMENSIONS		SIZE A3		SHEET NO. 1 OF 2		

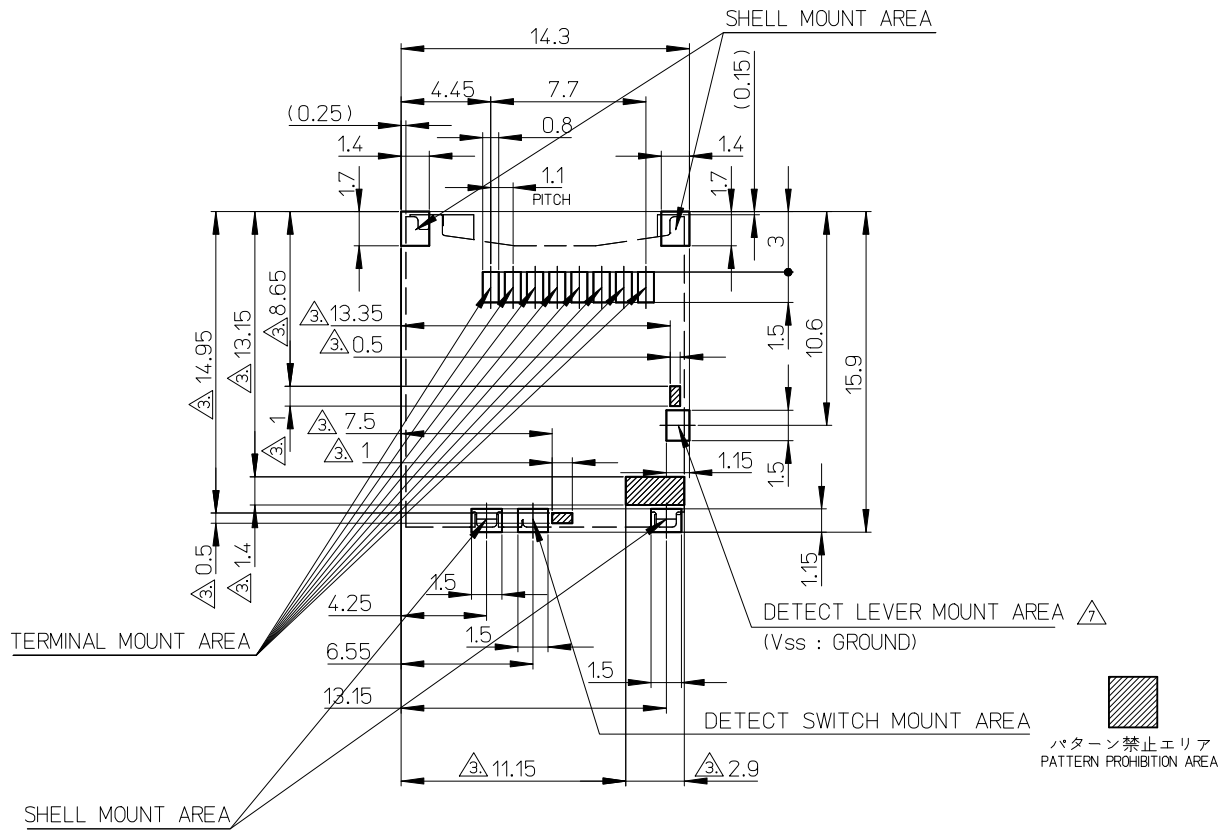

RECOMMENDED
PCB PATTERN LAYOUT
(GENERAL TOLERANCE : ±0.05)

REVISED EC NO: J2009-2308 DRWN: CARIZONO 2009/04/17 CHKD: T. HARIYAMA 2009/04/17 APPR: NUKITA 2009/04/20	GENERAL TOLERANCES (UNLESS SPECIFIED)		DIMENSION STYLE MM ONLY		SCALE 4:1	DESIGN UNITS METRIC	THIRD ANGLE PROJECTION	
	10 UNDER	±0.2	DRAWN BY YMATSUMOTO	DATE 07/09/10	TITLE MICROSD CARD CONN. (P/P & NORMALSMALL TYPE)			
	10 OVER 30 UNDER	±0.25	CHECKED BY MTOMITA	DATE 07/09/10				
	30 OVER	±0.3	APPROVED BY MSASAO	DATE 07/09/10	MATERIAL NO. SEE SHEET 1			
ANGULAR ±1 °		MATERIAL NO. SEE SHEET 1		DOCUMENT NO. SD-502570-001				
DRAFT WHERE APPLICABLE MUST REMAIN WITHIN DIMENSIONS		THIS DRAWING CONTAINS INFORMATION THAT IS PROPRIETARY TO MOLEX INCORPORATED AND SHOULD NOT BE USED WITHOUT WRITTEN PERMISSION						

NOTES

- 製品詳細寸法については、SD 図面を参照下さい。
RE DETAILED DIMENSION, SEE SALES DRAWING.
- 梱包数量：1300 個／リール
NUMBER OF CONNECTORS：1300 PCS/REEL.
- リードテープ長さ LEAD TAPE LENGTH.
トップテープ接着部
TOP TAPE BONDED PART.
(空エンボス)
(EMPTY)
100 MIN.
引き出し方向
PULL OUT DIRECTION
- トップテープの剥離強度：JIS C0806-3に準拠(剥離方向は下図参照)
尚、本規格値は出荷時に適用。(但し、輸送時に剥離が発生しないこと。)
PEELING OFF FORCE OF TOP TAPE : BASED UPON JIS C0806-3
(PEELING DIRECTION AS SHOWN IN FOLLOWING FIG.)
THIS REQUIREMENT SHOULD BE APPLIED AT SHIPMENT.
PEEL OFF SHOULD NOT BE ALLOWED, DURING TRANSPORTATION.
剥離方向
PEEL OFF DIRECTION
10°
引き出し方向
PULL OUT DIRECTION
- 材料 MATERIAL
キャリアテープ (CARRIER TAPE)：ポリスチレン (POLYSTYRENE)
トップテープ (TOP TAPE)：PET, PE, PEF
リール (REEL)：ポリスチレン (PS) <リサイクル材含む>
POLYSTYRENE (PS) <RECYCLE MATERIAL CONTAINED>
- ELV及びRoHS適合品 ELV AND RoHS COMPLIANT

引き出し方向
PULL OUT DIRECTION

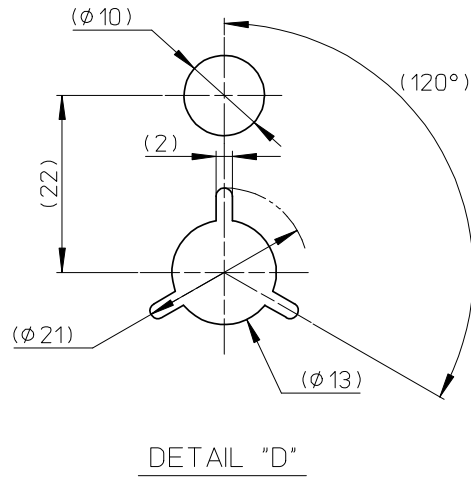
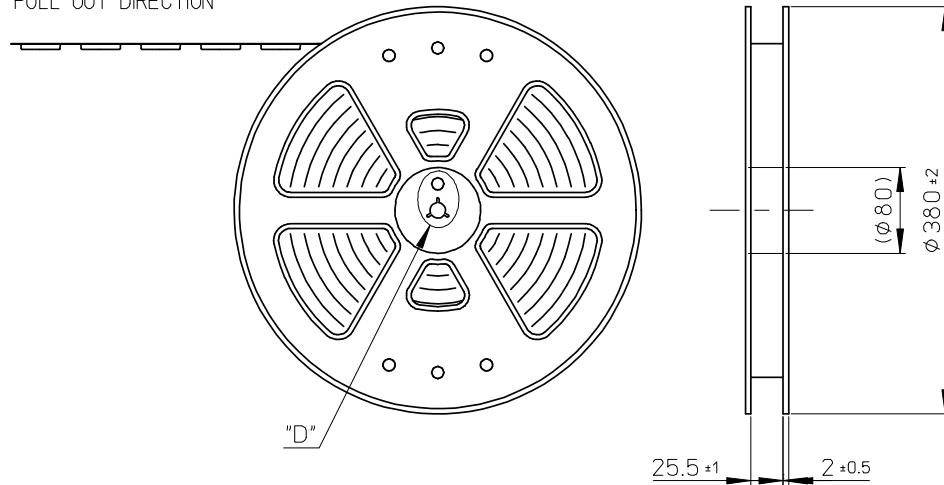

引き出し方向
PULL OUT DIRECTION

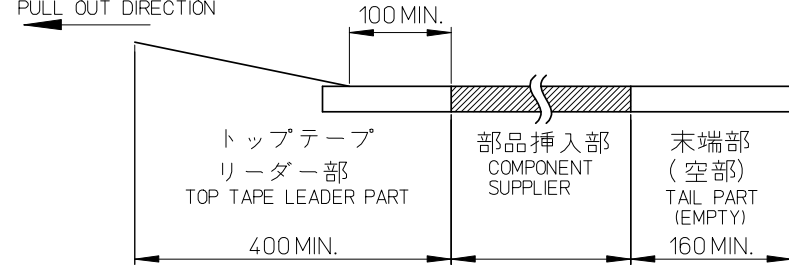

- トップテープの剥離強度：JIS C0806-3に準拠(剥離方向は下図参照)
尚、本規格値は出荷時に適用。(但し、輸送時に剥離が発生しないこと。)
PEELING OFF FORCE OF TOP TAPE : BASED UPON JIS C0806-3
(PEELING DIRECTION AS SHOWN IN FOLLOWING FIG.)
THIS REQUIREMENT SHOULD BE APPLIED AT SHIPMENT.
PEEL OFF SHOULD NOT BE ALLOWED, DURING TRANSPORTATION.

引き出し方向
PULL OUT DIRECTION

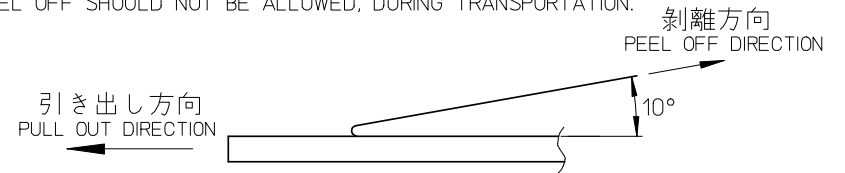

- 材料 MATERIAL
キャリアテープ (CARRIER TAPE)：ポリスチレン (POLYSTYRENE)
トップテープ (TOP TAPE)：PET, PE, PEF
リール (REEL)：ポリスチレン (PS) <リサイクル材含む>
POLYSTYRENE (PS) <RECYCLE MATERIAL CONTAINED>

8. ELV及びRoHS適合品 ELV AND RoHS COMPLIANT

502570-0831	502570-0893	502570-08**
CONNECTOR	MATERIAL NO.	MODEL NO.

RELEASED EC NO: J2008-3223 DR: W. H. Y. J. I. M. A. 2008/03/10 CH: K. D. T. H. A. R. U. Y. A. M. A. 2008/03/11 APPR: N. U. K. I. T. A. 2008/03/11	GENERAL TOLERANCES (UNLESS SPECIFIED)		DIMENSION STYLE MM ONLY		SCALE 4:1	DESIGN UNITS METRIC	THIRD ANGLE PROJECTION	
	10 UNDER	±0.2	DRAWN BY YMATSUMOTO	DATE 07/09/10	TITLE MICROSD CARD CONN. EMBOSSED TYPE PACKAGE FOR 502570-08**			
	10 OVER 30 UNDER	±0.25	CHECKED BY MTOMITA	DATE 07/09/10				
	30 OVER	±0.3	APPROVED BY MSASAO	DATE 07/09/10	MOLEX INCORPORATED DOCUMENT NO. SD-502570-002 SHEET NO. 1 OF 2			
	ANGULAR	±1 °	MATERIAL NO.					
DRAFT WHERE APPLICABLE MUST REMAIN WITHIN DIMENSIONS		SEE TABLE		THIS DRAWING CONTAINS INFORMATION THAT IS PROPRIETARY TO MOLEX INCORPORATED AND SHOULD NOT BE USED WITHOUT WRITTEN PERMISSION				

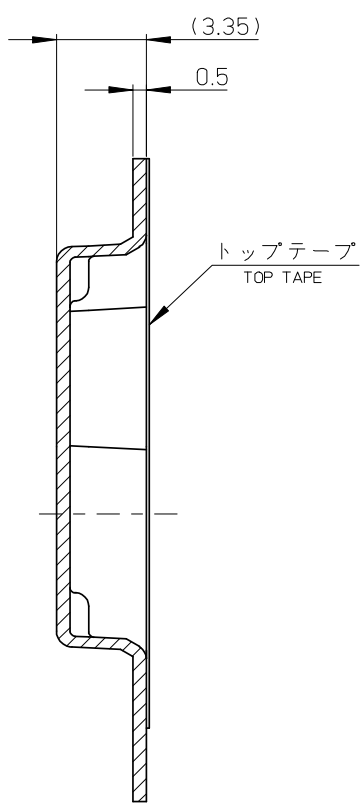

SECTION X-X

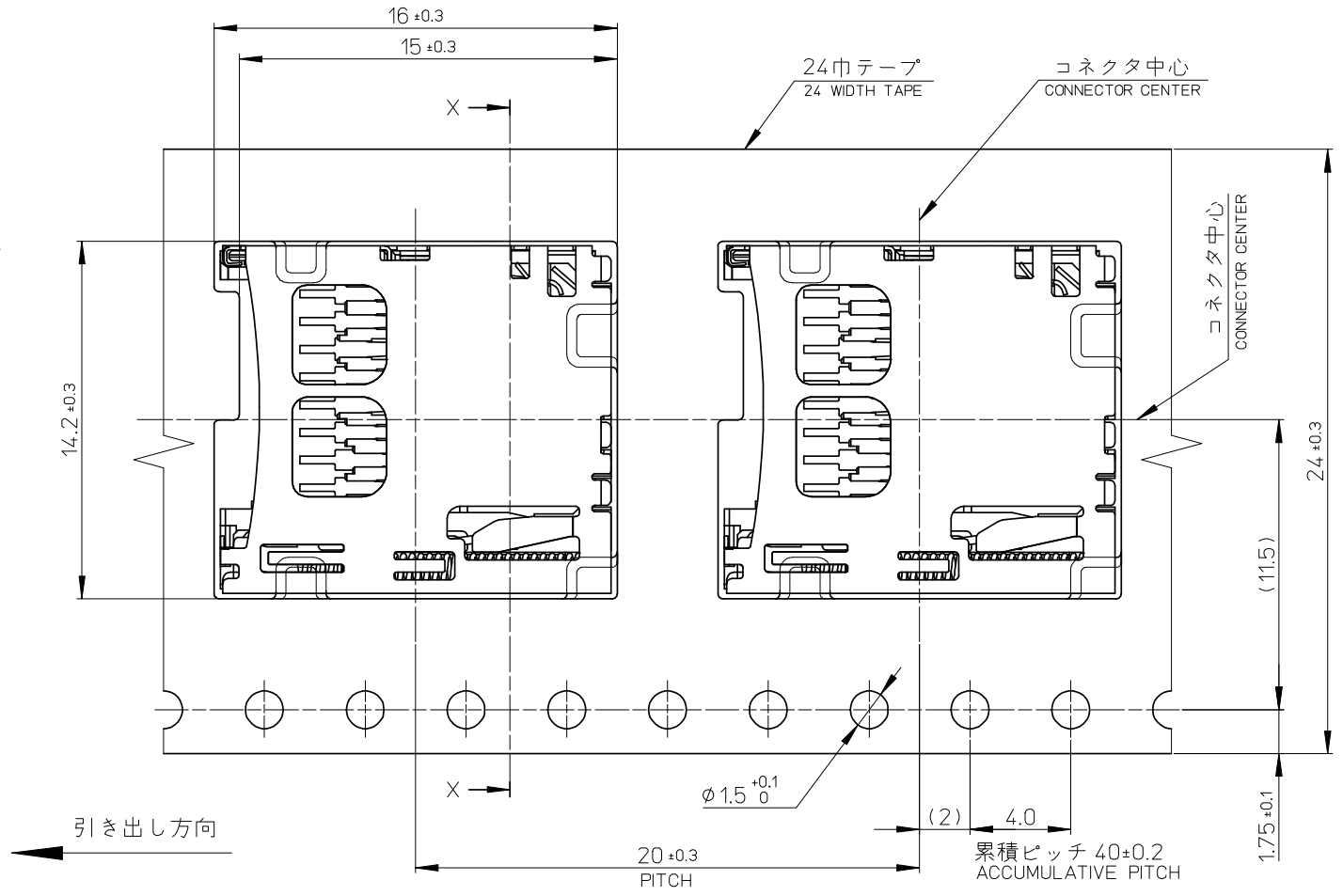

引き出し方向

RELEASED EC NO: J2008-3223 DRW:HYAJIMA 2008/03/10 CH:K:THARUYAMA 2008/03/11 APPR:NUKITA 2008/03/11	GENERAL TOLERANCES (UNLESS SPECIFIED)		DIMENSION STYLE MM ONLY		SCALE 4:1	DESIGN UNITS METRIC	THIRD ANGLE PROJECTION	
	10 UNDER	± 0.2	DRAWN BY YMATSUMOTO	DATE 07/09/10	TITLE MICROSD CARD CONN. EMBOSSSED TYPE PACKAGE FOR 502570-08**			
	10 OVER 30 UNDER	± 0.25	CHECKED BY MTOMITA	DATE 07/09/10				
	30 OVER	± 0.3	APPROVED BY MSASAO	DATE 07/09/10	MOLEX INCORPORATED			
	ANGULAR	± 1 °	MATERIAL NO.	DOCUMENT NO.				
DRAFT WHERE APPLICABLE MUST REMAIN WITHIN DIMENSIONS			SEE SHEET 1		SD-502570-002	2 OF 2		