

**KNOB**

AISI CF-8 stainless steel, sandblasted matte finish.

**STATOR**

AISI 303 stainless steel.

**PACKING RING**

Silicone directly applied onto the back side of the stator head.

**NUT**

M22x1.5 in AISI 303 stainless steel.

**CLOSING LEVER**

AISI 304 stainless steel.

**UNDULATED WASHER**

Stainless steel.

**SCREW**

M6x10 in stainless steel.

**INTERNAL GASKET**

NBR synthetic rubber.

**ROTATION ANGLE**

90°.

**IP PROTECTION**

IP 65 protection class, according to EN 60529 (see page A-18).

**FEATURES AND APPLICATIONS**

Clamping range from 6 to 50 millimetres.

The internal O-ring prevents the ingress of water.

**ACCESSORIES ON REQUEST**

Punch tool GN 123 (see page 1557) facilitates the execution of the drilling template.

**ASSEMBLY INSTRUCTIONS**

1. Drill a hole in the door as per the drilling template with the axis at a distance of 30 mm from the door frame.
2. Insert frontally the latch body in the hole of the door and screw on the threaded nut.
3. Insert the locking lever with the threaded screw.



Drilling template

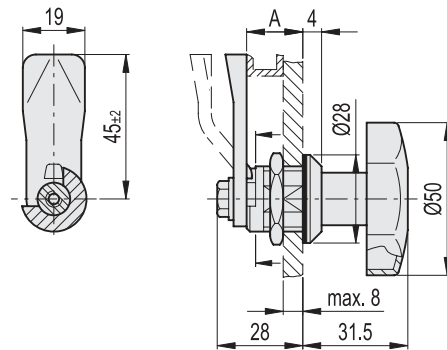
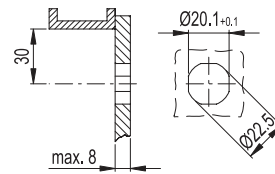

Code	Description	A	Δ
68851	VCML.50-SST-45-6	6	80
68853	VCML.50-SST-45-10	10	88
68855	VCML.50-SST-45-14	14	96
68857	VCML.50-SST-45-18	18	105
68859	VCML.50-SST-45-20	20	114
68861	VCML.50-SST-45-22	22	130
68863	VCML.50-SST-45-24	24	140
68865	VCML.50-SST-45-26	26	150
68867	VCML.50-SST-45-28	28	160
68871	VCML.50-SST-45-30	30	170
68873	VCML.50-SST-45-34	34	185
68875	VCML.50-SST-45-38	38	195
68877	VCML.50-SST-45-40	40	210
68879	VCML.50-SST-45-50	50	260

