

REVISIONS					
REV	ECO	DESCRIPTION	DATE	BY	APPR
A1	-	FIRST RELEASED	Jul-31-2019	Ronald	Tommy

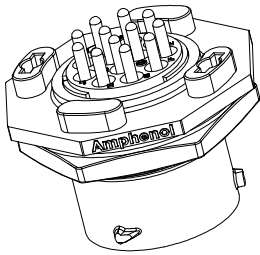

NOTES: (UNLESS OTHERWISE SPECIFIED)

- MATERIAL:
 - SHELL: THERMOPLASTIC, UL94 V-0.
 - INSERT: THERMOPLASTIC, UL94 V-0.
 - O-RING: SILICONE RUBBER.
 - SEAL GASKET: SILICONE RUBBER.
 - JAM NUT: ALUMINIUM ALLOY, BLACK ANODIZING.
 - CONTACT : COPPER ALLOY, GOLD PLATED.
- SPECIFICATIONS:
 - RATED CURRENT: 13A (MAX).
 - RATED VOLTAGE: 500V(AC/DC).
 - OPERATING TEMPERATURE: -40°C ~ 125°C.
 - DIELECTRIC WITHSTANDING VOLTAGE: LESS THAN 2 MILLIAMPS CURRENT LEAKAGE@2000 VOLTS AC.
 - INSULATION RESISTANCE: 5000 MEGOHMS MIN.
 - IP-CLASS: IP67 AND IP69K IN THE MATED CONDITION, PANEL EXTERNAL.
 - MATING CYCLES DURABILITY: 500 CYCLES MIN.
 - RoHS COMPLIANT.
- SUITABLE CONTACTS : 16# CONTACT.
- ALL DIMENSIONS ARE FOR REFERENCE USE ONLY.

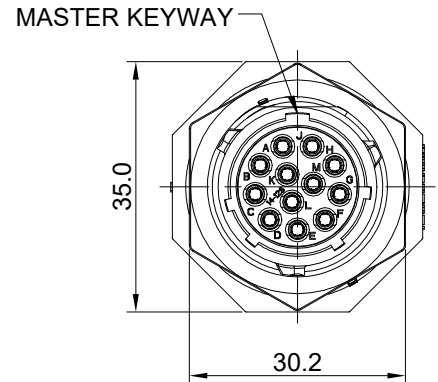
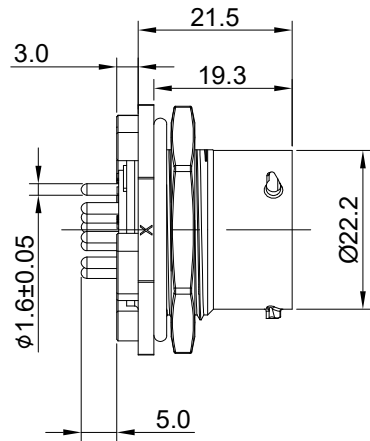
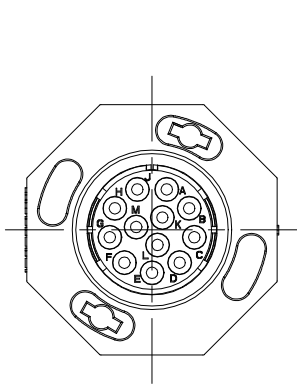
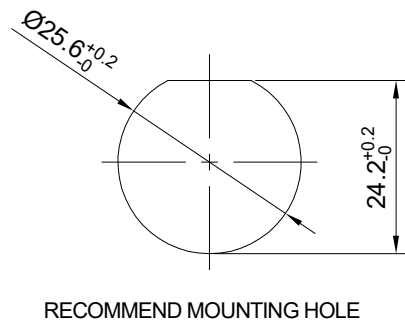

RECOMMEND MOUNTING HOLE

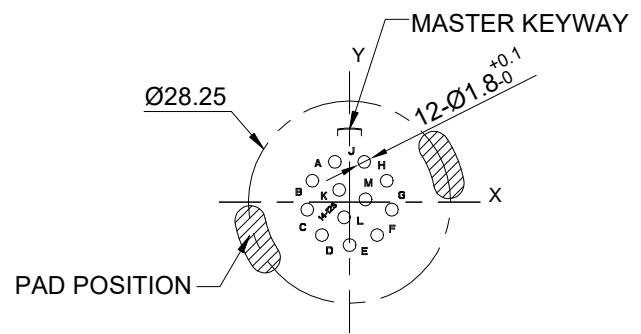

RECOMMEND PCB LAYOUT

Position number	X	Y
A	-2.052	5.638
B	-5.196	3.000
C	-5.909	-1.042
D	-3.857	-4.596
E	0.000	-6.000
F	3.857	-4.596
G	5.909	-1.042
H	5.196	3.000
J	2.052	5.638
K	-1.446	1.724
L	-0.769	-2.114
M	2.215	0.391

KEY	PART NUMBER
N	RTS714ND12S03
W	RTS714WD12S03
X	RTS714XD12S03
Y	RTS714YD12S03
Z	RTS714ZD12S03

QUANTITY	PART NUMBER	DESCRIPTION	ITEM
MATERIALS LIST			
UNLESS OTHERWISE SPECIFIED 1) All dimensions are in metric(mm). 2) Tolerances are as follows: 1 PL DEC ±0.30 Fractions ±1/64 2 PL DEC ±0.15 Angles ±1° 3 PL DEC ±0.08 3) Note reference =		SIGNATURES DATE DRAWN: Ronald Jul-31-2019 CHECKED: Martin Jul-31-2019 ENGINEER: APPROVAL: Tommy Jul-31-2019	Amphenol Sine Systems - www.amphenol-sine.com 44724 Morley Drive Clinton Township, MI 48036
MATERIAL SPECIFICATIONS:		CUSTOMER:	ECO-MATE, RECEPTACLE, JAM NUT, 12POS, SOCKET CONTACT, DIPSOLDER, SIZE 14
PROCESS SPECIFICATIONS:		THIS DRAWING IS SUPPLIED FOR INFORMATION ONLY. DESIGN FEATURES, SPECIFICATIONS AND PERFORMANCE DATA SHOWN HEREON ARE THE PROPERTY OF THE AMPHENOL CORPORATION. NO RIGHTS OF REPRODUCTION ARE IMPLIED. ALL DIMENSIONS ARE SUBJECT TO NORMAL MANUFACTURING VARIATIONS.	SIZE: B TYPE: C- DWG NO: RTS714*D12S03 REVISION: A1 SCALE: NONE RTS714*D12S03 SHEET 1 OF 1
NEXT ASSY:			

TITLE: ECO-MATE, RECEPTACLE, JAM NUT, 12POS, SOCKET CONTACT, DIPSOLDER, SIZE 14
 DWG NO: RTS714*D12S03
 REV: A1
 SH: 1
 OF: 1