

THIS DRAWING IS UNPUBLISHED. RELEASED FOR PUBLICATION ,19 .
 © COPYRIGHT 19 BY AMP INCORPORATED. ALL INTERNATIONAL RIGHTS RESERVED.

LOC	DIST	P	F	REVISIONS				
				ZONE	LTR	DESCRIPTION	DATE	APPD
AR	39				C	REDRAW PER ECN 2252	1/12/89	KIH
					D	REV PER ECN AR2719	11-01-89	KIH
					E	REV PER ECN BD3842	4-18-90	-
					F	REV PER EC 0020-1550-93	01/25/94	GDM

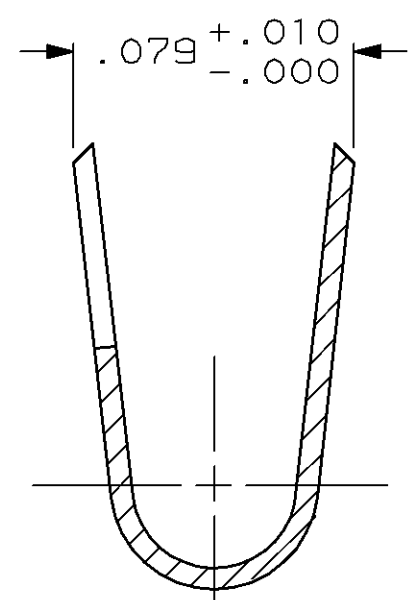
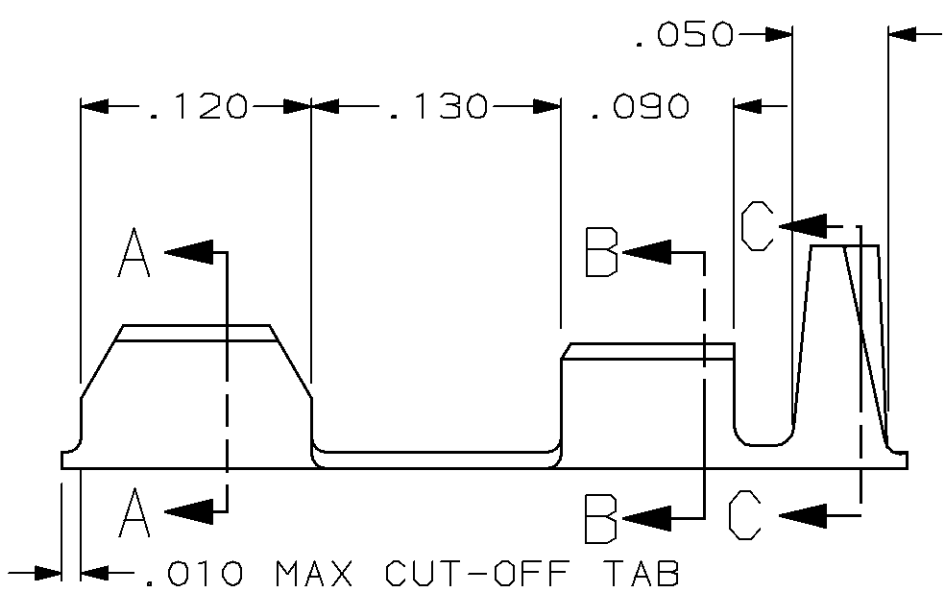
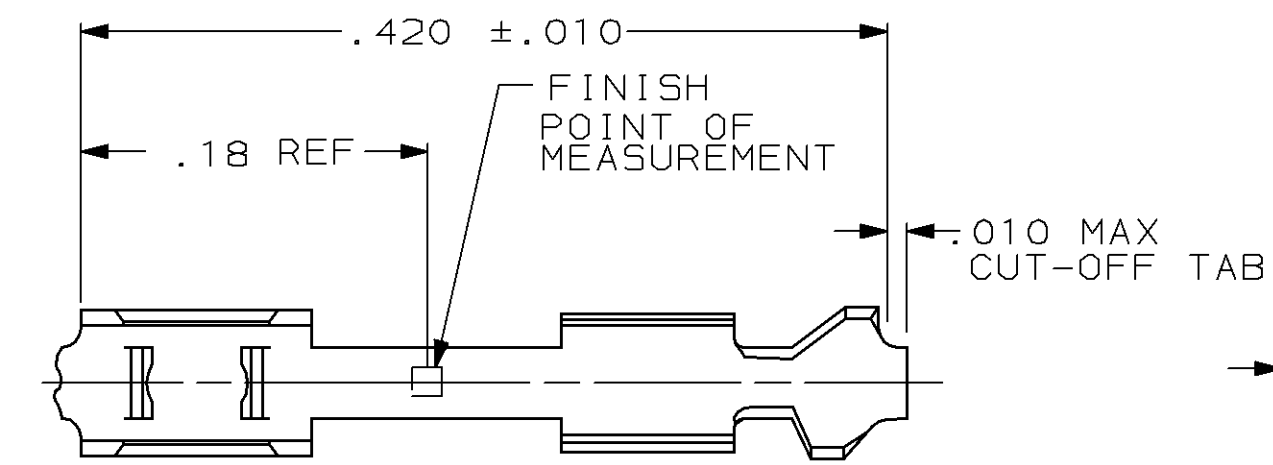

SECT. C-C
 INSULATION RANGE
 ∅.035-.060
 SCALE 20:1

- ① SPLICE IS DESIGNED FOR USE WITH FLEXIBLE FLAT CONDUCTOR CABLE HAVING .015 MAX. THICKNESS AND .060-.065 WIDE CONDUCTORS ON .100 MIN. CENTER TO CENTER SPACING.
- ② OBSOLETE PART NUMBER

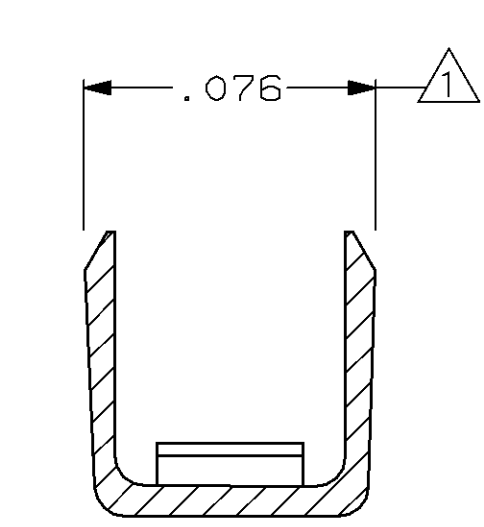

SECT. A-A
 SCALE 20:1

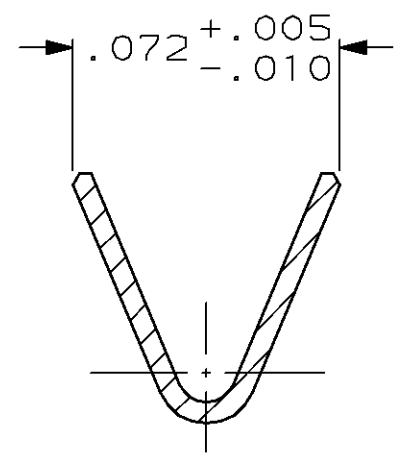

SECT. B-B
 WIRE RANGE
 #22-#26 AWG.
 SCALE 20:1

BRIGHT TIN/LEAD .000100 MIN THK OVER NICKEL .000050 MIN THK OVER ENTIRE CONTACT		②	86774-2
GOLD .000015 OVER NICKEL .000050 MIN THK ON ENTIRE CONTACT			86774-1
FINISH		PART NO	
DO NOT SCALE PRINT. UNLESS SPECIFIED DIMENSIONS IN INCHES TOLERANCES ON: 2 PLC DEC ± - 3 PLC DEC ± .005 ANGLES ± -	DR 1-12-89 K. HELM CHK 2-14-89 D.L. ROCKER APPD 2-17-89 W.T. PARKER APPD 2-16-89 G.D. MILLER PRODUCT SPEC 108-9024	AMP INCORPORATED Harrisburg, Pa. 17105	
MATERIAL PHOSPHOR BRONZE	FINISH SEE CHART	NAME SPLICE CONTACT, STD CRIMP FLAT CABLE TO ROUND WIRE 26-22 AWG, LOOSE PIECE	
	APPLICATION SPEC 114-16002,03	SIZE B	FSCM NO 00779
	WEIGHT -	DRAWING NO 86774	SCALE 10:1
		SHEET 1 OF 1	