



APPROVAL SHEET

Customer Name : _____
Model Name : COOLER
Model Name : FHS-K8020S00
Customer Part No : _____
Spec Issue Date : 2015/3/11
Spec Revision : 04

PLEASE SEND ONE COPY OF THIS SPECIFICATION BACK AFTER YOU
SIGNED APPROVAL FOR PRODUCTION PRE-ARRANGMENT.

Approved By: _____

Date: _____

Approval	Check	Designer
Alex-Hsia	Charles Chen	REEK.LI



Delta Electronics Corp.

REV.	Description	Drawn	Checked	Approved	Issue Date
00	ISSUE SPEC	REEK.LI2011/10/07	Charles. Chen 2011/10/07	Alex-Hsia 2011/10/07	2011/10/07
01	MODIFY INSULATOR TAPE TO 3246134300 & SCREW TO 3105377200	REEK.LI2014/4/10	Charles. Chen 2014/4/10	Alex-Hsia 2014/4/10	2014/4/10
02	CORRECT PACKING SPEC	REEK.LI2014/7/17	Charles. Chen 2014/7/17	Alex-Hsia 2014/7/17	2014/7/17
03	CORRECT BOM MATERIAL ADD MATERIAL RoHS REPORTS ADD FAN UL, CE, VDE CERTIFICATIONS	REEK.LI2014/8/15	Charles. Chen 2014/8/15	Alex-Hsia 2014/8/15	2014/8/15
04	ADD LABEL PN ON PAGE 4 UPDATE RoHS REPORTS	REEK.LI2015/3/11	Charles. Chen 2015/3/11	Alex-Hsia 2015/3/11	2015/3/11
Description: SAMPLE REVISION CODE LIST					
Part No.					REV
DELTA MODEL : FHS-K8020S00			TOTAL <u>146</u> PAGE		04



Delta Electronics Corp.

CONTENTS

Item	Element Description	Page	Note
1	Specification	4	
2	Print	5	
3	Packing Plan	11	
4	Fan	14	
5	MATERIAL RoHS REPORT	33	
6			
7			
8			
9			



Delta Electronics Corp.

1. SPECIFICATION

Characters

Item	Description
Scope	THIS SPECIFICATION DEFINES THE ELECTRICAL AND MECHANICAL CHARACTERISTICS OF THE FAN HEATSINK
Application	INTEL LGA1155 CPU COOLER
Specification	
a: Thermal Resistance	0.37 (°C/W) (REF.)
b: total weight	320 g (REF.)
c: clip force	16 kgf (REF.)

BOM

Item	Part Name	Material	Part NO.	Q'TY	Remark
1	Screw	SWRCH18A	3105371800	2 pce	REV03
2	Screw	SWRCH18A	3105377200	2 pce	REV03
3	Screw	PEM QUICK	3107005700	4 pce	
4	Washer	SK7	3110264300	2 pce	
5	Insulator tape	Mylar	3244675000	2 pce	
6	Insulator tape	PC	3246134300	4 pce	REV01
7	Label	INK+PP+PET	3267133400	1 pce	REV04
8	Fin	AL1100	3346911100	1 pce	
9	Copper base	C1100	3346935800	1 pce	
10	Heatpipe	C1020	3460027900	2 pce	
11	Heatpipe	C1020	3460028200	1 pce	
12	Bracket	SK7	3460457800	1 pce	
13	X-Clip	SK7	3460457900	1 pce	
14	Back plate	PBT	3470651300	1 pce	
15	Screw & bag	SWRCH18A	3534186200	1 pce	REV03
16	Fan	PBT	3622849111	1 pce	
17	Solder	SN42/BI58	4090207000	5.8g	
18	TIM	TC-1996	4021101500	0.14g	
19					



Delta Electronics Corp.



2. PRINT

Assembly Drawing

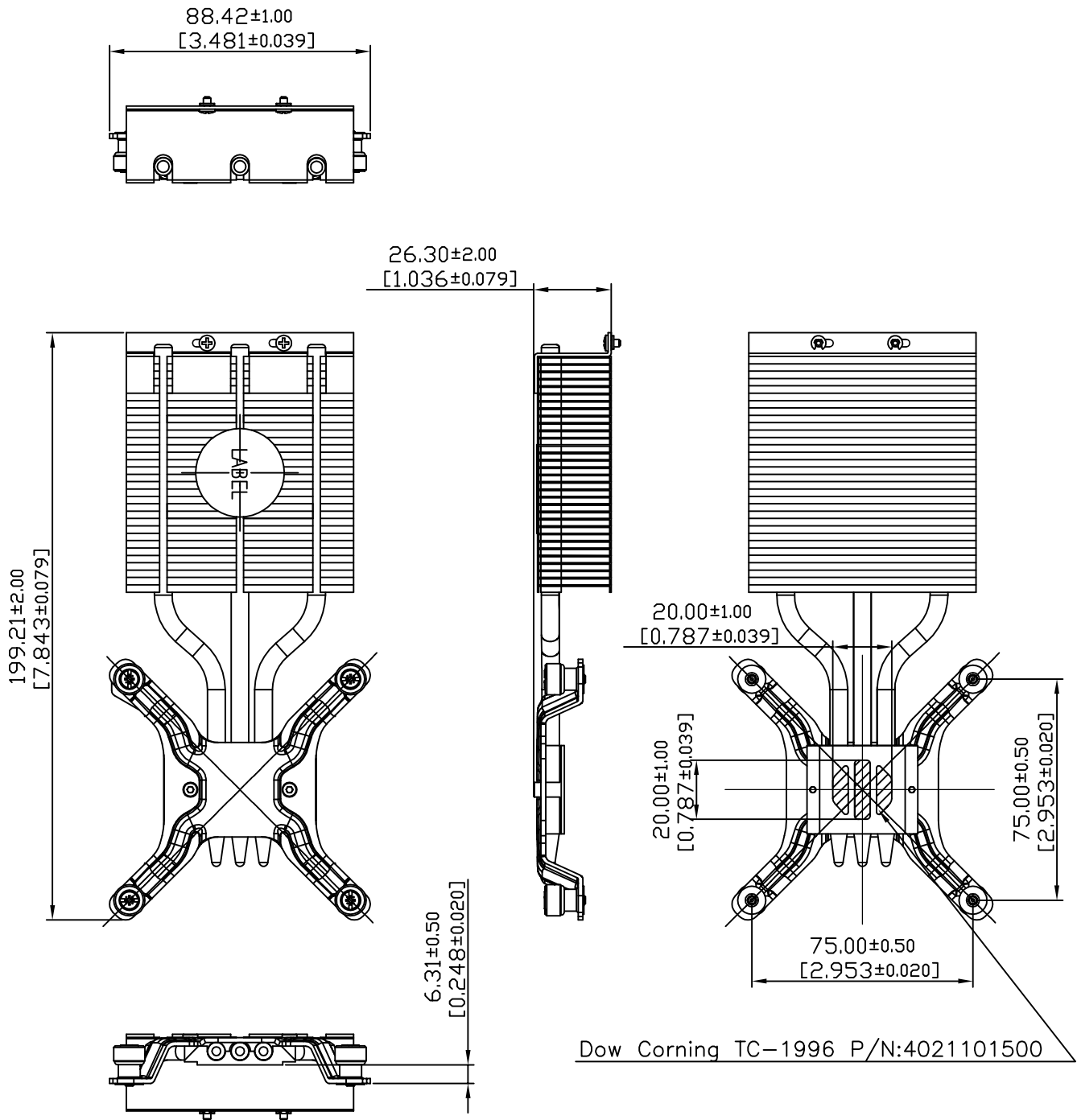
DRAWING:



UNIT: $\frac{\text{mm}}{\text{INCH}}$

 台達電子工業股份有限公司 DELTA ELECTRONICS, INC.	DELTA MODEL: FHS-K8020S00	Drawn: REEK.LI 10/6'11
	CUSTOMER NAME: STD	CUSTOMER P/N: ---
THESE DRAWINGS AND SPECIFICATIONS ARE THE PROPERTY OF DELTA ELECTRONICS, INC. AND SHALL NOT BE REPRODUCED OR USED AS THE BASIS FOR THE MANUFACTURE OR SELL OF APPARATUSES OR DEVICES WITHOUT PERMISSION.	Description: PRODUCTION SPEC. (PHYSICAL DIMENSION)	REV. 00
DIMENSIONAL TOLERANCES	HOLES : ±0.05	ANGLES : ±0.5°
() () () () <30 :±0.25 DECIMALS UP~100 :±0.2 250~300 :±0.4 UP~600 :±1.5 >30~100 :±0.35 X :±0.3 100~150 :±0.25 300~350 :±0.45 600~900 :±2.4 >100~300 :±0.5 X.X :±0.2 150~200 :±0.3 350~400 :±0.5 900~OVER :±3.1 ABOVE 300 :±0.6 X.XX :±0.1 200~250 :±0.35		Part No. FHS-K8020S00-PD
SCALE ---	UNIT mm	USED ON COOLER
SIZE A4	SHEET 1 OF 4	ISSUE DATE:

DRAWING: 3470651300

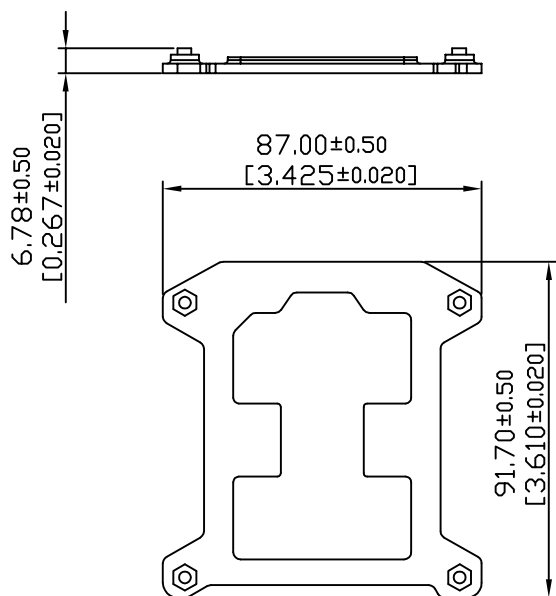
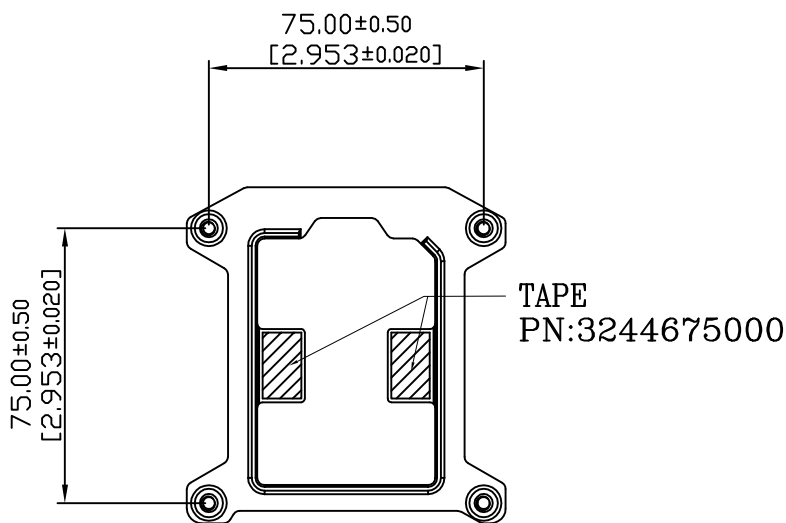

BOTTOM SIDE

UNIT: $\frac{\text{mm}}{\text{(INCH)}}$



台達電子工業股份有限公司
DELTA ELECTRONICS, INC.

DELTA MODEL:
FHS-K8020S00

Drawn:
REEK.LI 10/6'11

THESE DRAWINGS AND SPECIFICATIONS ARE THE PROPERTY OF DELTA ELECTRONICS, INC. AND SHALL NOT BE REPRODUCED OR USED AS THE BASIS FOR THE MANUFACTURE OR SELL OF APPARATUSES OR DEVICES WITHOUT PERMISSION.

CUSTOMER NAME: STD

CUSTOMER P/N: ---

DIMENSIONAL TOLERANCES		HOLES : ±0.05		ANGLES : ±0.5°	
()	()	()	()	()	()
<30	±0.25	DECIMALS	UP~100 :±0.2	250~300 :±0.4	UP~600 :±1.5
>30~100	±0.35	X :±0.3	100~150 :±0.25	300~350 :±0.45	600~900 :±2.4
>100~300	±0.5	XX :±0.2	150~200 :±0.3	350~400 :±0.5	900~OVER :±3.1
ABOVE 300	±0.6	XXX :±0.1	200~250 :±0.35		



Description: PRODUCTION SPEC.
(PHYSICAL DIMENSION)

A4
SIZE

Part No. FHS-K8020S00-PD

REV.

00

SCALE --- UNIT mm USED ON COOLER

SHEET 2 OF 4 ISSUE DATE:

DRAWING: 3622849111

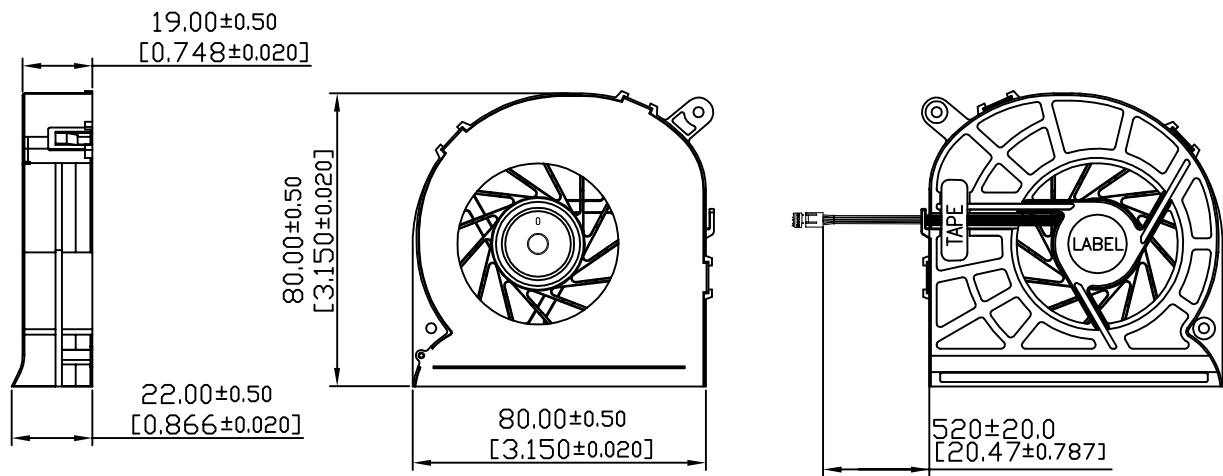

UNIT: $\frac{\text{mm}}{\text{INCH}}$



台達電子工業股份有限公司
DELTA ELECTRONICS, INC.

DELTA MODEL:
FHS-K8020S00

Drawn:
REEK.LI 10/6'11

THESE DRAWINGS AND SPECIFICATIONS ARE THE PROPERTY OF DELTA ELECTRONICS, INC. AND SHALL NOT BE REPRODUCED OR USED AS THE BASIS FOR THE MANUFACTURE OR SELL OF APPARATUSES OR DEVICES WITHOUT PERMISSION.

CUSTOMER NAME: STD
CUSTOMER P/N: ---

DIMENSIONAL TOLERANCES		HOLES : ±0.05		ANGLES : ±0.5°	
()	()	()	()	()	()
<30	±0.25	DECIMALS	UP~100 : ±0.2	250~300 : ±0.4	UP~600 : ±1.5
>30~100	±0.35	X : ±0.3	100~150 : ±0.25	300~350 : ±0.45	600~900 : ±2.4
>100~300	±0.5	XX : ±0.2	150~200 : ±0.3	350~400 : ±0.5	900~OVER : ±3.1
ABOVE 300	±0.6	XXX : ±0.1	200~250 : ±0.35		

Description: PRODUCTION SPEC.
(PHYSICAL DIMENSION)

A4
SIZE

Part No. FHS-K8020S00-PD

REV.
00

SCALE --- UNIT mm USED ON COOLER

SHEET 3 OF 4 ISSUE DATE:

DRAWING: 3534186200

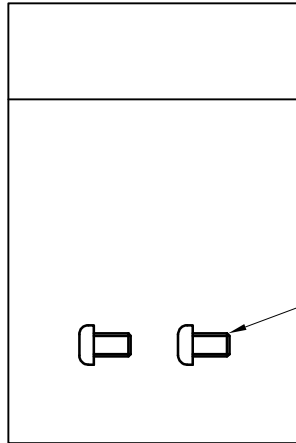

SCREW * 2PCS

UNIT: $\frac{\text{mm}}{\text{〈INCH〉}}$



台達電子工業股份有限公司
DELTA ELECTRONICS, INC.

DELTA MODEL:
FHS-K8020S00

Drawn:
REEK.LI 10/6'11

THESE DRAWINGS AND SPECIFICATIONS ARE THE PROPERTY OF DELTA ELECTRONICS, INC. AND SHALL NOT BE REPRODUCED OR USED AS THE BASIS FOR THE MANUFACTURE OR SELL OF APPARATUSES OR DEVICES WITHOUT PERMISSION.

CUSTOMER NAME: STD

CUSTOMER P/N: ---

DIMENSIONAL TOLERANCES		HOLES : ±0.05		ANGLES : ±0.5°	
()	()	()	()	()	()
<30	±0.25	DECIMALS	UP~100 :±0.2	250~300 :±0.4	UP~600 :±1.5
>30~100	±0.35	X :±0.3	100~150 :±0.25	300~350 :±0.45	600~900 :±2.4
>100~300	±0.5	X.X :±0.2	150~200 :±0.3	350~400 :±0.5	900~OVER :±3.1
ABOVE 300	±0.6	X.XX :±0.1	200~250 :±0.35		



Description: PRODUCTION SPEC.
(PHYSICAL DIMENSION)

A4
SIZE

Part No. FHS-K8020S00-PD

REV.
00

SCALE --- UNIT mm USED ON COOLER

SHEET 4 OF 4 ISSUE DATE:

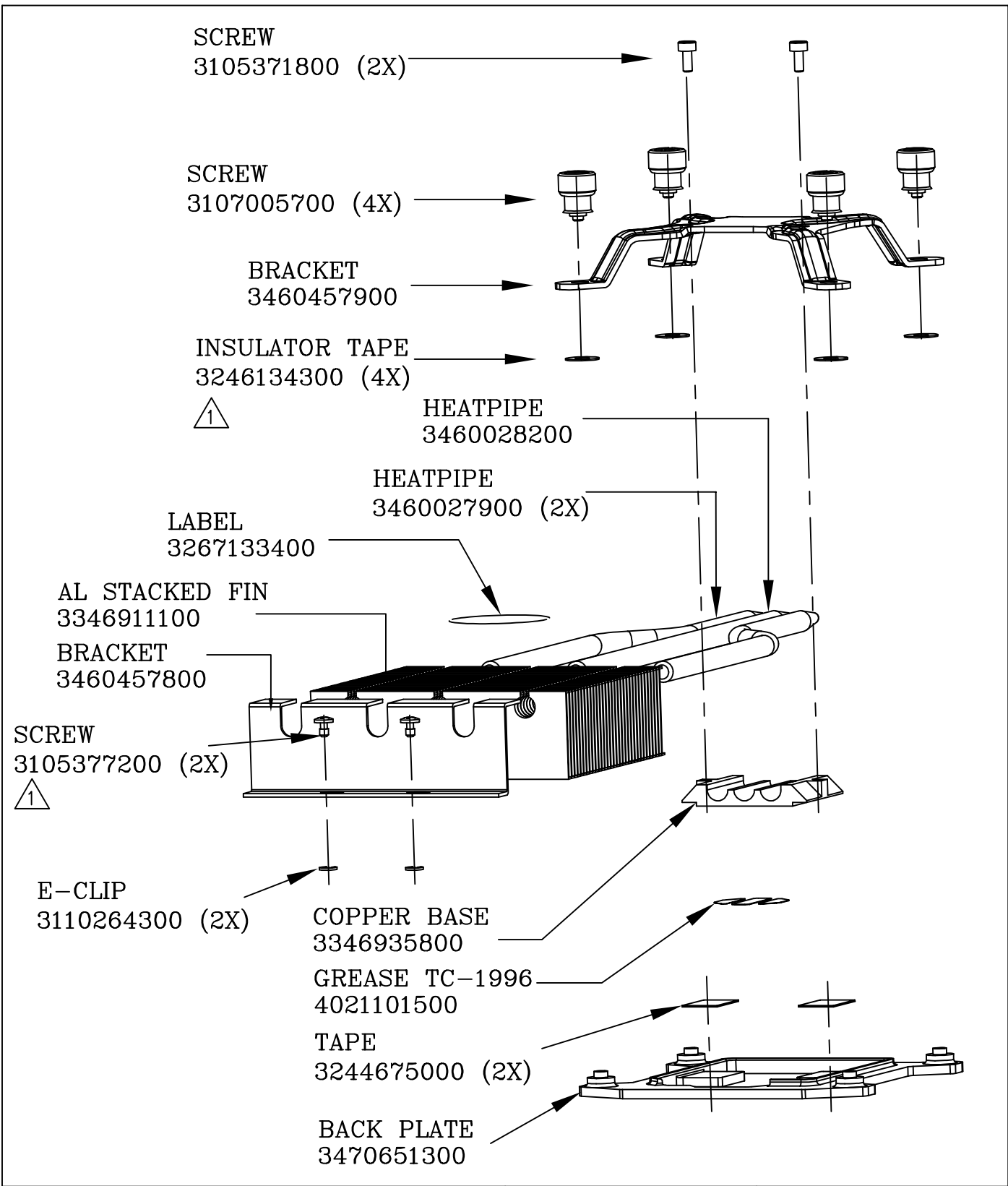

 台達電子工業股份有限公司 DELTA ELECTRONICS, INC.	DELTA MODEL: FHS-K8020S00	Drawn: REEK.LI 4/10'14																																								
	THESE DRAWINGS AND SPECIFICATIONS ARE THE PROPERTY OF DELTA ELECTRONICS, INC. AND SHALL NOT BE REPRODUCED OR USED AS THE BASIS FOR THE MANUFACTURE OR SELL OF APPARATUSES OR DEVICES WITHOUT PERMISSION.																																									
DIMENSIONAL TOLERANCES <small>HOLES : ±0.05 ANGLES : ±0.5°</small> <table border="1"> <tr> <td>()</td> <td>()</td> <td>()</td> <td>()</td> </tr> <tr> <td><30</td> <td>±0.25</td> <td>DECIMALS</td> <td>UP-100 ±0.2</td> </tr> <tr> <td>>30-100</td> <td>±0.35</td> <td>X ±0.3</td> <td>100-150 ±0.25</td> </tr> <tr> <td>>100-300</td> <td>±0.5</td> <td>X.X ±0.2</td> <td>150-200 ±0.3</td> </tr> <tr> <td>ABOVE 300</td> <td>±0.6</td> <td>X.XX ±0.1</td> <td>200-250 ±0.35</td> </tr> <tr> <td></td> <td></td> <td></td> <td>250-300 ±0.4</td> </tr> <tr> <td></td> <td></td> <td></td> <td>300-350 ±0.45</td> </tr> <tr> <td></td> <td></td> <td></td> <td>350-400 ±0.5</td> </tr> <tr> <td></td> <td></td> <td></td> <td>600-900 ±2.4</td> </tr> <tr> <td></td> <td></td> <td></td> <td>900-OVER ±3.1</td> </tr> </table>	()	()	()	()	<30	±0.25	DECIMALS	UP-100 ±0.2	>30-100	±0.35	X ±0.3	100-150 ±0.25	>100-300	±0.5	X.X ±0.2	150-200 ±0.3	ABOVE 300	±0.6	X.XX ±0.1	200-250 ±0.35				250-300 ±0.4				300-350 ±0.45				350-400 ±0.5				600-900 ±2.4				900-OVER ±3.1	Description: PRODUCTION SPEC. (ASSEMBLY ORDER)	Part No. FHS-K8020S00-AS
	()	()	()	()																																						
<30	±0.25	DECIMALS	UP-100 ±0.2																																							
>30-100	±0.35	X ±0.3	100-150 ±0.25																																							
>100-300	±0.5	X.X ±0.2	150-200 ±0.3																																							
ABOVE 300	±0.6	X.XX ±0.1	200-250 ±0.35																																							
			250-300 ±0.4																																							
			300-350 ±0.45																																							
			350-400 ±0.5																																							
			600-900 ±2.4																																							
			900-OVER ±3.1																																							
SCALE --- UNIT mm USED ON COOLER	Description: PRODUCTION SPEC. (ASSEMBLY ORDER)	Part No. FHS-K8020S00-AS																																								
SIZE A4	SHEET 1 OF 1	ISSUE DATE:																																								
		REV. 01																																								



Delta Electronics Corp.

3. PACKING PLAN

Packing Specification

CARTON ILLUSTRATE	SIZE	498(L)*298(w)*270(H)(mm)	PACKING QUANTITY	6LAYERS/CARTON
	MATERIAL	3 LAYERS"AB" FLUTE	CARTON WEIGHT	0.62 kg (REF.)

CARTON OUTSIDE ILLUSTRATE

FRONT

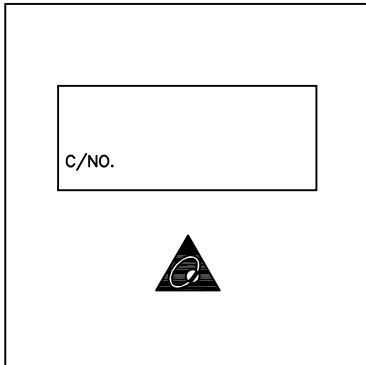

BACK

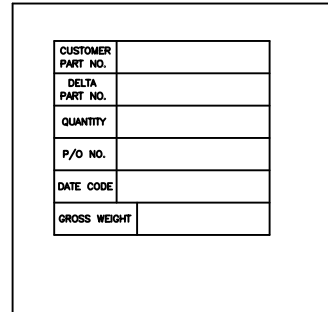

(ONE LABEL PER CARTON)

TRAY PACKING ILLUSTRATE	SIZE	490 (L)*290 (w)*33.8 (H)(mm)	PACKING QUANTITY	3PCS/TRAY
	MATERIAL	PET TRAY		
	MATERIAL WEIGHT	250g (REF.)		

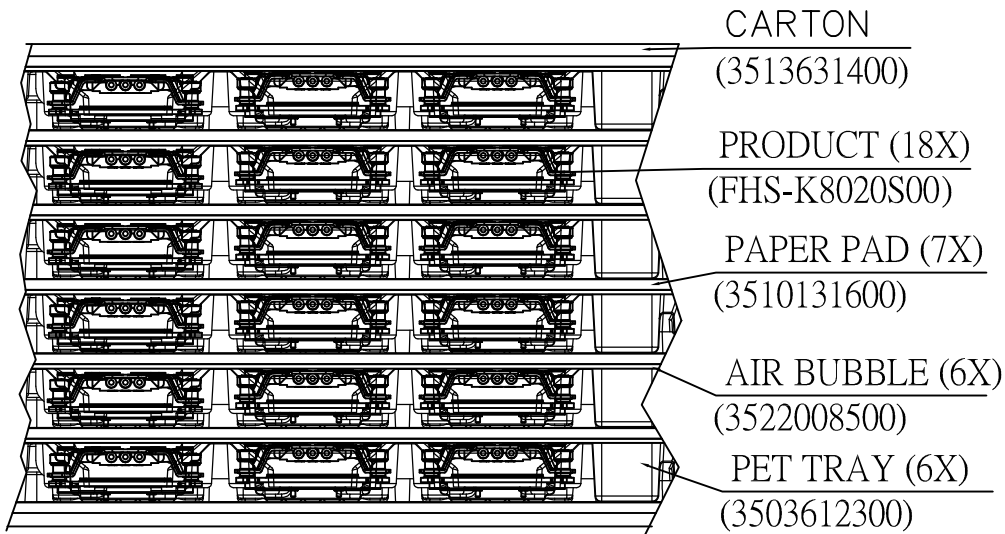

CARTON

(3513631400)

PRODUCT (18X)

(FHS-K8020S00)

PAPER PAD (7X)

(3510131600)

AIR BUBBLE (6X)

(3522008500)

PET TRAY (6X)

(3503612300)



台達電子工業股份有限公司
DELTA ELECTRONICS, INC.

DELTA MODEL:
FHS-K8020S00

Drawn:
REEK.LI 7/17'14

THESE DRAWINGS AND SPECIFICATIONS ARE THE PROPERTY OF DELTA ELECTRONICS, INC. AND SHALL NOT BE REPRODUCED OR USED AS THE BASIS FOR THE MANUFACTURE OR SELL OF APPARATUSES OR DEVICES WITHOUT PERMISSION.

CUSTOMER NAME: STD

CUSTOMER P/N: ---

DIMENSIONAL TOLERANCES		HOLES : ±0.05		ANGLES : ±0.5°	
()	()	()	()	()	()
<30	±0.25	DECIMALS	UP~100 :±0.2	250~300 :±0.4	UP~600 :±1.5
>30~100	±0.35	X :±0.3	100~150 :±0.25	300~350 :±0.45	600~900 :±2.4
>100~300	±0.5	X.X :±0.2	150~200 :±0.3	350~400 :±0.5	900~OVER :±3.1
ABOVE 300	±0.6	X.XX :±0.1	200~250 :±0.35		



Description: PRODUCTION SPEC.
(PACKING ASSMBLY)

A4
SIZE

Part No.
FHS-K8020S00-PA

REV.

SCALE --- UNIT mm USED ON COOLER

SHEET 1 OF 2 ISSUE DATE:

PART NO.	FHS-K8020S00																	
BASIC DATA	QUANTITY/CARTON	18PCS (6 LAYERS/CARTON, 3PCS/LAYER) △																
	PRODUCTION NET WEIGHT	5.8kg (REF.)																
	PRODUCTION GROSS WEIGHT	7.8kg (REF.)																
20(ft)CONTAINER ILLUSTRATE	SIZE	5.889(L)*2.352(w)*2.386(H)m		PACKING QUANTITY														
	CONTAINER	STEEL		20PALLET/CONTAINER														
CONTAINER FORM				20PALLET/CONTAINER														
CONTAINER LOADING METHOD																		
<table border="1"> <tr> <td>PALLET</td> <td>PALLET</td> <td>PALLET</td> <td>PALLET</td> <td>PALLET</td> </tr> <tr> <td>PALLET</td> <td>PALLET</td> <td>PALLET</td> <td>PALLET</td> <td>PALLET</td> </tr> </table> <p style="text-align: center;">TOP VIEW</p>				PALLET	PALLET	PALLET	PALLET	PALLET	PALLET	PALLET	PALLET	PALLET	PALLET	<table border="1"> <tr> <td>PALLET</td> <td>PALLET</td> </tr> <tr> <td>PALLET</td> <td>PALLET</td> </tr> </table> <p style="text-align: center;">FRONT VIEW</p>	PALLET	PALLET	PALLET	PALLET
PALLET	PALLET	PALLET	PALLET	PALLET														
PALLET	PALLET	PALLET	PALLET	PALLET														
PALLET	PALLET																	
PALLET	PALLET																	
PALLET LOADING ILLUSTRATE	SIZE	120(L)*100(w)*15(H)cm		PACKING QUANTITY														
	PALLET	PAPER		24 CARTONS/PALLET														

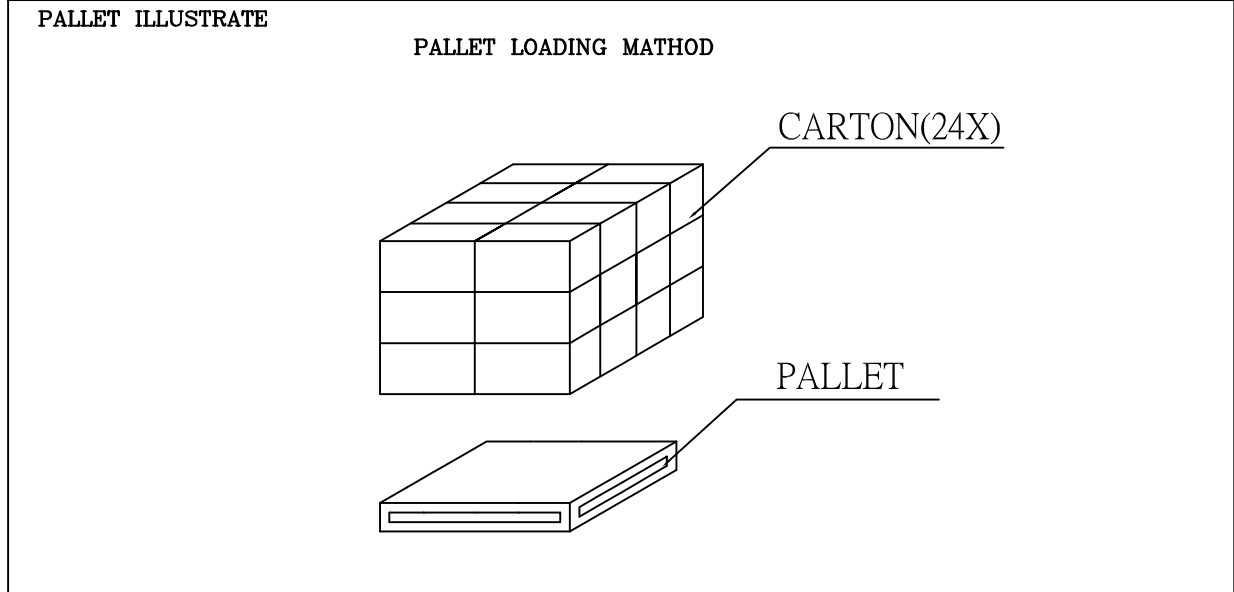

台達電子工業股份有限公司 DELTA ELECTRONICS, INC.	DELTA MODEL: FHS-K8020S00	Drawn: REEK.LI 7/17'14
	THESE DRAWINGS AND SPECIFICATIONS ARE THE PROPERTY OF DELTA ELECTRONICS, INC. AND SHALL NOT BE REPRODUCED OR USED AS THE BASIS FOR THE MANUFACTURE OR SELL OF APPARATUSES OR DEVICES WITHOUT PERMISSION.	
DIMENSIONAL TOLERANCES () () () () <30 :±0.25 DECIMALS UP~100 :±0.2 250~300 :±0.4 UP~600 :±1.5 >30~100 :±0.35 X :±0.3 100~150 :±0.25 300~350 :±0.45 600~900 :±2.4 >100~300 :±0.5 XX :±0.2 150~200 :±0.3 350~400 :±0.5 900~OVER :±3.1 ABOVE 300 :±0.6 XXX :±0.1 200~250 :±0.35	HOLES : ±0.05 ANGLES : ±0.5° 	Description: PRODUCTION SPEC. (PACKING ASSMBLY)
	SCALE --- UNIT mm USED ON COOLER	Part No. FHS-K8020S00-PA
SIZE A4		SHEET 2 OF 2 ISSUE DATE:



Delta Electronics Corp.

4. FAN

Fan Specification



SPECIFICATION FOR APPROVAL

Customer T M P B U

Description D C B L O W E R

Customer P/N: 3 6 2 2 8 4 9 1 1 1 R E V .

Delta Model No. KDB0712HB-BD22 R E V . 00

Sample Issue No.

Sample Issue Date JUL.28.2011

PLEASE SEND ONE COPY OF THIS SPECIFICATION BACK
AFTER YOU SIGNED APPROVAL FOR PRODUCTION PRE-
ARRANGMENT.

APPROVED BY:

DATE :

DELTA ELECTRONICS, INC.
TAOYUAN PLANT
252, SHANG YING ROAD, KUEI SAN INDUSTRIAL ZONE TAOYUAN
SHIEN, TAIWAN, R.O.C.
TEL:886-(0)3-3591968
FAX:886-(0)3-3591991

DELTA ELECTRONICS, INC.
 252, SHANG YING ROAD, KUEI SAN
 TAOYUAN HSIEN 333, TAIWAN, R. O. C.

TEL : 886-(0)3-3591968
 FAX : 886-(0)3-3591991

SPECIFICATION FOR APPROVAL

Customer: TMPBU

 Description: DC BLOWER

 Customer P/N: **3622849111** REV:

 Delta Model NO.: KDB0712HB-BD22 **Delta Safety Model NO.: KDB0712HB**

 Sample Rev: 00 Issue NO:

 Sample Issue Date: **JUL.28.2011** Quantity:

1. SCOPE:

THIS SPECIFICATION DEFINES THE ELECTRICAL AND MECHANICAL CHARACTERISTICS OF THE DC BRUSHLESS AXIAL FLOW FAN. THE FAN MOTOR IS WITH SINGLE PHASE AND FOUR POLES.

2. CHARACTERS:

ITEM	DESCRIPTION
RATED VOLTAGE	12.0 VDC
OPERATION VOLTAGE	10.8 - 12.6 VDC
INPUT CURRENT	0.23 (MAX. 0.45) A (SAFETY CURRENT 0.45 A)
INPUT POWER	2.76 (MAX. 5.40) W
SPEED	3400±10% R.P.M.
MAX. AIR FLOW (AT ZERO STATIC PRESSURE)	0.357 (MIN. 0.314) M ³ /MIN. 12.61 (MIN. 10.32) CFM
MAX. AIR PRESSURE (AT ZERO AIRFLOW)	10.99 (MIN. 8.424) mmH ₂ O 0.433 (MIN. 0.351) inchH ₂ O
ACOUSTICAL NOISE (AVG.)	42.5 (MAX. 46.5) dB-A (AT 50CM)
INSULATION TYPE	UL: CLASS A

(continued)

PART NO: 3622849111

DELTA MODEL: KDB0712HB-BD22

INSULATION STRENGTH	10 MEG OHM MIN. AT 500 VDC (BETWEEN FRAME AND (+) TERMINAL)
DIELECTRIC STRENGTH	5 mA MAX. AT 500 VAC 50/60 Hz ONE MINUTE, (BETWEEN FRAME AND (+) TERMINAL)
LIFE EXPECTANCE	30,000 HOURS CONTINUOUS OPERATION AT 50 °C WITH 15 ~ 65 %RH.
ROTATION	CLOCKWISE VIEW FROM TOP SIDE VIEW
OVER CURRENT SHUT DOWN	THE CURRENT WILL SHUT DOWN WHEN LOCKING ROTOR
LEAD WIRE	UL1061 AWG#28 BLACK WIRE: (-) YELLOW WIRE: (+) GREEN WIRE: (FOO) BLUE WIRE: (PWM)

- NOTES: 1. ALL READINGS ARE MEASURED AFTER STABLY WARMING UP THROUGH 10 MINUTES.
2. THE VALUES WRITTEN IN PARENS , (), ARE LIMITED SPEC.
3. ACOUSTICAL NOISE MEASURING CONDITION:

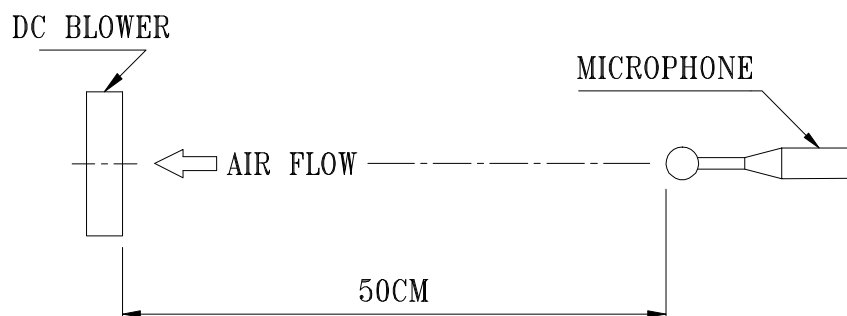

NOISE IS MEASURED AT RATED VOLTAGE IN FREE AIR IN ANECHOIC CHAMBER WITH B & K SOUND LEVEL METER WITH MICROPHONE AT A DISTANCE OF ONE METER FROM THE FAN INTAKE.

PART NO: **3622849111**

DELTA MODEL: KDB0712HB-BD22

3. MECHANICAL:

- 3-1. DIMENSIONS ----- SEE DIMENSIONS DRAWING
- 3-2. FRAME ----- PLASTIC UL: 94V-0
- 3-3. IMPELLER ----- PLASTIC UL: 94V-0
- 3-4. COVER ----- SECC
- 3-5. BEARING SYSTEM ----- FDB BEARING
- 3-6. WEIGHT ----- 44.50 GRAMS

4. ENVIRONMENTAL:

- 4-1. OPERATING TEMPERATURE ----- 0 TO +60 DEGREE C
- 4-2. STORAGE TEMPERATURE ----- -10 TO +75 DEGREE C
- 4-3. OPERATING HUMIDITY ----- 5 TO 90 % RH
- 4-4. STORAGE HUMIDITY ----- 5 TO 95 % RH

5. PROTECTION:

5-1. LOCKED ROTOR PROTECTION

IMPEDANCE OF MOTOR WINDING PROTECTS MOTOR FROM FIRE IN 96 HOURS OF LOCKED ROTOR CONDITION AT THE RATED VOLTAGE.

5-2. POLARITY PROTECTION

BE CAPABLE OF WITHSTANDING IF REVERSE CONNECTION FOR POSITIVE AND NEGATIVE LEADS.

6. RE OZONE DEPLETING SUBSTANCES:

- 6-1. NO CONTAINING PBBs, PBBOs, CFCs, PBBEs, PBDPEs AND HCFCs.

7. PRODUCTION LOCATION

- 7-1. PRODUCTS WILL BE PRODUCED IN CHINA OR THAILAND OR TAIWAN.

PART NO: 3622849111

DELTA MODEL: KDB0712HB-BD22

8. PQ CURVE:

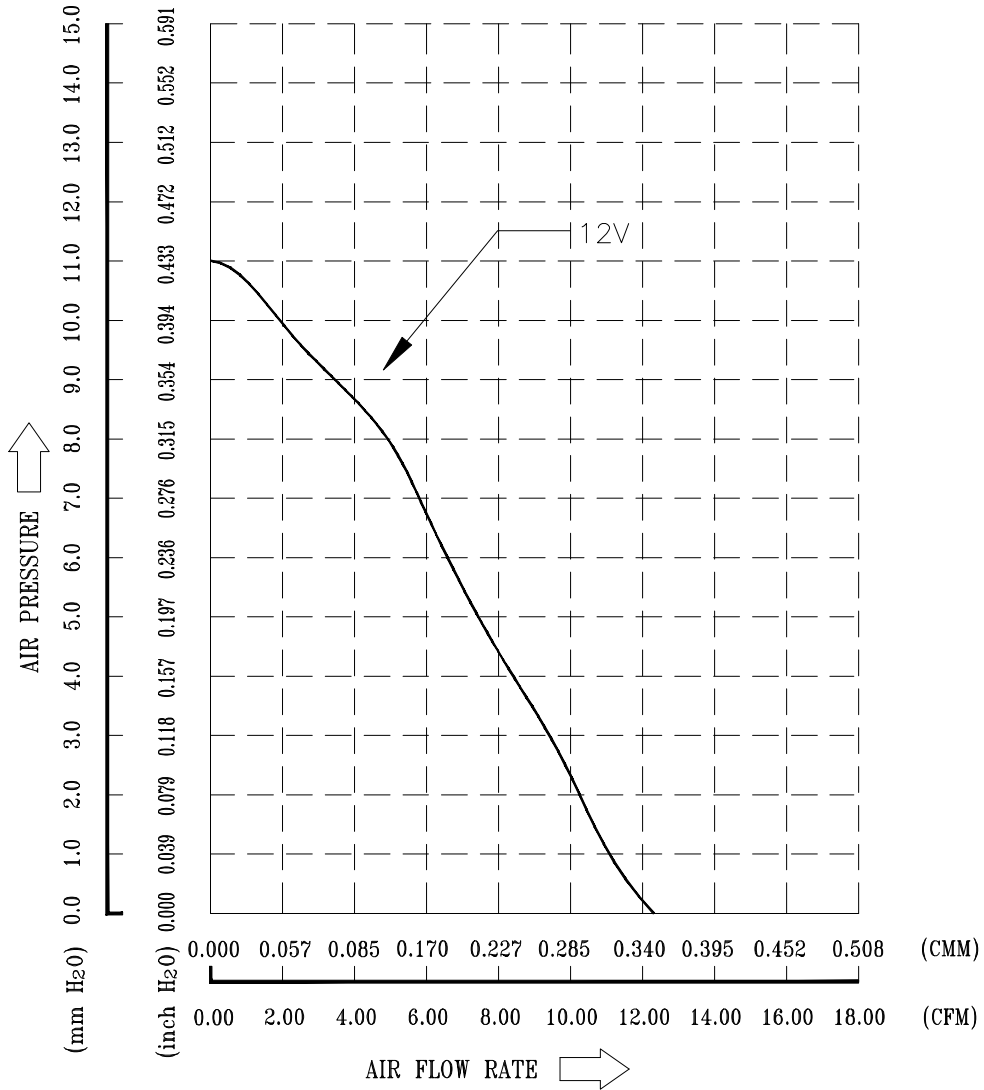

* TEST CONDITION: INPUT VOLTAGE ----- OPERATION VOLTAGE
TEMPERATURE ----- ROOM TEMPERATURE
HUMIDITY ----- 65%RH

PART NO: 3622849111

DELTA MODEL: KDB0712HB-BD22

9. DIMENSION DRAWING:

LABEL:

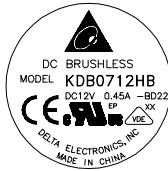

OR

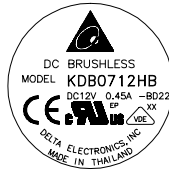

OR

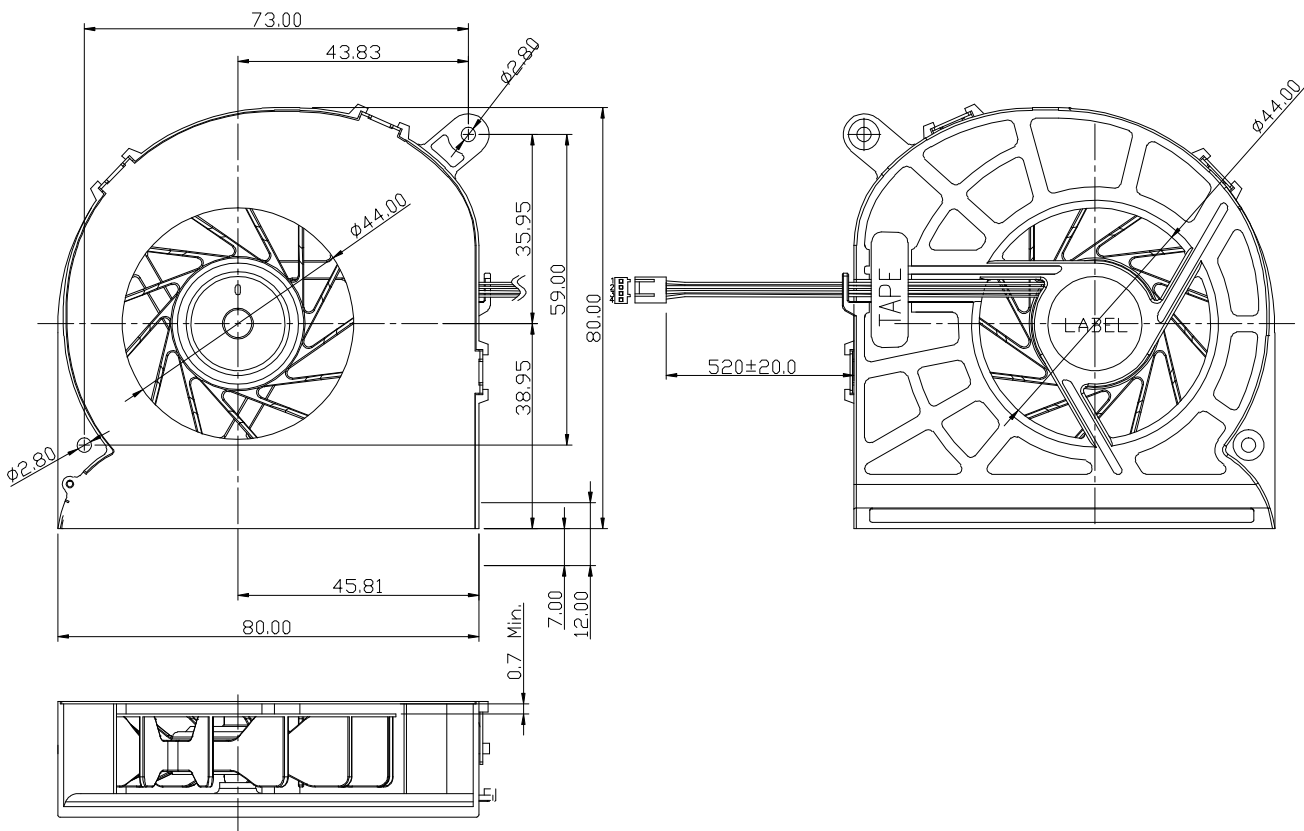
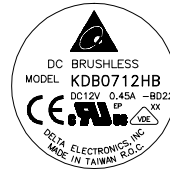

NOTES:

UNIT: mm

- 1.LEAD WIRE: UL1061 AWG#28
PIN 1: BLACK WIRE: NEGATIVE(-)
PIN 2: YELLOW WIRE: POSITIVE(+)
PIN 3: GREEN WIRE: TACHOMETER OUTPUT (F00)
PIN 4: BLUE WIRE: SPEED CONTROL (PWM)
- 2.HOUSING: MOLEX 47054-1000 OR EQUIVALENT
- 3.TERMINAL: MOLEX 2759T 08-50-0113 OR EQUIVALENT
- 4.INSULATOR: TAPE ACETATE
- 5.THIS PRODUCT IS RoHS COMPLIANT

PART NO: 3622849111

DELTA MODEL: KDB0712HB-BD22

10. FREQUENCY GENERATOR (FG) SIGNAL:

10-1. OUTPUT CIRCUIT - OPEN COLLECTOR MODE:

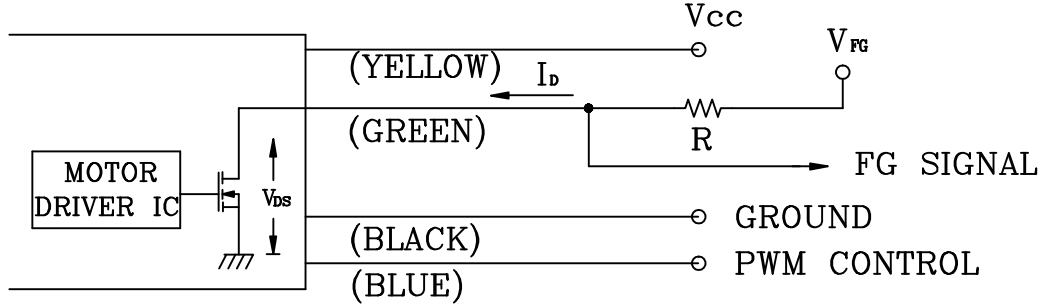

CAUTION: THE FG SIGNAL LEAD WIRE MUST BE KEPT AWAY FROM
" + " LEAD WIRE & " - " LEAD WIRE.

10-2. SPECIFICATION:

V_{DS} (linear) = 0.5V MAX.

V_{FG} = 5.0V TYP. (V_{CC} MAX.)

I_b = 5mA MAX.

$R \geq V_{FG} / I_b$

10-3. FREQUENCY GENERATOR WAVEFORM:

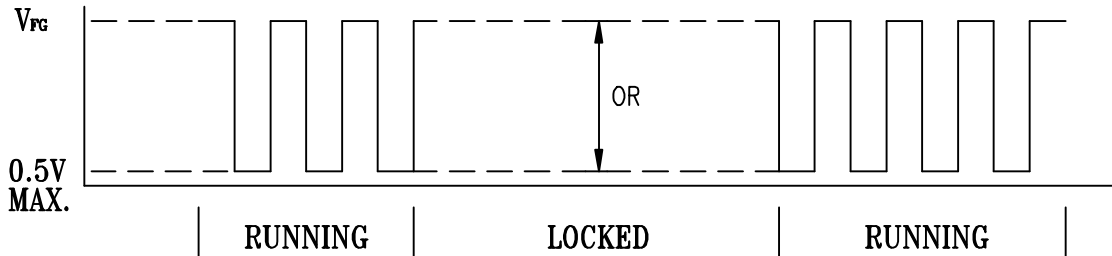

FAN RUNNING FOR 4 POLES

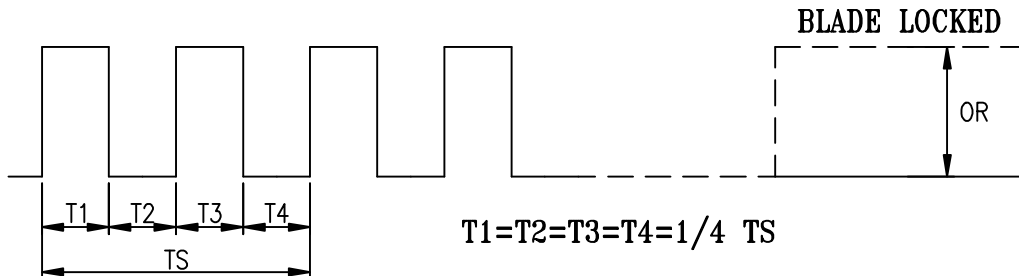

$N = R.P.M$

$TS = 60 / N (SEC)$

*VOLTAGE LEVEL AFTER BLADE LOCKED

*4 POLES

A00

PART NO: 3622849111

DELTA MODEL: KDB0712HB-BD22

11. PWM CONTROL SIGNAL:

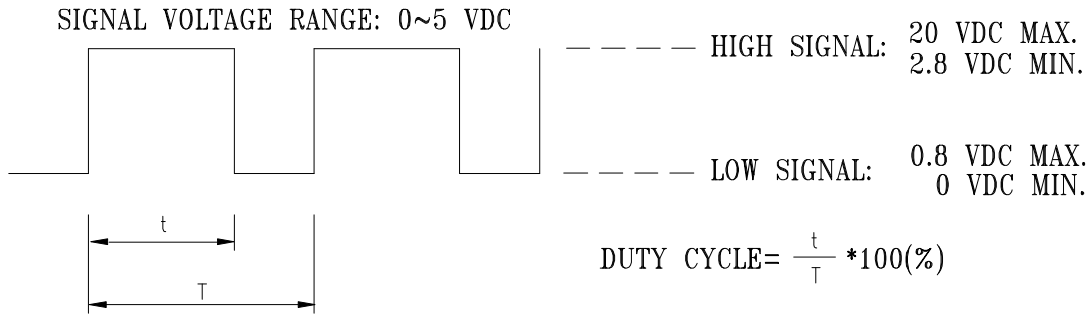

- THE FREQUENCY FOR CONTROL SIGNAL OF THE FAN SHALL BE ABLE TO ACCEPT A 30HZ~300KHZ.
- THE PREFERRED OPERATING POINT FOR THE FAN IS 25K HZ.
- AT 100% DUTY CYCLE,THE ROTOR WILL SPIN AT MAXIMUM SPEED.
- AT 0% ~ 20% DUTY CYCLE,THE ROTOR WILL SPIN AT MINIMUM SPEED.
- WITH CONTROL SIGNAL LEAD DISCONNECTED,THE FAN WILL SPIN AT MAXIMUM SPEED.

12. SPEED VS PWM CONTROL SIGNAL:

(AT 25°C, RATED VOLTAGE & PWM SIGNAL AS FOLLOW)

DUTY CYCLE (%)	SPEED R.P.M.	CURRENT (A) TYP.
100	3400±10%	0.23
0~20	1200±300	0.03

* PWM SIGNAL
PWM FREQUENCY = 25KHz

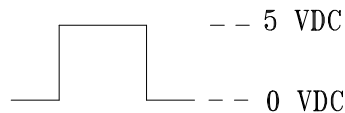

- MIN. START DUTY CYCLE : 20%.
WHEN DUTY CYCLE IS SET FOR MORE THAN 20%, THE FAN WILL BE ABLE TO START FROM A DEAD STOP.

13. PWM CONTROL LEAD WIRE INPUT IMPEDANCE:

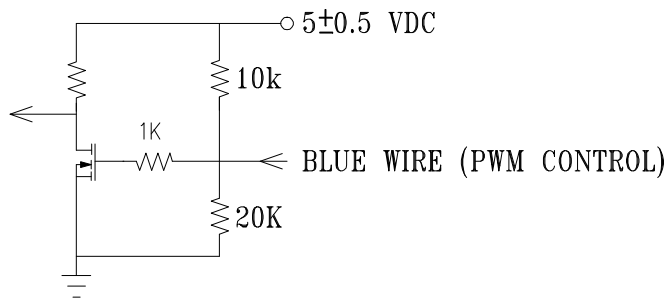



Application Notice

- 1. Delta will not guarantee the performance of the products if the application condition falls outside the parameters set forth in the specification.**
- 2. A written request should be submitted to Delta prior to approval if deviation from this specification is required.**
- 3. Please exercise caution when handling fans. Damage may be caused when pressure is applied to the impeller, if the fans are handled by the lead wires, or if the fan was hard-dropped to the production floor.**
- 4. Except as pertains to some special designs, there is no guarantee that the products will be free from any such safety problems or failures as caused by the introduction of powder, droplets of water or encroachment of insect into the hub.**
- 5. The above-mentioned conditions are representative of some unique examples and viewed as the first point of reference prior to all other information.**
- 6. It is very important to establish the correct polarity before connecting the fan to the power source. Positive (+) and Negative (-). Damage may be caused to the fans if connection is with reverse polarity, if there is no foolproof method to protect against such error specifically mentioned in this spec.**
- 7. Delta fans without special protection are not suitable where any corrosive fluids are introduced to their environment.**
- 8. Please ensure all fans are stored according to the storage temperature limits specified. Do not store fans in a high humidity environment. We highly recommend performance testing is conducted before shipping, if the fans have been stored over 6 months.**
- 9. Not all fans are provided with the Lock Rotor Protection feature. If you impair the rotation of the impeller for the fans that do not have this function, the performance of those fans will lead to failure.**
- 10. Please be cautious when mounting the fan. Incorrect mounting of fans may cause excess resonance, vibration and subsequent noise.**
- 11. It is important to consider safety when testing the fans. A suitable fan guard should be fitted to the fan to guard against any potential for personal injury.**
- 12. Except where specifically stated, all tests are carried out at room (ambient) temperature and relative humidity conditions of 25°C, 65% RH. The test value is only for fan performance itself.**
- 13. Be certain to connect an “4.7µF or greater” capacitor to the fan externally when the application calls for using multiple fans in parallel, to avoid any unstable power.**



GPWV2.E132003 Fans, Electric - Component

[Page Bottom](#)

Fans, Electric - Component

[See General Information for Fans, Electric - Component](#)**DELTA ELECTRONICS INC**

E132003

252 SHANG YING RD
KUEI SHAN
TAOYUAN HSIEN, 333 TAIWAN

DC fans, Model AFB followed by 0405, followed by HA, HHA, LA or MA, followed by (Y), where (Y) may be xxxxx, where x may be A through Z, 0 through 9, "-" or blank; Model AFB followed by 0505, followed by HB, LB or MB, followed by (Y), where (Y) may be xxxxx, where x may be A through Z, 0 through 9, "-" or blank; Model AFB followed by 0512, followed by HB, HHB, LB or MB, followed by (Y), where (Y) may be xxxxx, where x may be A through Z, 0 through 9, "-" or blank; Model AFB followed by 0605, followed by H, L or M, followed by R00, R05, RR0 or RR05, followed by (Y), where (Y) may be xxxxx, where x may be A through Z, 0 through 9, "-" or blank; Model AFB followed by 0805, followed by H, L or M, followed by (Y); Model AFB followed by 0612, 0624, followed by EH, SH, VH, followed by (Y); Model AFB0612LB followed by (Y), where (Y) may be xxxxx, where x may be A through Z, 0 through 9, "-" or blank; Model AFB followed by 0612, 0624, 0812, 0824, 0912 or 0924, followed by H, HB, HH, HHB, L, LB, LLB, M, MB, SHB or VHB, followed by (Y), where (Y) may be xxxxx, where x may be A through Z, 0 through 9, "-" or blank; Models ASB0412MA, ASB0412LA, ASB0405MA followed by (Y); Model ASB followed by 0405, 0412, followed by HA, HHA, LA or MA, followed by (Y), where (Y) may be xxxxx, where x may be A through Z, 0 through 9, "-" or blank; Model ASB followed by 0505, followed by HB, LB or MB, followed by (Y), where (Y) may be xxxxx, where x may be A through Z, 0 through 9, "-" or blank; Model ASB followed by 0512, 0524, followed by HB, HHB, LB or MB, followed by (Y), where (Y) may be xxxxx, where x may be A through Z, 0 through 9, "-" or blank; Model ASB followed by 0812, 0824, followed by HB, HHB, LB, LLB, MB, SHB or VHB, followed by (Y), where (Y) may be xxxxx, where x may be A through Z, 0 through 9, "-" or blank; Model ASB followed by 0612 or 0624, followed by H, HH, L or M, followed by (Y), where (Y) may be xxxxx, where x may be A through Z, 0 through 9, "-" or blank; Model ASB followed by 0812, followed by L or M, followed by (Y); Model ASB followed by 0912 or 0924, followed by H, L or M, followed by (Y), where (Y) may be xxxxx, where x may be A through Z, 0 through 9, "-" or blank; Model AUB followed by 0505, 0512 or 0524, followed by HB, HHB, LB or MB, followed by (Y), where (Y) may be xxxxx, where x may be A through Z, 0 through 9, "-" or blank; Model AUB followed by 0612, 0624, followed by H, HH, L or M, followed by (Y), where (Y) may be xxxxx, where x may be A through Z, 0 through 9, "-" or blank; Model AUB followed by 0912, 0924, followed by H, HH, L, M or VH, followed by (Y), where (Y) may be xxxxx, where x may be A through Z, 0 through 9, "-" or blank; Model AUB followed by 0612 or 0624, followed by L, M, H or HH, followed by (Y), where (Y) may be xxxxx, where x may be A through Z, 0 through 9, "-" or blank; Model AUB followed by 0812 or 0824, followed by HB, HHB, LB, LLB, MB, SHB or VHB, followed by (Y), where (Y) may be xxxxx, where x may be A through Z, 0 through 9, "-" or blank; Model AUB followed by 0924, followed by L, M, H, HH or VH, followed by (Y), where (Y) may be xxxxx, where x may be A through Z, 0 through 9, "-" or blank; Model BFB followed by 1212, followed by H, HH, L, LL, M or VH, followed by (Y), where (Y) may be xxxxx, where x may be A through Z, 0 through 9, "-" or blank; Model BFB followed by 1224, followed by H, HH, L, LL, M or VH, followed by (Y), where (Y) may be xxxxx, where x may be A through Z, 0 through 9, "-" or blank; Model BFB followed by 1248, followed by H, HH, L, LL, M, followed by (Y), where (Y) may be xxxxx, where x may be A through Z, 0 through 9, "-" or blank; Model BFC followed by 1012, followed by A, B or C, followed by (Y), where (Y) may be xxxxx, where x may be A through Z, 0 through 9, "-" or blank; Model DFB followed by 0405 or 0412, followed by H, L, LL, M, followed by (Y), where (Y) may be xxxxx, where x may be A through Z, 0 through 9, "-" or blank; Model DFB followed by 0612, 0812, 0912, 0824 or 0924 followed by H, L or M, followed by (Y), where (Y) may be xxxxx, where x may be A through Z, 0 through 9, "-" or blank; Model DFB followed by 0612, 0812, 0824, 0912 or 0924, followed by HH, followed by (Y), where (Y) may be xxxxx, where x may be A through Z, 0 through 9, "-" or blank; Model DFB followed by 0424, followed by H, L, LL, M, followed by (Y), where (Y) may be xxxxx, where x may be A through Z, 0 through 9, "-" or blank; Model DFB followed by 0612, 0624, followed by H, HH, L or M, followed by (Y), where (Y) may be xxxxx, where x may be A through Z, 0 through 9, "-" or blank; Model DFC followed by 0612, 0812 or 0912, followed by "A" or "B", followed by (Y), where (Y) may be xxxxx, where x may be A through Z, 0 through 9, "-" or blank; Model DFD followed by 0612 or 0624, followed by H, HH, L or M, followed by (Y), where (Y) may be xxxxx, where x may be A through Z, 0 through 9, "-" or blank; Model SB followed by 0412, followed by H, L, LL or M, followed by (Y), where (Y) may be xxxxx, where x may be A through Z, 0 through 9, "-" or blank; Model SB followed by 0612, 0624, followed by HH, followed by (Y), where (Y) may be xxxxx, where x may be A through Z, 0 through 9, "-" or blank; Model SB followed by 0612, 0624, 0812, 0824, followed by H, L or M, followed by (Y), where (Y) may be xxxxx, where x may be A through Z, 0 through 9, "-" or blank; Model SB followed by 0612, 0624, followed by HD, LD or MD, followed by (Y), where (Y) may be xxxxx, where x may be A through Z, 0 through 9, "-" or blank; Model SB followed by 0812, 0824, followed by HH, followed by (Y), where (Y) may be xxxxx, where x may be A through Z, 0 through 9, "-" or blank; Model SB followed by 0812, followed by MSA or MSG, followed by (Y), where (Y) may be xxxxx, where x may be A through Z, 0 through 9, "-" or blank; Model AFC0612D(Y) where (Y) may be A through Z, 0 through 9, "-" or blank; Models AFB0612DH-8G33(Y), E47199(Y), E47159(Y), DTC-CDA(Y), DTC-CDC(Y), FFR1212DHE(Y), FFR0812DHE(Y), KFB0612HD-8K16(Y), BFB0712HB-8A97(Y), KUC1012D(Y) series, where (Y) may be xxxxx, where x may be A through Z, 0 through 9, "-" or blank; Models TFA1424AG(Y), TFA1448(X)G(Y), TFA1448AGL(Y) series, where (X) may be A, B or C, (Y) may be xxxxx, where x may be A through Z, 0 through 9, "-" or blank

Model AFB followed by 02505, followed by HA, HHA, LA or MA, followed by (Y), where (Y) may be xxxxx, where x may be A through Z, 0 through 9, "-" or blank; Model AFB followed by 02512, followed by HA, HHA, LA or MA, followed by (Y), where (Y) may be xxxxx, where x may be A through Z, 0 through 9, "-" or blank; Model AFB followed by 0305, followed by -HA, -LA, -LLA, MA, followed by (Y), where (Y) may be xxxxx, where x may be A through Z, 0 through 9, "-" or blank; Model AFB followed by 0312, followed by -HA, LA, LLA, MA, followed by (Y), where (Y) may be xxxxx, where x may be A through Z, 0 through 9, "-" or blank; Model AFB followed by 03505, followed by HA, LA, MA, followed by (Y), where (Y) may be xxxxx, where x may be A through Z, 0 through 9, "-" or blank; Model AFB followed by 0405, followed by HD, LD or MD, followed by (Y), where (Y) may be xxxxx, where x may be A through Z, 0 through 9, "-" or blank; Model AFB followed by 03512, followed by LA, MA or HA, followed by (Y), where (Y) may be xxxxx, where x may be A through Z, 0 through 9, "-" or blank; Model AFB followed by 0405, 0412 or 0424, followed by HD, HHD, LD, MD, followed by (Y), where (Y) may be xxxxx, where x may be A through Z, 0 through 9, "-" or blank; Model AFB followed by 0412 or 0424, followed by HD, HHD, LD or MD, followed by (Y), where (Y) may be xxxxx, where x may be A through Z, 0 through 9, "-" or blank; Model AFB followed by 0505, 0512, followed by HA, LA or MA, followed by (Y), where (Y) may be xxxxx, where x may be A through Z, 0 through 9, "-" or blank; Model AFB followed by 0524, followed by HB, HHB, LB or MB, followed by (Y), where (Y) may be xxxxx, where x may be A through Z, 0 through 9, "-" or blank; Model AFB followed by 0605, followed by HB, HHB, LB, LLD, MB, followed by (Y), where (Y) may be xxxxx, where x may be A through Z, 0 through 9, "-" or blank; Model AFB followed by 0605, followed by LLD, followed by (Y), where (Y) may be xxxxx, where x may be A through Z, 0 through 9, "-" or blank; Model AFB followed by 0605, followed by HA, LA or MA, followed by (Y), where (Y) may be xxxxx, where x may be A through Z, 0 through 9, "-" or blank; Model AFB followed by 0612, followed by HA, HB, HHB, LA, MA or MB, followed by (Y), where (Y) may be xxxxx, where x may be A through Z, 0 through 9, "-" or blank; Model AFB followed by 0612 or 0624, followed by HD, HHD, LB, LD, LLD, MD, VHB or VHD, followed by (Y), where (Y) may be xxxxx, where x may be A through Z, 0 through 9, "-" or blank; Model AFB followed by 0624, followed by HB, HHB, LB, MB or VHB, followed by (Y), where (Y) may be xxxxx, where x may be A through Z, 0 through 9, "-" or blank; Model AFB followed by 0648, followed by EH, H, HH, L, M, SH or VH, followed by (Y), where (Y) may be xxxxx, where x may be A through Z, 0 through 9, "-" or blank; Model AFB followed by 0705, followed by H, L or M, followed by (Y), where (Y) may be xxxxx, where x may be A through Z, 0 through 9, "-" or blank; Model AFB followed by 0712 or 0724, followed by H, HA, HH, HHA, L, LA, M, MA, VH or VHA, followed by (Y), where (Y) may be xxxxx, where x may be A through Z, 0 through 9, "-" or blank; Model AFB followed by 0748, followed by H, HH, L or MM, followed by (Y), where (Y) may be xxxxx, where x may be A through Z, 0 through 9, "-" or blank; Model AFB followed by 0812 or 0824, followed by LL, followed by (Y), where (Y) may be xxxxx, where x may be A through Z, 0 through 9, "-" or blank; Model AFB followed by 0812 or 0824, followed by H, L, LL, M, SH or VH, followed by (Y), where (Y) may be xxxxx, where x may be A through Z, 0 through 9, "-" or blank

GPWV2.E132003 - Fans, Electric - Component

Model BDB05405HHB(Y) Series, where (Y) may be xxxxx, where x may be A through Z, 0 through 9, "-" or blank.

Model AFB1548(X)-C(Y) Series, where (X) may be VH, SH or EH, (Y) may be xxxxx, where x may be A through Z, 0 through 9, "-" or blank.

Model BFB1012M-7M2B(Y) Series, where (Y) may be xxxxx, where x may be A through Z, 0 through 9, "-" or blank.

Model GFC0612DS(Y) Series, where (Y) may be xxxxx, where x may be A through Z, 0 through 9, "-" or blank.

Model PFB0812XHE(Y) series, where (Y) may be xxxxx, where x may be A through Z, 0 through 9, "-" or blank.

Model KSB0505HB(Y) series, where (Y) may be xxxxx, where x may be A through Z, 0 through 9, "-" or blank.

Model DSB0405LD(Y) series, where (Y) may be xxxxx, where x may be A through Z, 0 through 9, "-" or blank.

Model BFB1024(Y)H-A(X) series, where (Y) may be V, or H, (X) may be xxxxx, where x may be A through Z, 0 through 9, "-" or blank.

Model AUB0412(X)D(Y) series, where (X) may be H, M or L, (Y) may be xxxxx, where x may be A through Z, 0 through 9, "-" or blank.

Model TAA0412(X)D(Y) series, where (X) may be A, B or C, (Y) may be xxxxx, where x may be A through Z, 0 through 9, "-" or blank.

Models GFC0612DW-A(Y), BUB1012L-8S29(Y), FFR0612DHE(Y), FFR0912DHE(Y), BSB0412HA-SM05(Y) series, where (Y) may be xxxxx, where x may be A through Z, 0 through 9, "-" or blank.

Models EFB1248HHF-6C94(Y), EFB1248HHF-SE(Y), BUB0712HHD-HM(Y) series, where (Y) may be XXXXX, where X may be A through Z, 0 through 9, "-" or blank.

Models AUC0912DF(Y), QUR0912VH(Y), series, where (Y) may be xxxxx, where x may be A through Z, 0 through 9, "-" or blank.

Models KSB0605HC(Y), KSB05105HC(Y), EFB1248HF-8H55(Y), EFB1248HF-SX(Y), FFB0848SH-SX(Y), FFB0848HH-SX(Y), FFB0848HH-7L58(Y), FFB0812VH-HM(Y), AFB0912EHE-SX(Y) series, where (Y) may be xxxxx, where x may be A through Z, 0 through 9, "-" or blank.

Models QUR0812HH(Y), QUR0812VH(Y), QUR0812SH(Y), GFB0412SHS-D(Y), GFB0412EHS-D(Y), GFC0412DS-D(Y), FFB1212SHE(Y), FFB1212EHE(Y) series, where (Y) may be xxxxx, where x may be A through Z, 0 through 9, "-" or blank.

Models BUB0412(X)HD(Y), BFB0712HB-HM(Y), BFB0712HF-8A72(Y), ASB04505(Z)A-A(Y), ASB04512(Z)A-A(Y) series, where (X) may be S or V, (Y) may be XXXXX, where X may be A through Z, 0 through 9, "-" or blank, (Z) may be H, M or L.

Models KSB0705HA-8J02(Y), KSB0705HA-8J04(Y) series, where (Y) may be xxxxx, where x may be A through Z, 0 through 9, "-" or blank.

Models FFB0818UHE-8V2E(Y), 141373-1(Y), 141074-2(Y) series, where (Y) may be xxxxx, where x may be A through Z, 0 through 9, "-" or blank.

Models QFR0824SH(Y), KSB0505HB-8K1C(Y) series, where (Y) may be xxxxx, where x may be A through Z, 0 through 9, "-" or blank.

Models KSB0405HB, KSB0405HB(Y) series, where (Y) may be xxxxx, where x may be A through Z, 0 through 9 or "-".

Models PFC1212DE-8H85(Y), PFC1212DE-SM(Y) series, where (X) may be L, M, H, HH or VH, (Y) may be xxxxx, where x may be A through Z, 0 through 9, "-" or blank.

Models FFB0612DHE-8F58(Y), FFB0612DHE-SM(Y), KSB0305HA(Y), EFB0412(X)D-C(Y) series, where (X) may be L, M, H, HH or VH, (Y) may be xxxxx, where x may be A through Z, 0 through 9, "-" or blank.

Model KFB0405HA-SE(Y) series, where (Y) may be xxxxx, where x may be A through Z, 0 through 9, "-" or blank.

Models **KDB0712HB(Y)**, GFB1212(X)W-A(Y), GFC1212DW-A(Y), AUB0812VH-C(Y), AUB0812VH-8G76(Y), AUB0812HH-C(Y) series, where (X) may be SH, EH or GH, (Y) may be xxxxx, where x may be A through Z, 0 through 9, "-" or blank.

Models GFB0412EHG-D(Y), GFB0412GHG-D(Y), GFC0412DG-D(Y), KSB0505HA-9D1H(Y) series, where (Y) may be xxxxx, where x may be A through Z, 0 through 9, "-" or blank.

Models AFB2848VHW(Y), AFC2848DW(Y), AUC0912D-8L2V(Y), E41997-(Y), E41759-(Y), DTC-DAA(Y), DTC-DAB(Y), KSB06305HA(Y) series, where (Y) may be xxxxx, where x may be A through Z, 0 through 9, "-" or blank.

Models AFB0648EHE(Y), AFC0612D-9B24(Y), AFC0612D-SM00(Y), PFR0912(X)HE(Y), PFR1212(Z)HE(Y) series, where (X) may be D or X, (Y) may be xxxxx, where x may be A through Z, 0 through 9, "-" or blank, (Z) may be U or D.

Models AUB0405(X)D(Y), TDA1348AE(Y), TDA1348AE-8D31(Y), BUB0512(Z)D-A(Y), BFB0512(Z)D-A(Y) series, where (X) may be L, M or H, (Z) may be H, HH, VH or SH, (Y) may be xxxxx, where x may be A through Z, 0 through 9, "-" or blank.

Models TDA1548AG(Y), TDA1748AG(Y), AFB1248DHE-6D21(Y), ASB02512(A)HA-A(Y), FFC0412DN-D(Y), FFB0412(B)HN-D(Y) series, where (A) may be V or H, (B) may be U or E, (Y) may be xxxxx, where x may be A through Z, 0 through 9, "-" or blank.

Models BFB1012UH(Y), BFB1012GH(Y) series, where (Y) may be xxxxx, each x may be A through Z, 0 through 9, "-" or blank.

Models AUC1212DE(Y), AUB1212HHE(Y) series, where (Y) may be xxxxx, where x may be A through Z, 0 through 9, "-" or blank.

EC Declaration of Conformity

Issuer's name and address:

Delta Electronics Inc.
6F, No. 186, Ruey Kuang Road
11491 NEIHU, TAIPEI
TAIWAN

Product:

Fan for building-in, IT-equipment

Type designation:

AFB0612DH-8G33; E47199-XXX; E47159-XXX; DTC-CDAXX;
DTC-CDCXX; FFR1212DHE; FFR0812DHE; KFB0612HD-8K16;
BFB0712HB-8A97; KUC1012D; BUB0412SHD/VHD;
BFB0712HB-HM; BFB0712HF-8A72;
ASB04505LA-A/MA-A/HA-A; ASB04512LA-A/MA-A/HA-A;
PHB1548MG/HG/HHG; PHC1548DG; PHB1748MG/HG/HHG;
PHC1748DG; KFB2248HT/HHT; KFC2248DT;
KSB0705HA-8J02; KSB0705HA-8J04;
PFR0812UHE/DHE/XHE;
AUC0912D-8H79/DTC-AATXX/DTC-AAUXX; AUB0912M-8J29;
FFB0818UHE-8V2E; 141373-1; 141074-2; QFR0824SH;
KSB0505HB-8K1C; FFB0612DHE-SM; FFB0612DHE-8F58;
EFB0412LD-C/MD-C/HD-C/HHD-C/VHD-C; KSB0305HA;
KSB0405HB; KFB0405HA-SE; PFC1212DE-8H85,
PFC1212DE-SM; **KDB0712HB**; GFC1212DW-A;
GFB1212GHW-A/EHW-A/SHW-A; AUB0812VH-C/HH-C;
AUB0812VH-8G76; EFC1748DG; BFB0505MD/HD/HHD/VHD;
TFA1424AG/TFA1424AGL; TFA1448AG/TFA1448AGL;
TFA1448BG/TFA1448CG; FFB0412UHN-C;
BUB0512HD-A/HHD-A/VHD-A/SHD-A;
BFB0512HD-A/HHD-A/VHD-A/SHD-A; AUC1212DE;
AUB1212HHE; PFC0812DE-9C48; BUB0712HH-9F47;
BFB1012M-8M66R; GFB0412SHS/EHS-D, GFC0412DS-D

The designated product is in conformity with the European Directive:

2006/95/EC

"Council Directive on the harmonization of the laws of the Member States relating to electrical equipment designed for use within certain voltage limits".

The technical documentation and full compliance with the standards listed below proves the conformity of the product with the requirements of the above-mentioned EC Directive:

**DIN EN 60950-1:2006 + A11 (VDE 0805 Teil 1 + A11):2009-11; EN 60950-1:2006 + A11:2009-03
IEC 60950-1(ed.2)**

The VDE Testing and Certification Institute (EU Identification No.0366), Merianstr. 28, 63069 Offenbach (Germany), has tested and certified the product.

Last two digits of the year in which the CE marking was affixed:

Certificate No.
File Reference

40026295
1164100-2611-0014 / 143738 / FG13 / S

2011-03-08
(Place, Date)

Jimmy Chen
(Legally binding signature of the issuer)

GUTACHTEN MIT FERTIGUNGSÜBERWACHUNG CERTIFICATE OF CONFORMITY WITH FACTORY SURVEILLANCE

Delta Electronics Inc.
6F, No. 186, Ruey Kuang Road
11491 NEIHU, TAIPEI
TAIWAN

ist berechtigt, für ihr Produkt /
is authorized to use for their product

Einbauventilator für IT-Geräte
Fan for building-in, IT-equipment

die hier abgebildeten markenrechtlich geschützten Zeichen
für die ab Blatt 2 aufgeführten Typen zu benutzen /
the legally protected Marks as shown below for the types referred to on page 2 ff.



REG.-Nr. 1764 oder/or



oder/or VDE-REG.-Nr. 1764

REG.-Nr. 1764

Geprüft und zertifiziert nach /
Tested and certified according to

DIN EN 60950-1:2006 + A11 (VDE 0805 Teil 1 + A11):2009-11; EN 60950-1:2006 + A11:2009-03
IEC 60950-1(ed.2)



VDE Prüf- und Zertifizierungsinstitut GmbH
VDE Testing and Certification Institute
Zertifizierungsstelle / Certification

Aktenzeichen: 1164100-2611-0014 / 143738

File ref.:

Ausweis-Nr. 40026295

Blatt 1

Certificate No.

Page

Weitere Bedingungen siehe Rückseite und Folgeblätter /
further conditions see overleaf and following pages

Offenbach, 2009-01-13

(letzte Änderung/updated 2010-12-15)

VDE Zertifikate sind nur gültig bei Veröffentlichung unter:
VDE certificates are valid only when published on:

<http://www.vde.com/zertifikat>
<http://www.vde.com/certificate>

Name und Sitz des Genehmigungs-Inhabers / Name and registered seat of the Certificate holder
Delta Electronics Inc., 6F, No. 186, Ruey Kuang Road, 11491 NEIHU, TAIPEI, TAIWAN

Aktenzeichen / File ref.
1164100-2611-0014 / 143738 / FG13 / S

letzte Änderung / updated Datum / Date
2010-12-15 2009-01-13

Dieses Blatt gilt nur in Verbindung mit Blatt 1 des Gutachtens mit Fertigungsüberwachung Nr. 40026295.
This supplement is only valid in conjunction with page 1 of the Certificate of Conformity with factory surveillance No. 40026295.
endif

Einbauventilator für IT-Geräte
Fan for building-in, IT-equipment

Typ(en) / Type(s):

AFB0612DH-8G33	DC 12V (Appendix No. 01)
E47199-XXX	DC 12V (Appendix No. 01)
E47159-XXX	DC 12V (Appendix No. 01)
DTC-CDAXX	DC 12V (Appendix No. 01)
DTC-CDCXX	DC 12V (Appendix No. 01)
FFR1212DHE	DC 12V (Appendix No. 02)
FFR0812DHE	DC 12V (Appendix No. 03)
KFB0612HD-8K16	DC 12V (Appendix No. 04)
BFB0712HB-8A97	DC 12V (Appendix No. 05)
KUC1012D	DC 12V (Appendix No. 06)
PHB1548MG/HG/HHG	DC 48V (Appendix No. 07)
PHC1548DG	DC 48V (Appendix No. 07)
PHB1748MG/HG/HHG	DC 48V (Appendix No. 07)
PHC1748DG	DC 48V (Appendix No. 07)
KFB2248HT/HHT	DC 48V (Appendix No. 08)
KFC2248DT	DC 48V (Appendix No. 08)
BUB0412SHD/VHD	DC 12V (Appendix No. 09)
BFB0712HB-HM	DC 12V (Appendix No. 10)
BFB0712HF-8A72	DC 12V (Appendix No. 11)
ASB04505LA-A/MA-A/HA-A	DC 5V (Appendix No. 12)
ASB04512LA-A/MA-A/HA-A	DC 12V (Appendix No. 13)
KSB0705HA-8J02	DC 5V (Appendix No. 14)
KSB0705HA-8J04	DC 5V (Appendix No. 14)
PFR0812UHE/DHE/XHE	DC 12V (Appendix No. 15)
AUC0912D-8H79/DTC-AATXX/DTC-AAUXX	DC 12V (Appendix No. 16)
AUB0912M-8J29	DC 12V (Appendix No. 17)
FFB0818UHE-8V2E	DC 18V (Appendix No. 18)
141373-1	DC 18V (Appendix No. 18)
141074-2	DC 18V (Appendix No. 18)
QFR0824SH	DC 24V (Appendix No. 19)
KSB0505HB-8K1C	DC 5V (Appendix No. 20)
FFB0612DHE-SM	DC 12V (Appendix No. 21)
FFB0612DHE-8F58	DC 12V (Appendix No. 21)
EFB0412LD-C/MD-C/HD-C/HHD-C/VHD-C	DC 12V (Appendix No. 22)
KSB0305HA	DC 5V (Appendix No. 23)
KSB0405HB	DC 5V (Appendix No. 24)

Fortsetzung siehe Blatt 3 /
continued on page 3

Name und Sitz des Genehmigungs-Inhabers / Name and registered seat of the Certificate holder
 Delta Electronics Inc., 6F, No. 186, Ruey Kuang Road, 11491 NEIHU, TAIPEI, TAIWAN

Aktenzeichen / File ref.
 1164100-2611-0014 / 143738 / FG13 / S

letzte Änderung / updated Datum / Date
 2010-12-15 2009-01-13

Dieses Blatt gilt nur in Verbindung mit Blatt 1 des Gutachtens mit Fertigungsüberwachung Nr. 40026295.
 This supplement is only valid in conjunction with page 1 of the Certificate of Conformity with factory surveillance No. 40026295.
 endif

KFB0405HA-SE	DC 5V (Appendix No. 25)
PFC1212DE-8H85, PFC1212DE-SMDC	12V (Appendix No. 26)
<u>KDB0712HB</u>	<u>DC 12V (Appendix No. 27)</u>
GFC1212DW-A	DC 12V (Appendix No. 28)
GFB1212GHW-A/EHW-A/SHW-A	DC 12V (Appendix No. 28)
AUB0812VH-C/HH-C	DC 12V (Appendix No. 29)
AUB0812VH-8G76	DC 12V (Appendix No. 29)
EFC1748DG	DC 12V (Appendix No. 29)
BFB0505MD/HD/HHD/VHD	DC 5V (Appendix No. 30)
TFA1424AG/TFA1424AGL	DC 24V (Appendix No. 31)
TFA1448AG/TFA1448AGL	DC 48V (Appendix No. 31)
TFA1448BG/TFA1448CG	DC 48V (Appendix No. 31)
FFB0412UHN-C	DC 12V (Appendix No. 32)
BUB0512HD-A/HHD-A/VHD-A/SHD-A	DC 12V (Appendix No. 33)
BFB0512HD-A/HHD-A/VHD-A/SHD-A	DC 12V (Appendix No. 33)
AUC1212DE	DC 12V (Appendix No. 34)
AUB1212HHE	DC 12V (Appendix No. 34)
PFC0812DE-9C48	DC 12V (Appendix No. 35)
BUB0712HH-9F47	DC 12V (Appendix No. 36)
BFB1012M-8M66R	DC 12V (Appendix No. 37)
GFB0412SHS/EHS-D, GFC0412DS-D	DC 12V (Appendix No. 38)

Zusatz zur Typenbezeichnung Optional - Anhang 0 bis 9 oder A bis Z
 kann hinzugefügt sein für optionale Signal-Ausgänge
Addition for type designation *Optional - Suffix 0 to 9 or A to Z*
 may be added denoting optional signal leads

Nennspannung min. DC 3.3 V - max. DC 48 V (SELV)
Rated voltage

Nennstrom siehe Anlagen / see Appendices
Rated current

Umgebungstemperatur siehe Anlagen / see Appendices
Ambient temperature

Schutzklasse III
Class

Schutzart Einbaulüfter (für IT-Geräte)
Degree of protection *Fan for building-in (for IT equipment)*

Fortsetzung siehe Blatt 4 /
continued on page 4

Name und Sitz des Genehmigungs-Inhabers / Name and registered seat of the Certificate holder
Delta Electronics Inc., 6F, No. 186, Ruey Kuang Road, 11491 NEIHU, TAIPEI, TAIWAN

Aktenzeichen / File ref.
1164100-2611-0014 / 143738 / FG13 / S

letzte Änderung / updated Datum / Date
2010-12-15 2009-01-13

Dieses Blatt gilt nur in Verbindung mit Blatt 1 des Gutachtens mit Fertigungsüberwachung Nr. 40026295.
This supplement is only valid in conjunction with page 1 of the Certificate of Conformity with factory surveillance No. 40026295.
endif

Einbaubedingungen

Beim Einbau des genehmigten Erzeugnisses, der entsprechend der zugehörigen Installationsanleitung zu erfolgen hat, ist darauf zu achten, dass alle Anforderungen gemäss der oben genannten Bestimmung(en) eingehalten sind.

Built-in requirements

For the installation of the certified equipment, which has to be carried out according to the respective installation manual, all requirements of the standard(s) mentioned above have to be fulfilled.

Weitere Angaben
Further information

siehe Anlagen / see Appendices

Dieser Zeichengenehmigungs-Ausweis bildet eine Grundlage für die EG-Konformitätserklärung und CE-Kennzeichnung durch den Hersteller oder dessen Bevollmächtigten und bescheinigt die Konformität mit den grundlegenden Schutzanforderungen der **EG-Niederspannungsrichtlinie 2006/95/EG** mit ihren Änderungen.

*This Marks Approval is a basis for the EC Declaration of Conformity and the CE Marking by the manufacturer or his agent and proves the conformity with the essential safety requirements of the **EC Low-Voltage Directive 2006/95/EC** including amendments.*

VDE Prüf- und Zertifizierungsinstitut GmbH
VDE Testing and Certification Institute
Fachgebiet FG13
Section FG13

VDE Prüf- und Zertifizierungsinstitut Gutachten mit Fertigungsüberwachung

Ausweis-Nr. / Beiblatt /
Certificate No. Supplement
40026295

Name und Sitz des Genehmigungs-Inhabers / Name and registered seat of the Certificate holder
Delta Electronics Inc., 6F, No. 186, Ruey Kuang Road, 11491 NEIHU, TAIPEI, TAIWAN

Aktenzeichen / File ref.
1164100-2611-0014 / 143738 / FG13 / S

letzte Änderung / updated Datum / Date
2010-12-15 2009-01-13

Dieses Beiblatt ist Bestandteil des Gutachtens mit Fertigungsüberwachung Nr. 40026295.
This supplement is part of the Certificate of Conformity with factory surveillance No. 40026295.

Einbauventilator für IT-Geräte Fan for building-in, IT-equipment

Fertigungsstätte(n) Place(s) of manufacture

Referenz/Reference
30013236 Delta Electronics (Thailand)
Public Co., Ltd.
111 Moo 9 Wellgrow Industrial Est. Bangna-Trad Rd.
Tambon Bangwa, Bangpakong
TH-24180 CHACHOENGSAO

Referenz/Reference
30009495 Delta Electronics Components
(DongGuan) Co., Ltd.
HeTianxia High-Tech Industrial Park
523300 SHIJIE TOWN, DONGGUAN CITY
Guangdong
CHINA

Referenz/Reference
30011790 Delta Electronics
(Jiang Su) Ltd.
No. 1688 Jiangxiang East Road
Wujiang Economy Developm. Zone
215200 WUJIANG CITY, SUZHOU CITY
Jiangsu
CHINA

VDE Prüf- und Zertifizierungsinstitut GmbH
VDE Testing and Certification Institute
Fachgebiet FG13
Section FG13



Delta Electronics Corp.

5. MATERIAL RoHS REPORTS

SWRCH18A

SK7

MYLAR

PC

AL1100

C1100

C1020

PBT

INK

PP

PET

SOLDER SN42/BI58

TC-1996

Test Report

No. CANEC1415697307

Date: 26 Sep 2014

Page 1 of 5

SHENZHEN TOP UNITED STEEL CO., LTD.

QIANGXIA INDUSTRIAL ZONE GUANGMING OVERSEAS PASTURE SHENZHEN GUANGDONG
518107, CHINA

The following sample(s) was/were submitted and identified on behalf of the clients as : SWRCH18A

SGS Job No. : CP14-051352 - SZ

Date of Sample Received : 23 Sep 2014

Testing Period : 23 Sep 2014 - 25 Sep 2014

Test Requested : Selected test(s) as requested by client.

Test Method : Please refer to next page(s).

Test Results : Please refer to next page(s).

Conclusion : Based on the performed tests on submitted sample(s), the results of Lead, Mercury, Cadmium, Hexavalent chromium, Polybrominated biphenyls (PBBs), Polybrominated diphenyl ethers (PBDEs) comply with the limits as set by RoHS Directive 2011/65/EU Annex II; recasting 2002/95/EC.

Signed for and on behalf of
SGS-CSTC Ltd.



Almay Gao
Approved Signatory



This document is issued by the Company subject to its General Conditions of Service printed overleaf, available on request or accessible at <http://www.sgs.com/en/Terms-and-Conditions.aspx> and, for electronic format documents, subject to Terms and Conditions for Electronic Documents at <http://www.sgs.com/en/Terms-and-Conditions/Terms-e-Document.aspx>. Attention is drawn to the limitation of liability, indemnification and jurisdiction issues defined therein. Any holder of this document is advised that information contained hereon reflects the Company's findings at the time of its intervention only and within the limits of Client's instructions, if any. The Company's sole responsibility is to its Client and this document does not exonerate parties to a transaction from exercising all their rights and obligations under the transaction documents. This document cannot be reproduced except in full, without prior written approval of the Company. Any unauthorized alteration, forgery or falsification of the content or appearance of this document is unlawful and offenders may be prosecuted to the fullest extent of the law. Unless otherwise stated the results shown in this test report refer only to the sample(s) tested.

Attention: To check the authenticity of testing /inspection report & certificate, please contact us at telephone: (86-755) 8307 1443, or email: CN.Doccheck@sgs.com

SGS-CSTC Standards Technical Services Co., Ltd.
Guangzhou Chemical Laboratory

198 Kezhu Road, Sciencetech Park Guangzhou Economic & Technology Development District, Guangzhou, China 510663 t (86-20) 82155555 f (86-20) 82075113 www.sgsgroup.com.cn
中国·广州·经济技术开发区科学城科珠路198号 邮编: 510663 t (86-20) 82155555 f (86-20) 82075113 e sgs.china@sgs.com

Test Report

No. CANEC1415697307

Date: 26 Sep 2014

Page 2 of 5

Test Results :

Test Part Description :

Specimen No.	SGS Sample ID	Description
SN1	CAN14-156973.007	Dk-grey metal

Remarks :

- (1) 1 mg/kg = 1 ppm = 0.0001%
- (2) MDL = Method Detection Limit
- (3) ND = Not Detected (< MDL)
- (4) "-" = Not Regulated

RoHS Directive 2011/65/EU

- Test Method :
- (1)With reference to IEC 62321-5:2013, determination of Cadmium by ICP-OES.
 - (2)With reference to IEC 62321-5:2013, determination of Lead by ICP-OES.
 - (3)With reference to IEC 62321-4:2013, determination of Mercury by ICP-OES.
 - (4)With reference to IEC 62321:2008, determination of Hexavalent Chromium by spot test / Colorimetric Method using UV-Vis.
 - (5)With reference to IEC 62321:2008, determination of PBBs and PBDEs by GC-MS.

<u>Test Item(s)</u>	<u>Limit</u>	<u>Unit</u>	<u>MDL</u>	<u>007</u>
Cadmium (Cd)	100	mg/kg	2	ND
Lead (Pb)	1,000	mg/kg	2	ND
Mercury (Hg)	1,000	mg/kg	2	ND
Hexavalent Chromium (CrVI)	-	-	◇	Negative
Sum of PBBs	1,000	mg/kg	-	ND
Monobromobiphenyl	-	mg/kg	5	ND
Dibromobiphenyl	-	mg/kg	5	ND
Tribromobiphenyl	-	mg/kg	5	ND
Tetrabromobiphenyl	-	mg/kg	5	ND
Pentabromobiphenyl	-	mg/kg	5	ND
Hexabromobiphenyl	-	mg/kg	5	ND
Heptabromobiphenyl	-	mg/kg	5	ND
Octabromobiphenyl	-	mg/kg	5	ND
Nonabromobiphenyl	-	mg/kg	5	ND
Decabromobiphenyl	-	mg/kg	5	ND
Sum of PBDEs	1,000	mg/kg	-	ND
Monobromodiphenyl ether	-	mg/kg	5	ND



This document is issued by the Company subject to its General Conditions of Service printed overleaf, available on request or accessible at <http://www.sgs.com/en/Terms-and-Conditions.aspx> and, for electronic format documents, subject to Terms and Conditions for Electronic Documents at <http://www.sgs.com/en/Terms-and-Conditions/Terms-e-Documents.aspx>. Attention is drawn to the limitation of liability, indemnification and jurisdiction issues defined therein. Any holder of this document is advised that information contained hereon reflects the Company's findings at the time of its intervention only and within the limits of Client's instructions, if any. The Company's sole responsibility is to its Client and this document does not exonerate parties to a transaction from exercising all their rights and obligations under the transaction documents. This document cannot be reproduced except in full, without prior written approval of the Company. Any unauthorized alteration, forgery or falsification of the content or appearance of this document is unlawful and offenders may be prosecuted to the fullest extent of the law. Unless otherwise stated the results shown in this test report refer only to the sample(s) tested.

Attention: To check the authenticity of testing /inspection report & certificate, please contact us at telephone: (86-755) 8307 1443, or email: CN.Doccheck@sgs.com

198 Kezhu Road, Sciencetech Park Guangzhou Economic & Technology Development District, Guangzhou, China 510663 t (86-20) 82155555 f (86-20) 82075113 www.sgsgroup.com.cn
中国·广州·经济技术开发区科学城科珠路198号 邮编: 510663 t (86-20) 82155555 f (86-20) 82075113 e sgs.china@sgs.com

Test Report

No. CANEC1415697307

Date: 26 Sep 2014

Page 3 of 5

<u>Test Item(s)</u>	<u>Limit</u>	<u>Unit</u>	<u>MDL</u>	<u>007</u>
Dibromodiphenyl ether	-	mg/kg	5	ND
Tribromodiphenyl ether	-	mg/kg	5	ND
Tetrabromodiphenyl ether	-	mg/kg	5	ND
Pentabromodiphenyl ether	-	mg/kg	5	ND
Hexabromodiphenyl ether	-	mg/kg	5	ND
Heptabromodiphenyl ether	-	mg/kg	5	ND
Octabromodiphenyl ether	-	mg/kg	5	ND
Nonabromodiphenyl ether	-	mg/kg	5	ND
Decabromodiphenyl ether	-	mg/kg	5	ND

Notes :

(1) The maximum permissible limit is quoted from the directive 2011/65/EU, Annex II

(2)◇Spot-test:

Negative = Absence of CrVI coating, Positive = Presence of CrVI coating;

(The tested sample should be further verified by boiling-water-extraction method if the spot test result is Negative or cannot be confirmed.)

◇Boiling-water-extraction:

Negative = Absence of CrVI coating

Positive = Presence of CrVI coating; the detected concentration in boiling-water-extraction solution is equal or greater than 0.02 mg/kg with 50 cm² sample surface area.

Information on storage conditions and production date of the tested sample is unavailable and thus results of Cr(VI) represent status of the sample at the time of testing.



This document is issued by the Company subject to its General Conditions of Service printed overleaf, available on request or accessible at <http://www.sgs.com/en/Terms-and-Conditions.aspx> and, for electronic format documents, subject to Terms and Conditions for Electronic Documents at <http://www.sgs.com/en/Terms-and-Conditions/Terms-e-Document.aspx>. Attention is drawn to the limitation of liability, indemnification and jurisdiction issues defined therein. Any holder of this document is advised that information contained hereon reflects the Company's findings at the time of its intervention only and within the limits of Client's instructions, if any. The Company's sole responsibility is to its Client and this document does not exonerate parties to a transaction from exercising all their rights and obligations under the transaction documents. This document cannot be reproduced except in full, without prior written approval of the Company. Any unauthorized alteration, forgery or falsification of the content or appearance of this document is unlawful and offenders may be prosecuted to the fullest extent of the law. Unless otherwise stated the results shown in this test report refer only to the sample(s) tested.

Attention: To check the authenticity of testing /inspection report & certificate, please contact us at telephone: (86-755) 8307 1443, or email: CN.Doccheck@sgs.com

198 Kezhu Road, Sciencetech Park Guangzhou Economic & Technology Development District, Guangzhou, China 510663 t (86-20) 82155555 f (86-20) 82075113 www.sgsgroup.com.cn
 中国·广州·经济技术开发区科学城科珠路198号 邮编: 510663 t (86-20) 82155555 f (86-20) 82075113 e sgs.china@sgs.com

ATTACHMENTS

RoHS Testing Flow Chart

- 1) Name of the person who made testing: Bruce Xiao / Sunny Hu
- 2) Name of the person in charge of testing: Bella Wang / Cutey Yu
- 3) These samples were dissolved totally by pre-conditioning method according to below flow chart (Cr⁶⁺ and PBBs/PBDEs test method excluded).

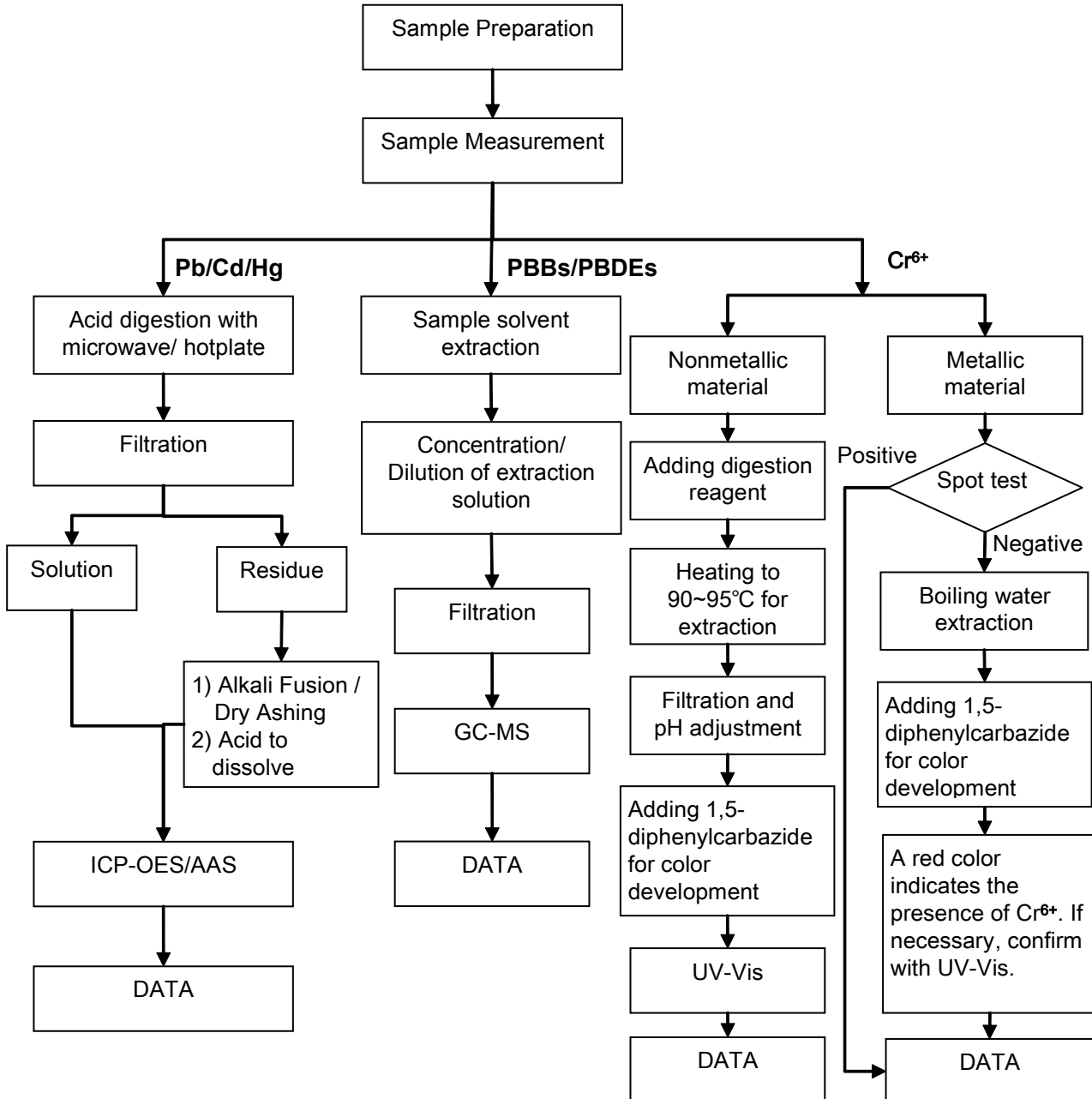

This document is issued by the Company subject to its General Conditions of Service printed overleaf, available on request or accessible at <http://www.sgs.com/en/Terms-and-Conditions.aspx> and, for electronic format documents, subject to Terms and Conditions for Electronic Documents at <http://www.sgs.com/en/Terms-and-Conditions/Terms-e-Documents.aspx>. Attention is drawn to the limitation of liability, indemnification and jurisdiction issues defined therein. Any holder of this document is advised that information contained herein reflects the Company's findings at the time of its intervention only and within the limits of Client's instructions, if any. The Company's sole responsibility is to its Client and this document does not exonerate parties to a transaction from exercising all their rights and obligations under the transaction documents. This document cannot be reproduced except in full, without prior written approval of the Company. Any unauthorized alteration, forgery or falsification of the content or appearance of this document is unlawful and offenders may be prosecuted to the fullest extent of the law. Unless otherwise stated the results shown in this test report refer only to the sample(s) tested.

Attention: To check the authenticity of testing / inspection report & certificate, please contact us at telephone: (86-755) 8307 1443, or email: CN.Doccheck@sgs.com

198 Kezhu Road, Sciencetech Park Guangzhou Economic & Technology Development District, Guangzhou, China 510663 t (86-20) 82155555 f (86-20) 82075113 www.sgsgroup.com.cn
 中国·广州·经济技术开发区科学城科珠路198号 邮编: 510663 t (86-20) 82155555 f (86-20) 82075113 e sgs.china@sgs.com

Sample photo:



SGS authenticate the photo on original report only

*** End of Report ***

測試報告

號碼(No.) : CE/2014/C5207

日期(Date) : 2015/01/05

頁數(Page): 1 of 7

Test Report

煌傑金屬工業股份有限公司/HUANG CHIEH METAL INDUSTRY CO., LTD.



(佛山市南海煌鋼金屬制品有限公司 / FOSHAN NANHAI HUANGGANG METAL PRODUCTS CO., LTD.)

(昆山煌鋼金屬科技有限公司 / KUNSHAN HUANG GANG METAL SCIENCE TECHNOLOGY CO., LTD.)

(昆山濟展金屬科技有限公司 / KUNSHAN JI ZHANG METAL SCIENCE TECHNOLOGY CO., LTD.)

新北市樹林區大安路18之1號 / NO. 18-1, DA-AN ROAD, SHUN-LIN DISTRICT, NEW TAIPEI CITY, TAIWAN

(廣東省佛山市南海區獅山鎮官窯大欖工業區 / DALAN INDUSTRIAL ZONE, GUANYAO SHI-SHAN TOWN, NANHAI DISTRICT, FOSHAN CITY, GUANGDONG PROVINCE, CHINA)

(江蘇省昆山市張浦鎮南港滬光路39號 / NO. 39 HU GUANG ROAD, NANGANG ZHANG PU TOWN, KUNSHAN CITY, JIANGSU PROVINCE CHINA)

以下測試樣品係由申請廠商所提供及確認 (The following sample(s) was/were submitted and identified by/on behalf of the applicant as) :

樣品名稱(Sample Description) : 碳鋼
樣品型號(Style/Item No.) : SK7
收件日期(Sample Receiving Date) : 2014/12/25
測試期間(Testing Period) : 2014/12/25 TO 2015/01/05

測試需求(Test Requested) : 依據客户要求, 參考RoHS 2011/65/EU Annex II 指令進行鎘, 鉛, 汞, 六價鉻, 多溴聯苯, 多溴聯苯醚測試. (As specified by client, with reference to RoHS Directive 2011/65/EU Annex II to determine Cadmium, Lead, Mercury, Cr(VI), PBBs, PBDEs contents in the submitted sample.)

測試方法(Test Method) : 請見下一頁 (Please refer to next pages).

測試結果(Test Results) : 請見下一頁 (Please refer to next pages).

結論(Conclusion) : 根據客戶所提供的樣品, 其鎘, 鉛, 汞, 六價鉻, 多溴聯苯, 多溴聯苯醚的測試結果符合RoHS指令2002/95/EC的更新指令2011/65/EU之要求 (Based on the performed tests on submitted samples, the test result(s) of Cadmium, Lead, Mercury, Cr(VI), PBBs, PBDEs comply with the limits as set by RoHS Directive 2011/65/EU Annex II; recasting 2002/95/EC.)

Troy Chang / Manager - Tech
Signed for and on behalf of
SGS TAIWAN LTD.
Chemical Laboratory - Taipei

測試報告

號碼(No.) : CE/2014/C5207

日期(Date) : 2015/01/05

頁數(Page): 2 of 7

Test Report

煌傑金屬工業股份有限公司 / HUANG CHIEH METAL INDUSTRY CO., LTD.



(佛山市南海煌鋼金屬制品有限公司 / FOSHAN NANHAI HUANGGANG METAL PRODUCTS CO., LTD.)

(昆山煌鋼金屬科技有限公司 / KUNSHAN HUANG GANG METAL SCIENCE TECHNOLOGY CO., LTD.)

(昆山濟展金屬科技有限公司 / KUNSHAN JI ZHANG METAL SCIENCE TECHNOLOGY CO., LTD.)

新北市樹林區大安路18之1號 / NO. 18-1, DA-AN ROAD, SHUN-LIN DISTRICT, NEW TAIPEI CITY, TAIWAN

(廣東省佛山市南海區獅山鎮官窯大欖工業區 / DALAN INDUSTRIAL ZONE, GUANYAO SHI-SHAN TOWN, NANHAI DISTRICT, FOSHAN CITY, GUANGDONG PROVINCE, CHINA)

(江蘇省昆山市張浦鎮南港滬光路39號 / NO. 39 HU GUANG ROAD, NANGANG ZHANG PU TOWN, KUNSHAN CITY, JIANGSU PROVINCE CHINA)

測試結果(Test Results)

測試部位(PART NAME)No.1 : 銀色金屬片 (SILVER COLORED METAL SHEET)

測試項目 (Test Items)	單位 (Unit)	測試方法 (Method)	方法偵測 極限值 (MDL)	結果 (Result)	法規 限值 (Limit)
				No.1	
鎘 / Cadmium (Cd)	mg/kg	參考IEC 62321-5: 2013方法, 以感應耦合電漿原子發射光譜儀檢測. / With reference to IEC 62321-5: 2013 and performed by ICP-AES.	2	n.d.	100
鉛 / Lead (Pb)	mg/kg	參考IEC 62321-5: 2013方法, 以感應耦合電漿原子發射光譜儀檢測. / With reference to IEC 62321-5: 2013 and performed by ICP-AES.	2	n.d.	1000
汞 / Mercury (Hg)	mg/kg	參考IEC 62321-4: 2013方法, 以感應耦合電漿原子發射光譜儀檢測. / With reference to IEC 62321-4: 2013 and performed by ICP-AES.	2	n.d.	1000
六價鉻 / Hexavalent Chromium Cr(VI)	**	參考IEC 62321: 2008方法, 以沸水萃取法檢測. / With reference to IEC 62321: 2008 and performed by Boiling water extraction Method.#	#	Negative	#

This document is issued by the Company subject to its General Conditions of Service printed overleaf, available on request or accessible at <http://www.sgs.com/en/Terms-and-Conditions.aspx> and, for electronic format documents, subject to Terms and Conditions for Electronic Documents at <http://www.sgs.com/en/Terms-and-Conditions/Termse-Document.aspx>. Attention is drawn to the limitation of liability, indemnification and jurisdiction issues defined therein. Any holder of this document is advised that information contained hereon reflects the Company's findings at the time of its intervention only and within the limits of client's instruction, if any. The Company's sole responsibility is to its Client and this document does not exonerate parties to a transaction from exercising all their rights and obligations under the transaction documents. This document cannot be reproduced, except in full, without prior written approval of the Company. Any unauthorized alteration, forgery or falsification of the content or appearance of this document is unlawful and offenders may be prosecuted to the fullest extent of the law. Unless otherwise stated the results shown in this test report refer only to the sample(s) tested.

測試報告

號碼(No.) : CE/2014/C5207

日期(Date) : 2015/01/05

頁數(Page): 3 of 7

Test Report

煌傑金屬工業股份有限公司/HUANG CHIEH METAL INDUSTRY CO., LTD.



(佛山市南海煌鋼金屬制品有限公司 / FOSHAN NANHAI HUANGGANG METAL PRODUCTS CO., LTD.)

(昆山煌鋼金屬科技有限公司 / KUNSHAN HUANG GANG METAL SCIENCE TECHNOLOGY CO., LTD.)

(昆山濟展金屬科技有限公司 / KUNSHAN JI ZHANG METAL SCIENCE TECHNOLOGY CO., LTD.)

新北市樹林區大安路18之1號 / NO. 18-1, DA-AN ROAD, SHUN-LIN DISTRICT, NEW TAIPEI CITY, TAIWAN

(廣東省佛山市南海區獅山鎮官窯大欖工業區 / DALAN INDUSTRIAL ZONE, GUANYAO SHI-SHAN TOWN, NANHAI DISTRICT, FOSHAN CITY, GUANGDONG PROVINCE, CHINA)

(江蘇省昆山市張浦鎮南港滬光路39號 / NO. 39 HU GUANG ROAD, NANGANG ZHANG PU TOWN, KUNSHAN CITY, JIANGSU PROVINCE CHINA)

測試項目 (Test Items)	單位 (Unit)	測試方法 (Method)	方法偵測 極限值 (MDL)	結果 (Result) No.1	法規 限值 (Limit)
多溴聯苯總和 / Sum of PBBs	mg/kg	參考IEC 62321: 2008方法, 以氣相層析 /質譜儀檢測. / With reference to IEC 62321: 2008 and performed by GC/MS.	-	n.d.	1000
一溴聯苯 / Monobromobiphenyl	mg/kg		5	n.d.	-
二溴聯苯 / Dibromobiphenyl	mg/kg		5	n.d.	-
三溴聯苯 / Tribromobiphenyl	mg/kg		5	n.d.	-
四溴聯苯 / Tetrabromobiphenyl	mg/kg		5	n.d.	-
五溴聯苯 / Pentabromobiphenyl	mg/kg		5	n.d.	-
六溴聯苯 / Hexabromobiphenyl	mg/kg		5	n.d.	-
七溴聯苯 / Heptabromobiphenyl	mg/kg		5	n.d.	-
八溴聯苯 / Octabromobiphenyl	mg/kg		5	n.d.	-
九溴聯苯 / Nonabromobiphenyl	mg/kg		5	n.d.	-
十溴聯苯 / Decabromobiphenyl	mg/kg		5	n.d.	-
多溴聯苯醚總和 / Sum of PBDEs	mg/kg		-	n.d.	1000
一溴聯苯醚 / Monobromodiphenyl ether	mg/kg		5	n.d.	-
二溴聯苯醚 / Dibromodiphenyl ether	mg/kg		5	n.d.	-
三溴聯苯醚 / Tribromodiphenyl ether	mg/kg		5	n.d.	-
四溴聯苯醚 / Tetrabromodiphenyl ether	mg/kg		5	n.d.	-
五溴聯苯醚 / Pentabromodiphenyl ether	mg/kg		5	n.d.	-
六溴聯苯醚 / Hexabromodiphenyl ether	mg/kg		5	n.d.	-
七溴聯苯醚 / Heptabromodiphenyl ether	mg/kg		5	n.d.	-
八溴聯苯醚 / Octabromodiphenyl ether	mg/kg		5	n.d.	-
九溴聯苯醚 / Nonabromodiphenyl ether	mg/kg	5	n.d.	-	
十溴聯苯醚 / Decabromodiphenyl ether	mg/kg	5	n.d.	-	

This document is issued by the Company subject to its General Conditions of Service printed overleaf, available on request or accessible at <http://www.sgs.com/en/Terms-and-Conditions.aspx> and, for electronic format documents, subject to Terms and Conditions for Electronic Documents at <http://www.sgs.com/en/Terms-and-Conditions/Termse-Documents.aspx>. Attention is drawn to the limitation of liability, indemnification and jurisdiction issues defined therein. Any holder of this document is advised that information contained hereon reflects the Company's findings at the time of its intervention only and within the limits of client's instruction, if any. The Company's sole responsibility is to its Client and this document does not exonerate parties to a transaction from exercising all their rights and obligations under the transaction documents. This document cannot be reproduced, except in full, without prior written approval of the Company. Any unauthorized alteration, forgery or falsification of the content or appearance of this document is unlawful and offenders may be prosecuted to the fullest extent of the law. Unless otherwise stated the results shown in this test report refer only to the sample(s) tested.

測試報告

號碼(No.) : CE/2014/C5207

日期(Date) : 2015/01/05

頁數(Page): 4 of 7

Test Report

煌傑金屬工業股份有限公司/HUANG CHIEH METAL INDUSTRY CO., LTD.



(佛山市南海煌鋼金屬制品有限公司 / FOSHAN NANHAI HUANGGANG METAL PRODUCTS CO., LTD.)

(昆山煌鋼金屬科技有限公司 / KUNSHAN HUANG GANG METAL SCIENCE TECHNOLOGY CO., LTD.)

(昆山濟展金屬科技有限公司 / KUNSHAN JI ZHANG METAL SCIENCE TECHNOLOGY CO., LTD.)

新北市樹林區大安路18之1號 / NO. 18-1, DA-AN ROAD, SHUN-LIN DISTRICT, NEW TAIPEI CITY, TAIWAN

(廣東省佛山市南海區獅山鎮官窯大欖工業區 / DALAN INDUSTRIAL ZONE, GUANYAO SHI-SHAN TOWN, NANHAI DISTRICT, FOSHAN CITY, GUANGDONG PROVINCE, CHINA)

(江蘇省昆山市張浦鎮南港滬光路39號 / NO. 39 HU GUANG ROAD, NANGANG ZHANG PU TOWN, KUNSHAN CITY, JIANGSU PROVINCE CHINA)

備註(Note) :

1. mg/kg = ppm ; 0.1wt% = 1000ppm
2. n.d. = Not Detected (未檢出)
3. MDL = Method Detection Limit (方法偵測極限值)
4. "-" = Not Regulated (無規格值)
5. ** = Qualitative analysis (No Unit) 定性分析(無單位)
6. # =
 - a. Positive means the presence of CrVI on the tested areas
(Positive表示測試區域偵測到六價鉻)
 - b. Negative means the absence of CrVI on the tested areas
(Negative表示測試區域未偵測到六價鉻)

The detected concentration in boiling-water-extraction solution is equal or greater than 0.02 mg/kg with 50 cm² tested areas. / 該溶液濃度 \geq 0.02 mg/kg with 50 cm² (tested areas)

測試報告

號碼(No.) : CE/2014/C5207

日期(Date) : 2015/01/05

頁數(Page): 5 of 7

Test Report

煌傑金屬工業股份有限公司 / HUANG CHIEH METAL INDUSTRY CO., LTD.



(佛山市南海煌鋼金屬制品有限公司 / FOSHAN NANHAI HUANGGANG METAL PRODUCTS CO., LTD.)

(昆山煌鋼金屬科技有限公司 / KUNSHAN HUANG GANG METAL SCIENCE TECHNOLOGY CO., LTD.)

(昆山濟展金屬科技有限公司 / KUNSHAN JI ZHANG METAL SCIENCE TECHNOLOGY CO., LTD.)

新北市樹林區大安路18之1號 / NO. 18-1, DA-AN ROAD, SHUN-LIN DISTRICT, NEW TAIPEI CITY, TAIWAN

(廣東省佛山市南海區獅山鎮官窯大欖工業區 / DALAN INDUSTRIAL ZONE, GUANYAO SHI-SHAN TOWN, NANHAI DISTRICT, FOSHAN CITY, GUANGDONG PROVINCE, CHINA)

(江蘇省昆山市張浦鎮南港滬光路39號 / NO. 39 HU GUANG ROAD, NANGANG ZHANG PU TOWN, KUNSHAN CITY, JIANGSU PROVINCE CHINA)

- 1) 根據以下的流程圖之條件，樣品已完全溶解。(六價鉻測試方法除外) / These samples were dissolved totally by pre-conditioning method according to below flow chart. (Cr⁶⁺ test method excluded)
- 2) 測試人員：楊登偉 / Name of the person who made measurement: Climbgreat Yang
- 3) 測試負責人：張啓興 / Name of the person in charge of measurement: Troy Chang

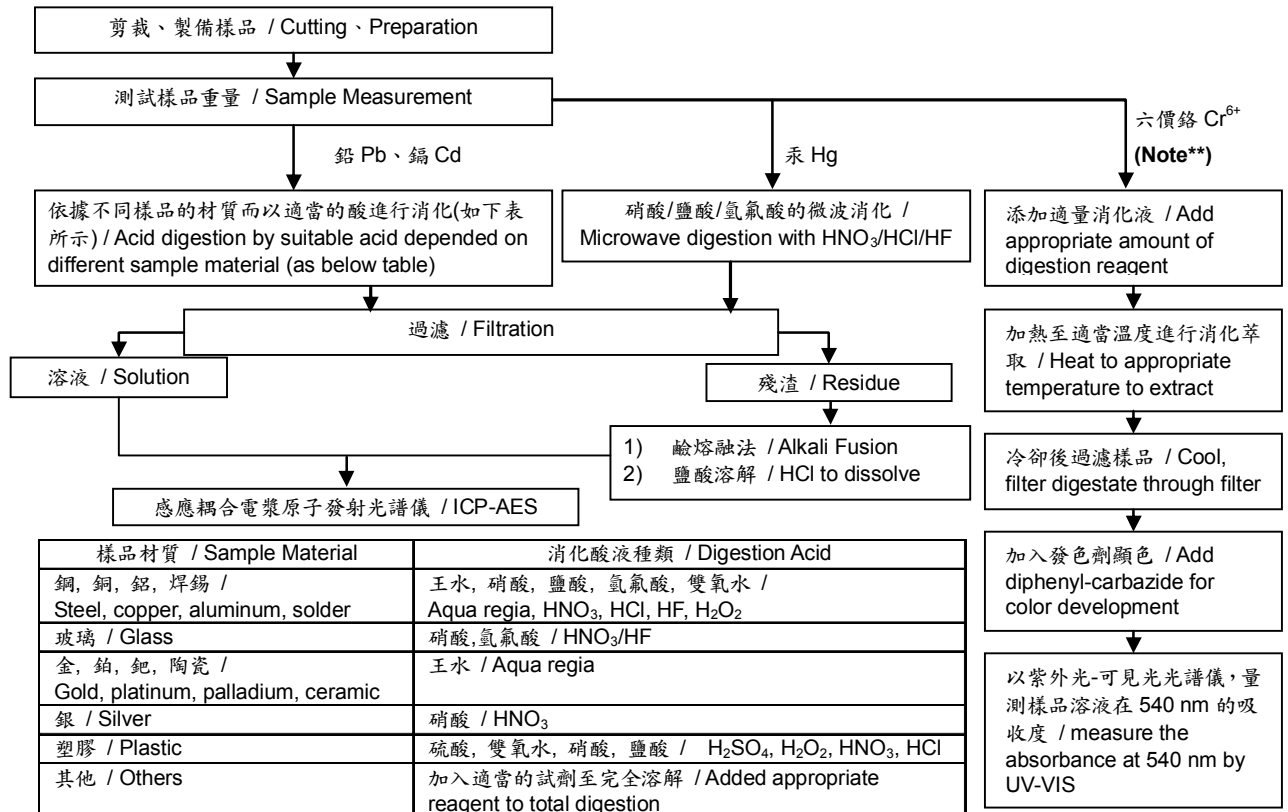

- (1) 針對非金屬材料加入鹼性消化液，加熱至 90~95°C 萃取。 / For non-metallic material, add alkaline digestion reagent and heat to 90~95°C.
- (2) 針對金屬材料加入純水，加熱至沸騰萃取。 / For metallic material, add pure water and heat to boiling.

測試報告

號碼(No.) : CE/2014/C5207

日期(Date) : 2015/01/05

頁數(Page): 6 of 7

Test Report

煌傑金屬工業股份有限公司 / HUANG CHIEH METAL INDUSTRY CO., LTD.



(佛山市南海煌鋼金屬制品有限公司 / FOSHAN NANHAI HUANGGANG METAL PRODUCTS CO., LTD.)

(昆山煌鋼金屬科技有限公司 / KUNSHAN HUANG GANG METAL SCIENCE TECHNOLOGY CO., LTD.)

(昆山濟展金屬科技有限公司 / KUNSHAN JI ZHANG METAL SCIENCE TECHNOLOGY CO., LTD.)

新北市樹林區大安路18之1號 / NO. 18-1, DA-AN ROAD, SHUN-LIN DISTRICT, NEW TAIPEI CITY, TAIWAN

(廣東省佛山市南海區獅山鎮官窯大欖工業區 / DALAN INDUSTRIAL ZONE, GUANYAO SHI-SHAN TOWN, NANHAI DISTRICT, FOSHAN CITY, GUANGDONG PROVINCE, CHINA)

(江蘇省昆山市張浦鎮南港滬光路39號 / NO. 39 HU GUANG ROAD, NANGANG ZHANG PU TOWN, KUNSHAN CITY, JIANGSU PROVINCE CHINA)

多溴聯苯/多溴聯苯醚分析流程圖 / PBB/PBDE analytical FLOW CHART

- 測試人員：翁賜彬 / Name of the person who made measurement: Roman Wong
 - 測試負責人：張啓興 / Name of the person in charge of measurement: Troy Chang
- 初次測試程序 / First testing process —————>
- 選擇性篩檢程序 / Optional screen process>
- 確認程序 / Confirmation process - - ->

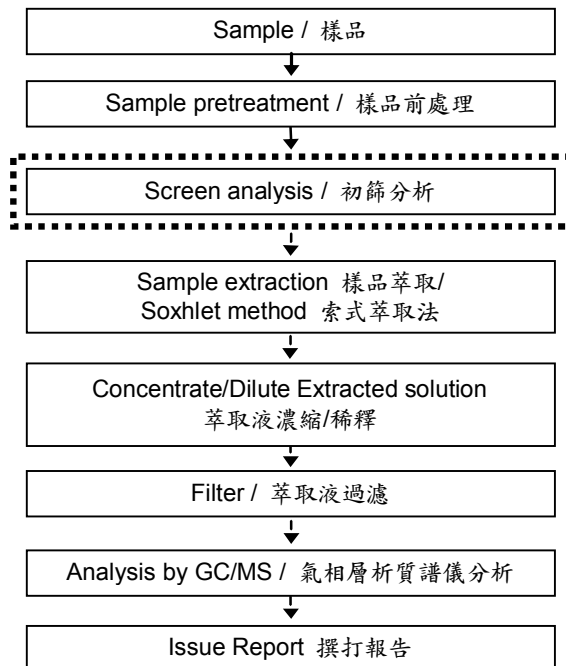

This document is issued by the Company subject to its General Conditions of Service printed overleaf, available on request or accessible at <http://www.sgs.com/en/Terms-and-Conditions.aspx> and, for electronic format documents, subject to Terms and Conditions for Electronic Documents at <http://www.sgs.com/en/Terms-and-Conditions/Termse-Document.aspx>. Attention is drawn to the limitation of liability, indemnification and jurisdiction issues defined therein. Any holder of this document is advised that information contained hereon reflects the Company's findings at the time of its intervention only and within the limits of client's instruction, if any. The Company's sole responsibility is to its Client and this document does not exonerate parties to a transaction from exercising all their rights and obligations under the transaction documents. This document cannot be reproduced, except in full, without prior written approval of the Company. Any unauthorized alteration, forgery or falsification of the content or appearance of this document is unlawful and offenders may be prosecuted to the fullest extent of the law. Unless otherwise stated the results shown in this test report refer only to the sample(s) tested.

測試報告

號碼(No.) : CE/2014/C5207

日期(Date) : 2015/01/05

頁數(Page): 7 of 7

Test Report

煌傑金屬工業股份有限公司 / HUANG CHIEH METAL INDUSTRY CO., LTD.



(佛山市南海煌鋼金屬制品有限公司 / FOSHAN NANHAI HUANGGANG METAL PRODUCTS CO., LTD.)

(昆山煌鋼金屬科技有限公司 / KUNSHAN HUANG GANG METAL SCIENCE TECHNOLOGY CO., LTD.)

(昆山濟展金屬科技有限公司 / KUNSHAN JI ZHANG METAL SCIENCE TECHNOLOGY CO., LTD.)

新北市樹林區大安路18之1號 / NO. 18-1, DA-AN ROAD, SHUN-LIN DISTRICT, NEW TAIPEI CITY, TAIWAN

(廣東省佛山市南海區獅山鎮官窯大欖工業區 / DALAN INDUSTRIAL ZONE, GUANYAO SHI-SHAN TOWN, NANHAI DISTRICT, FOSHAN CITY, GUANGDONG PROVINCE, CHINA)

(江蘇省昆山市張浦鎮南港滬光路39號 / NO. 39 HU GUANG ROAD, NANGANG ZHANG PU TOWN, KUNSHAN CITY, JIANGSU PROVINCE CHINA)

* 照片中如有箭頭標示，則表示為實際檢測之樣品/部位。 *

(The tested sample / part is marked by an arrow if it's shown on the photo.)

CE/2014/C5207

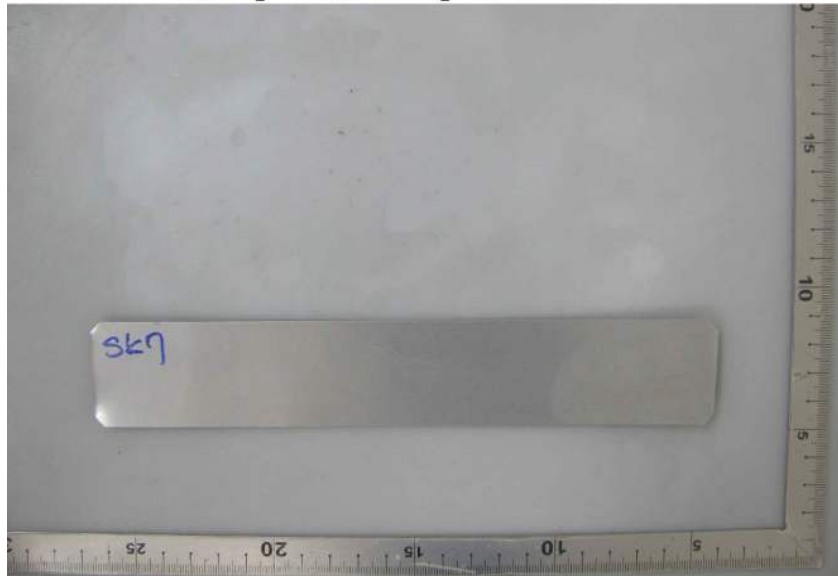

** 報告結尾 (End of Report) **

This document is issued by the Company subject to its General Conditions of Service printed overleaf, available on request or accessible at <http://www.sgs.com/en/Terms-and-Conditions.aspx> and, for electronic format documents, subject to Terms and Conditions for Electronic Documents at <http://www.sgs.com/en/Terms-and-Conditions/Termse-Document.aspx>. Attention is drawn to the limitation of liability, indemnification and jurisdiction issues defined therein. Any holder of this document is advised that information contained hereon reflects the Company's findings at the time of its intervention only and within the limits of client's instruction, if any. The Company's sole responsibility is to its Client and this document does not exonerate parties to a transaction from exercising all their rights and obligations under the transaction documents. This document cannot be reproduced, except in full, without prior written approval of the Company. Any unauthorized alteration, forgery or falsification of the content or appearance of this document is unlawful and offenders may be prosecuted to the fullest extent of the law. Unless otherwise stated the results shown in this test report refer only to the sample(s) tested.

測試報告

Test Report

號碼(No.) : CE/2014/44588 日期(Date) : 2014/04/25 頁數(Page) : 1 of 14

合富工業有限公司

HOPE DISTRIBUTION INC.

台北市基隆路一段111號10樓

10F, NO. 111, SEC. 1, KEELUNG RD., TAIPEI, TAIWAN



以下測試樣品係由申請廠商所提供及確認 (The following sample(s) was/were submitted and identified by/on behalf of the applicant as) :

送樣廠商(Sample Submitted By) : 合富工業有限公司 (HOPE DISTRIBUTION INC.)

樣品名稱(Sample Description) : POLYESTER FILM

樣品型號(Style/Item No.) : S10(S105)

生產或供應廠商
(Manufacturer/Vendor) : TORAY INDUSTRIES INC.

原產國(Country of Origin) : JAPAN

收件日期(Sample Receiving Date) : 2014/04/22

測試期間(Testing Period) : 2014/04/22 TO 2014/04/25

=====
測試結果(Test Results) : 請見下一頁 (Please refer to next pages).

Troy Chang, Manager - Tech
Signed for and on behalf of
SGS TAIWAN LTD.
Chemical Laboratory - Taipei

測試報告

Test Report

號碼(No.) : CE/2014/44588 日期(Date) : 2014/04/25 頁數(Page) : 2 of 14

合富工業有限公司

HOPE DISTRIBUTION INC.

台北市基隆路一段111號10樓

10F, NO. 111, SEC. 1, KEELUNG RD., TAIPEI, TAIWAN



測試結果(Test Results)

測試部位(PART NAME)No.1 : 透明塑膠膜 (TRANSPARENT PLASTIC FILM)

測試項目 (Test Items)	單位 (Unit)	測試方法 (Method)	方法偵測 極限值 (MDL)	結果 (Result)
				No.1
鎘 / Cadmium (Cd)	mg/kg	參考IEC 62321-5: 2013方法, 以感應耦合電漿原子發射光譜儀檢測. / With reference to IEC 62321-5: 2013 and performed by ICP-AES.	2	n.d.
鉛 / Lead (Pb)	mg/kg	參考IEC 62321-5: 2013方法, 以感應耦合電漿原子發射光譜儀檢測. / With reference to IEC 62321-5: 2013 and performed by ICP-AES.	2	n.d.
汞 / Mercury (Hg)	mg/kg	參考IEC 62321-4: 2013方法, 以感應耦合電漿原子發射光譜儀檢測. / With reference to IEC 62321-4: 2013 and performed by ICP-AES.	2	n.d.
六價鉻 / Hexavalent Chromium Cr(VI)	mg/kg	參考IEC 62321: 2008 - Annex C方法, 以UV-VIS檢測. / With reference to IEC 62321: 2008 - Annex C and performed by UV-VIS.	2	n.d.
砷 / Arsenic (As)	mg/kg	參考US EPA 3052方法, 以感應耦合電漿原子發射光譜儀檢測. / With reference to US EPA Method 3052. Analysis was performed by ICP-AES.	2	n.d.
鄰苯二甲酸甲苯基丁酯 / BBP (Benzyl butyl phthalate) (CAS No.: 85-68-7)	%	參考EN 14372, 以氣相層析/質譜儀檢測. / With reference to EN 14372. Analysis was performed by GC/MS.	0.003	n.d.

This document is issued by the Company subject to its General Conditions of Service printed overleaf, available on request or accessible at <http://www.sgs.com/en/Terms-and-Conditions.aspx> and, for electronic format documents, subject to Terms and Conditions for Electronic Documents at <http://www.sgs.com/en/Terms-and-Conditions/Termse-Documents.aspx>. Attention is drawn to the limitation of liability, indemnification and jurisdiction issues defined therein. Any holder of this document is advised that information contained hereon reflects the Company's findings at the time of its intervention only and within the limits of client's instruction, if any. The Company's sole responsibility is to its Client and this document does not exonerate parties to a transaction from exercising all their rights and obligations under the transaction documents. This document cannot be reproduced, except in full, without prior written approval of the Company. Any unauthorized alteration, forgery or falsification of the content or appearance of this document is unlawful and offenders may be prosecuted to the fullest extent of the law. Unless otherwise stated the results shown in this test report refer only to the sample(s) tested.

測試報告

Test Report

號碼(No.) : CE/2014/44588 日期(Date) : 2014/04/25 頁數(Page) : 3 of 14

合富工業有限公司

HOPE DISTRIBUTION INC.

台北市基隆路一段111號10樓

10F, NO. 111, SEC. 1, KEELUNG RD., TAIPEI, TAIWAN



測試項目 (Test Items)	單位 (Unit)	測試方法 (Method)	方法偵測 極限值 (MDL)	結果 (Result)
				No.1
鄰苯二甲酸二(2-乙基己基)酯 / DEHP (Di-(2-ethylhexyl) phthalate) (CAS No.: 117-81-7)	%	參考EN 14372, 以氣相層析/質譜儀檢測。 / With reference to EN 14372. Analysis was performed by GC/MS.	0.003	n.d.
鄰苯二甲酸二異癸酯 / DIDP (Di-isodecyl phthalate) (CAS No.: 26761-40-0; 68515-49-1)	%	參考EN 14372, 以氣相層析/質譜儀檢測。 / With reference to EN 14372. Analysis was performed by GC/MS.	0.01	n.d.
鄰苯二甲酸二異壬酯 / DINP (Di-isononyl phthalate) (CAS No.: 28553-12-0; 68515-48-0)	%	參考EN 14372, 以氣相層析/質譜儀檢測。 / With reference to EN 14372. Analysis was performed by GC/MS.	0.01	n.d.
鄰苯二甲酸二正辛酯 / DNOP (Di-n-octyl phthalate) (CAS No.: 117-84-0)	%	參考EN 14372, 以氣相層析/質譜儀檢測。 / With reference to EN 14372. Analysis was performed by GC/MS.	0.003	n.d.
鄰苯二甲酸二丁酯 / DBP (Dibutyl phthalate) (CAS No.: 84-74-2)	%	參考EN 14372, 以氣相層析/質譜儀檢測。 / With reference to EN 14372. Analysis was performed by GC/MS.	0.003	n.d.
鄰苯二甲酸二異丁酯 / DIBP (Di-isobutyl phthalate) (CAS No.: 84-69-5)	%	參考EN 14372, 以氣相層析/質譜儀檢測。 / With reference to EN 14372. Analysis was performed by GC/MS.	0.003	n.d.
六溴環十二烷及所有主要被辨別出的異構物 / Hexabromocyclododecane (HBCDD) and all major diastereoisomers identified (α -HBCDD, β -HBCDD, γ -HBCDD) (CAS No.: 25637-99-4 and 3194-55-6 (134237-51-7, 134237-50-6, 134237-52-8))	mg/kg	參考IEC 62321: 2008方法, 以氣相層析/質譜儀檢測。 / With reference to IEC 62321: 2008 method. Analysis was performed by GC/MS.	5	n.d.
全氟辛烷磺酸 / Perfluorooctane sulfonates (PFOS-Acid, Metal Salt, Amide)	mg/kg	參考US EPA 3550C: 2007方法, 以液相層析/質譜儀檢測。 / With reference to US EPA 3550C: 2007. Analysis was performed by LC/MS.	10	n.d.

This document is issued by the Company subject to its General Conditions of Service printed overleaf, available on request or accessible at <http://www.sgs.com/en/Terms-and-Conditions.aspx> and, for electronic format documents, subject to Terms and Conditions for Electronic Documents at <http://www.sgs.com/en/Terms-and-Conditions/Termse-Documents.aspx>. Attention is drawn to the limitation of liability, indemnification and jurisdiction issues defined therein. Any holder of this document is advised that information contained hereon reflects the Company's findings at the time of its intervention only and within the limits of client's instruction, if any. The Company's sole responsibility is to its Client and this document does not exonerate parties to a transaction from exercising all their rights and obligations under the transaction documents. This document cannot be reproduced, except in full, without prior written approval of the Company. Any unauthorized alteration, forgery or falsification of the content or appearance of this document is unlawful and offenders may be prosecuted to the fullest extent of the law. Unless otherwise stated the results shown in this test report refer only to the sample(s) tested.

測試報告

Test Report

號碼(No.) : CE/2014/44588 日期(Date) : 2014/04/25 頁數(Page) : 4 of 14

合富工業有限公司

HOPE DISTRIBUTION INC.

台北市基隆路一段111號10樓

10F, NO. 111, SEC. 1, KEELUNG RD., TAIPEI, TAIWAN



測試項目 (Test Items)	單位 (Unit)	測試方法 (Method)	方法偵測 極限值 (MDL)	結果 (Result)
				No.1
全氟辛酸 / PFOA (CAS No.: 335-67-1)	mg/kg	參考US EPA 3550C: 2007方法, 以液相層析/質譜儀檢測. / With reference to US EPA 3550C: 2007. Analysis was performed by LC/MS.	10	n.d.
聚氯乙烯 / PVC	**	以紅外光譜分析及焰色法檢測. / Analysis was performed by FTIR and FLAME Test.	-	Negative
多溴聯苯總和 / Sum of PBBs	mg/kg	參考IEC 62321: 2008 - Annex A方法, 以氣相層析/質譜儀檢測. / With reference to IEC 62321: 2008 - Annex A and performed by GC/MS.	-	n.d.
一溴聯苯 / Monobromobiphenyl			5	n.d.
二溴聯苯 / Dibromobiphenyl			5	n.d.
三溴聯苯 / Tribromobiphenyl			5	n.d.
四溴聯苯 / Tetrabromobiphenyl			5	n.d.
五溴聯苯 / Pentabromobiphenyl			5	n.d.
六溴聯苯 / Hexabromobiphenyl			5	n.d.
七溴聯苯 / Heptabromobiphenyl			5	n.d.
八溴聯苯 / Octabromobiphenyl			5	n.d.
九溴聯苯 / Nonabromobiphenyl			5	n.d.
十溴聯苯 / Decabromobiphenyl			5	n.d.
多溴聯苯醚總和 / Sum of PBDEs			-	n.d.
一溴聯苯醚 / Monobromodiphenyl ether			5	n.d.
二溴聯苯醚 / Dibromodiphenyl ether			5	n.d.
三溴聯苯醚 / Tribromodiphenyl ether			5	n.d.
四溴聯苯醚 / Tetrabromodiphenyl ether			5	n.d.
五溴聯苯醚 / Pentabromodiphenyl ether			5	n.d.
六溴聯苯醚 / Hexabromodiphenyl ether			5	n.d.
七溴聯苯醚 / Heptabromodiphenyl ether			5	n.d.
八溴聯苯醚 / Octabromodiphenyl ether			5	n.d.
九溴聯苯醚 / Nonabromodiphenyl ether	5	n.d.		
十溴聯苯醚 / Decabromodiphenyl ether	5	n.d.		

This document is issued by the Company subject to its General Conditions of Service printed overleaf, available on request or accessible at <http://www.sgs.com/en/Terms-and-Conditions.aspx> and, for electronic format documents, subject to Terms and Conditions for Electronic Documents at <http://www.sgs.com/en/Terms-and-Conditions/Termse-Document.aspx>. Attention is drawn to the limitation of liability, indemnification and jurisdiction issues defined therein. Any holder of this document is advised that information contained hereon reflects the Company's findings at the time of its intervention only and within the limits of client's instruction, if any. The Company's sole responsibility is to its Client and this document does not exonerate parties to a transaction from exercising all their rights and obligations under the transaction documents. This document cannot be reproduced, except in full, without prior written approval of the Company. Any unauthorized alteration, forgery or falsification of the content or appearance of this document is unlawful and offenders may be prosecuted to the fullest extent of the law. Unless otherwise stated the results shown in this test report refer only to the sample(s) tested.

測試報告

Test Report

號碼(No.) : CE/2014/44588 日期(Date) : 2014/04/25 頁數(Page) : 5 of 14

合富工業有限公司

HOPE DISTRIBUTION INC.

台北市基隆路一段111號10樓

10F, NO. 111, SEC. 1, KEELUNG RD., TAIPEI, TAIWAN



測試項目 (Test Items)	單位 (Unit)	測試方法 (Method)	方法偵測 極限值 (MDL)	結果 (Result)
				No.1
鹵素 / Halogen				
鹵素 (氟) / Halogen-Fluorine (F) (CAS No.: 14762-94-8)	mg/kg	參考BS EN 14582:2007, 以離子層析儀分析。 / With reference to BS EN 14582:2007. Analysis was performed by IC.	50	n.d.
鹵素 (氯) / Halogen-Chlorine (Cl) (CAS No.: 22537-15-1)			50	n.d.
鹵素 (溴) / Halogen-Bromine (Br) (CAS No.: 10097-32-2)			50	n.d.
鹵素 (碘) / Halogen-Iodine (I) (CAS No.: 14362-44-8)			50	n.d.

備註(Note) :

1. mg/kg = ppm ; 0.1wt% = 1000ppm
2. n.d. = Not Detected (未檢出)
3. MDL = Method Detection Limit (方法偵測極限值)
4. "-" = Not Regulated (無規格值)
5. ** = Qualitative analysis (No Unit) 定性分析(無單位)
6. Negative = Undetectable 陰性(未偵測到); Positive = Detectable 陽性(已偵測到)

PFOS參考資訊(Reference Information) : 持久性有機污染物 POPs - (EU) 757/2010

PFOS濃度在物質或製備中不得超過0.001%(10ppm), 在半成品、成品或零部件中不得超過0.1%(1000ppm), 在紡織品或塗層材料中不得超過1µg/m²。

(Outlawing PFOS as substances or preparations in concentrations above 0.001% (10ppm), in semi-finished products or articles or parts at a level above 0.1%(1000ppm), in textiles or other coated materials above 1µg/m².)

測試報告

號碼(No.) : CE/2014/44588 日期(Date) : 2014/04/25 頁數(Page) : 6 of 14

Test Report

合富工業有限公司

HOPE DISTRIBUTION INC.

台北市基隆路一段111號10樓

10F, NO. 111, SEC. 1, KEELUNG RD., TAIPEI, TAIWAN



- 1) 根據以下的流程圖之條件，樣品已完全溶解。(六價鉻測試方法除外) / These samples were dissolved totally by pre-conditioning method according to below flow chart. (Cr⁶⁺ test method excluded)
- 2) 測試人員：楊登偉 / Name of the person who made measurement: Climbgreat Yang
- 3) 測試負責人：張啓興 / Name of the person in charge of measurement: Troy Chang

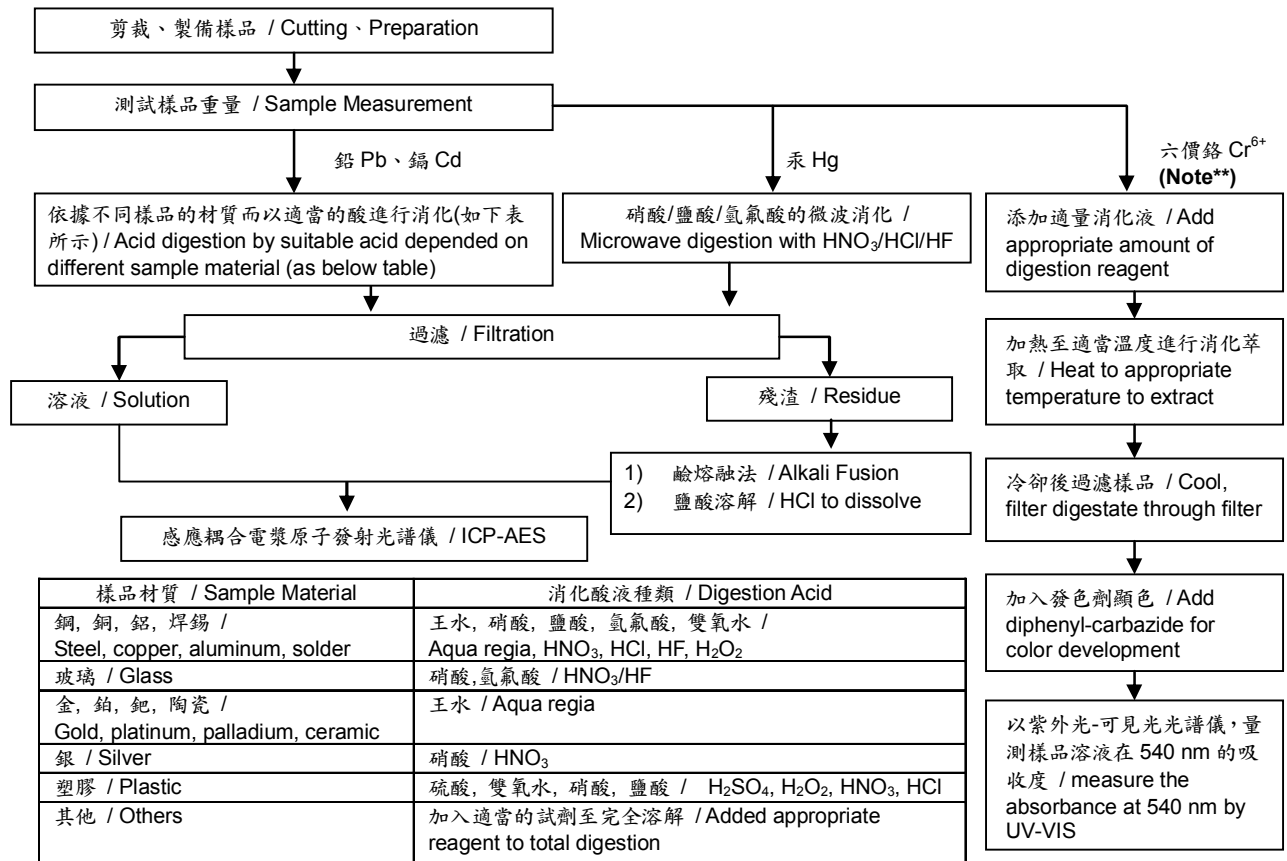

Note (For IEC 62321)**

- (1) 針對非金屬材料加入鹼性消化液，加熱至 90~95°C 萃取。 / For non-metallic material, add alkaline digestion reagent and heat to 90~95°C.
- (2) 針對金屬材料加入純水，加熱至沸騰萃取。 / For metallic material, add pure water and heat to boiling.

測試報告

Test Report

號碼(No.) : CE/2014/44588 日期(Date) : 2014/04/25 頁數(Page) : 7 of 14

合富工業有限公司

HOPE DISTRIBUTION INC.

台北市基隆路一段111號10樓

10F, NO. 111, SEC. 1, KEELUNG RD., TAIPEI, TAIWAN



- 1) 根據以下的流程圖之條件，樣品已完全溶解。 / These samples were dissolved totally by pre-conditioning method according to below flow chart.
- 2) 測試人員：楊登偉 / Name of the person who made measurement: Climbgreat Yang
- 3) 測試負責人：張啓興 / Name of the person in charge of measurement: Troy Chang

元素以 ICP-AES 分析的消化流程圖

(Flow Chart of digestion for the elements analysis performed by ICP-AES)

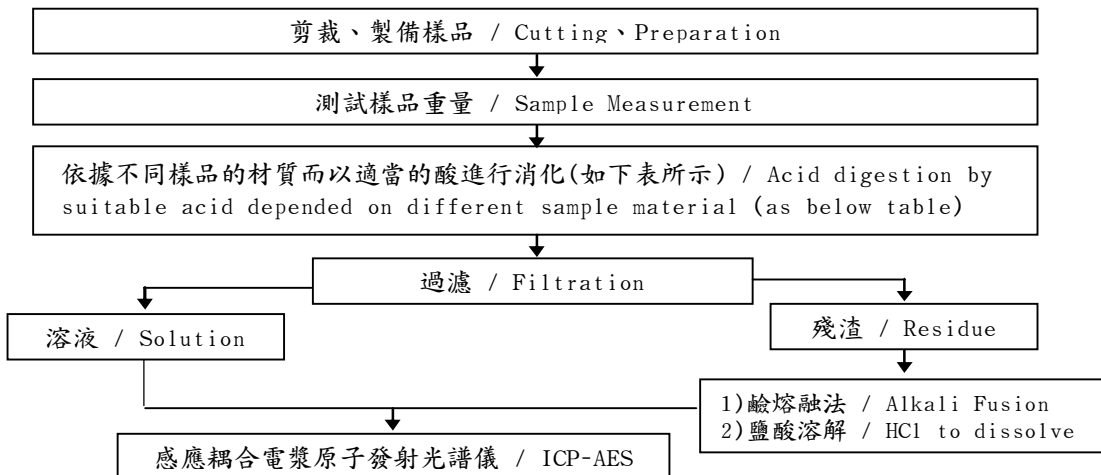

鋼, 銅, 鋁, 焊錫 / Steel, copper, aluminum, solder	王水, 硝酸, 鹽酸, 氫氟酸, 雙氧水 / Aqua regia, HNO ₃ , HCl, HF, H ₂ O ₂
玻璃 / Glass	硝酸, 氫氟酸 / HNO ₃ /HF
金, 鉑, 鈀, 陶瓷 / Gold, platinum, palladium, ceramic	王水 / Aqua regia
銀 / Silver	硝酸 / HNO ₃
塑膠 / Plastic	硫酸, 雙氧水, 硝酸, 鹽酸 / H ₂ SO ₄ , H ₂ O ₂ , HNO ₃ , HCl
其他 / Others	加入適當的試劑至完全溶解 / Added appropriate reagent to total digestion

測試報告

Test Report

號碼(No.) : CE/2014/44588 日期(Date) : 2014/04/25 頁數(Page) : 8 of 14

合富工業有限公司

HOPE DISTRIBUTION INC.

台北市基隆路一段111號10樓

10F, NO. 111, SEC. 1, KEELUNG RD., TAIPEI, TAIWAN



聚氯乙稀物質判定分析流程圖 /

Analysis flow chart for determination of PVC in material

- 測試人員：林建宇 / Name of the person who made measurement: Roy Lin
- 測試負責人：張啓興 / Name of the person in charge of measurement: Troy Chang

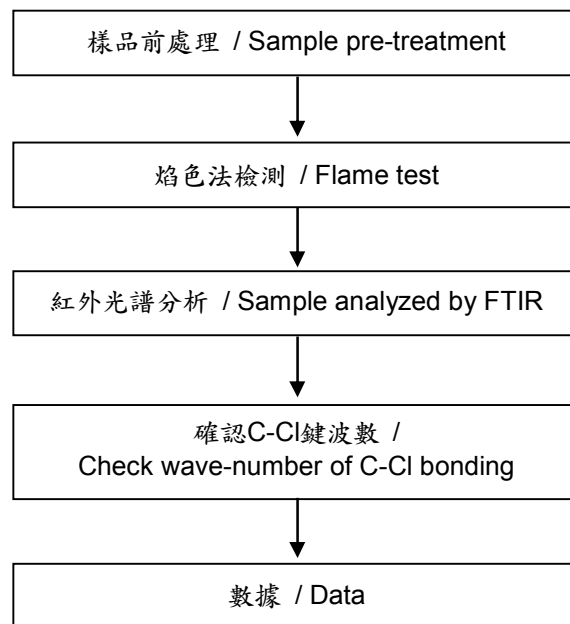

測試報告

Test Report

號碼(No.) : CE/2014/44588 日期(Date) : 2014/04/25 頁數(Page) : 9 of 14

合富工業有限公司

HOPE DISTRIBUTION INC.

台北市基隆路一段111號10樓

10F, NO. 111, SEC. 1, KEELUNG RD., TAIPEI, TAIWAN



全氟辛酸/全氟辛烷磺酸分析流程圖 / PFOA/PFOS analytical flow chart

- 測試人員：翁賜彬 / Name of the person who made measurement: Roman Wong
- 測試負責人：張啓興 / Name of the person in charge of measurement: Troy Chang

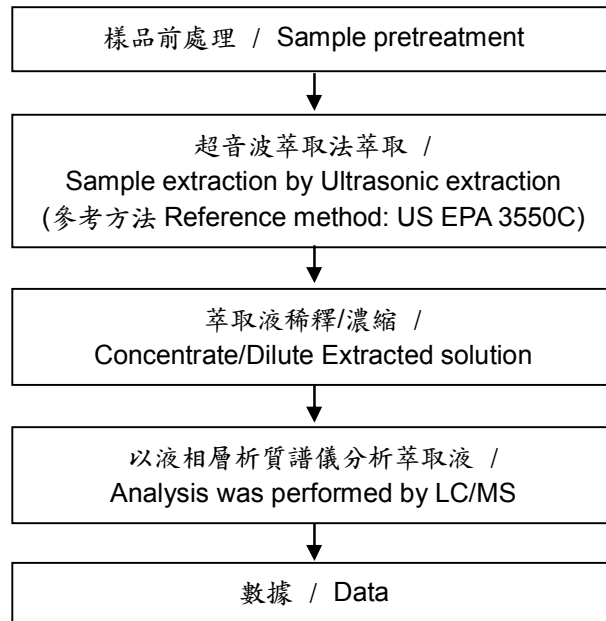

測試報告

Test Report

號碼(No.) : CE/2014/44588 日期(Date) : 2014/04/25 頁數(Page) : 10 of 14

合富工業有限公司

HOPE DISTRIBUTION INC.

台北市基隆路一段111號10樓

10F, NO. 111, SEC. 1, KEELUNG RD., TAIPEI, TAIWAN



六溴環十二烷分析流程圖 / HBCDD analytical flow chart

- 測試人員：翁賜彬 / Name of the person who made measurement: Roman Wong
- 測試負責人：張啓興 / Name of the person in charge of measurement: Troy Chang

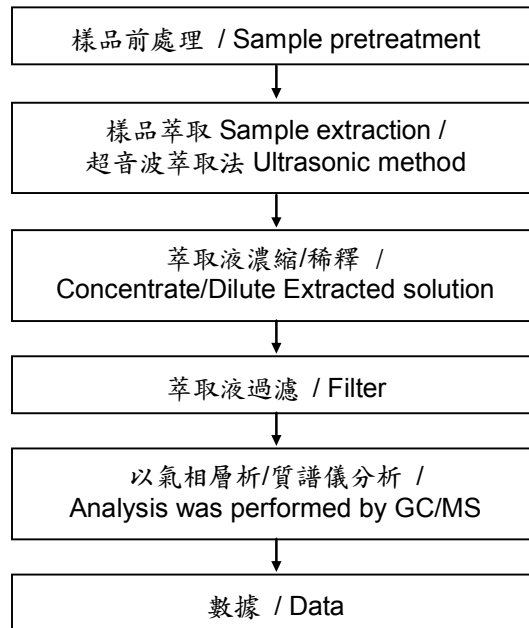

測試報告

Test Report

號碼(No.) : CE/2014/44588 日期(Date) : 2014/04/25 頁數(Page) : 11 of 14

合富工業有限公司

HOPE DISTRIBUTION INC.

台北市基隆路一段111號10樓

10F, NO. 111, SEC. 1, KEELUNG RD., TAIPEI, TAIWAN



可塑劑分析流程圖 / Analytical flow chart of phthalate content

- 測試人員：翁賜彬 / Name of the person who made measurement: Roman Wong
- 測試負責人：張啓興 / Name of the person in charge of measurement: Troy Chang

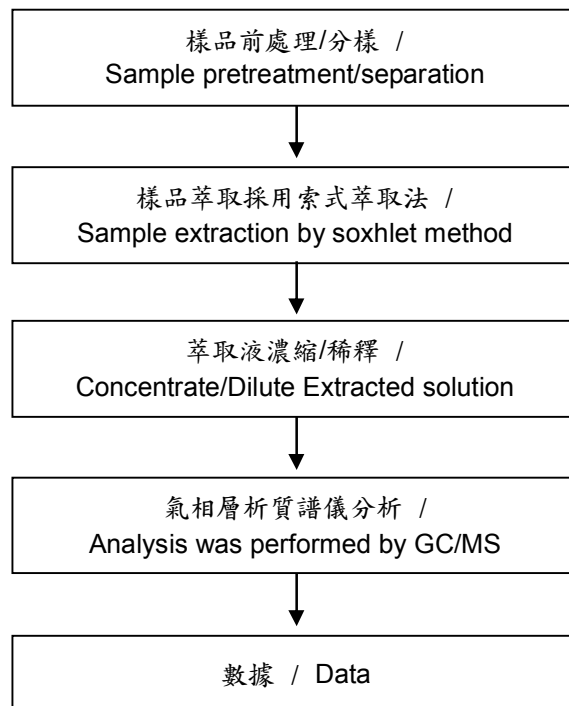

測試報告

Test Report

號碼(No.) : CE/2014/44588 日期(Date) : 2014/04/25 頁數(Page) : 12 of 14

合富工業有限公司

HOPE DISTRIBUTION INC.

台北市基隆路一段111號10樓

10F, NO. 111, SEC. 1, KEELUNG RD., TAIPEI, TAIWAN



鹵素分析流程圖 / Analytical flow chart of halogen content

- 測試人員：陳恩臻 / Name of the person who made measurement: Rita Chen
- 測試負責人：張啓興 / Name of the person in charge of measurement: Troy Chang

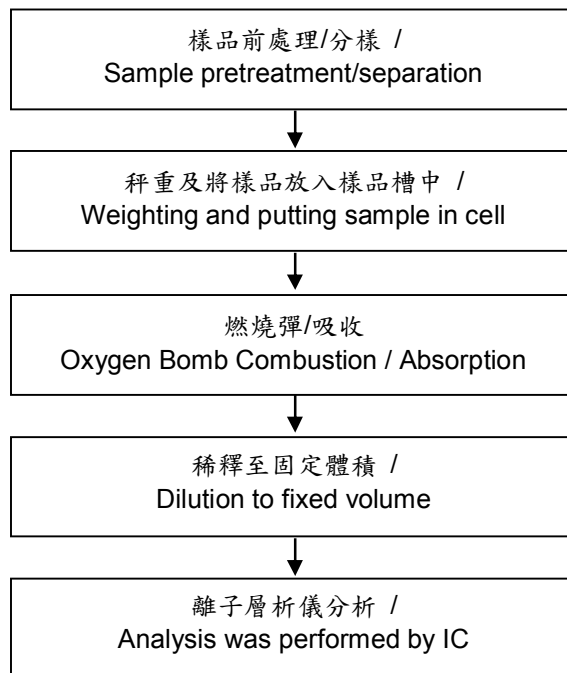

測試報告

Test Report

號碼(No.) : CE/2014/44588 日期(Date) : 2014/04/25 頁數(Page) : 13 of 14

合富工業有限公司

HOPE DISTRIBUTION INC.

台北市基隆路一段111號10樓

10F, NO. 111, SEC. 1, KEELUNG RD., TAIPEI, TAIWAN



多溴聯苯/多溴聯苯醚分析流程圖 / PBB/PBDE analytical FLOW CHART

- 測試人員：翁賜彬 / Name of the person who made measurement: Roman Wong
- 測試負責人：張啓興 / Name of the person in charge of measurement: Troy Chang

初次測試程序 / First testing process —————>

選擇性篩檢程序 / Optional screen process>

確認程序 / Confirmation process - - - ->

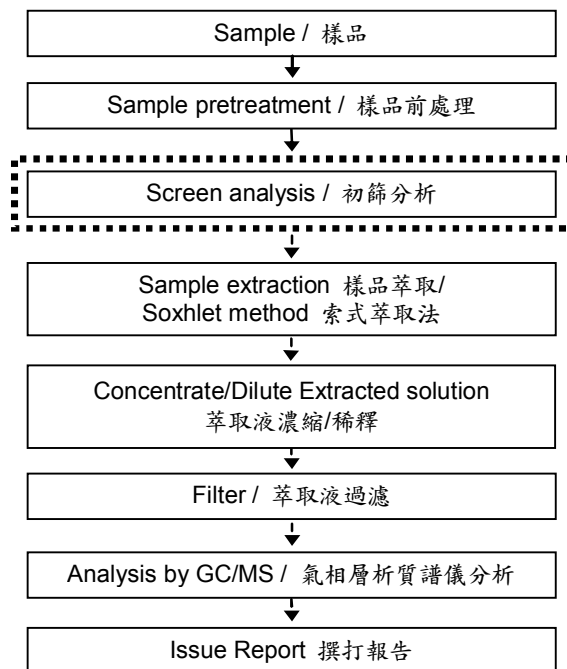

測試報告

Test Report

號碼(No.) : CE/2014/44588 日期(Date) : 2014/04/25 頁數(Page) : 14 of 14

合富工業有限公司

HOPE DISTRIBUTION INC.

台北市基隆路一段111號10樓

10F, NO. 111, SEC. 1, KEELUNG RD., TAIPEI, TAIWAN



* 照片中如有箭頭標示，則表示為實際檢測之樣品/部位。 *
(The tested sample / part is marked by an arrow if it's shown on the photo.)

CE/2014/44588



** 報告結尾 (End of Report) **

Test Report

No. : CE/2014/90077

Date : 2014/09/03

Page: 1 of 6

SABIC TAIWAN HOLDING LIMITED, TAIWAN BRANCH
ROOM B, 7F, NO. 8, MIN SHENG E. RD. SEC. 3, TAIPEI CITY 10480, TAIWAN



The following sample(s) was/were submitted and identified by/on behalf of the applicant as :

Sample Submitted By : SABIC TAIWAN HOLDING LIMITED, TAIWAN BRANCH
Sample Description : PC FILM/SHEET
Style/Item No. : LEXAN* FR700 / FR765
Sample May Cover : LEXAN* FR700 / FR765 / FR700xx / FR765xx
(x MAY COVER 0 ~ 99, ANY LETTERS OR COMBINATION WITH DIGITS AND LETTERS)
Main Substance : POLYCARBONATE
LEXAN* IS A TRADEMARK OF SABIC INNOVATIVE PLASTICS
Sample Receiving Date : 2014/09/01
Testing Period : 2014/09/01 TO 2014/09/03

=====
Test Requested : As specified by client, with reference to RoHS Directive 2011/65/EU Annex II to determine Cadmium, Lead, Mercury, Cr(VI), PBBs, PBDEs contents in the submitted sample.
Test Method : Please refer to next pages.
Test Result(s) : Please refer to next page(s).



Troy Chang, Manager - Tech
Signed for and on Behalf of
SGS TAIWAN LTD.
Chemical Laboratory - Taipei

This document is issued by the Company subject to its General Conditions of Service printed overleaf, available on request or accessible at <http://www.sgs.com/en/Terms-and-Conditions.aspx> and, for electronic format documents, subject to Terms and Conditions for Electronic Documents at <http://www.sgs.com/en/Terms-and-Conditions/Termse-Documents.aspx>. Attention is drawn to the limitation of liability, indemnification and jurisdiction issues defined therein. Any holder of this document is advised that information contained hereon reflects the Company's findings at the time of its intervention only and within the limits of client's instruction, if any. The Company's sole responsibility is to its Client and this document does not exonerate parties to a transaction from exercising all their rights and obligations under the transaction documents. This document cannot be reproduced, except in full, without prior written approval of the Company. Any unauthorized alteration, forgery or falsification of the content or appearance of this document is unlawful and offenders may be prosecuted to the fullest extent of the law. Unless otherwise stated the results shown in this test report refer only to the sample(s) tested.

Test Report

No. : CE/2014/90077

Date : 2014/09/03

Page: 2 of 6

SABIC TAIWAN HOLDING LIMITED, TAIWAN BRANCH
ROOM B, 7F, NO. 8, MIN SHENG E. RD. SEC. 3, TAIPEI CITY 10480, TAIWAN



Test Result(s)

PART NAME No.1 : BLACK SHEET

Test Item(s)	Unit	Method	MDL	Result
				No.1
Cadmium (Cd)	mg/kg	With reference to IEC 62321-5: 2013 and performed by ICP-AES.	2	n.d.
Lead (Pb)	mg/kg	With reference to IEC 62321-5: 2013 and performed by ICP-AES.	2	n.d.
Mercury (Hg)	mg/kg	With reference to IEC 62321-4: 2013 and performed by ICP-AES.	2	n.d.
Hexavalent Chromium Cr(VI)	mg/kg	With reference to IEC 62321: 2008 and performed by UV-VIS.	2	n.d.
Sum of PBBs	mg/kg	With reference to IEC 62321: 2008 and performed by GC/MS.	-	n.d.
Monobromobiphenyl	mg/kg		5	n.d.
Dibromobiphenyl	mg/kg		5	n.d.
Tribromobiphenyl	mg/kg		5	n.d.
Tetrabromobiphenyl	mg/kg		5	n.d.
Pentabromobiphenyl	mg/kg		5	n.d.
Hexabromobiphenyl	mg/kg		5	n.d.
Heptabromobiphenyl	mg/kg		5	n.d.
Octabromobiphenyl	mg/kg		5	n.d.
Nonabromobiphenyl	mg/kg		5	n.d.
Decabromobiphenyl	mg/kg		5	n.d.
Sum of PBDEs	mg/kg		-	n.d.
Monobromodiphenyl ether	mg/kg		5	n.d.
Dibromodiphenyl ether	mg/kg		5	n.d.
Tribromodiphenyl ether	mg/kg		5	n.d.
Tetrabromodiphenyl ether	mg/kg		5	n.d.
Pentabromodiphenyl ether	mg/kg		5	n.d.
Hexabromodiphenyl ether	mg/kg		5	n.d.
Heptabromodiphenyl ether	mg/kg		5	n.d.
Octabromodiphenyl ether	mg/kg		5	n.d.
Nonabromodiphenyl ether	mg/kg	5	n.d.	
Decabromodiphenyl ether	mg/kg	5	n.d.	

This document is issued by the Company subject to its General Conditions of Service printed overleaf, available on request or accessible at <http://www.sgs.com/en/Terms-and-Conditions.aspx> and, for electronic format documents, subject to Terms and Conditions for Electronic Documents at <http://www.sgs.com/en/Terms-and-Conditions/Termse-Document.aspx>. Attention is drawn to the limitation of liability, indemnification and jurisdiction issues defined therein. Any holder of this document is advised that information contained hereon reflects the Company's findings at the time of its intervention only and within the limits of client's instruction, if any. The Company's sole responsibility is to its Client and this document does not exonerate parties to a transaction from exercising all their rights and obligations under the transaction documents. This document cannot be reproduced, except in full, without prior written approval of the Company. Any unauthorized alteration, forgery or falsification of the content or appearance of this document is unlawful and offenders may be prosecuted to the fullest extent of the law. Unless otherwise stated the results shown in this test report refer only to the sample(s) tested.



Test Report

No. : CE/2014/90077

Date : 2014/09/03

Page: 3 of 6

SABIC TAIWAN HOLDING LIMITED, TAIWAN BRANCH
ROOM B, 7F, NO. 8, MIN SHENG E. RD. SEC. 3, TAIPEI CITY 10480, TAIWAN



Note :

1. mg/kg = ppm ; 0.1wt% = 1000ppm
2. n.d. = Not Detected
3. MDL = Method Detection Limit
4. " - " = Not Regulated

This document is issued by the Company subject to its General Conditions of Service printed overleaf, available on request or accessible at <http://www.sgs.com/en/Terms-and-Conditions.aspx> and, for electronic format documents, subject to Terms and Conditions for Electronic Documents at <http://www.sgs.com/en/Terms-and-Conditions/Termse-Documents.aspx>. Attention is drawn to the limitation of liability, indemnification and jurisdiction issues defined therein. Any holder of this document is advised that information contained hereon reflects the Company's findings at the time of its intervention only and within the limits of client's instruction, if any. The Company's sole responsibility is to its Client and this document does not exonerate parties to a transaction from exercising all their rights and obligations under the transaction documents. This document cannot be reproduced, except in full, without prior written approval of the Company. Any unauthorized alteration, forgery or falsification of the content or appearance of this document is unlawful and offenders may be prosecuted to the fullest extent of the law. Unless otherwise stated the results shown in this test report refer only to the sample(s) tested.

Test Report

No. : CE/2014/90077

Date : 2014/09/03

Page: 4 of 6

SABIC TAIWAN HOLDING LIMITED, TAIWAN BRANCH
ROOM B, 7F, NO. 8, MIN SHENG E. RD. SEC. 3, TAIPEI CITY 10480, TAIWAN



- 1) These samples were dissolved totally by pre-conditioning method according to below flow chart.
(Cr⁶⁺ test method excluded)
- 2) Name of the person who made measurement: Climbgreat Yang
- 3) Name of the person in charge of measurement: Troy Chang

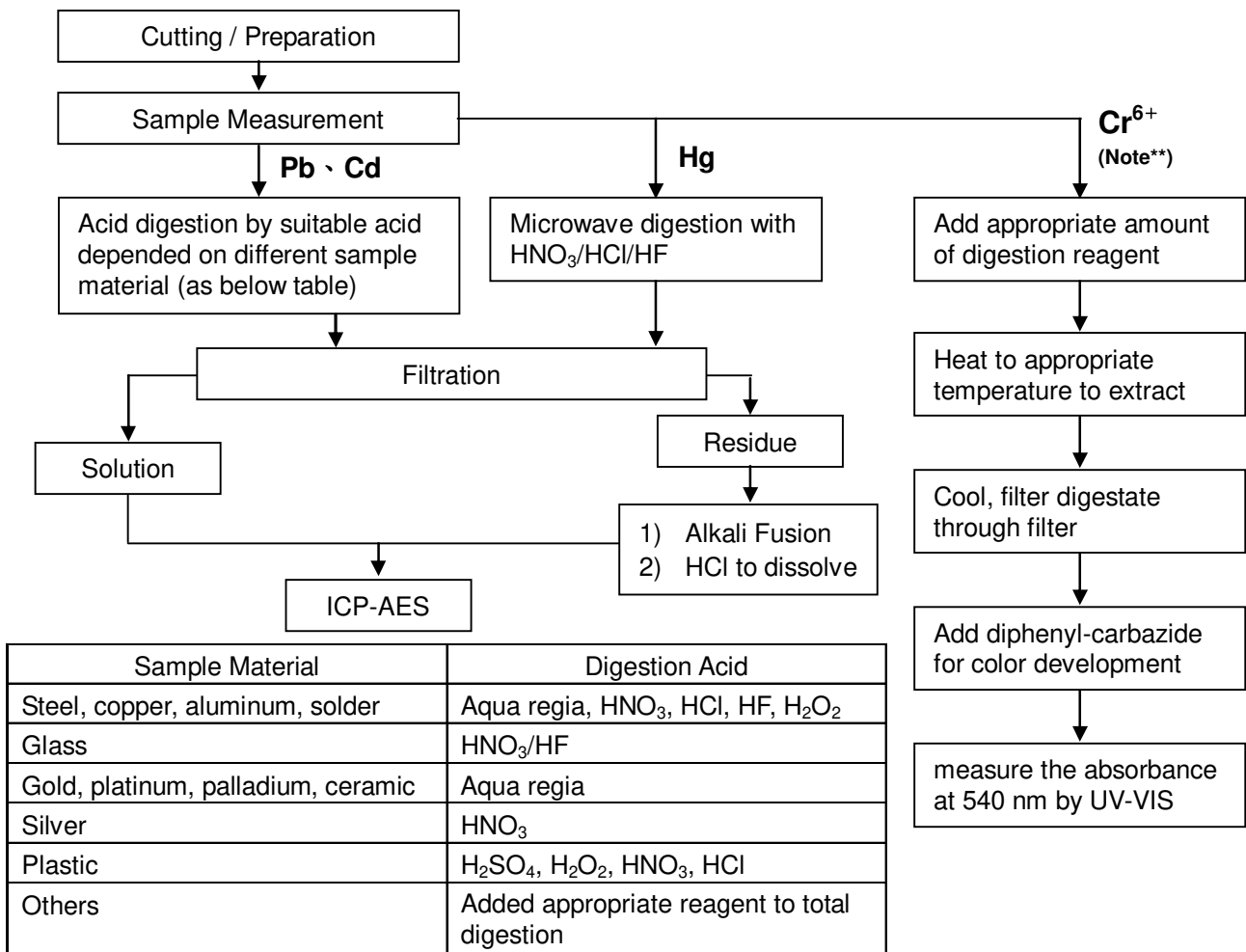

Note :** (1) For non-metallic material, add alkaline digestion reagent and heat to 90~95°C.
(2) For metallic material, add pure water and heat to boiling.

SABIC TAIWAN HOLDING LIMITED, TAIWAN BRANCH
 ROOM B, 7F, NO. 8, MIN SHENG E. RD. SEC. 3, TAIPEI CITY 10480, TAIWAN



PBB/PBDE analytical FLOW CHART

- Name of the person who made measurement: Roman Wong
- Name of the person in charge of measurement: Troy Chang

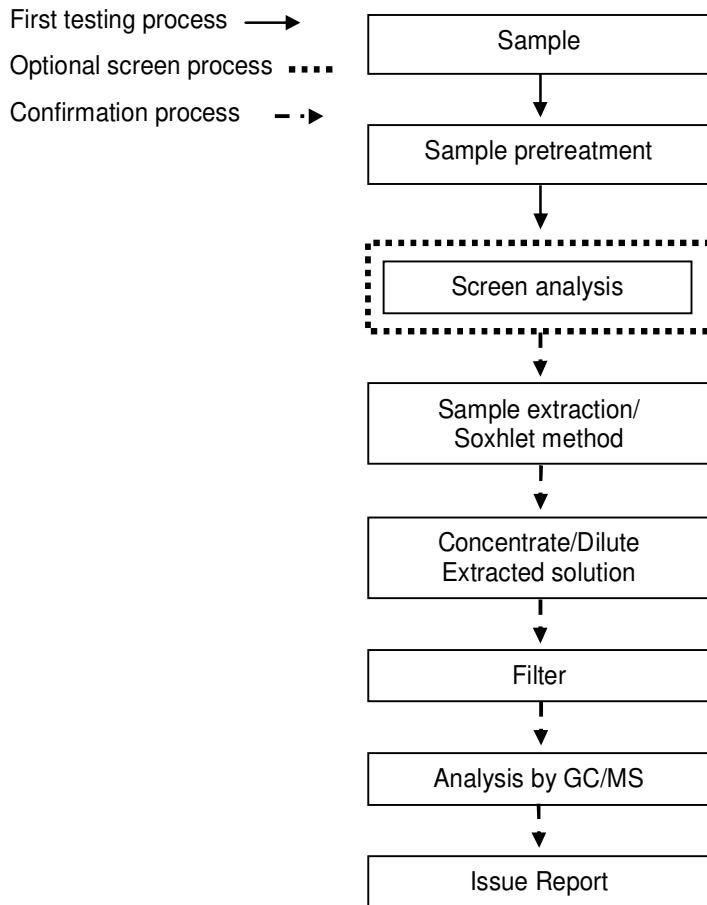

This document is issued by the Company subject to its General Conditions of Service printed overleaf, available on request or accessible at <http://www.sgs.com/en/Terms-and-Conditions.aspx> and, for electronic format documents, subject to Terms and Conditions for Electronic Documents at <http://www.sgs.com/en/Terms-and-Conditions/Termse-Document.aspx>. Attention is drawn to the limitation of liability, indemnification and jurisdiction issues defined therein. Any holder of this document is advised that information contained hereon reflects the Company's findings at the time of its intervention only and within the limits of client's instruction, if any. The Company's sole responsibility is to its Client and this document does not exonerate parties to a transaction from exercising all their rights and obligations under the transaction documents. This document cannot be reproduced, except in full, without prior written approval of the Company. Any unauthorized alteration, forgery or falsification of the content or appearance of this document is unlawful and offenders may be prosecuted to the fullest extent of the law. Unless otherwise stated the results shown in this test report refer only to the sample(s) tested.

Test Report

No. : CE/2014/90077

Date : 2014/09/03

Page: 6 of 6

SABIC TAIWAN HOLDING LIMITED, TAIWAN BRANCH
ROOM B, 7F, NO. 8, MIN SHENG E. RD. SEC. 3, TAIPEI CITY 10480, TAIWAN



* The tested sample / part is marked by an arrow if it's shown on the photo. *

CE/2014/90077



** End of Report **

Test Report

No. XMNML1500101801

Date: 06 Feb 2015

Page 1 of 4

Fujian Nanping Aluminum Sheet & Strip Co.,Ltd
High-tech Zone ,S&I Park ,Nanping,Fujian ,35300,China

The following sample(s) was/were submitted and identified on behalf of the clients as : 1100 alloy

SGS Job No. : XMIN1502000677PC - XM
Specification : 0.18mm
Date of Sample Received : 03 Feb 2015
Testing Period : 03 Feb 2015 - 06 Feb 2015
Test Requested : Selected test(s) as requested by client.
Test Method : Please refer to next page(s).
Test Results : Please refer to next page(s).
Conclusion : Based on the performed tests on submitted sample(s), the results of Lead, Mercury, Cadmium, Hexavalent chromium comply with the limits as set by RoHS Directive 2011/65/EU Annex II; recasting 2002/95/EC.

Signed for and on behalf of
SGS-CSTC Standards Technical Services Co., Ltd. Xiamen Branch

Michael Tso
Approved Signatory



This document is issued by the Company subject to its General Conditions of Service printed overleaf, available on request or accessible at <http://www.sgs.com/en/Terms-and-Conditions.aspx> and, for electronic format documents, subject to Terms and Conditions for Electronic Documents at <http://www.sgs.com/en/Terms-and-Conditions/Terms-e-Document.aspx>. Attention is drawn to the limitation of liability, indemnification and jurisdiction issues defined therein. Any holder of this document is advised that information contained hereon reflects the Company's findings at the time of its intervention only and within the limits of Client's instructions, if any. The Company's sole responsibility is to its Client and this document does not exonerate parties to a transaction from exercising all their rights and obligations under the transaction documents. This document cannot be reproduced except in full, without prior written approval of the Company. Any unauthorized alteration, forgery or falsification of the content or appearance of this document is unlawful and offenders may be prosecuted to the fullest extent of the law. Unless otherwise stated the results shown in this test report refer only to the sample(s) tested.
Attention: To check the authenticity of testing /inspection report & certificate, please contact us at telephone: (86-755) 8307 1443, or email: CN.Doccheck@sgs.com

No. 31 Xianghong Road, Xiang'An Torch Industrial Zone, Xiamen, Fujian Province, China 361101 t (86-592) 5766995 f (86-592) 5766999 www.sgsgroup.com.cn
中国·福建·厦门市火炬(翔安)产业区翔虹路31号 邮编: 361101 t (86-592) 5766995 f (86-592) 5766999 e sgs.china@sgs.com

Test Results :

Test Part Description :

Specimen No.	SGS Sample ID	Description
SN1	XMN15-001018.001	Silver-white metal sheet

Remarks :

- (1) 1 mg/kg = 0.0001%
- (2) MDL = Method Detection Limit
- (3) ND = Not Detected (< MDL)
- (4) "-" = Not Regulated

RoHS Directive 2011/65/EU

Test Method : (1)With reference to IEC 62321-5:2013, determination of Cadmium by ICP-OES.
 (2)With reference to IEC 62321-5:2013, determination of Lead by ICP-OES.
 (3)With reference to IEC 62321-4:2013, determination of Mercury by ICP-OES.
 (4)With reference to IEC 62321:2008, determination of Hexavalent Chromium by spot test / Colorimetric Method using UV-Vis.

Test Item(s)	Limit	Unit	MDL	001
Cadmium (Cd)	100	mg/kg	2	ND
Lead (Pb)	1,000	mg/kg	2	ND
Mercury (Hg)	1,000	mg/kg	2	ND
Hexavalent Chromium (CrVI)	-	-	◇	Negative

Notes :

- (1) The maximum permissible limit is quoted from the directive 2011/65/EU, Annex II
- (2)◇Spot-test:
 Negative = Absence of CrVI coating, Positive = Presence of CrVI coating;
 (The tested sample should be further verified by boiling-water-extraction method if the spot test result is Negative or cannot be confirmed.)
 ◇Boiling-water-extraction:
 Negative = Absence of CrVI coating
 Positive = Presence of CrVI coating; the detected concentration in boiling-water-extraction solution is equal or greater than 0.02 mg/kg with 50 cm2 sample surface area.
 Information on storage conditions and production date of the tested sample is unavailable and thus results of Cr(VI) represent status of the sample at the time of testing.



This document is issued by the Company subject to its General Conditions of Service printed overleaf, available on request or accessible at <http://www.sgs.com/en/Terms-and-Conditions.aspx> and, for electronic format documents, subject to Terms and Conditions for Electronic Documents at <http://www.sgs.com/en/Terms-and-Conditions/Terms-e-Documents.aspx>. Attention is drawn to the limitation of liability, indemnification and jurisdiction issues defined therein. Any holder of this document is advised that information contained hereon reflects the Company's findings at the time of its intervention only and within the limits of Client's instructions, if any. The Company's sole responsibility is to its Client and this document does not exonerate parties to a transaction from exercising all their rights and obligations under the transaction documents. This document cannot be reproduced except in full, without prior written approval of the Company. Any unauthorized alteration, forgery or falsification of the content or appearance of this document is unlawful and offenders may be prosecuted to the fullest extent of the law. Unless otherwise stated the results shown in this test report refer only to the sample(s) tested.
 Attention: To check the authenticity of testing /inspection report & certificate, please contact us at telephone: (86-755) 8307 1443, or email: CN.Doccheck@sgs.com

No. 31 Xianghong Road, Xiang'An Torch Industrial Zone, Xiamen, Fujian Province, China 361101 t (86-592) 5766995 f (86-592) 5766999 www.sgsgroup.com.cn
 中国·福建·厦门市火炬(翔安)产业区翔虹路31号 邮编: 361101 t (86-592) 5766995 f (86-592) 5766999 e sgs.china@sgs.com

ATTACHMENTS

RoHS Testing Flow Chart

- 1) Name of the person who made testing: Sunny Lu
- 2) Name of the person in charge of testing: Michael Tso
- 3) These samples were dissolved totally by pre-conditioning method according to below flow chart (Cr6+ test method excluded).

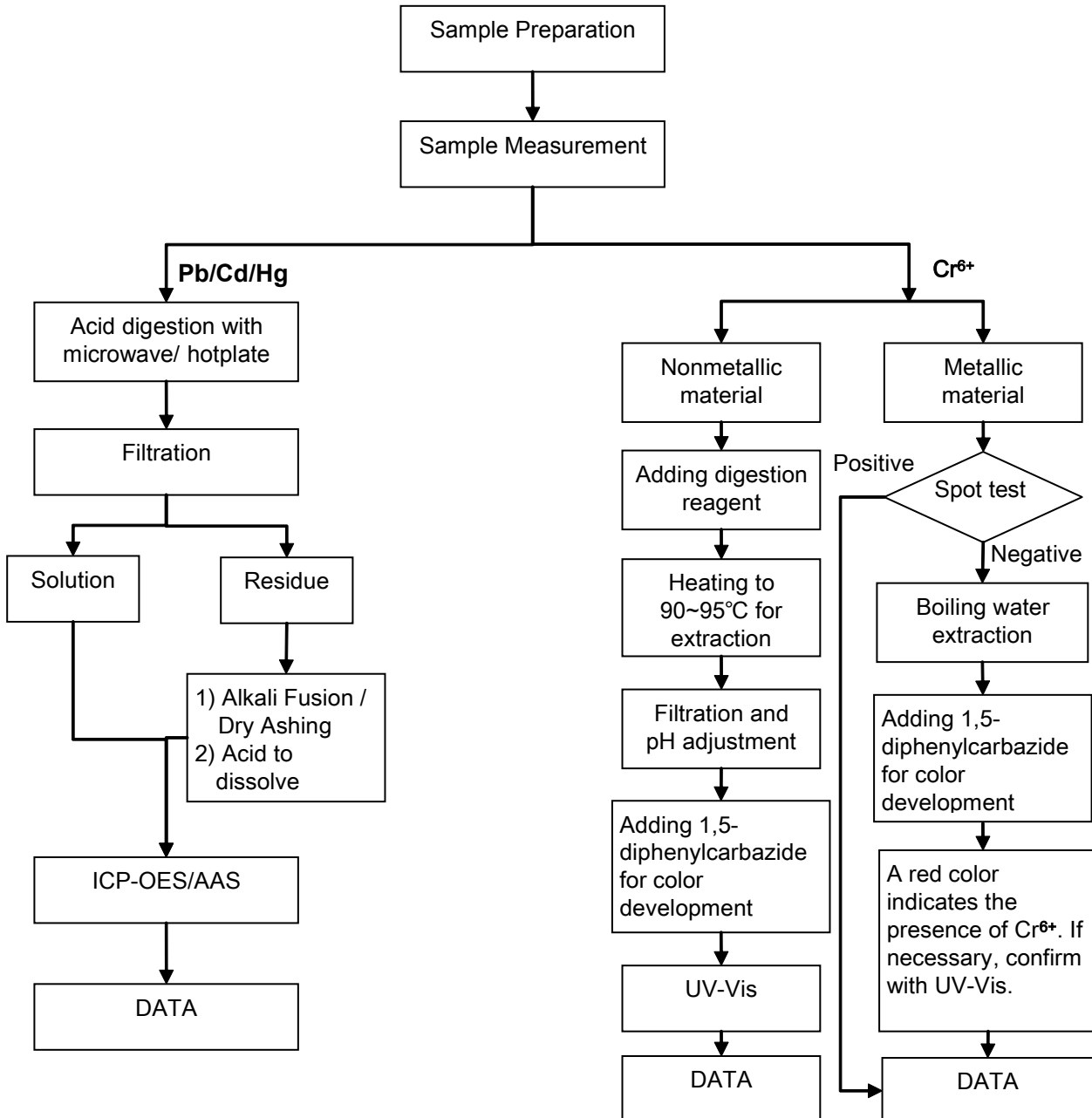

This document is issued by the Company subject to its General Conditions of Service printed overleaf, available on request or accessible at <http://www.sgs.com/en/Terms-and-Conditions.aspx> and, for electronic format documents, subject to Terms and Conditions for Electronic Documents at <http://www.sgs.com/en/Terms-and-Conditions/Terms-e-Documents.aspx>. Attention is drawn to the limitation of liability, indemnification and jurisdiction issues defined therein. Any holder of this document is advised that information contained hereon reflects the Company's findings at the time of its intervention only and within the limits of Client's instructions, if any. The Company's sole responsibility is to its Client and this document does not exonerate parties to a transaction from exercising all their rights and obligations under the transaction documents. This document cannot be reproduced except in full, without prior written approval of the Company. Any unauthorized alteration, forgery or falsification of the content or appearance of this document is unlawful and offenders may be prosecuted to the fullest extent of the law. Unless otherwise stated the results shown in this test report refer only to the sample(s) tested.

Attention: To check the authenticity of testing /inspection report & certificate, please contact us at telephone: (86-755) 8307 1443, or email: CN.Doccheck@sgs.com

No. 31 Xianghong Road, Xiang'An Torch Industrial Zone, Xiamen, Fujian Province, China 361101 t (86-592) 5766995 f (86-592) 5766999 www.sgsgroup.com.cn
 中国·福建·厦门市火炬(翔安)产业区翔虹路31号 邮编: 361101 t (86-592) 5766995 f (86-592) 5766999 e sgs.china@sgs.com

Sample photo:

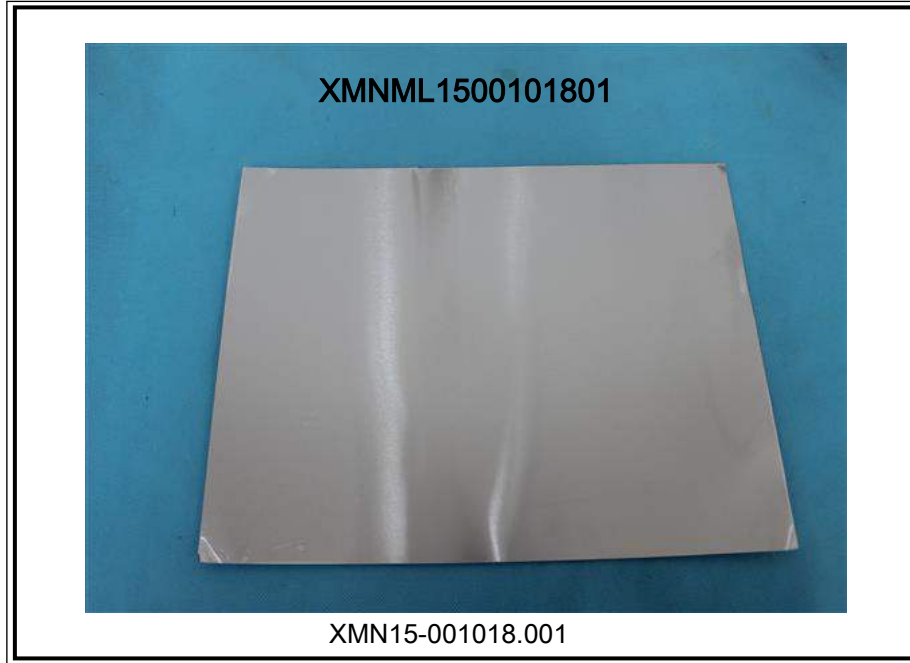

SGS authenticate the photo on original report only

*** End of Report ***



This document is issued by the Company subject to its General Conditions of Service printed overleaf, available on request or accessible at <http://www.sgs.com/en/Terms-and-Conditions.aspx> and, for electronic format documents, subject to Terms and Conditions for Electronic Documents at <http://www.sgs.com/en/Terms-and-Conditions/Terms-e-Document.aspx>. Attention is drawn to the limitation of liability, indemnification and jurisdiction issues defined therein. Any holder of this document is advised that information contained hereon reflects the Company's findings at the time of its intervention only and within the limits of Client's instructions, if any. The Company's sole responsibility is to its Client and this document does not exonerate parties to a transaction from exercising all their rights and obligations under the transaction documents. This document cannot be reproduced except in full, without prior written approval of the Company. Any unauthorized alteration, forgery or falsification of the content or appearance of this document is unlawful and offenders may be prosecuted to the fullest extent of the law. Unless otherwise stated the results shown in this test report refer only to the sample(s) tested.
Attention: To check the authenticity of testing /inspection report & certificate, please contact us at telephone: (86-755) 8307 1443, or email: CN.Doccheck@sgs.com

Test Report

Report No. SCL01H000844001

Page 1 of 7

Applicant JCC COPPER STRIP COMPANY LIMITED

Address 979 GAOXIN AVENUE, NANCHANG STATE HIGH-TECH INDUSTRY
DEVELOPMENT ZONE, NANCHANG CITY, JIANGXI 330096 CHINA

The following sample(s) and sample information was/were submitted and identified by/on the behalf of the client

Sample Name Cu
Material 1100
Sample Received Date Jan. 6, 2015
Testing Period Jan. 6, 2015 to Jan. 10, 2015

Test Requested As specified by client, to screen the 66 substances of very high concern(SVHC) under Regulation(EC) No 1907/2006 of REACH in the submitted sample(s).

Test Method Please refer to the following page(s).

Test Result(s) Please refer to the following page(s).

Summary According to the analytical results, concentrations of 66 SVHC substances are all less than 0.1%(w/w) in the submitted sample(s).

Tested by

Mike

Reviewed by

Cathy

Approved by

Danny Liu

Date

Jan. 10, 2015

Danny Liu

Technical Manager

No. R187216881

Centre Testing International (Shenzhen) Co., Ltd.

Hongwei Industrial Zone, Bao'an 70 District, Shenzhen, Guangdong, China

Test Report

Report No. SCL01H000844001

Page 2 of 7

Test Result(s)

No.	Substance Name(s)	CAS No.	EC No.	Concentration (%)	Report Limit
1	Cobalt dichloride*	7646-79-9	231-589-4	N.D.	0.01%
2	Diarsenic pentoxide*	1303-28-2	215-116-9	N.D.	0.01%
3	Diarsenic trioxide*	1327-53-3	215-481-4	N.D.	0.01%
4	Sodium dichromate*	7789-12-0/ 10588-01-9	234-190-3	N.D.	0.01%
5	Lead hydrogen arsenate*	7784-40-9	232-064-2	N.D.	0.01%
6	Triethyl arsenate*	15606-95-8	427-700-2	N.D.	0.01%
7	[®] Lead chromate	7758-97-6	231-846-0	N.D.	0.05%
8	[®] Lead chromate molybdate sulphate red (C.I. Pigment Red 104)***	12656-85-8	235-759-9	N.D.	0.05%
9	[®] Lead sulphochromate yellow (C.I. Pigment Yellow 34)***	1344-37-2	215-693-7	N.D.	0.05%
10	[®] Boric acid	10043-35-3 11113-50-1	233-139-2 234-343-4	N.D.	0.01%
11	[®] Disodium tetraborate, anhydrous*****	1330-43-4 12179-04-3 1303-96-4	215-540-4	N.D.	0.01%
12	[®] Tetraboron disodium heptaoxide, hydrate*****	12267-73-1	235-541-3	N.D.	0.01%
13	Sodium chromate*	7775-11-3	231-889-5	N.D.	0.01%
14	Potassium chromate*	7789-00-6	232-140-5	N.D.	0.01%
15	Ammonium dichromate*	7789-09-5	232-143-1	N.D.	0.01%
16	Potassium dichromate*	7778-50-9	231-906-6	N.D.	0.01%
17	Cobalt(II) sulphate*	10124-43-3	233-334-2	N.D.	0.01%
18	Cobalt(II) dinitrate*	10141-05-6	233-402-1	N.D.	0.01%
19	Cobalt(II) carbonate*	513-79-1	208-169-4	N.D.	0.01%
20	Cobalt(II) diacetate*	71-48-7	200-755-8	N.D.	0.01%
21	Chromium trioxide*	1333-82-0	215-607-8	N.D.	0.01%
22	[®] Acids generated from chromium trioxide and their oligomers: Chromic acid, Dichromic acid, Oligomers of chromic acid and dichromic acid*	7738-94-5 13530-68-2	231-801-5 236-881-5	N.D.	0.01%
23	Strontium chromate*	7789-06-2	232-142-6	N.D.	0.01%
24	Dichromium tris(chromate)*	24613-89-6	246-356-2	N.D.	0.01%

Test Report

Report No. SCL01H000844001

Page 3 of 7

No.	Substance Name(s)	CAS No.	EC No.	Concentration (%)	Report Limit
25	Potassium hydroxyoctaoxodizincate di chromate*	11103-86-9	234-329-8	N.D.	0.01%
26	Pentazinc chromate octahydroxide*	49663-84-5	256-418-0	N.D.	0.01%
27	Aluminosilicate Refractory Ceramic Fibres (RCF) **	-	-	N.D.	0.05%
28	Zirconia Aluminosilicate Refractory Ceramic Fibres (Zr-RCF) **	-	-	N.D.	0.05%
29	Arsenic acid*	7778-39-4	231-901-9	N.D.	0.01%
30	Calcium arsenate*	7778-44-1	231-904-5	N.D.	0.01%
31	Trilead diarsenate*	3687-31-8	222-979-5	N.D.	0.01%
32	Lead diazide*	13424-46-9	236-542-1	N.D.	0.01%
33	Lead 2,4,6-trinitro-m-phenylene dioxide (Lead styphrate)*	15245-44-0	239-290-0	N.D.	0.01%
34	Lead dipicrate*	6477-64-1	229-335-2	N.D.	0.01%
35	Diboron trioxide	1303-86-2	215-125-8	N.D.	0.01%
36	Lead(II) bis methanesulfonate*	17570-76-2	401-750-5	N.D.	0.01%
37	Pentalead tetraoxide sulphate*	12065-90-6	235-067-7	N.D.	0.01%
38	Dioxobis(stearato)trilead*	12578-12-0	235-702-8	N.D.	0.01%
39	Lead dinitrate*	10099-74-8	233-245-9	N.D.	0.01%
40	Tetrolead trioxide sulphate*	12202-17-4	235-380-9	N.D.	0.01%
41	Lead monoxide (lead oxide)*	1317-36-8	215-267-0	N.D.	0.01%
42	Lead titanium trioxide*	12060-00-3	235-038-9	N.D.	0.01%
43	Acetic acid, lead salt, basic*	51404-69-4	257-175-3	N.D.	0.01%
44	Pyrochlore, antimony lead yellow*	8012-00-8	232-382-1	N.D.	0.01%
45	Tetraethyllead*	78-00-2	201-075-4	N.D.	0.01%
46	[Phthalato(2-)]dioxotrilead*	69011-06-9	273-688-5	N.D.	0.01%
47	Lead cyanamidate*	20837-86-9	244-073-9	N.D.	0.01%
48	Silicic acid (H ₂ Si ₂ O ₅), barium salt (1:1), lead-doped*	68784-75-8	272-271-5	N.D.	0.01%
49	Trilead dioxide phosphonate*	12141-20-7	235-252-2	N.D.	0.01%
50	Lead titanium zirconium oxide*	12626-81-2	235-727-4	N.D.	0.01%
51	Trilead bis(carbonate)dihydroxide*	1319-46-6	215-290-6	N.D.	0.01%
52	Fatty acids, C16-18, lead salts*	91031-62-8	292-966-7	N.D.	0.01%
53	Orange lead (lead tetroxide)*	1314-41-6	215-235-6	N.D.	0.01%
54	Sulfurous acid, lead salt, dibasic*	62229-08-7	263-467-1	N.D.	0.01%
55	Lead oxide sulfate*	12036-76-9	234-853-7	N.D.	0.01%
56	Lead bis(tetra fluoroborate)*	13814-96-5	237-486-0	N.D.	0.01%

Test Report

Report No. SCL01H000844001

Page 4 of 7

No.	Substance Name(s)	CAS No.	EC No.	Concentration (%)	Report Limit
57	Silicic acid, lead salt*	11120-22-2	234-363-3	N.D.	0.01%
58	Cadmium	7440-43-9	231-152-8	N.D.	0.01%
59	Cadmium oxide*	1306-19-0	215-146-2	N.D.	0.01%
60	Cadmium sulphide*	1306-23-6	215-147-8	N.D.	0.01%
61	Lead di(acetate)*	301-04-2	206-104-4	N.D.	0.01%
62	Cadmium chloride*	10108-64-2	233-296-7	N.D.	0.01%
63	[®] Sodium perborate, perboric acid, sodium salt*****	-	239-172-9, 234-390-0	N.D.	0.01%
64	[®] Sodium peroxometaborate*****	7632-04-4	231-556-4	N.D.	0.01%
65	Cadmium fluoride*	7790-79-6	232-222-0	N.D.	0.01%
66	Cadmium sulphate*	10124-36-4; 31119-53-6	233-331-6	N.D.	0.01%

Test Method:

Refer to US EPA3052:1996, US EPA 3050B:1996, US EPA 3060A:1996, B S EN 14582:2007 for sample pretreatment.

Analyzed by ICP-OES, UV-Vis and IC.

Tested Sample/Part Description Cupreous metal

Test Report

Report No. SCL01H000844001

Page 5 of 7

Note:

1. w/w = weight by weight; 0.1% = 1000 mg/kg = 1000 ppm
2. N.D. = Not Detected (<report limit)
3. *: Concentration value of the substance by the conversion from the test results of certain elements.
4. **: All refractory ceramic fibres are covered by index number 650-017-00-8 in Annex VI of the Regulation on Classification, Labeling and Packaging of chemical substances and mixtures, the so called CLP Regulation (Regulation (EC) No 1272/2008).
5. ***: C.I.: Colour Index
6. *****: Concentration value of Disodium tetraborate, anhydrous and Tetraboron disodium heptaoxide, hydrate is evaluated by Disodium tetraborate, with no consider of the hydrate. Concentration value of Sodium perborate, perboric acid, sodium salt; Sodium peroxometaborate is evaluated by Sodium perborate, with no consider of the hydrate.
7. [Ⓞ]: In view of the substances are established as UVCB substances (substances of unknown or variable composition, complex reaction products or biological materials) consisting of different and variable constituents, the test results are calculated based on the main constituents of the representative compounds for substances.
8. [Ⓞ]: In view of the substance contain variable substances, the test results are calculated based on main constituents of the representative compounds for the substances, and the test results of the representative compounds are calculated based on the result of specified heavy metal elements.
9. [Ⓞ]: Concentration value of Boric acid; Disodium tetraborate, anhydrous; Tetraboron disodium heptaoxide, hydrate; Diboron trioxide; Sodium perborate; perboric acid, sodium salt; Sodium peroxometaborate is calculated by the conversion from the test results of certain elements and confirmed by appropriate solvent extraction, meanwhile the book of materials is suggested to be checked for further confirmation.

Test Report

Report No. SCL01H000844001

Page 6 of 7

Appendix:

1. Any supplier of an article containing a substance that is included in the Candidate List in a concentration above 0.1 % weight by weight (w/w) has the duty to communicate information in accordance with Article 33 of European Union regulation concerning the Registration, Evaluation, Authorization and Restriction of Chemicals (REACH).
 - 1) Any supplier shall provide the recipient of the article with sufficient information to allow safe use of the article including, as a minimum, the name of that substance.
 - 2) On request by a consumer any supplier shall provide the consumer with sufficient information to allow safe use of the article including, as a minimum, the name of that substance within 45 days of receipt of the request, free of charge.
2. The supplier of a substance that is included in the Candidate List on their own shall provide the recipient of the substance with a safety data sheet for free compiled in accordance with Article 3 and Annex II of REACH.
3. The supplier of a mixture that containing a substance that is included in the Candidate List shall exchange information in accordance with Article 31, Article 32, and Annex II of REACH.
 - 1) Any supplier shall provide the recipient of the mixture with a safety data sheet for free where a preparation meets the criteria for classification as dangerous in accordance with Directives 1999/45/EC.
 - 2) Any supplier shall provide the recipient of the mixture with a safety data sheet for free where a preparation does not meet the criteria for classification as dangerous in accordance with Directive 1999/45/EC, but contains any substance that is included in the Candidate List in an individual concentration of ≥ 0.1 % by weight for non-gaseous mixtures or ≥ 0.2 % by volume for gaseous mixtures.

Test Report

Report No. SCL01H000844001

Page 7 of 7

Test Process

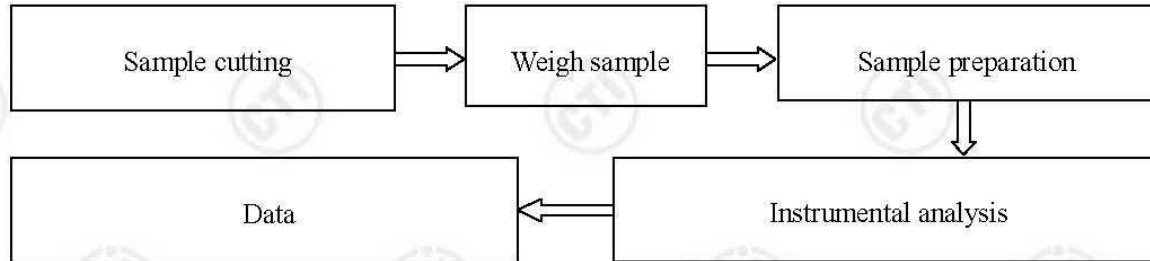

Photo(s) of the sample(s)



*** End of Report ***

The test report is effective only with both signature and specialized stamp. The result(s) shown in this report refer only to the sample(s) tested. Without written approval of CTI, this report can't be reproduced except in full.

Test Report

No. CANML1415897905

Date: 09 Oct 2014

Page 1 of 12

LUVATA TUBE (ZHONGSHAN) LTD

NO.96,XING PU ROAD WEST,HUANG PU TOWN,ZHONG SHAN CITY,GUANG DONG PROVINCE
CHINA

The following sample(s) was/were submitted and identified on behalf of the clients as :
E-cooling COPPER TUBE

SGS Job No. : GZIN1409029086PC - GZ
Tested Sample Info. : C1020
Client Ref. Info. : C1020/C10200/TU1/TU2/T2
Date of Sample Received : 25 Sep 2014
Testing Period : 25 Sep 2014 - 30 Sep 2014
Test Requested : Selected test(s) as requested by client.
Test Method : Please refer to next page(s).
Test Results : Please refer to next page(s).
Conclusion : Based on the performed tests on submitted sample(s), the results of Lead, Mercury, Cadmium, Hexavalent chromium, Polybrominated biphenyls (PBBs), Polybrominated diphenyl ethers (PBDEs) comply with the limits as set by RoHS Directive 2011/65/EU Annex II; recasting 2002/95/EC.

Signed for and on behalf of
SGS-CSTC Ltd.



Alkene_Liang
Approved Signatory



This document is issued by the Company subject to its General Conditions of Service printed overleaf, available on request or accessible at <http://www.sgs.com/en/Terms-and-Conditions.aspx> and, for electronic format documents, subject to Terms and Conditions for Electronic Documents at <http://www.sgs.com/en/Terms-and-Conditions/Terms-e-Document.aspx>. Attention is drawn to the limitation of liability, indemnification and jurisdiction issues defined therein. Any holder of this document is advised that information contained hereon reflects the Company's findings at the time of its intervention only and within the limits of Client's instructions, if any. The Company's sole responsibility is to its Client and this document does not exonerate parties to a transaction from exercising all their rights and obligations under the transaction documents. This document cannot be reproduced except in full, without prior written approval of the Company. Any unauthorized alteration, forgery or falsification of the content or appearance of this document is unlawful and offenders may be prosecuted to the fullest extent of the law. Unless otherwise stated the results shown in this test report refer only to the sample(s) tested.
Attention: To check the authenticity of testing/inspection report & certificate, please contact us at telephone: (86-755) 8307 1443, or email: CN.Qcscheck@sgs.com

Test Results :

Test Part Description :

Specimen No.	SGS Sample ID	Description
SN1	CAN14-158979.002	Copper-colored metal tube

Remarks :

- (1) 1 mg/kg = 1 ppm = 0.0001%
- (2) MDL = Method Detection Limit
- (3) ND = Not Detected (< MDL)
- (4) "-" = Not Regulated

RoHS Directive 2011/65/EU

- Test Method :
- (1) With reference to IEC 62321-5:2013, determination of Cadmium by ICP-OES.
 - (2) With reference to IEC 62321-5:2013, determination of Lead by ICP-OES.
 - (3) With reference to IEC 62321-4:2013, determination of Mercury by ICP-OES.
 - (4) With reference to IEC 62321:2008, determination of Hexavalent Chromium by spot test / Colorimetric Method using UV-Vis.
 - (5) With reference to IEC 62321:2008, determination of PBBs and PBDEs by GC-MS.

Test Item(s)	Limit	Unit	MDL	002
Cadmium (Cd)	100	mg/kg	2	ND
Lead (Pb)	1,000	mg/kg	2	ND
Mercury (Hg)	1,000	mg/kg	2	ND
Hexavalent Chromium (CrVI)	-	-	◇	Negative
Sum of PBBs	1,000	mg/kg	-	ND
Monobromobiphenyl	-	mg/kg	5	ND
Dibromobiphenyl	-	mg/kg	5	ND
Tribromobiphenyl	-	mg/kg	5	ND
Tetrabromobiphenyl	-	mg/kg	5	ND
Pentabromobiphenyl	-	mg/kg	5	ND
Hexabromobiphenyl	-	mg/kg	5	ND
Heptabromobiphenyl	-	mg/kg	5	ND
Octabromobiphenyl	-	mg/kg	5	ND
Nonabromobiphenyl	-	mg/kg	5	ND
Decabromobiphenyl	-	mg/kg	5	ND
Sum of PBDEs	1,000	mg/kg	-	ND
Monobromodiphenyl ether	-	mg/kg	5	ND



This document is issued by the Company subject to its General Conditions of Service printed overleaf, available on request or accessible at <http://www.sgs.com/en/Terms-and-Conditions.aspx> and, for electronic format documents, subject to Terms and Conditions for Electronic Documents at <http://www.sgs.com/en/Terms-and-Conditions/Terms-e-Document.aspx>. Attention is drawn to the limitation of liability, indemnification and jurisdiction issues defined therein. Any holder of this document is advised that information contained hereon reflects the Company's findings at the time of its intervention only and within the limits of Client's instructions, if any. The Company's sole responsibility is to its Client and this document does not exonerate parties to a transaction from exercising all their rights and obligations under the transaction documents. This document cannot be reproduced except in full, without prior written approval of the Company. Any unauthorized alteration, forgery or falsification of the content or appearance of this document is unlawful and offenders may be prosecuted to the fullest extent of the law. Unless otherwise stated the results shown in this test report refer only to the sample(s) tested.

Attention: To check the authenticity of testing / inspection report & certificate, please contact us at telephone: (86-755) 8307 1443, or email: CN.Doccheck@sgs.com

Test Report

No. CANML1415897905

Date: 09 Oct 2014

Page 3 of 12

<u>Test Item(s)</u>	<u>Limit</u>	<u>Unit</u>	<u>MDL</u>	<u>002</u>
Dibromodiphenyl ether	-	mg/kg	5	ND
Tribromodiphenyl ether	-	mg/kg	5	ND
Tetrabromodiphenyl ether	-	mg/kg	5	ND
Pentabromodiphenyl ether	-	mg/kg	5	ND
Hexabromodiphenyl ether	-	mg/kg	5	ND
Heptabromodiphenyl ether	-	mg/kg	5	ND
Octabromodiphenyl ether	-	mg/kg	5	ND
Nonabromodiphenyl ether	-	mg/kg	5	ND
Decabromodiphenyl ether	-	mg/kg	5	ND

Notes :

(1) The maximum permissible limit is quoted from the directive 2011/65/EU, Annex II

(2) ◊Spot-test:

Negative = Absence of CrVI coating, Positive = Presence of CrVI coating;

(The tested sample should be further verified by boiling-water-extraction method if the spot test result is Negative or cannot be confirmed.)

◊Boiling-water-extraction:

Negative = Absence of CrVI coating

Positive = Presence of CrVI coating; the detected concentration in boiling-water-extraction solution is equal or greater than 0.02 mg/kg with 50 cm² sample surface area.

Information on storage conditions and production date of the tested sample is unavailable and thus results of Cr(VI) represent status of the sample at the time of testing.

Halogen

Test Method : With reference to EN 14582: 2007, analysis was performed by Ion Chromatograph (IC).

<u>Test Item(s)</u>	<u>Unit</u>	<u>MDL</u>	<u>002</u>
Fluorine (F)	mg/kg	50	ND
Chlorine (Cl)	mg/kg	50	ND
Bromine (Br)	mg/kg	50	ND
Iodine (I)	mg/kg	50	ND

Elementary Analysis

Test Method : With reference to US EPA Method 3050B:1996, analysis was performed by ICP-OES.



This document is issued by the Company subject to its General Conditions of Service printed overleaf, available on request or accessible at <http://www.sgs.com/en/Terms-and-Conditions.aspx> and, for electronic format documents, subject to Terms and Conditions for Electronic Documents at <http://www.sgs.com/en/Terms-and-Conditions/Terms-e-Document.aspx>. Attention is drawn to the limitation of liability, indemnification and jurisdiction issues defined therein. Any holder of this document is advised that information contained hereon reflects the Company's findings at the time of its intervention only and within the limits of Client's instructions, if any. The Company's sole responsibility is to its Client and this document does not exonerate parties to a transaction from exercising all their rights and obligations under the transaction documents. This document cannot be reproduced except in full, without prior written approval of the Company. Any unauthorized alteration, forgery or falsification of the content or appearance of this document is unlawful and offenders may be prosecuted to the fullest extent of the law. Unless otherwise stated the results shown in this test report refer only to the sample(s) tested.

Attention: To check the authenticity of testing/inspection report & certificate, please contact us at telephone: (86-755)8307 1443, or email: CN.Doccheck@sgs.com

Test Report

No. CANML1415897905

Date: 09 Oct 2014

Page 4 of 12

<u>Test Item(s)</u>	<u>Unit</u>	<u>MDL</u>	<u>002</u>
Nickel (Ni)	mg/kg	5	ND

Hexabromocyclododecane (HBCDD)

Test Method : Determination of HBCDD by GC-MS based on IEC 62321:2008.

<u>Test Item(s)</u>	<u>Unit</u>	<u>MDL</u>	<u>002</u>
Hexabromocyclododecane (HBCDD)	mg/kg	10	ND

Notes :

- (1) Reference Information: Directive 2011/65/EU recasting RoHS directive 2002/95/EC:
Hexabromocyclododecane (HBCDD) is considered as a priority for risk evaluation and substance restriction.

PFOS (Perfluorooctane Sulfonates) and PFOA (Perfluorooctanoic Acid)

Test Method : With reference to US EPA Method 3550C: 2007, analysis was performed by HPLC-MS.

<u>Test Item(s)</u>	<u>Unit</u>	<u>MDL</u>	<u>002</u>
Perfluorooctane Sulfonates (PFOS) and related Acid, Metal Salt and Amide	mg/kg	10	ND
Perfluorooctanoic Acid (PFOA)	mg/kg	10	ND

Notes :

- For reference: commission regulation (EU) No 757/2010 amending regulation (EC) No 850/2004:
(1) For the purposes of this entry, Article 4(1) (b) shall apply to concentrations of PFOS equal to or below 10 mg/kg (0,001 % by weight) when it occurs in substances or in preparations.
(2) For the purposes of this entry, Article 4(1) (b) shall apply to concentrations of PFOS in semi-finished products or articles, or parts thereof, if the concentration of PFOS is lower than 0,1 % by weight calculated with reference to the mass of structurally or micro-structurally distinct parts that contain PFOS or, for textiles or other coated materials, if the amount of PFOS is lower than 1µg /m² of the coated material.

Phthalate

Test Method : Determination of phthalates by GC-MS based on EN 14372:2004.



This document is issued by the Company subject to its General Conditions of Service printed overleaf, available on request or accessible at <http://www.sgs.com/en/Terms-and-Conditions.aspx> and, for electronic format documents, subject to Terms and Conditions for Electronic Documents at <http://www.sgs.com/en/Terms-and-Conditions/Terms-e-Documents.aspx>. Attention is drawn to the limitation of liability, indemnification and jurisdiction issues defined therein. Any holder of this document is advised that information contained hereon reflects the Company's findings at the time of its intervention only and within the limits of Client's instructions, if any. The Company's sole responsibility is to its Client and this document does not exonerate parties to a transaction from exercising all their rights and obligations under the transaction documents. This document cannot be reproduced except in full, without prior written approval of the Company. Any unauthorized alteration, forgery or falsification of the content or appearance of this document is unlawful and offenders may be prosecuted to the fullest extent of the law. Unless otherwise stated the results shown in this test report refer only to the sample(s) tested.

Attention: To check the authenticity of testing/inspection report & certificate, please contact us at telephone: (86-755) 8307 1443, or email: CN.Doccheck@sgs.com

SGS Scientific Technical Services Co., Ltd.
Guangzhou Scientific Technical Services Laboratory

136 Kexu Road, Science Park Guangzhou Economic & Technology Development District, Guangzhou, China 510663 1 (86-20) 82155555 1 (86-20) 82075113 www.sgs.com
中国·广州·经济技术开发区科学城科珠路198号 邮编: 510663 1 (86-20) 82155555 1 (86-20) 82075113 * sgs.china@sgs.com

Test Report

No. CANML1415897905

Date: 09 Oct 2014

Page 5 of 12

<u>Test Item(s)</u>	<u>CAS NO.</u>	<u>Unit</u>	<u>MDL</u>	<u>002</u>
Dibutyl Phthalate (DBP)	84-74-2	%(w/w)	0.003	ND
Benzylbutyl Phthalate (BBP)	85-68-7	%(w/w)	0.003	ND
Bis-(2-ethylhexyl) Phthalate (DEHP)	117-81-7	%(w/w)	0.003	ND
Diisobutyl Phthalate (DIBP)	84-69-5	%(w/w)	0.003	ND

Notes :

- (1) Reference Information: Directive 2011/65/EU recasting RoHS directive 2002/95/EC:
Bis (2-ethylhexyl) phthalate (DEHP), Butyl benzyl phthalate (BBP) and Dibutyl phthalate (DBP) are considered as a priority for risk evaluation and substance restriction.



This document is issued by the Company subject to its General Conditions of Service printed overleaf, available on request or accessible at <http://www.sgs.com/en/Terms-and-Conditions.aspx> and, for electronic format documents, subject to Terms and Conditions for Electronic Documents at <http://www.sgs.com/en/Terms-and-Conditions/Terms-e-Document.aspx>. Attention is drawn to the limitation of liability, indemnification and jurisdiction issues defined therein. Any holder of this document is advised that information contained hereon reflects the Company's findings at the time of its intervention only and within the limits of Client's instructions, if any. The Company's sole responsibility is to its Client and this document does not exonerate parties to a transaction from exercising all their rights and obligations under the transaction documents. This document cannot be reproduced except in full, without prior written approval of the Company. Any unauthorized alteration, forgery or falsification of the content or appearance of this document is unlawful and offenders may be prosecuted to the fullest extent of the law. Unless otherwise stated the results shown in this test report refer only to the sample(s) tested.
Attention: To check the authenticity of testing/inspection report & certificate, please contact us at telephone: (86-755) 8307 1443, or email: CN.Doccheck@sgs.com

SGS Sertens Technical Services Co., Ltd
Guangzhou, China
Guangzhou, China
Guangzhou, China

196 Kechu Road, Science Park Guangzhou Economic & Technology Development District, Guangzhou, China 510663 t (86-20) 82155555 f (86-20) 82075113 www.sgs.com.cn
中国·广州·经济技术开发区科学城科珠路196号 邮编: 510663 t (86-20) 82155555 f (86-20) 82075113 e sgs.china@sgs.com

ATTACHMENTS

RoHS Testing Flow Chart

- 1) Name of the person who made testing: Bruce Xiao / Sunny Hu
- 2) Name of the person in charge of testing: Bella Wang / Cutey Yu
- 3) These samples were dissolved totally by pre-conditioning method according to below flow chart (Cr⁶⁺ and PBBs/PBDEs test method excluded).

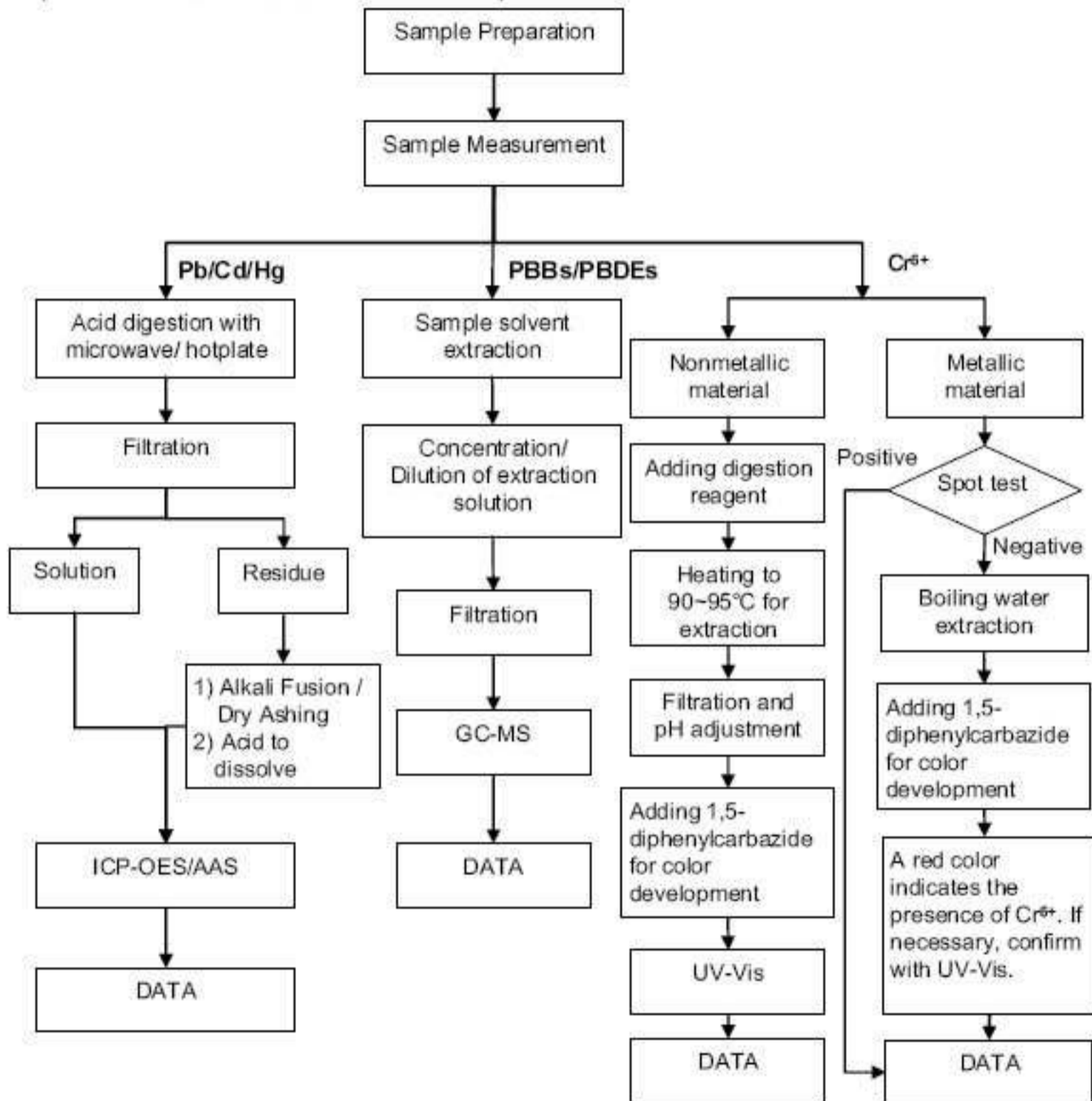

This document is issued by the Company subject to its General Conditions of Service printed overleaf, available on request or accessible at <http://www.sgs.com/en/Terms-and-Conditions.aspx> and, for electronic format documents, subject to Terms and Conditions for Electronic Documents at <http://www.sgs.com/en/Terms-and-Conditions/Terms-e-Document.aspx>. Attention is drawn to the limitation of liability, indemnification and jurisdiction issues defined therein. Any holder of this document is advised that information contained herein reflects the Company's findings at the time of its intervention only and within the limits of Client's instructions, if any. The Company's sole responsibility is to its Client and this document does not exonerate parties to a transaction from exercising all their rights and obligations under the transaction documents. This document cannot be reproduced except in full, without prior written approval of the Company. Any unauthorized alteration, forgery or falsification of the content or appearance of this document is unlawful and offenders may be prosecuted to the fullest extent of the law. Unless otherwise stated the results shown in this test report refer only to the sample(s) tested.

Attention: To check the authenticity of testing/inspection report & certificate, please contact us at telephone: (86-755) 8307 1443, or email: CN.Doccheck@sgs.com

ATTACHMENTS

Elementary Testing Flow Chart

- 1) Name of the person who made testing: Bruce Xiao
- 2) Name of the person in charge of testing: Bella Wang

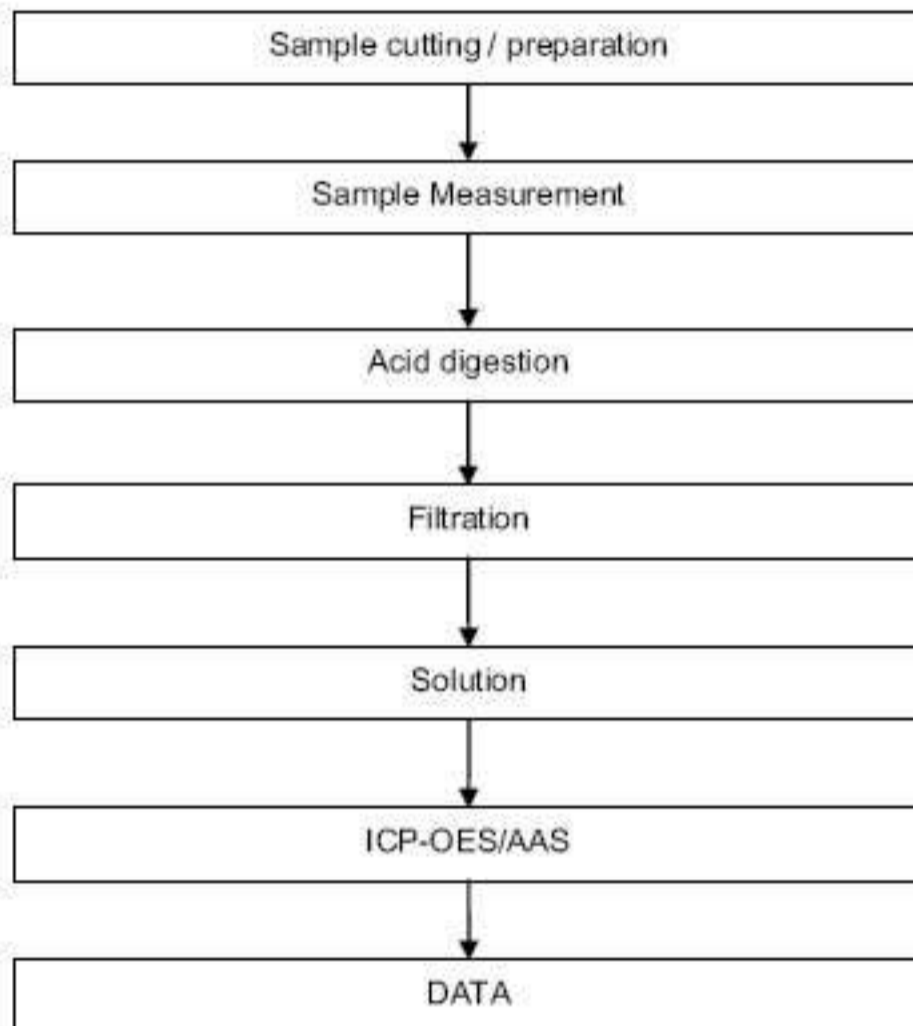

This document is issued by the Company subject to its General Conditions of Service printed overleaf, available on request or accessible at <http://www.sgs.com/en/Terms-and-Conditions.aspx> and, for electronic format documents, subject to Terms and Conditions for Electronic Documents at <http://www.sgs.com/en/Terms-and-Conditions/Terms-e-Document.aspx>. Attention is drawn to the limitation of liability, indemnification and jurisdiction issues defined therein. Any holder of this document is advised that information contained hereon reflects the Company's findings at the time of its intervention only and within the limits of Client's instructions, if any. The Company's sole responsibility is to its Client and this document does not exonerate parties to a transaction from exercising all their rights and obligations under the transaction documents. This document cannot be reproduced except in full, without prior written approval of the Company. Any unauthorized alteration, forgery or falsification of the content or appearance of this document is unlawful and offenders may be prosecuted to the fullest extent of the law. Unless otherwise stated the results shown in this test report refer only to the sample(s) tested.

Attention: To check the authenticity of testing / inspection report & certificate, please contact us at telephone: (86-755) 8307 1443, or email: CN.Doccheck@sgs.com

ATTACHMENTS

Halogen Testing Flow Chart

- 1) Name of the person who made testing: Harming Xiao
- 2) Name of the person in charge of testing: Bella Wang

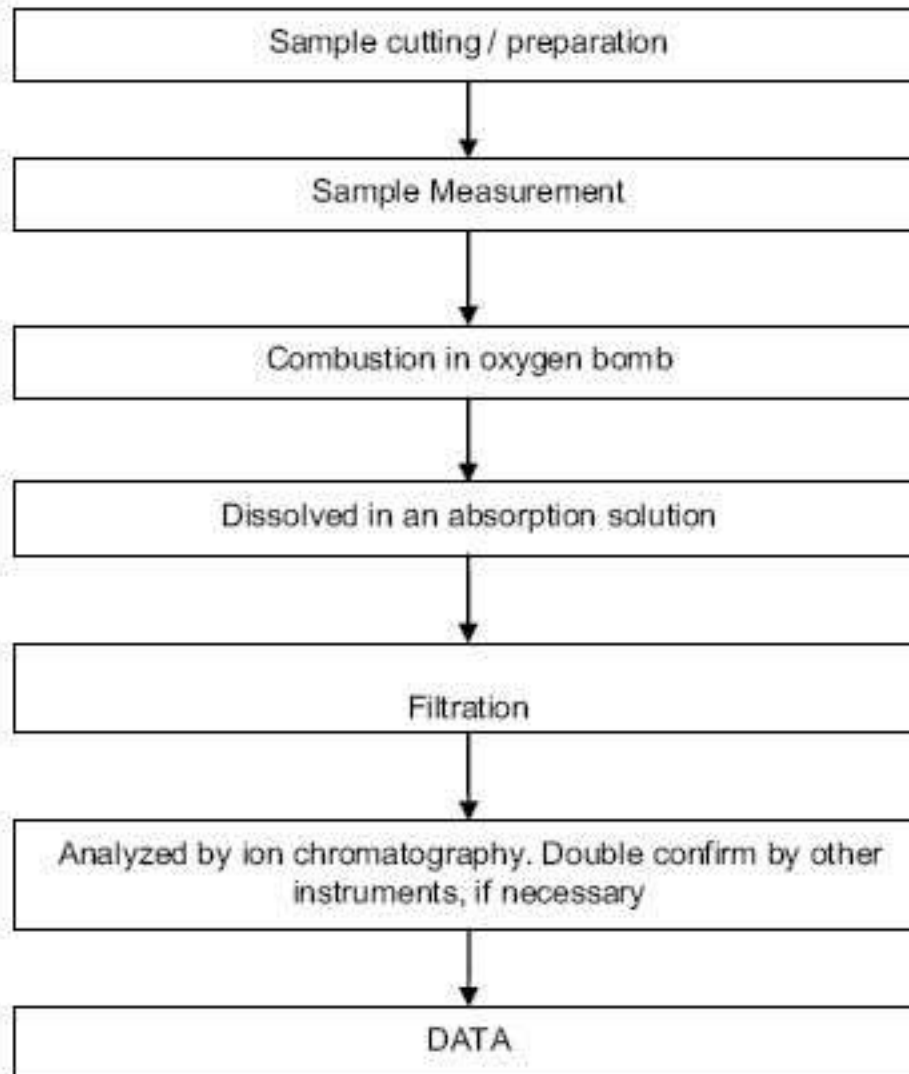

This document is issued by the Company subject to its General Conditions of Service printed overleaf, available on request or accessible at <http://www.sgs.com/en/Terms-and-Conditions.aspx> and, for electronic format documents, subject to Terms and Conditions for Electronic Documents at <http://www.sgs.com/en/Terms-and-Conditions/Terms-e-Document.aspx>. Attention is drawn to the limitation of liability, indemnification and jurisdiction issues defined therein. Any holder of this document is advised that information contained hereon reflects the Company's findings at the time of its intervention only and within the limits of Client's instructions, if any. The Company's sole responsibility is to its Client and this document does not exonerate parties to a transaction from exercising all their rights and obligations under the transaction documents. This document cannot be reproduced except in full, without prior written approval of the Company. Any unauthorized alteration, forgery or falsification of the content or appearance of this document is unlawful and offenders may be prosecuted to the fullest extent of the law. Unless otherwise stated the results shown in this test report refer only to the sample(s) tested.

Attention: To check the authenticity of testing / inspection report & certificate, please contact us at telephone: (86-755) 8307 1443, or email: CN.Doccheck@sgs.com

ATTACHMENTS

Phthalates Testing Flow Chart

- 1) Name of the person who made testing: Sunry Hu
- 2) Name of the person in charge of testing: Cutey Yu

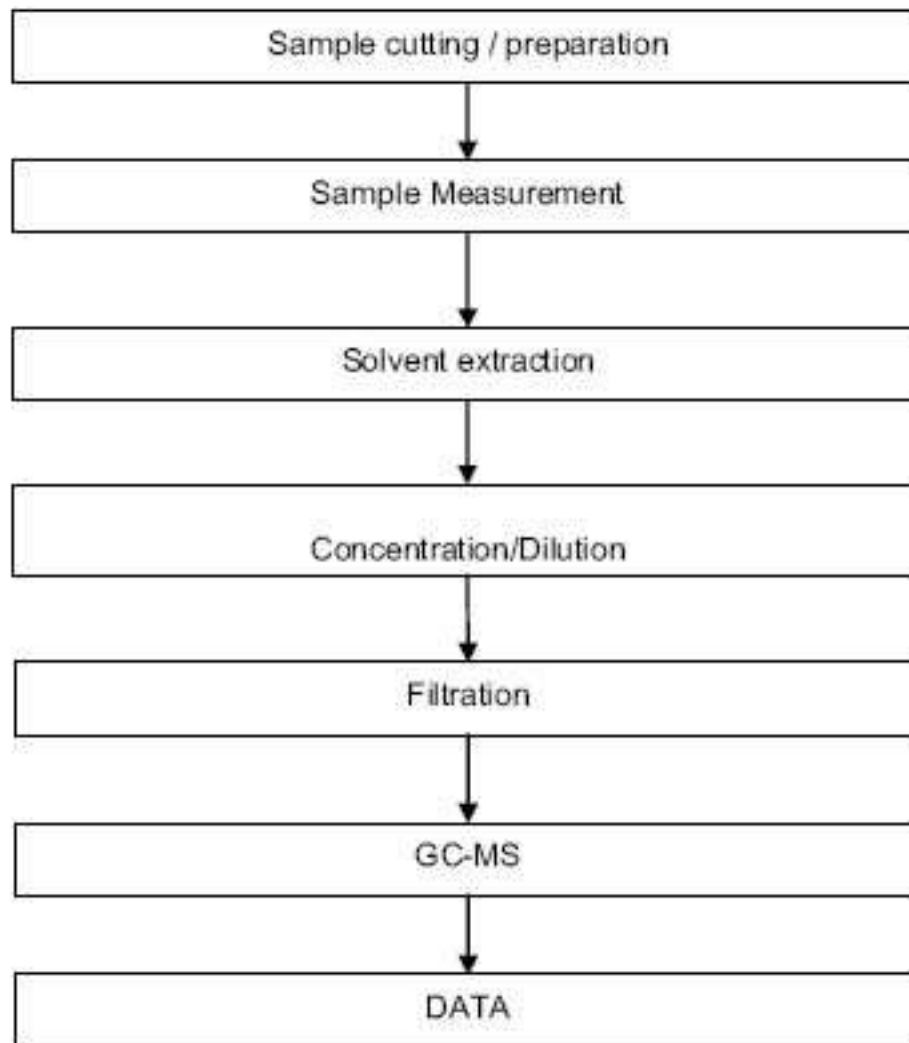

This document is issued by the Company subject to its General Conditions of Service printed overleaf, available on request or accessible at <http://www.sgs.com/en/Terms-and-Conditions.aspx> and, for electronic format documents, subject to Terms and Conditions for Electronic Documents at <http://www.sgs.com/en/Terms-and-Conditions/Terms-e-Document.aspx>. Attention is drawn to the limitation of liability, indemnification and jurisdiction issues defined therein. Any holder of this document is advised that information contained hereon reflects the Company's findings at the time of its intervention only and within the limits of Client's instructions, if any. The Company's sole responsibility is to its Client and this document does not exonerate parties to a transaction from exercising all their rights and obligations under the transaction documents. This document cannot be reproduced except in full, without prior written approval of the Company. Any unauthorized alteration, forgery or falsification of the content or appearance of this document is unlawful and offenders may be prosecuted to the fullest extent of the law. Unless otherwise stated the results shown in this test report refer only to the sample(s) tested.

Attention: To check the authenticity of testing/inspection report & certificates, please contact us at telephone: (86-755) 8307 1443, or email: CN.Docscheck@sgs.com

ATTACHMENTS

PFOA / PFOS Testing Flow Chart

- 1) Name of the person who made testing: Zhihong Wang
- 2) Name of the person in charge of testing: Cutey Yu

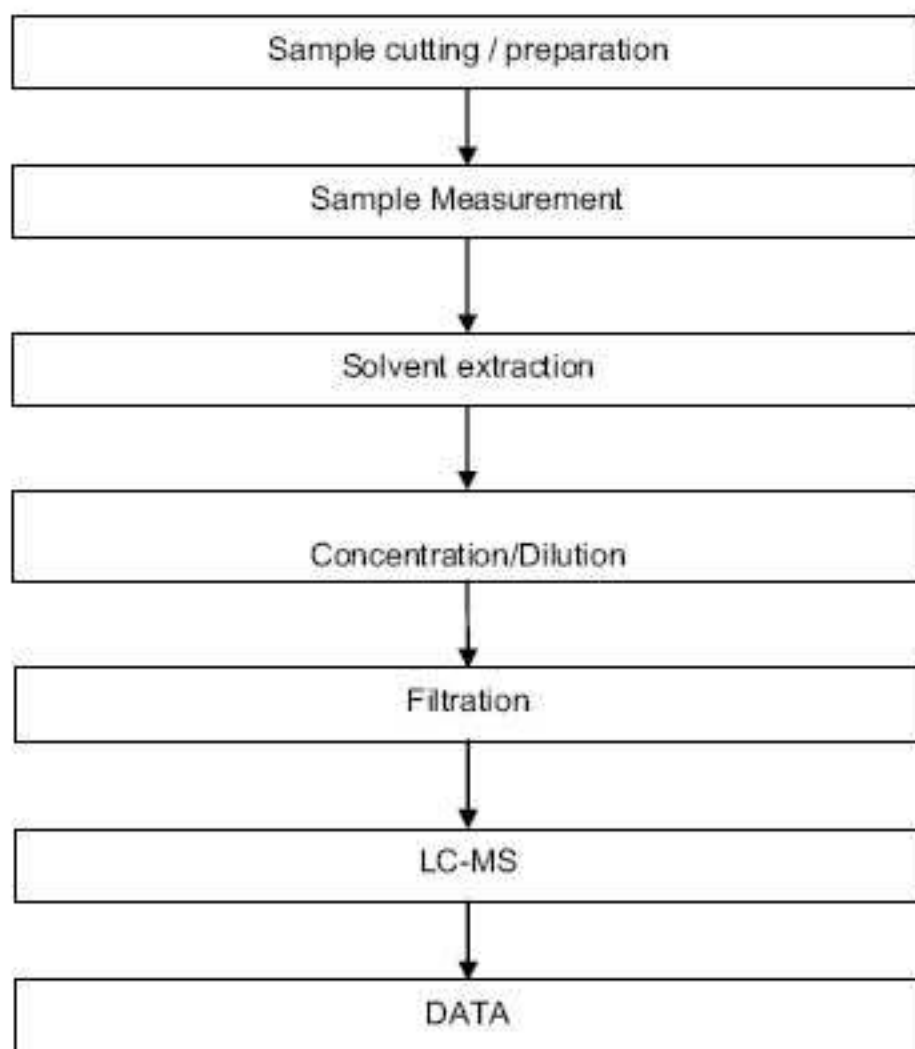

This document is issued by the Company subject to its General Conditions of Service printed overleaf, available on request or accessible at <http://www.sgs.com/en/Terms-and-Conditions.aspx> and, for electronic format documents, subject to Terms and Conditions for Electronic Documents at <http://www.sgs.com/en/Terms-and-Conditions/Terms-e-Document.aspx>. Attention is drawn to the limitation of liability, indemnification and jurisdiction issues defined therein. Any holder of this document is advised that information contained hereon reflects the Company's findings at the time of its intervention only and within the limits of Client's instructions, if any. The Company's sole responsibility is to its Client and this document does not exonerate parties to a transaction from exercising all their rights and obligations under the transaction documents. This document cannot be reproduced except in full, without prior written approval of the Company. Any unauthorized alteration, forgery or falsification of the content or appearance of this document is unlawful and offenders may be prosecuted to the fullest extent of the law. Unless otherwise stated the results shown in this test report refer only to the sample(s) tested.

Attention: To check the authenticity of testing / inspection report & certificate, please contact us at telephone: (86-755) 8307 1443, or email: CN.Doccheck@sgs.com

ATTACHMENTS

HBCDD Testing Flow Chart

- 1) Name of the person who made testing: Sunny Hu
- 2) Name of the person in charge of testing: Cutey Yu

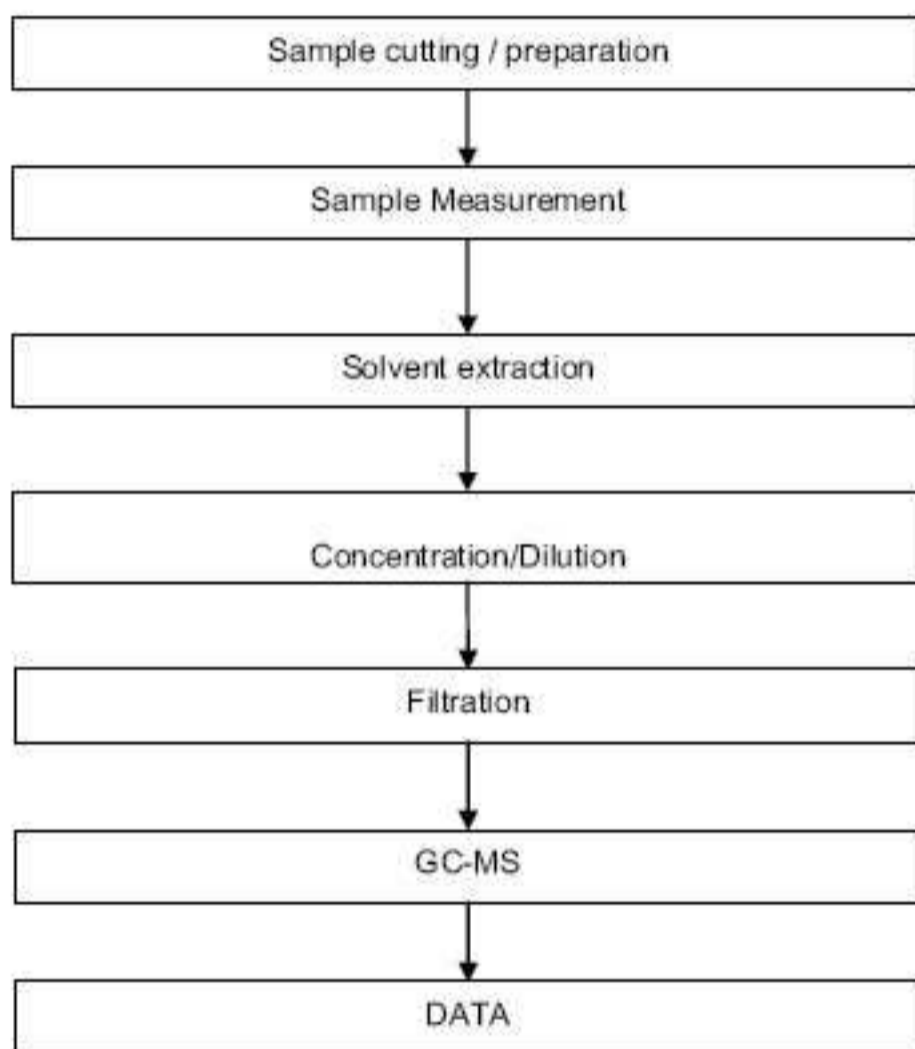

Sample photo:



SGS authenticate the photo on original report only

*** End of Report ***

Test Report

No. CANEC1419449801

Date: 28 Nov 2014

Page 1 of 8

KINGFA SCI. & TECH. CO., LTD.

NO.33 KEFENG ROAD,SCIENCE CITY,GUANGZHOU HI-TECHINDUSTRIAL DEVELOPMENT ZONE,GUANGZHOU CITY CHINA

The following sample(s) was/were submitted and identified on behalf of the clients as : PBT-RG301

SGS Job No. : CP14-062333 - GZ

Date of Sample Received : 24 Nov 2014

Testing Period : 24 Nov 2014 - 28 Nov 2014

Test Requested : Selected test(s) as requested by client.

Test Method : Please refer to next page(s).

Test Results : Please refer to next page(s).

Conclusion : Based on the performed tests on submitted sample(s), the results of Lead, Mercury, Cadmium, Hexavalent chromium, Polybrominated biphenyls (PBBs), Polybrominated diphenyl ethers (PBDEs) comply with the limits as set by RoHS Directive 2011/65/EU Annex II; recasting 2002/95/EC.

Signed for and on behalf of
SGS-CSTC Ltd.



Alkene_Liang
Approved Signatory



This document is issued by the Company subject to its General Conditions of Service printed overleaf, available on request or accessible at <http://www.sgs.com/en/Terms-and-Conditions.aspx> and, for electronic format documents, subject to Terms and Conditions for Electronic Documents at <http://www.sgs.com/en/Terms-and-Conditions/Terms-e-Documents.aspx>. Attention is drawn to the limitation of liability, indemnification and jurisdiction issues defined therein. Any holder of this document is advised that information contained hereon reflects the Company's findings at the time of its intervention only and within the limits of Client's instructions, if any. The Company's sole responsibility is to its Client and this document does not exonerate parties to a transaction from exercising all their rights and obligations under the transaction documents. This document cannot be reproduced except in full, without prior written approval of the Company. Any unauthorized alteration, forgery or falsification of the content or appearance of this document is unlawful and offenders may be prosecuted to the fullest extent of the law. Unless otherwise stated the results shown in this test report refer only to the sample(s) tested.

Attention: To check the authenticity of testing /inspection report & certificate, please contact us at telephone: (86-755) 8307 1443, or email: CN.Doccheck@sgs.com

Test Report

No. CANEC1419449801

Date: 28 Nov 2014

Page 2 of 8

Test Results :

Test Part Description :

Specimen No.	SGS Sample ID	Description
SN1	CAN14-194498.001	Black plastic grains

Remarks :

- (1) 1 mg/kg = 0.0001%
- (2) MDL = Method Detection Limit
- (3) ND = Not Detected (< MDL)
- (4) "-" = Not Regulated

RoHS Directive 2011/65/EU

- Test Method :
- (1)With reference to IEC 62321-5:2013, determination of Cadmium by ICP-OES.
 - (2)With reference to IEC 62321-5:2013, determination of Lead by ICP-OES.
 - (3)With reference to IEC 62321-4:2013, determination of Mercury by ICP-OES.
 - (4)With reference to IEC 62321:2008, determination of Hexavalent Chromium by Colorimetric Method using UV-Vis.
 - (5)With reference to IEC 62321:2008, determination of PBBs and PBDEs by GC-MS.

<u>Test Item(s)</u>	<u>Limit</u>	<u>Unit</u>	<u>MDL</u>	<u>001</u>
Cadmium (Cd)	100	mg/kg	2	ND
Lead (Pb)	1,000	mg/kg	2	8
Mercury (Hg)	1,000	mg/kg	2	ND
Hexavalent Chromium (CrVI)	1,000	mg/kg	2	ND
Sum of PBBs	1,000	mg/kg	-	ND
Monobromobiphenyl	-	mg/kg	5	ND
Dibromobiphenyl	-	mg/kg	5	ND
Tribromobiphenyl	-	mg/kg	5	ND
Tetrabromobiphenyl	-	mg/kg	5	ND
Pentabromobiphenyl	-	mg/kg	5	ND
Hexabromobiphenyl	-	mg/kg	5	ND
Heptabromobiphenyl	-	mg/kg	5	ND
Octabromobiphenyl	-	mg/kg	5	ND
Nonabromobiphenyl	-	mg/kg	5	ND
Decabromobiphenyl	-	mg/kg	5	ND
Sum of PBDEs	1,000	mg/kg	-	ND
Monobromodiphenyl ether	-	mg/kg	5	ND



This document is issued by the Company subject to its General Conditions of Service printed overleaf, available on request or accessible at <http://www.sgs.com/en/Terms-and-Conditions.aspx> and, for electronic format documents, subject to Terms and Conditions for Electronic Documents at <http://www.sgs.com/en/Terms-and-Conditions/Terms-e-Documents.aspx>. Attention is drawn to the limitation of liability, indemnification and jurisdiction issues defined therein. Any holder of this document is advised that information contained hereon reflects the Company's findings at the time of its intervention only and within the limits of Client's instructions, if any. The Company's sole responsibility is to its Client and this document does not exonerate parties to a transaction from exercising all their rights and obligations under the transaction documents. This document cannot be reproduced except in full, without prior written approval of the Company. Any unauthorized alteration, forgery or falsification of the content or appearance of this document is unlawful and offenders may be prosecuted to the fullest extent of the law. Unless otherwise stated the results shown in this test report refer only to the sample(s) tested.

Attention: To check the authenticity of testing /inspection report & certificate, please contact us at telephone: (86-755) 8307 1443, or email: CN.Doccheck@sgs.com

198 Kezhu Road, Sciencetech Park Guangzhou Economic & Technology Development District, Guangzhou, China 510663 t (86-20) 82155555 f (86-20) 82075113 www.sgsgroup.com.cn
中国·广州·经济技术开发区科学城科珠路198号 邮编: 510663 t (86-20) 82155555 f (86-20) 82075113 e sgs.china@sgs.com

Test Report

No. CANEC1419449801

Date: 28 Nov 2014

Page 3 of 8

<u>Test Item(s)</u>	<u>Limit</u>	<u>Unit</u>	<u>MDL</u>	<u>001</u>
Dibromodiphenyl ether	-	mg/kg	5	ND
Tribromodiphenyl ether	-	mg/kg	5	ND
Tetrabromodiphenyl ether	-	mg/kg	5	ND
Pentabromodiphenyl ether	-	mg/kg	5	ND
Hexabromodiphenyl ether	-	mg/kg	5	ND
Heptabromodiphenyl ether	-	mg/kg	5	ND
Octabromodiphenyl ether	-	mg/kg	5	ND
Nonabromodiphenyl ether	-	mg/kg	5	ND
Decabromodiphenyl ether	-	mg/kg	5	ND

Notes :

- (1) The maximum permissible limit is quoted from the directive 2011/65/EU, Annex II.

Hexabromocyclododecane (HBCDD)

Test Method : Determination of HBCDD by GC-MS based on IEC 62321:2008.

<u>Test Item(s)</u>	<u>Unit</u>	<u>MDL</u>	<u>001</u>
Hexabromocyclododecane (HBCDD)	mg/kg	10	ND

Notes :

- (1) Reference Information: Directive 2011/65/EU recasting RoHS directive 2002/95/EC:
Hexabromocyclododecane (HBCDD) is considered as a priority for risk evaluation and substance restriction.

Phthalate

Test Method : Determination of phthalates by GC-MS based on EN 14372:2004.

<u>Test Item(s)</u>	<u>CAS NO.</u>	<u>Unit</u>	<u>MDL</u>	<u>001</u>
Dibutyl Phthalate (DBP)	84-74-2	%(w/w)	0.003	ND
Benzylbutyl Phthalate (BBP)	85-68-7	%(w/w)	0.003	ND
Bis(2-ethylhexyl) Phthalate (DEHP)	117-81-7	%(w/w)	0.003	ND



This document is issued by the Company subject to its General Conditions of Service printed overleaf, available on request or accessible at <http://www.sgs.com/en/Terms-and-Conditions.aspx> and, for electronic format documents, subject to Terms and Conditions for Electronic Documents at <http://www.sgs.com/en/Terms-and-Conditions/Terms-e-Documents.aspx>. Attention is drawn to the limitation of liability, indemnification and jurisdiction issues defined therein. Any holder of this document is advised that information contained hereon reflects the Company's findings at the time of its intervention only and within the limits of Client's instructions, if any. The Company's sole responsibility is to its Client and this document does not exonerate parties to a transaction from exercising all their rights and obligations under the transaction documents. This document cannot be reproduced except in full, without prior written approval of the Company. Any unauthorized alteration, forgery or falsification of the content or appearance of this document is unlawful and offenders may be prosecuted to the fullest extent of the law. Unless otherwise stated the results shown in this test report refer only to the sample(s) tested.

Attention: To check the authenticity of testing / inspection report & certificate, please contact us at telephone: (86-755) 8307 1443, or email: CN.Doccheck@sgs.com

Notes :

- (1) Reference Information: Directive 2011/65/EU recasting RoHS directive 2002/95/EC: Bis (2-ethylhexyl) phthalate (DEHP), Butyl benzyl phthalate (BBP) and Dibutyl phthalate (DBP) are considered as a priority for risk evaluation and substance restriction.



This document is issued by the Company subject to its General Conditions of Service printed overleaf, available on request or accessible at <http://www.sgs.com/en/Terms-and-Conditions.aspx> and, for electronic format documents, subject to Terms and Conditions for Electronic Documents at <http://www.sgs.com/en/Terms-and-Conditions/Terms-e-Documents.aspx>. Attention is drawn to the limitation of liability, indemnification and jurisdiction issues defined therein. Any holder of this document is advised that information contained hereon reflects the Company's findings at the time of its intervention only and within the limits of Client's instructions, if any. The Company's sole responsibility is to its Client and this document does not exonerate parties to a transaction from exercising all their rights and obligations under the transaction documents. This document cannot be reproduced except in full, without prior written approval of the Company. Any unauthorized alteration, forgery or falsification of the content or appearance of this document is unlawful and offenders may be prosecuted to the fullest extent of the law. Unless otherwise stated the results shown in this test report refer only to the sample(s) tested.

Attention: To check the authenticity of testing /inspection report & certificate, please contact us at telephone: (86-755) 8307 1443, or email: CN.Doccheck@sgs.com

ATTACHMENTS

RoHS Testing Flow Chart

- 1) Name of the person who made testing: Bruce Xiao / Sunny Hu
- 2) Name of the person in charge of testing: Bella Wang / Cutey Yu
- 3) These samples were dissolved totally by pre-conditioning method according to below flow chart (Cr⁶⁺ and PBBs/PBDEs test method excluded).

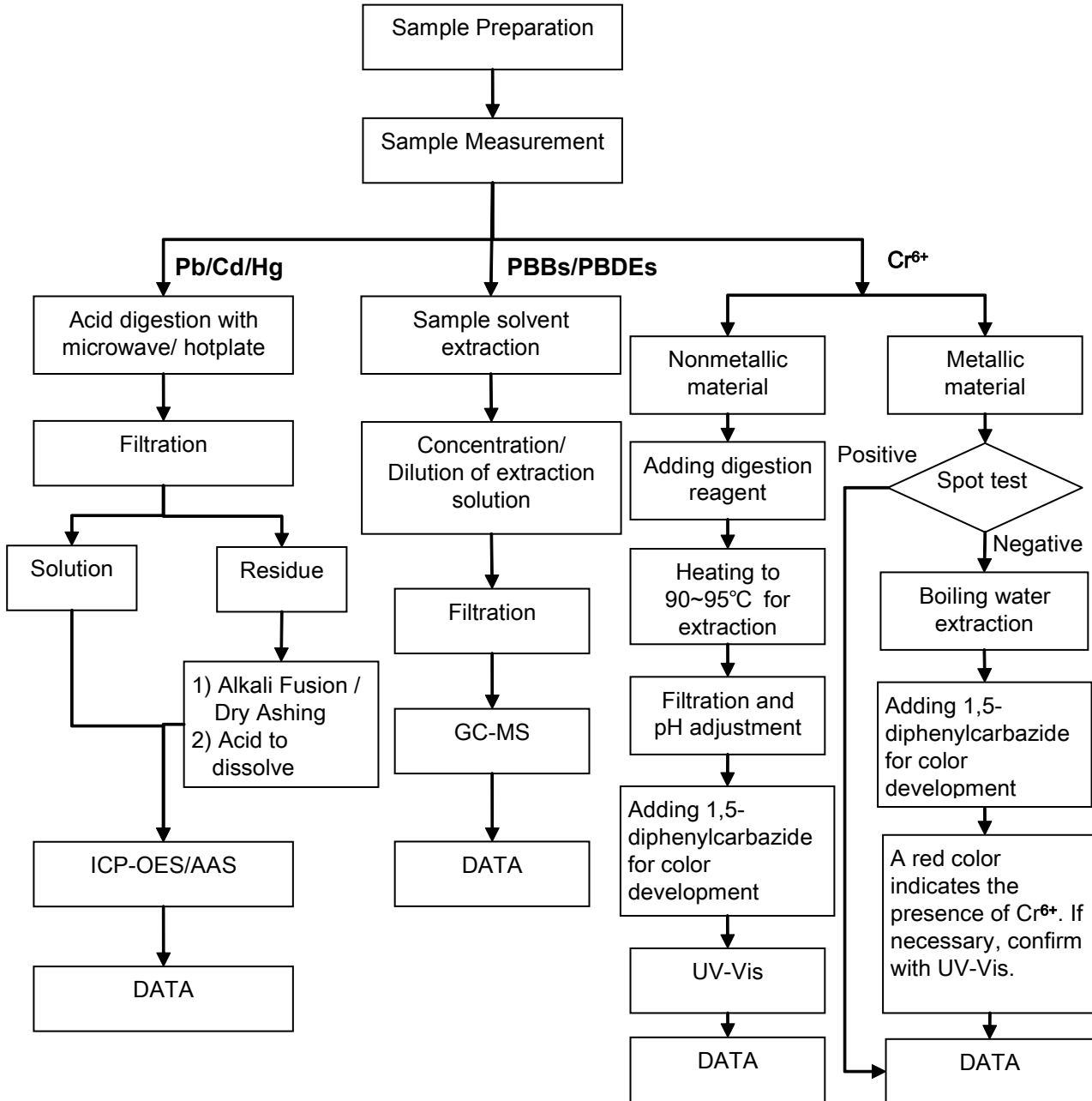

This document is issued by the Company subject to its General Conditions of Service printed overleaf, available on request or accessible at <http://www.sgs.com/en/Terms-and-Conditions.aspx> and, for electronic format documents, subject to Terms and Conditions for Electronic Documents at <http://www.sgs.com/en/Terms-and-Conditions/Terms-e-Documents.aspx>. Attention is drawn to the limitation of liability, indemnification and jurisdiction issues defined therein. Any holder of this document is advised that information contained herein reflects the Company's findings at the time of its intervention only and within the limits of Client's instructions, if any. The Company's sole responsibility is to its Client and this document does not exonerate parties to a transaction from exercising all their rights and obligations under the transaction documents. This document cannot be reproduced except in full, without prior written approval of the Company. Any unauthorized alteration, forgery or falsification of the content or appearance of this document is unlawful and offenders may be prosecuted to the fullest extent of the law. Unless otherwise stated the results shown in this test report refer only to the sample(s) tested.

Attention: To check the authenticity of testing / inspection report & certificate, please contact us at telephone: (86-755) 8307 1443, or email: CN.Doccheck@sgs.com

198 Kezhu Road, Sciencetech Park Guangzhou Economic & Technology Development District, Guangzhou, China 510663 t (86-20) 82155555 f (86-20) 82075113 www.sgs.com.cn
 中国·广州·经济技术开发区科学城科珠路198号 邮编: 510663 t (86-20) 82155555 f (86-20) 82075113 e sgs.china@sgs.com

ATTACHMENTS

HBCDD Testing Flow Chart

- 1) Name of the person who made testing: Sunny Hu
- 2) Name of the person in charge of testing: Cutey Yu

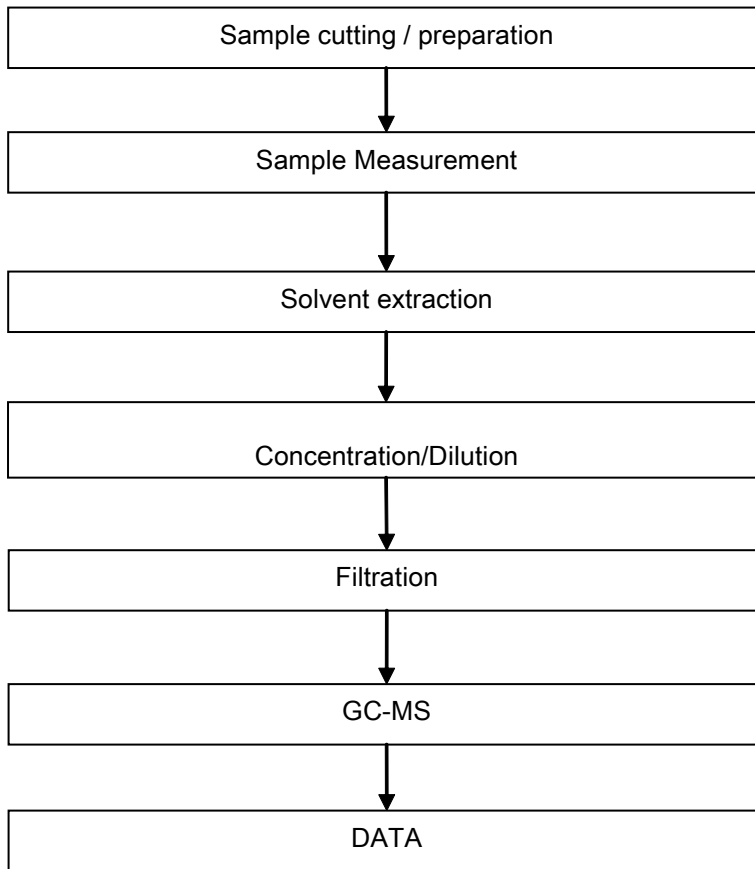

This document is issued by the Company subject to its General Conditions of Service printed overleaf, available on request or accessible at <http://www.sgs.com/en/Terms-and-Conditions.aspx> and, for electronic format documents, subject to Terms and Conditions for Electronic Documents at <http://www.sgs.com/en/Terms-and-Conditions/Terms-e-Documents.aspx>. Attention is drawn to the limitation of liability, indemnification and jurisdiction issues defined therein. Any holder of this document is advised that information contained hereon reflects the Company's findings at the time of its intervention only and within the limits of Client's instructions, if any. The Company's sole responsibility is to its Client and this document does not exonerate parties to a transaction from exercising all their rights and obligations under the transaction documents. This document cannot be reproduced except in full, without prior written approval of the Company. Any unauthorized alteration, forgery or falsification of the content or appearance of this document is unlawful and offenders may be prosecuted to the fullest extent of the law. Unless otherwise stated the results shown in this test report refer only to the sample(s) tested.

Attention: To check the authenticity of testing / inspection report & certificate, please contact us at telephone: (86-755) 8307 1443, or email: CN.Doccheck@sgs.com

198 Kezhu Road, Sciencetech Park Guangzhou Economic & Technology Development District, Guangzhou, China 510663 t (86-20) 82155555 f (86-20) 82075113 www.sgsgroup.com.cn
 中国·广州·经济技术开发区科学城科珠路198号 邮编: 510663 t (86-20) 82155555 f (86-20) 82075113 e sgs.china@sgs.com

ATTACHMENTS

Phthalates Testing Flow Chart

- 1) Name of the person who made testing: Sunny Hu
- 2) Name of the person in charge of testing: Cutey Yu

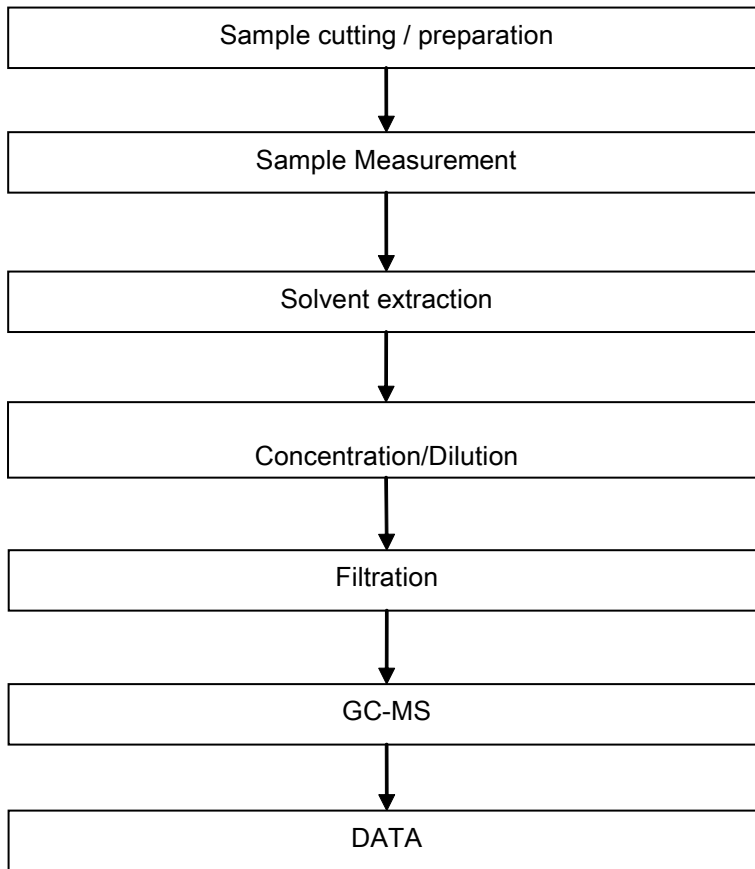

This document is issued by the Company subject to its General Conditions of Service printed overleaf, available on request or accessible at <http://www.sgs.com/en/Terms-and-Conditions.aspx> and, for electronic format documents, subject to Terms and Conditions for Electronic Documents at <http://www.sgs.com/en/Terms-and-Conditions/Terms-e-Documents.aspx>. Attention is drawn to the limitation of liability, indemnification and jurisdiction issues defined therein. Any holder of this document is advised that information contained hereon reflects the Company's findings at the time of its intervention only and within the limits of Client's instructions, if any. The Company's sole responsibility is to its Client and this document does not exonerate parties to a transaction from exercising all their rights and obligations under the transaction documents. This document cannot be reproduced except in full, without prior written approval of the Company. Any unauthorized alteration, forgery or falsification of the content or appearance of this document is unlawful and offenders may be prosecuted to the fullest extent of the law. Unless otherwise stated the results shown in this test report refer only to the sample(s) tested.

Attention: To check the authenticity of testing / inspection report & certificate, please contact us at telephone: (86-755) 8307 1443, or email: CN.Doccheck@sgs.com

198 Kezhu Road, Sciencetech Park Guangzhou Economic & Technology Development District, Guangzhou, China 510663 t (86-20) 82155555 f (86-20) 82075113 www.sgs.com.cn
 中国·广州·经济技术开发区科学城科珠路198号 邮编: 510663 t (86-20) 82155555 f (86-20) 82075113 e sgs.china@sgs.com

Sample photo:



SGS authenticate the photo on original report only

*** End of Report ***

2014090938Z
Testing
CNAS L0599

Test Report

No. SHAEC1500322205

Date: 15 Jan 2015

Page 1 of 15

HANG ZHOU TOKA INK CHEMICAL.CO.,LTD

NO.2,THE 5TH AVENUE(SOUTH),BAIYANG JIE DAO,HANGZHOU ECONOMIC&TECHNOLOGICAL DEVELOPMENT AREA

The following sample(s) was/were submitted and identified on behalf of the clients as : UV NH BLACK

SGS Job No. : SP15-000403 - SH

Date of Sample Received : 07 Jan 2015

Testing Period : 07 Jan 2015 - 13 Jan 2015

Test Requested : Selected test(s) as requested by client.

Test Method : Please refer to next page(s).

Test Results : Please refer to next page(s).

Conclusion : Based on the performed tests on submitted sample(s), the results of Lead, Mercury, Cadmium, Hexavalent chromium, Polybrominated biphenyls (PBBs), Polybrominated diphenyl ethers (PBDEs) comply with the limits as set by RoHS Directive 2011/65/EU Annex II; recasting 2002/95/EC.

Signed for and on behalf of
SGS-CSTC Standards Technical Services (Shanghai) Co., Ltd.

Lisa Fan

Approved Signatory



This document is issued by the Company subject to its General Conditions of Service printed overleaf, available on request or accessible at <http://www.sgs.com/en/Terms-and-Conditions.aspx> and, for electronic format documents, subject to Terms and Conditions for Electronic Documents at <http://www.sgs.com/en/Terms-and-Conditions/Terms-e-Document.aspx>. Attention is drawn to the limitation of liability, indemnification and jurisdiction issues defined therein. Any holder of this document is advised that information contained hereon reflects the Company's findings at the time of its intervention only and within the limits of Client's instructions, if any. The Company's sole responsibility is to its Client and this document does not exonerate parties to a transaction from exercising all their rights and obligations under the transaction documents. This document cannot be reproduced except in full, without prior written approval of the Company. Any unauthorized alteration, forgery or falsification of the content or appearance of this document is unlawful and offenders may be prosecuted to the fullest extent of the law. Unless otherwise stated the results shown in this test report refer only to the sample(s) tested.

Attention: To check the authenticity of testing /inspection report & certificate, please contact us at telephone: (86-755) 8307 1443, or email: CN_Doccheck@sgs.com

SGS-CSTC Standards Technical Services (Shanghai) Co., Ltd.
Testing Center (Shanghai) Co., Ltd.

3rd Building, No. 889 Yishan Road Xuhui District, Shanghai China 200233
中国·上海·徐汇区宜山路889号3号楼 邮编: 200233

t E&E (86-21) 61402553 f E&E (86-21) 64953679 www.sgsgroup.com.cn
HL: (86-21) 61402594 HL: (86-21) 54500353 e sgs.china@sgs.com

Member of the SGS Group (SGS SA)

Test Report

No. SHAEC1500322205

Date: 15 Jan 2015

Page 2 of 15

Test Results :

Test Part Description :

Specimen No.	SGS Sample ID	Description
SN1	SHA15-003222.005	Black mud

Remarks :

- (1) 1 mg/kg = 0.0001%
- (2) MDL = Method Detection Limit
- (3) ND = Not Detected (< MDL)
- (4) "-" = Not Regulated

RoHS Directive 2011/65/EU

- Test Method :
- (1) With reference to IEC 62321-5:2013, determination of Cadmium by ICP-OES.
 - (2) With reference to IEC 62321-5:2013, determination of Lead by ICP-OES.
 - (3) With reference to IEC 62321-4:2013, determination of Mercury by ICP-OES.
 - (4) With reference to IEC 62321:2008, determination of Hexavalent Chromium by Colorimetric Method using UV-Vis.
 - (5) With reference to IEC 62321:2008, determination of PBBs and PBDEs by GC-MS.

Test Item(s)	Limit	Unit	MDL	005
Cadmium (Cd)	100	mg/kg	2	ND
Lead (Pb)	1000	mg/kg	2	ND
Mercury (Hg)	1000	mg/kg	2	ND
Hexavalent Chromium (Cr(VI))	1000	mg/kg	2	ND
Sum of PBBs	1000	mg/kg	-	ND
Monobromobiphenyl	-	mg/kg	5	ND
Dibromobiphenyl	-	mg/kg	5	ND
Tribromobiphenyl	-	mg/kg	5	ND
Tetrabromobiphenyl	-	mg/kg	5	ND
Pentabromobiphenyl	-	mg/kg	5	ND
Hexabromobiphenyl	-	mg/kg	5	ND
Heptabromobiphenyl	-	mg/kg	5	ND
Octabromobiphenyl	-	mg/kg	5	ND
Nonabromobiphenyl	-	mg/kg	5	ND
Decabromobiphenyl	-	mg/kg	5	ND
Sum of PBDEs	1000	mg/kg	-	ND
Monobromodiphenyl ether	-	mg/kg	5	ND



This document is issued by the Company subject to its General Conditions of Service printed overleaf, available on request or accessible at <http://www.sgs.com/en/Terms-and-Conditions.aspx> and, for electronic format documents, subject to Terms and Conditions for Electronic Documents at <http://www.sgs.com/en/Terms-and-Conditions/Terms-e-Document.aspx>. Attention is drawn to the limitation of liability, indemnification and jurisdiction issues defined therein. Any holder of this document is advised that information contained hereon reflects the Company's findings at the time of its intervention only and within the limits of Client's instructions, if any. The Company's sole responsibility is to its Client and this document does not exonerate parties to a transaction from exercising all their rights and obligations under the transaction documents. This document cannot be reproduced except in full, without prior written approval of the Company. Any unauthorized alteration, forgery or falsification of the content or appearance of this document is unlawful and offenders may be prosecuted to the fullest extent of the law. Unless otherwise stated the results shown in this test report refer only to the sample(s) tested.

Attention: To check the authenticity of testing / inspection report & certificate, please contact us at telephone: (86-755) 8307 1443, or email: CN.Doccheck@sgs.com

Test Report

No. SHAEC1500322205

Date: 15 Jan 2015

Page 3 of 15

<u>Test Item(s)</u>	<u>Limit</u>	<u>Unit</u>	<u>MDL</u>	<u>005</u>
Dibromodiphenyl ether	-	mg/kg	5	ND
Tribromodiphenyl ether	-	mg/kg	5	ND
Tetrabromodiphenyl ether	-	mg/kg	5	ND
Pentabromodiphenyl ether	-	mg/kg	5	ND
Hexabromodiphenyl ether	-	mg/kg	5	ND
Heptabromodiphenyl ether	-	mg/kg	5	ND
Octabromodiphenyl ether	-	mg/kg	5	ND
Nonabromodiphenyl ether	-	mg/kg	5	ND
Decabromodiphenyl ether	-	mg/kg	5	ND

Notes :

- (1) The maximum permissible limit is quoted from the directive 2011/65/EU, Annex II

Halogen

Test Method : With reference to EN 14582: 2007, analysis was performed by Ion Chromatograph (IC).

<u>Test Item(s)</u>	<u>Unit</u>	<u>MDL</u>	<u>005</u>
Fluorine (F)	mg/kg	50	ND
Chlorine (Cl)	mg/kg	50	365
Bromine (Br)	mg/kg	50	ND
Iodine (I)	mg/kg	50	ND

Tetrabromobisphenol A (TBBP-A)

Test Method : With reference to US EPA 3540C: 1996, analysis was performed by GC-MS.

<u>Test Item(s)</u>	<u>Unit</u>	<u>MDL</u>	<u>005</u>
Tetrabromobisphenol A (TBBP-A)	mg/kg	10	ND

Hexabromocyclododecane (HBCDD)*

Test Method : Determination of HBCDD by GC-MS based on IEC 62321:2008.

<u>Test Item(s)</u>	<u>Unit</u>	<u>MDL</u>	<u>005</u>
Hexabromocyclododecane (HBCDD)	mg/kg	10	ND



This document is issued by the Company subject to its General Conditions of Service printed overleaf, available on request or accessible at <http://www.sgs.com/en/Terms-and-Conditions.aspx> and, for electronic format documents, subject to Terms and Conditions for Electronic Documents at <http://www.sgs.com/en/Terms-and-Conditions/Terms-e-Documents.aspx>. Attention is drawn to the limitation of liability, indemnification and jurisdiction issues defined therein. Any holder of this document is advised that information contained hereon reflects the Company's findings at the time of its intervention only and within the limits of Client's instructions, if any. The Company's sole responsibility is to its Client and this document does not exonerate parties to a transaction from exercising all their rights and obligations under the transaction documents. This document cannot be reproduced except in full, without prior written approval of the Company. Any unauthorized alteration, forgery or falsification of the content or appearance of this document is unlawful and offenders may be prosecuted to the fullest extent of the law. Unless otherwise stated the results shown in this test report refer only to the sample(s) tested.

Attention: To check the authenticity of testing / inspection report & certificate, please contact us at telephone: (86-755) 8307 1443, or email: CN.Doccheck@sgs.com



Test Report

No. SHAEC1500322205

Date: 15 Jan 2015

Page 4 of 15

Notes :

- (1) Reference Information: Directive 2011/65/EU recasting RoHS directive 2002/95/EC: Hexabromocyclododecane (HBCDD) is considered as a priority for risk evaluation and substance restriction.
- (2) Test item marked"" in this report are not included in CNAS/CMA Accredited Scope for our laboratory

PVC (Polyvinyl chloride)*

Test Method : In-house method (SHTC-CHEM-SOP-115-T), analysis was performed by FTIR/HATR.

Test Item(s)	CAS NO.	Unit	MDL	005
PVC	9002-86-2	-	-	Negative

Notes :

- (1) Negative=Undetectable,Positive=Detectable
- (2) Test item marked"" in this report are not included in CNAS/CMA Accredited Scope for our laboratory

Phthalates

Test Method : Determination of phthalates by GC-MS based on EN 14372:2004.

Test Item(s)	CAS NO.	Unit	MDL	005
Dibutyl Phthalate (DBP)	84-74-2	%	0.003	ND
Benzylbutyl Phthalate (BBP)	85-68-7	%	0.003	ND
Bis-(2-ethylhexyl) Phthalate (DEHP)	117-81-7	%	0.003	ND
Di-n-octyl Phthalate (DNOP)	117-84-0	%	0.003	ND
Diisononyl Phthalate (DINP)	28553-12-0 /68515-48-0	%	0.01	ND
Diisodecyl Phthalate (DIDP)	26761-40-0 /68515-49-1	%	0.01	ND
Diisobutyl Phthalate (DIBP)*	84-69-5	%	0.003	ND
Dimethyl Phthalate (DMP)*	131-11-3	%	0.003	ND
Di-n-hexyl Phthalate (DnHP)*	84-75-3	%	0.003	ND
Diethyl Phthalate (DEP)*	84-66-2	%	0.003	ND

Notes :

- (1) Reference Information: Directive 2011/65/EU recasting RoHS directive 2002/95/EC: Bis (2-ethylhexyl) phthalate (DEHP), Butyl benzyl phthalate (BBP) and Dibutyl phthalate (DBP) are considered as a priority for risk evaluation and substance restriction.
- (2) Test item marked"" in this report are not included in CNAS/CMA Accredited Scope for our laboratory



This document is issued by the Company subject to its General Conditions of Service printed overleaf, available on request or accessible at <http://www.sgs.com/en/Terms-and-Conditions.aspx> and, for electronic format documents, subject to Terms and Conditions for Electronic Documents at <http://www.sgs.com/en/Terms-and-Conditions/Terms-e-Documents.aspx>. Attention is drawn to the limitation of liability, indemnification and jurisdiction issues defined therein. Any holder of this document is advised that information contained hereon reflects the Company's findings at the time of its intervention only and within the limits of Client's instructions, if any. The Company's sole responsibility is to its Client and this document does not exonerate parties to a transaction from exercising all their rights and obligations under the transaction documents. This document cannot be reproduced except in full, without prior written approval of the Company. Any unauthorized alteration, forgery or falsification of the content or appearance of this document is unlawful and offenders may be prosecuted to the fullest extent of the law. Unless otherwise stated the results shown in this test report refer only to the sample(s) tested.

Attention: To check the authenticity of testing /inspection report & certificate, please contact us at telephone: (86-755) 8307 1443, or email: CN.Doccheck@sgs.com

SGS-Standard Technical Services (Shanghai) Co., Ltd.
Testing Center (National Laboratory)

3rd Building, No. 889 Yishan Road Xuhui District, Shanghai China 200233
中国·上海·徐汇区宜山路889号3号楼 邮编: 200233

t E&E (86-21) 61402553 f E&E (86-21) 64953679 www.sgsgroup.com.cn
HL: (86-21) 61402594 HL: (86-21) 54500353 e sgs.china@sgs.com

Test Report

No. SHAEC1500322205

Date: 15 Jan 2015

Page 5 of 15

PFOS (Perfluorooctane Sulfonates) and PFOA (Perfluorooctanoic Acid)

Test Method : With reference to US EPA 3550C: 2007, analysis was performed by HPLC-MS.

<u>Test Item(s)</u>	<u>Limit</u>	<u>Unit</u>	<u>MDL</u>	<u>005</u>
Perfluorooctane Sulfonates (PFOS) and related Acid, Metal Salt and Amide	10	mg/kg	10	ND
Perfluorooctanoic Acid (PFOA)	-	mg/kg	10	ND

Notes :

Max. limit specified by commission regulation (EU) No. 757/2010 amending regulation (EC) No 850/2004.

Polycyclic aromatic hydrocarbons (PAHs)

Test Method : With reference to ZEK 01.4-08 of German ZLS and its amendments, analysis was performed by GC-MS.

<u>Test Item(s)</u>	<u>Unit</u>	<u>MDL</u>	<u>005</u>
Sum of 18 PAHs	mg/kg	-	1.7
Naphthalene(NAP)	mg/kg	0.1	1.7
Acenaphthylene(ANY)	mg/kg	0.1	ND
Acenaphthene(ANA)	mg/kg	0.1	ND
Fluorene(FLU)	mg/kg	0.1	ND
Phenanthrene(PHE)	mg/kg	0.1	ND
Anthracene(ANT)	mg/kg	0.1	ND
Fluoranthene(FLT)	mg/kg	0.1	ND
Pyrene(PYR)	mg/kg	0.1	ND
Benzo(a)anthracene(BaA)	mg/kg	0.1	ND
Chrysene(CHR)	mg/kg	0.1	ND
Benzo(b)fluoranthene(BbF) and Benzo(j)fluoranthene(BjF)	mg/kg	0.1	ND
Benzo(k)fluoranthene(BkF)	mg/kg	0.1	ND
Benzo(a)pyrene(BaP)	mg/kg	0.1	ND
Benzo(e)pyrene(BeP)	mg/kg	0.1	ND
Indeno(1,2,3-c,d)pyrene(IPY)	mg/kg	0.1	ND
Dibenzo(a,h)anthracene(DBA)	mg/kg	0.1	ND
Benzo(g,h,i)perylene(BPE)	mg/kg	0.1	ND

Notes :

Above 8 PAHs(BaA,CHR,BbF,BjF,BkF,BeP,BaP,DBA) are listed in Commission Regulation (EU) No 1272/2013 amending Annex XVII to Regulation (EC) No 1907/2006.



This document is issued by the Company subject to its General Conditions of Service printed overleaf, available on request or accessible at <http://www.sgs.com/en/Terms-and-Conditions.aspx> and, for electronic format documents, subject to Terms and Conditions for Electronic Documents at <http://www.sgs.com/en/Terms-and-Conditions/Terms-e-Documents.aspx>. Attention is drawn to the limitation of liability, indemnification and jurisdiction issues defined therein. Any holder of this document is advised that information contained hereon reflects the Company's findings at the time of its intervention only and within the limits of Client's instructions, if any. The Company's sole responsibility is to its Client and this document does not exonerate parties to a transaction from exercising all their rights and obligations under the transaction documents. This document cannot be reproduced except in full, without prior written approval of the Company. Any unauthorized alteration, forgery or falsification of the content or appearance of this document is unlawful and offenders may be prosecuted to the fullest extent of the law. Unless otherwise stated the results shown in this test report refer only to the sample(s) tested.

Attention: To check the authenticity of testing / inspection report & certificate, please contact us at telephone: (86-755) 8307 1443, or email: CN.Doccheck@sgs.com

Test Report

No. SHAEC1500322205

Date: 15 Jan 2015

Page 6 of 15

(1) In order to protect the health of consumers from the risk arising from exposure to PAHs in articles, limits on the PAH content in the accessible plastic or rubber parts of articles should be set, and the placing on the market of articles containing any of the PAHs in concentrations greater than 1 mg/kg in those parts should be prohibited.

(2) Taking into account the vulnerability of children a lower limit value should be established. Therefore the placing on the market of toys and childcare articles, containing any of the PAHs in concentrations greater than 0,5 mg/kg in their accessible plastic or rubber parts, should be prohibited.

ZEK 01.4-08: Restraining maximum values for products

Parameter	Category 1	Category 2	Category 3
	Material indented to be put in the mouth or material for toys with normal skin contact for children aged < 36 months	Materials those are not included in Category 1, with predictable contact with the skin longer than 30 s. (long-term skin contact).	Materials those are not included in Category 1 or 2, with predictable skin contact up to 30 s (short-term skin contact).
Benzo(a)pyrene (mg/kg)	<0.2**	1	20
Sum of 18 PAHs (mg/kg)*	<0.2**	10	200

Notes:

- * = Only PAH substances >0.1 mg/kg are taken into account while calculating the sum of PAHs
- ** = In case that the maximum values exceed the limits of category 1, but are within the limits of category 2, one may confirm the suitability of the tested material which is indented to be put in the mouth by additional specific migration tests of PAH components based on DIN EN 1186ff and §64 LFGB 80.30-1. The conclusion of the migration test results must be made based on food law criteria.

Remark: Result shown is of the total weight of wet sample.



This document is issued by the Company subject to its General Conditions of Service printed overleaf, available on request or accessible at <http://www.sgs.com/en/Terms-and-Conditions.aspx> and, for electronic format documents, subject to Terms and Conditions for Electronic Documents at <http://www.sgs.com/en/Terms-and-Conditions/Terms-e-Documents.aspx>. Attention is drawn to the limitation of liability, indemnification and jurisdiction issues defined therein. Any holder of this document is advised that information contained hereon reflects the Company's findings at the time of its intervention only and within the limits of Client's instructions, if any. The Company's sole responsibility is to its Client and this document does not exonerate parties to a transaction from exercising all their rights and obligations under the transaction documents. This document cannot be reproduced except in full, without prior written approval of the Company. Any unauthorized alteration, forgery or falsification of the content or appearance of this document is unlawful and offenders may be prosecuted to the fullest extent of the law. Unless otherwise stated the results shown in this test report refer only to the sample(s) tested.

Attention: To check the authenticity of testing / inspection report & certificate, please contact us at telephone: (86-755) 8307 1443, or email: CN.Doccheck@sgs.com

ATTACHMENTS

RoHS Testing Flow Chart

- 1) Name of the person who made testing: Bob Zhang/Gary Xu/Stone Chen/Sunny Qin
- 2) Name of the person in charge of testing: Jan Shi/Summer Jin/Jessy Huang
- 3) These samples were dissolved totally by pre-conditioning method according to below flow chart. (Cr⁶⁺ and PBBs/PBDEs test method excluded)

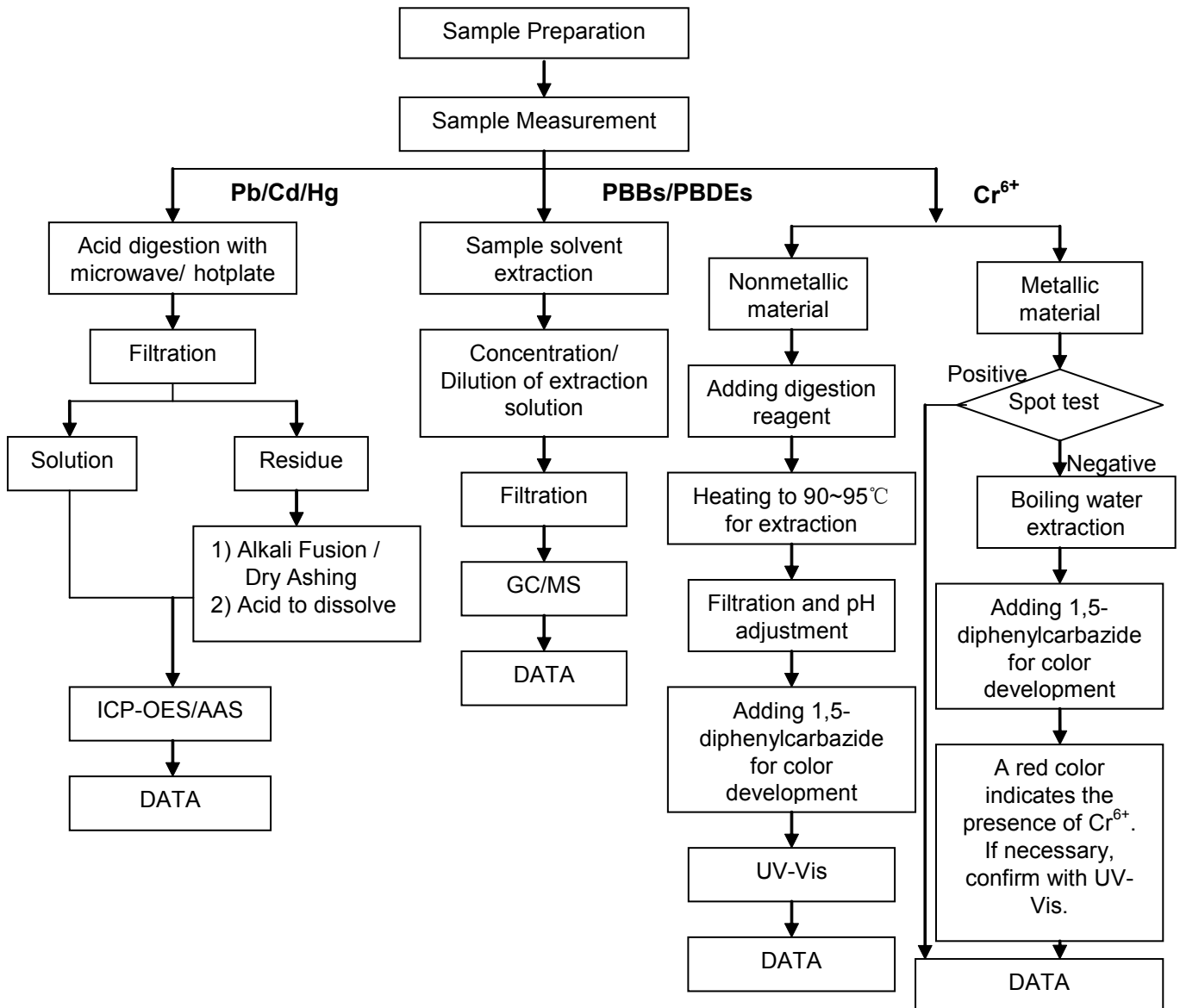

This document is issued by the Company subject to its General Conditions of Service printed overleaf, available on request or accessible at <http://www.sgs.com/en/Terms-and-Conditions.aspx> and, for electronic format documents, subject to Terms and Conditions for Electronic Documents at <http://www.sgs.com/en/Terms-and-Conditions/Terms-e-Documents.aspx>. Attention is drawn to the limitation of liability, indemnification and jurisdiction issues defined therein. Any holder of this document is advised that information contained herein reflects the Company's findings at the time of its intervention only and within the limits of Client's instructions, if any. The Company's sole responsibility is to its Client and this document does not exonerate parties to a transaction from exercising all their rights and obligations under the transaction documents. This document cannot be reproduced except in full, without prior written approval of the Company. Any unauthorized alteration, forgery or falsification of the content or appearance of this document is unlawful and offenders may be prosecuted to the fullest extent of the law. Unless otherwise stated the results shown in this test report refer only to the sample(s) tested.

Attention: To check the authenticity of testing / inspection report & certificate, please contact us at telephone: (86-755) 8307 1443, or email: CN.Doccheck@sgs.com

ATTACHMENTS

Phthalates Testing Flow Chart

- 1) Name of the person who made testing: Sherlock Gao
- 2) Name of the person in charge of testing: Myra Ma

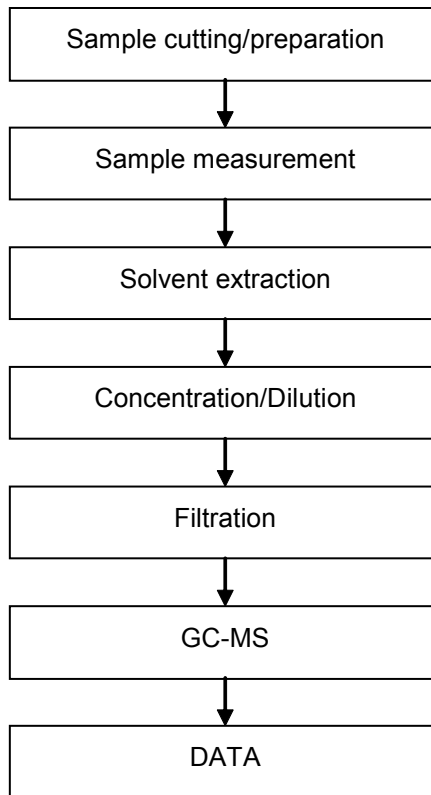

This document is issued by the Company subject to its General Conditions of Service printed overleaf, available on request or accessible at <http://www.sgs.com/en/Terms-and-Conditions.aspx> and, for electronic format documents, subject to Terms and Conditions for Electronic Documents at <http://www.sgs.com/en/Terms-and-Conditions/Terms-e-Documents.aspx>. Attention is drawn to the limitation of liability, indemnification and jurisdiction issues defined therein. Any holder of this document is advised that information contained hereon reflects the Company's findings at the time of its intervention only and within the limits of Client's instructions, if any. The Company's sole responsibility is to its Client and this document does not exonerate parties to a transaction from exercising all their rights and obligations under the transaction documents. This document cannot be reproduced except in full, without prior written approval of the Company. Any unauthorized alteration, forgery or falsification of the content or appearance of this document is unlawful and offenders may be prosecuted to the fullest extent of the law. Unless otherwise stated the results shown in this test report refer only to the sample(s) tested.

Attention: To check the authenticity of testing /inspection report & certificate, please contact us at telephone: (86-755) 8307 1443, or email: CN.Doccheck@sgs.com

ATTACHMENTS

HBCDD Testing Flow Chart

- 1) Name of the person who made testing: Gary Xu
- 2) Name of the person in charge of testing: Jessy Huang

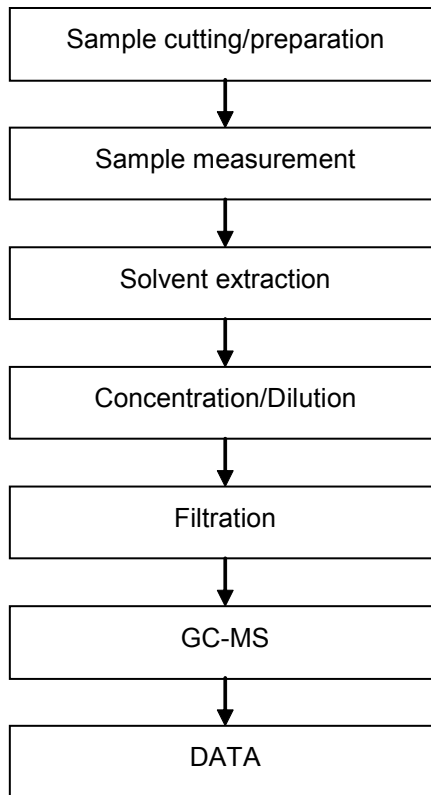

This document is issued by the Company subject to its General Conditions of Service printed overleaf, available on request or accessible at <http://www.sgs.com/en/Terms-and-Conditions.aspx> and, for electronic format documents, subject to Terms and Conditions for Electronic Documents at <http://www.sgs.com/en/Terms-and-Conditions/Terms-e-Document.aspx>. Attention is drawn to the limitation of liability, indemnification and jurisdiction issues defined therein. Any holder of this document is advised that information contained hereon reflects the Company's findings at the time of its intervention only and within the limits of Client's instructions, if any. The Company's sole responsibility is to its Client and this document does not exonerate parties to a transaction from exercising all their rights and obligations under the transaction documents. This document cannot be reproduced except in full, without prior written approval of the Company. Any unauthorized alteration, forgery or falsification of the content or appearance of this document is unlawful and offenders may be prosecuted to the fullest extent of the law. Unless otherwise stated the results shown in this test report refer only to the sample(s) tested.

Attention: To check the authenticity of testing /inspection report & certificate, please contact us at telephone: (86-755) 8307 1443, or email: CN.Doccheck@sgs.com

ATTACHMENTS

Halogen Testing (oxygen bomb) Flow Chart

- 1) Name of the person who made testing: Sisily Yin
- 2) Name of the person in charge of testing: Linda Li

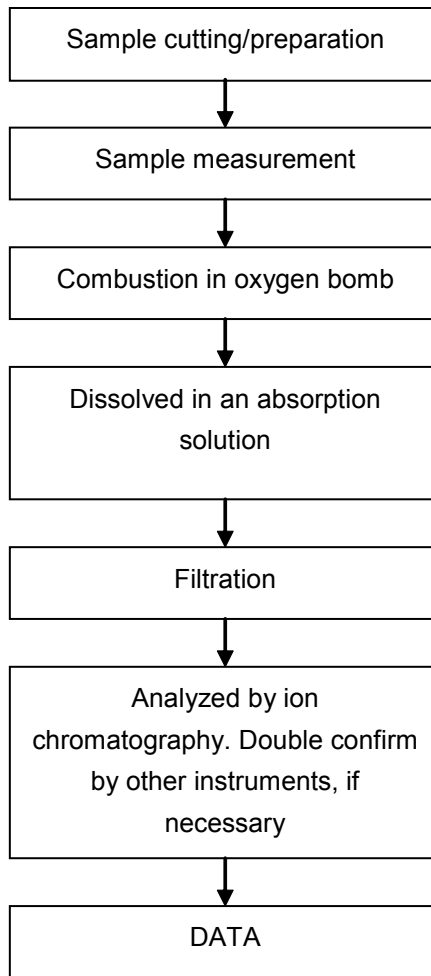

This document is issued by the Company subject to its General Conditions of Service printed overleaf, available on request or accessible at <http://www.sgs.com/en/Terms-and-Conditions.aspx> and, for electronic format documents, subject to Terms and Conditions for Electronic Documents at <http://www.sgs.com/en/Terms-and-Conditions/Terms-e-Document.aspx>. Attention is drawn to the limitation of liability, indemnification and jurisdiction issues defined therein. Any holder of this document is advised that information contained hereon reflects the Company's findings at the time of its intervention only and within the limits of Client's instructions, if any. The Company's sole responsibility is to its Client and this document does not exonerate parties to a transaction from exercising all their rights and obligations under the transaction documents. This document cannot be reproduced except in full, without prior written approval of the Company. Any unauthorized alteration, forgery or falsification of the content or appearance of this document is unlawful and offenders may be prosecuted to the fullest extent of the law. Unless otherwise stated the results shown in this test report refer only to the sample(s) tested.

Attention: To check the authenticity of testing / inspection report & certificate, please contact us at telephone: (86-755) 8307 1443, or email: CN.Doccheck@sgs.com

ATTACHMENTS

PFOS/PFOA Testing Flow Chart

- 1) Name of the person who made testing: Jane Yang
- 2) Name of the person in charge of testing: Myra Ma

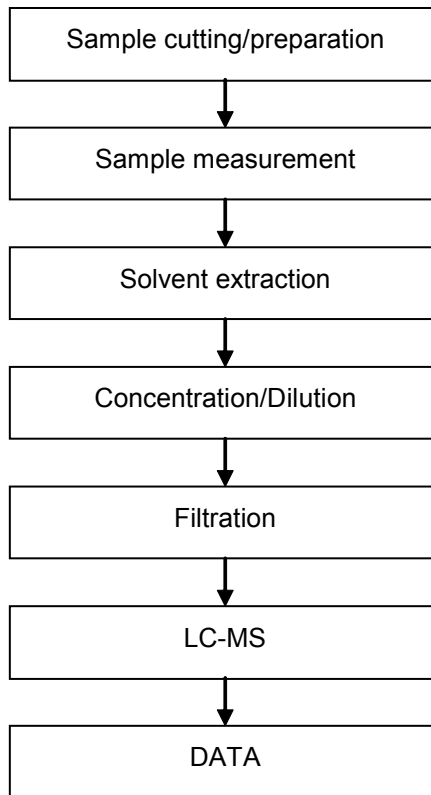

This document is issued by the Company subject to its General Conditions of Service printed overleaf, available on request or accessible at <http://www.sgs.com/en/Terms-and-Conditions.aspx> and, for electronic format documents, subject to Terms and Conditions for Electronic Documents at <http://www.sgs.com/en/Terms-and-Conditions/Terms-e-Document.aspx>. Attention is drawn to the limitation of liability, indemnification and jurisdiction issues defined therein. Any holder of this document is advised that information contained hereon reflects the Company's findings at the time of its intervention only and within the limits of Client's instructions, if any. The Company's sole responsibility is to its Client and this document does not exonerate parties to a transaction from exercising all their rights and obligations under the transaction documents. This document cannot be reproduced except in full, without prior written approval of the Company. Any unauthorized alteration, forgery or falsification of the content or appearance of this document is unlawful and offenders may be prosecuted to the fullest extent of the law. Unless otherwise stated the results shown in this test report refer only to the sample(s) tested.

Attention: To check the authenticity of testing /inspection report & certificate, please contact us at telephone: (86-755) 8307 1443, or email: CN.Doccheck@sgs.com

ATTACHMENTS

TBBP-A Testing Flow Chart

- 1) Name of the person who made testing: Gary Xu
- 2) Name of the person in charge of testing: Jessy Huang

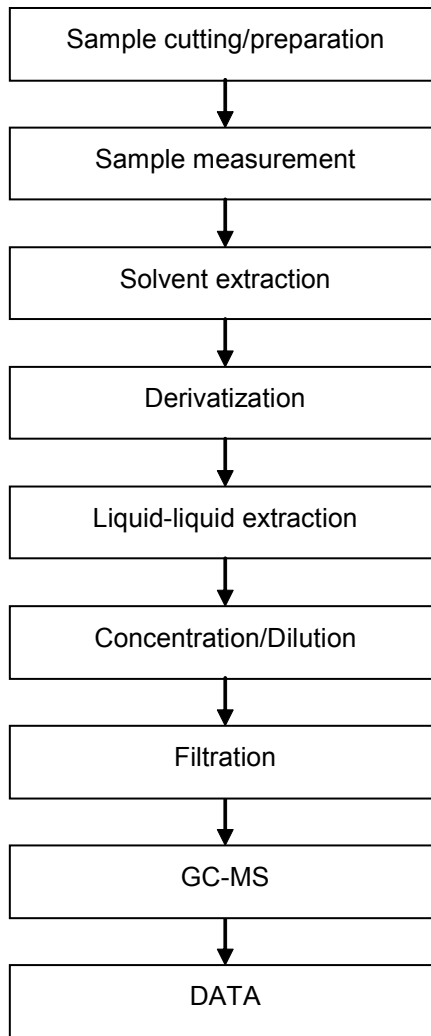

This document is issued by the Company subject to its General Conditions of Service printed overleaf, available on request or accessible at <http://www.sgs.com/en/Terms-and-Conditions.aspx> and, for electronic format documents, subject to Terms and Conditions for Electronic Documents at <http://www.sgs.com/en/Terms-and-Conditions/Terms-e-Document.aspx>. Attention is drawn to the limitation of liability, indemnification and jurisdiction issues defined therein. Any holder of this document is advised that information contained hereon reflects the Company's findings at the time of its intervention only and within the limits of Client's instructions, if any. The Company's sole responsibility is to its Client and this document does not exonerate parties to a transaction from exercising all their rights and obligations under the transaction documents. This document cannot be reproduced except in full, without prior written approval of the Company. Any unauthorized alteration, forgery or falsification of the content or appearance of this document is unlawful and offenders may be prosecuted to the fullest extent of the law. Unless otherwise stated the results shown in this test report refer only to the sample(s) tested.

Attention: To check the authenticity of testing /inspection report & certificate, please contact us at telephone: (86-755) 8307 1443, or email: CN.Doccheck@sgs.com

ATTACHMENTS

PAHs Testing Flow Chart

- 1) Name of the person who made testing: Lisa Duan
- 2) Name of the person in charge of testing: Jessy Huang

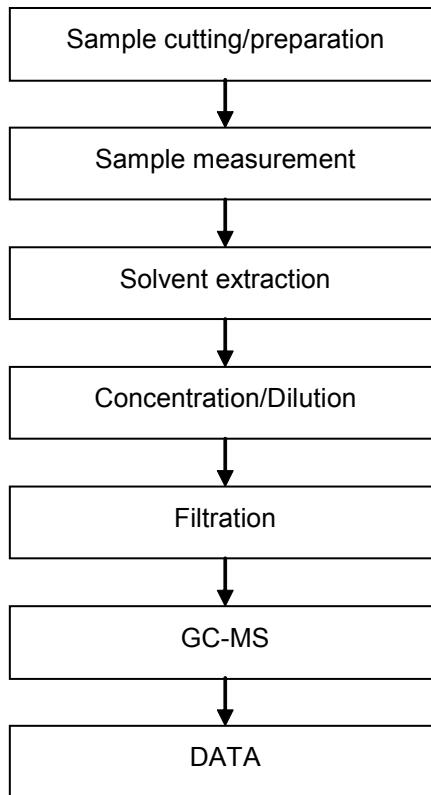

This document is issued by the Company subject to its General Conditions of Service printed overleaf, available on request or accessible at <http://www.sgs.com/en/Terms-and-Conditions.aspx> and, for electronic format documents, subject to Terms and Conditions for Electronic Documents at <http://www.sgs.com/en/Terms-and-Conditions/Terms-e-Document.aspx>. Attention is drawn to the limitation of liability, indemnification and jurisdiction issues defined therein. Any holder of this document is advised that information contained hereon reflects the Company's findings at the time of its intervention only and within the limits of Client's instructions, if any. The Company's sole responsibility is to its Client and this document does not exonerate parties to a transaction from exercising all their rights and obligations under the transaction documents. This document cannot be reproduced except in full, without prior written approval of the Company. Any unauthorized alteration, forgery or falsification of the content or appearance of this document is unlawful and offenders may be prosecuted to the fullest extent of the law. Unless otherwise stated the results shown in this test report refer only to the sample(s) tested.

Attention: To check the authenticity of testing /inspection report & certificate, please contact us at telephone: (86-755) 8307 1443, or email: CN.Doccheck@sgs.com

ATTACHMENTS

PVC Testing Flow Chart

- 1) Name of the person who made testing: Sally Liang
- 2) Name of the person in charge of testing: Linda Li

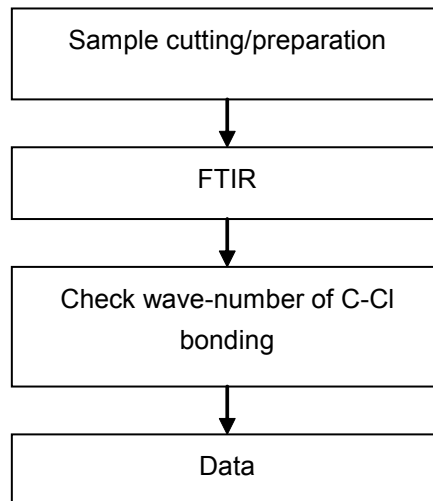

This document is issued by the Company subject to its General Conditions of Service printed overleaf, available on request or accessible at <http://www.sgs.com/en/Terms-and-Conditions.aspx> and, for electronic format documents, subject to Terms and Conditions for Electronic Documents at <http://www.sgs.com/en/Terms-and-Conditions/Terms-e-Document.aspx>. Attention is drawn to the limitation of liability, indemnification and jurisdiction issues defined therein. Any holder of this document is advised that information contained hereon reflects the Company's findings at the time of its intervention only and within the limits of Client's instructions, if any. The Company's sole responsibility is to its Client and this document does not exonerate parties to a transaction from exercising all their rights and obligations under the transaction documents. This document cannot be reproduced except in full, without prior written approval of the Company. Any unauthorized alteration, forgery or falsification of the content or appearance of this document is unlawful and offenders may be prosecuted to the fullest extent of the law. Unless otherwise stated the results shown in this test report refer only to the sample(s) tested.

Attention: To check the authenticity of testing / inspection report & certificate, please contact us at telephone: (86-755) 8307 1443, or email: CN.Doccheck@sgs.com

Test Report

No. SHAEC1500322205

Date: 15 Jan 2015

Page 15 of 15

Sample photo:



SGS authenticate the photo on original report only

*** End of Report ***



This document is issued by the Company subject to its General Conditions of Service printed overleaf, available on request or accessible at <http://www.sgs.com/en/Terms-and-Conditions.aspx> and, for electronic format documents, subject to Terms and Conditions for Electronic Documents at <http://www.sgs.com/en/Terms-and-Conditions/Terms-e-Document.aspx>. Attention is drawn to the limitation of liability, indemnification and jurisdiction issues defined therein. Any holder of this document is advised that information contained hereon reflects the Company's findings at the time of its intervention only and within the limits of Client's instructions, if any. The Company's sole responsibility is to its Client and this document does not exonerate parties to a transaction from exercising all their rights and obligations under the transaction documents. This document cannot be reproduced except in full, without prior written approval of the Company. Any unauthorized alteration, forgery or falsification of the content or appearance of this document is unlawful and offenders may be prosecuted to the fullest extent of the law. Unless otherwise stated the results shown in this test report refer only to the sample(s) tested.

Attention: To check the authenticity of testing / inspection report & certificate, please contact us at telephone: (86-755) 8307 1443, or email: CN.Doccheck@sgs.com

Test Report

Report No. SCL01H013155001

Page 1 of 7

Applicant DONGGUAN SUNWAY PRINTING INDUSTRY CO.,LTD

Address YINLING INDUSTRIAL, XIAQIAO GUANLONG ROAD, DONGCHENG ZONE,
DONGGUAN CITY, GUANGDONG PROVINCE, CHINA

The following sample(s) and sample information was/were submitted and identified by/on the behalf of the client

Sample Name 上光PP膜
Part No. OPAT
Color 透明
Manufacturer FUZHOU
Sample Received Date Mar. 2, 2015
Testing Period Mar. 2, 2015 to Mar. 4, 2015

Test Requested As specified by client, to test Lead (Pb), Cadmium (Cd), Mercury (Hg), Hexavalent Chromium(Cr(VI)), Polybrominated Biphenyl(PBBs), Polybrominated Diphenyl Ethers(PBDEs), Fluorine(F), Chlorine(Cl), Bromine(Br), Iodine(I), Hexabromocyclododecane (HBCDD), Phthalates in the submitted sample(s).

Test Method Please refer to the following page(s).

Test Result(s) Please refer to the following page(s).

Tested by

Mett

Reviewed by

Cathy

Approved by

Danli

Date

Mar. 4, 2015

Danny Liu
Technical Manager

No. R148192600

Centre Testing International (Shenzhen) Co., Ltd. Hongwei Industrial Zone, Bao'an 70 District, Shenzhen, Guangdong, China

Test Report

Report No. SCL01H013155001

Page 2 of 7

Test Method

Test Item(s)	Test Method	Measured Equipment(s)
Lead (Pb)	IEC 62321-5:2013 Ed.1.0	ICP-OES
Cadmium (Cd)	IEC 62321-5:2013 Ed.1.0	ICP-OES
Mercury (Hg)	IEC 62321-4:2013 Ed.1.0	ICP-OES
Hexavalent Chromium(Cr(VI))	IEC 62321:2008 Ed.1 Annex C	UV-Vis
Polybrominated Biphenyl(PBBs)	IEC 62321:2008 Ed.1 Annex A	GC-MS
Polybrominated Diphenyl Ethers(PBDEs)	IEC 62321:2008 Ed.1 Annex A	GC-MS
Fluorine(F)	Refer to BS EN 14582:2007	IC
Chlorine(Cl)	Refer to BS EN 14582:2007	IC
Bromine(Br)	Refer to BS EN 14582:2007	IC
Iodine(I)	Refer to BS EN 14582:2007	IC
Hexabromocyclododecane (HBCDD)	Refer to US EPA 3540C:1996 & US EPA 8270D:2007	GC-MS
Phthalates	Refer to EN 14372:2004(E)	GC-MS

Test Result(s)

Tested Item(s)	Result	MDL
Lead (Pb)	N.D.	2 mg/kg
Cadmium (Cd)	N.D.	2 mg/kg
Mercury (Hg)	N.D.	2 mg/kg
Hexavalent Chromium (Cr(VI))	N.D.	2 mg/kg

Tested Item(s)	Result	MDL
Polybrominated Biphenyl(PBBs)		
Monobromobiphenyl	N.D.	5 mg/kg
Dibromobiphenyl	N.D.	5 mg/kg
Tribromobiphenyl	N.D.	5 mg/kg
Tetrabromobiphenyl	N.D.	5 mg/kg
Pentabromobiphenyl	N.D.	5 mg/kg
Hexabromobiphenyl	N.D.	5 mg/kg
Heptabromobiphenyl	N.D.	5 mg/kg
Octabromobiphenyl	N.D.	5 mg/kg
Nonabromobiphenyl	N.D.	5 mg/kg
Decabromobiphenyl	N.D.	5 mg/kg

Test Report

Report No. SCL01H013155001

Page 3 of 7

Tested Item(s)	Result	MDL
Polybrominated Diphenyl Ethers(PBDEs)		
Monobromodiphenyl ether	N.D.	5 mg/kg
Dibromodiphenyl ether	N.D.	5 mg/kg
Tribromodiphenyl ether	N.D.	5 mg/kg
Tetrabromodiphenyl ether	N.D.	5 mg/kg
Pentabromodiphenyl ether	N.D.	5 mg/kg
Hexabromodiphenyl ether	N.D.	5 mg/kg
Heptabromodiphenyl ether	N.D.	5 mg/kg
Octabromodiphenyl ether	N.D.	5 mg/kg
Nonabromodiphenyl ether	N.D.	5 mg/kg
Decabromodiphenyl ether	N.D.	5 mg/kg

Tested Item(s)	Result	MDL
Halogen(s)		
Fluorine(F)	N.D.	10 mg/kg
Chlorine(Cl)	N.D.	10 mg/kg
Bromine(Br)	N.D.	10 mg/kg
Iodine(I)	N.D.	10 mg/kg

Tested Item(s)	Result	MDL
Hexabromocyclododecane (HBCDD)	N.D.	5 mg/kg

Test Report

Report No. SCL01H013155001

Page 4 of 7

Tested Item(s)	Result	MDL
Phthalates		
Dimethyl phthalate(DMP) CAS#:131-11-3	N.D.	50 mg/kg
Diethyl phthalate(DEP) CAS#:84-66-2	N.D.	50 mg/kg
Diisobutyl phthalate(DIBP) CAS#:84-69-5	N.D.	50 mg/kg
Dibutyl phthalate(DBP) CAS#:84-74-2	N.D.	50 mg/kg
Butylbenzyl phthalate(BBP) CAS#:85-68-7	N.D.	50 mg/kg
Di-2-ethylhexyl phthalate(DEHP) CAS#:117-81-7	N.D.	50 mg/kg
Di-n-octyl phthalate(DNOP) CAS#:117-84-0	N.D.	50 mg/kg
Diisononyl phthalate(DINP) CAS#:28553-12-0,68515-48-0	N.D.	50 mg/kg
Diisodecyl phthalate(DIDP) CAS#:26761-40-0,68515-49-1	N.D.	50 mg/kg
Di-n-hexyl phthalate (DNHP) CAS#:84-75-3	N.D.	50 mg/kg

Tested Sample/Part Description

Transparent plastic film with adhesive paste

Remark: The sample(s) had been dissolved totally tested for Lead, Cadmium, Mercury.

-MDL = Method Detection Limit

 -N.D. = Not Detected (\leq MDL)

-mg/kg = ppm = parts per million

Test Report

Report No. SCL01H013155001

Page 5 of 7

Test Process

1. Lead (Pb), Cadmium (Cd)

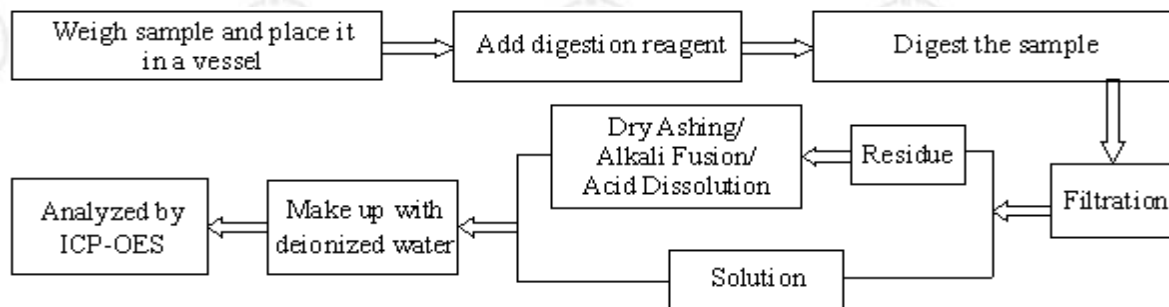

2. Mercury (Hg)

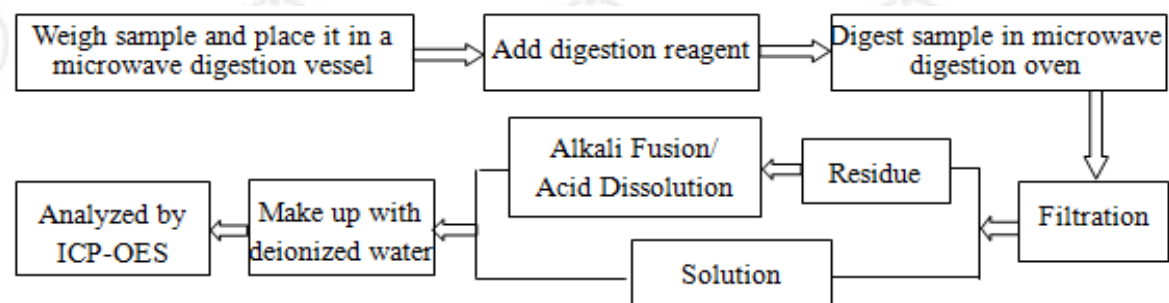

3. Hexavalent Chromium(Cr(VI))

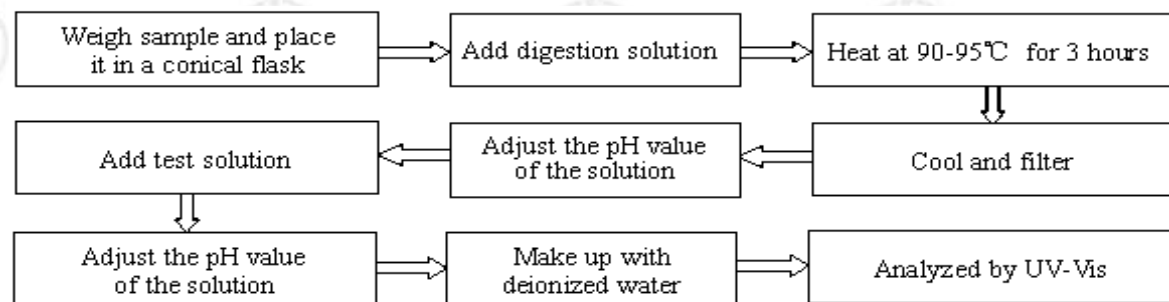

4. Phthalates

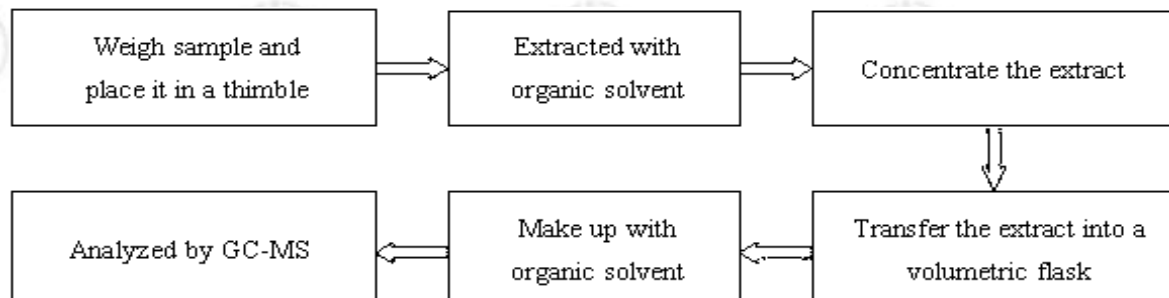

Test Report

Report No. SCL01H013155001

Page 6 of 7

5. Bromine(Br), Chlorine(Cl), Fluorine(F), Iodine(I)

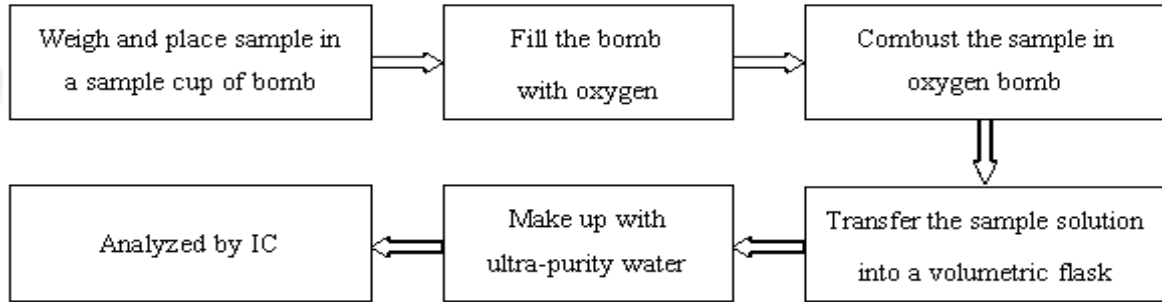

6. Polybrominated Biphenyl(PBBs) , Polybrominated Diphenyl Ethers(PBDEs)

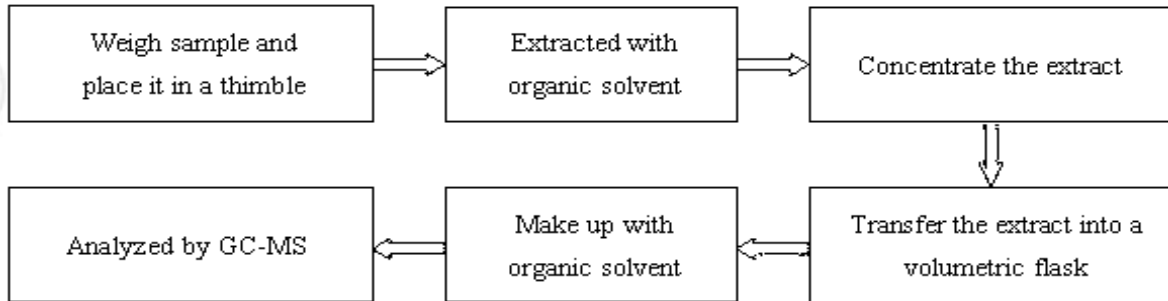

7. Hexabromocyclododecane (HBCDD)

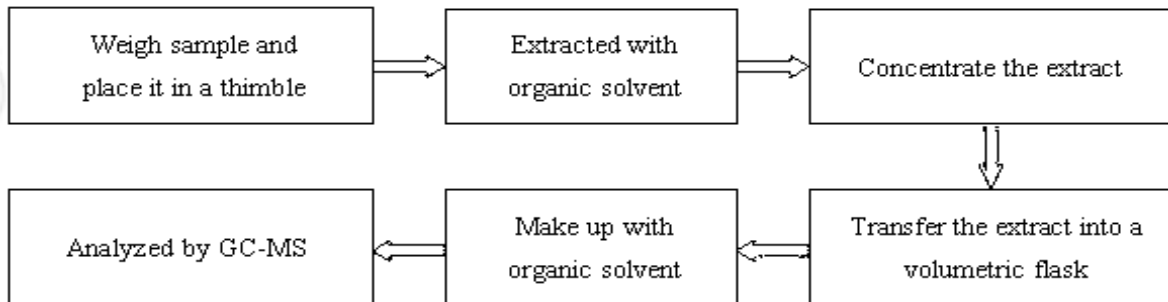

Test Report

Report No. SCL01H013155001

Page 7 of 7

Photo(s) of the sample(s)

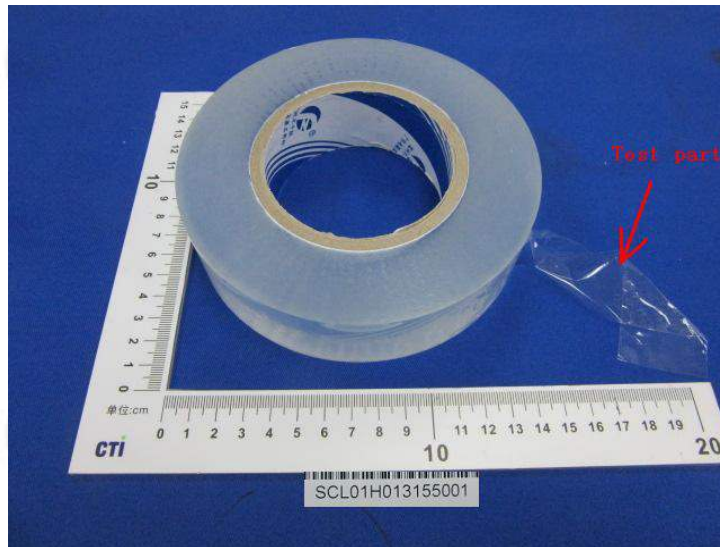

*** End of report ***

The test report is effective only with both signature and specialized stamp. The result(s) shown in this report refer only to the sample(s) tested. Without written approval of CTI, this report can't be reproduced except in full.

Test Report

No. CANEC1417706703

Date: 04 Nov 2014

Page 1 of 10

FOUR PILLARS INDUSTRIAL(SHENZHEN)CO.,LTD.

FOUR PILLARS TECHNOLOGIES & APPLIED MATERIALS(SHENZHEN)CO.,LTD.

FIRST AND SECOND BUILDING,THIRD INDUSTRIAL ZONE,FENGHUANG COUNTRY,FUYONG TOWN,BAOAN DISTRICT,SHENZHEN ,CHINA

The following sample(s) was/were submitted and identified on behalf of the clients as : Label

SGS Job No. : CP14-056931 - SZ

Model No. : PO32AZ

Lot No. : 49361105

Client Ref. Info. : PO32AZ, PO3BZ, PO3MAZ, PO3MZ, PO6BZ, PO6GZ, PO6LZ, PO6MZ, PO6NZ, PO6TZ, PO6WZ, PO72AZ, PO72BZ, PO72TZ, PO72Z, PO7MCZ, PO7YZ, PO7NZ, PO92Z, PO94AZ, PO9BHZ, PO9LZ, PO9MGZ, PO9MHZ, PO9MZ, PO9WZ, POBDZ, POBEZ, POBGZ,POBHZ,POBKZ,PO3BWZ , PO5MZ, PO9BZ

Manufacturer : FOUR PILLARS INDUSTRIAL(SHENZHEN)CO.,LTD.
FOUR PILLARS TECHNOLOGIES & APPLIED MATERIALS(SHENZHEN)CO.,LTD.

Manufacturer Address : FIRST AND SECOND BUILDING,THIRD INDUSTRIAL ZONE,FENGHUANG COUNTRY,FUYONG TOWN,BAOAN DISTRICT,SHENZHEN ,CHINA

Date of Sample Received : 29 Oct 2014

Testing Period : 29 Oct 2014 - 04 Nov 2014

Test Requested : Selected test(s) as requested by client.

Test Method : Please refer to next page(s).

Test Results : Please refer to next page(s).

Conclusion : Based on the performed tests on submitted sample(s), the results of Lead, Mercury, Cadmium, Hexavalent chromium, Polybrominated biphenyls (PBBs), Polybrominated diphenyl ethers (PBDEs) comply with the limits as set by RoHS Directive 2011/65/EU Annex II; recasting 2002/95/EC.



This document is issued by the Company subject to its General Conditions of Service printed overleaf, available on request or accessible at <http://www.sgs.com/en/Terms-and-Conditions.aspx> and, for electronic format documents, subject to Terms and Conditions for Electronic Documents at <http://www.sgs.com/en/Terms-and-Conditions/Terms-e-Documents.aspx>. Attention is drawn to the limitation of liability, indemnification and jurisdiction issues defined therein. Any holder of this document is advised that information contained hereon reflects the Company's findings at the time of its intervention only and within the limits of Client's instructions, if any. The Company's sole responsibility is to its Client and this document does not exonerate parties to a transaction from exercising all their rights and obligations under the transaction documents. This document cannot be reproduced except in full, without prior written approval of the Company. Any unauthorized alteration, forgery or falsification of the content or appearance of this document is unlawful and offenders may be prosecuted to the fullest extent of the law. Unless otherwise stated the results shown in this test report refer only to the sample(s) tested.
Attention: To check the authenticity of testing /inspection report & certificate, please contact us at telephone: (86-755) 8307 1443, or email: CN.Doccheck@sgs.com

SGS-CTI Standards Technical Services Co., Ltd.
Guangzhou Chemical Laboratory

198 Kezhu Road, Sciencetech Park Guangzhou Economic & Technology Development District, Guangzhou, China 510663 t (86-20) 82155555 f (86-20) 82075113 www.sgsgroup.com.cn
中国·广州·经济技术开发区科学城科珠路198号 邮编: 510663 t (86-20) 82155555 f (86-20) 82075113 e sgs.china@sgs.com

Test Report

No. CANEC1417706703

Date: 04 Nov 2014

Page 2 of 10

Signed for and on behalf of
SGS-CSTC Ltd.

Merry Lv
Approved Signatory



This document is issued by the Company subject to its General Conditions of Service printed overleaf, available on request or accessible at <http://www.sgs.com/en/Terms-and-Conditions.aspx> and, for electronic format documents, subject to Terms and Conditions for Electronic Documents at <http://www.sgs.com/en/Terms-and-Conditions/Terms-e-Documents.aspx>. Attention is drawn to the limitation of liability, indemnification and jurisdiction issues defined therein. Any holder of this document is advised that information contained hereon reflects the Company's findings at the time of its intervention only and within the limits of Client's instructions, if any. The Company's sole responsibility is to its Client and this document does not exonerate parties to a transaction from exercising all their rights and obligations under the transaction documents. This document cannot be reproduced except in full, without prior written approval of the Company. Any unauthorized alteration, forgery or falsification of the content or appearance of this document is unlawful and offenders may be prosecuted to the fullest extent of the law. Unless otherwise stated the results shown in this test report refer only to the sample(s) tested.

Attention: To check the authenticity of testing / inspection report & certificate, please contact us at telephone: (86-755) 8307 1443, or email: CN.Doccheck@sgs.com

Test Results :

Test Part Description :

Specimen No.	SGS Sample ID	Description
SN1	CAN14-177067.003	Silvery adhesive sheet

Remarks :

- (1) 1 mg/kg = 1 ppm = 0.0001%
- (2) MDL = Method Detection Limit
- (3) ND = Not Detected (< MDL)
- (4) "-" = Not Regulated

RoHS Directive 2011/65/EU

- Test Method :
- (1)With reference to IEC 62321-5:2013, determination of Cadmium by ICP-OES.
 - (2)With reference to IEC 62321-5:2013, determination of Lead by ICP-OES.
 - (3)With reference to IEC 62321-4:2013, determination of Mercury by ICP-OES.
 - (4)With reference to IEC 62321:2008, determination of Hexavalent Chromium by Colorimetric Method using UV-Vis.
 - (5)With reference to IEC 62321:2008, determination of PBBs and PBDEs by GC-MS.

<u>Test Item(s)</u>	<u>Limit</u>	<u>Unit</u>	<u>MDL</u>	<u>003</u>
Cadmium (Cd)	100	mg/kg	2	ND
Lead (Pb)	1,000	mg/kg	2	ND
Mercury (Hg)	1,000	mg/kg	2	ND
Hexavalent Chromium (CrVI)	1,000	mg/kg	2	ND
Sum of PBBs	1,000	mg/kg	-	ND
Monobromobiphenyl	-	mg/kg	5	ND
Dibromobiphenyl	-	mg/kg	5	ND
Tribromobiphenyl	-	mg/kg	5	ND
Tetrabromobiphenyl	-	mg/kg	5	ND
Pentabromobiphenyl	-	mg/kg	5	ND
Hexabromobiphenyl	-	mg/kg	5	ND
Heptabromobiphenyl	-	mg/kg	5	ND
Octabromobiphenyl	-	mg/kg	5	ND
Nonabromobiphenyl	-	mg/kg	5	ND
Decabromobiphenyl	-	mg/kg	5	ND
Sum of PBDEs	1,000	mg/kg	-	ND
Monobromodiphenyl ether	-	mg/kg	5	ND



This document is issued by the Company subject to its General Conditions of Service printed overleaf, available on request or accessible at <http://www.sgs.com/en/Terms-and-Conditions.aspx> and, for electronic format documents, subject to Terms and Conditions for Electronic Documents at <http://www.sgs.com/en/Terms-and-Conditions/Terms-e-Documents.aspx>. Attention is drawn to the limitation of liability, indemnification and jurisdiction issues defined therein. Any holder of this document is advised that information contained hereon reflects the Company's findings at the time of its intervention only and within the limits of Client's instructions, if any. The Company's sole responsibility is to its Client and this document does not exonerate parties to a transaction from exercising all their rights and obligations under the transaction documents. This document cannot be reproduced except in full, without prior written approval of the Company. Any unauthorized alteration, forgery or falsification of the content or appearance of this document is unlawful and offenders may be prosecuted to the fullest extent of the law. Unless otherwise stated the results shown in this test report refer only to the sample(s) tested.

Attention: To check the authenticity of testing /inspection report & certificate, please contact us at telephone: (86-755) 8307 1443, or email: CN.Doccheck@sgs.com

198 Kezhu Road, Sciencetech Park Guangzhou Economic & Technology Development District, Guangzhou, China 510663 t (86-20) 82155555 f (86-20) 82075113 www.sgsgroup.com.cn
中国·广州·经济技术开发区科学城科珠路198号 邮编: 510663 t (86-20) 82155555 f (86-20) 82075113 e sgs.china@sgs.com

Test Report

No. CANEC1417706703

Date: 04 Nov 2014

Page 4 of 10

<u>Test Item(s)</u>	<u>Limit</u>	<u>Unit</u>	<u>MDL</u>	<u>003</u>
Dibromodiphenyl ether	-	mg/kg	5	ND
Tribromodiphenyl ether	-	mg/kg	5	ND
Tetrabromodiphenyl ether	-	mg/kg	5	ND
Pentabromodiphenyl ether	-	mg/kg	5	ND
Hexabromodiphenyl ether	-	mg/kg	5	ND
Heptabromodiphenyl ether	-	mg/kg	5	ND
Octabromodiphenyl ether	-	mg/kg	5	ND
Nonabromodiphenyl ether	-	mg/kg	5	ND
Decabromodiphenyl ether	-	mg/kg	5	ND

Notes :

- (1) The maximum permissible limit is quoted from the directive 2011/65/EU, Annex II.

Halogen

Test Method : With reference to EN 14582: 2007, analysis was performed by Ion Chromatograph (IC).

<u>Test Item(s)</u>	<u>Unit</u>	<u>MDL</u>	<u>003</u>
Fluorine (F)	mg/kg	50	ND
Chlorine (Cl)	mg/kg	50	ND
Bromine (Br)	mg/kg	50	ND
Iodine (I)	mg/kg	50	ND

Hexabromocyclododecane (HBCDD)

Test Method : Determination of HBCDD by GC-MS based on IEC 62321:2008.

<u>Test Item(s)</u>	<u>Unit</u>	<u>MDL</u>	<u>003</u>
Hexabromocyclododecane (HBCDD)	mg/kg	10	ND

Notes :

- (1) Reference Information: Directive 2011/65/EU recasting RoHS directive 2002/95/EC: Hexabromocyclododecane (HBCDD) is considered as a priority for risk evaluation and substance restriction.

Phthalate

Test Method : Determination of phthalates by GC-MS based on EN 14372:2004.



This document is issued by the Company subject to its General Conditions of Service printed overleaf, available on request or accessible at <http://www.sgs.com/en/Terms-and-Conditions.aspx> and, for electronic format documents, subject to Terms and Conditions for Electronic Documents at <http://www.sgs.com/en/Terms-and-Conditions/Terms-e-Documents.aspx>. Attention is drawn to the limitation of liability, indemnification and jurisdiction issues defined therein. Any holder of this document is advised that information contained hereon reflects the Company's findings at the time of its intervention only and within the limits of Client's instructions, if any. The Company's sole responsibility is to its Client and this document does not exonerate parties to a transaction from exercising all their rights and obligations under the transaction documents. This document cannot be reproduced except in full, without prior written approval of the Company. Any unauthorized alteration, forgery or falsification of the content or appearance of this document is unlawful and offenders may be prosecuted to the fullest extent of the law. Unless otherwise stated the results shown in this test report refer only to the sample(s) tested.

Attention: To check the authenticity of testing /inspection report & certificate, please contact us at telephone: (86-755) 8307 1443, or email: CN.Doccheck@sgs.com

Test Report

No. CANEC1417706703

Date: 04 Nov 2014

Page 5 of 10

<u>Test Item(s)</u>	<u>CAS NO.</u>	<u>Unit</u>	<u>MDL</u>	<u>003</u>
Dibutyl Phthalate (DBP)	84-74-2	%(w/w)	0.003	ND
Benzylbutyl Phthalate (BBP)	85-68-7	%(w/w)	0.003	ND
Bis(2-ethylhexyl) Phthalate (DEHP)	117-81-7	%(w/w)	0.003	ND

Notes :

- (1) Reference Information: Directive 2011/65/EU recasting RoHS directive 2002/95/EC:
Bis (2-ethylhexyl) phthalate (DEHP), Butyl benzyl phthalate (BBP) and Dibutyl phthalate (DBP) are considered as a priority for risk evaluation and substance restriction.



This document is issued by the Company subject to its General Conditions of Service printed overleaf, available on request or accessible at <http://www.sgs.com/en/Terms-and-Conditions.aspx> and, for electronic format documents, subject to Terms and Conditions for Electronic Documents at <http://www.sgs.com/en/Terms-and-Conditions/Terms-e-Documents.aspx>. Attention is drawn to the limitation of liability, indemnification and jurisdiction issues defined therein. Any holder of this document is advised that information contained hereon reflects the Company's findings at the time of its intervention only and within the limits of Client's instructions, if any. The Company's sole responsibility is to its Client and this document does not exonerate parties to a transaction from exercising all their rights and obligations under the transaction documents. This document cannot be reproduced except in full, without prior written approval of the Company. Any unauthorized alteration, forgery or falsification of the content or appearance of this document is unlawful and offenders may be prosecuted to the fullest extent of the law. Unless otherwise stated the results shown in this test report refer only to the sample(s) tested.

Attention: To check the authenticity of testing / inspection report & certificate, please contact us at telephone: (86-755) 8307 1443, or email: CN.Doccheck@sgs.com

SGS-CTI Standards Technical Services Co., Ltd.
Guangzhou Chemical Laboratory

198 Kezhu Road, Sciencetech Park Guangzhou Economic & Technology Development District, Guangzhou, China 510663 t (86-20) 82155555 f (86-20) 82075113 www.sgsgroup.com.cn
中国·广州·经济技术开发区科学城科珠路198号 邮编: 510663 t (86-20) 82155555 f (86-20) 82075113 e sgs.china@sgs.com

ATTACHMENTS

RoHS Testing Flow Chart

- 1) Name of the person who made testing: Bruce Xiao / Sunny Hu
- 2) Name of the person in charge of testing: Bella Wang / Cutey Yu
- 3) These samples were dissolved totally by pre-conditioning method according to below flow chart (Cr⁶⁺ and PBBs/PBDEs test method excluded).

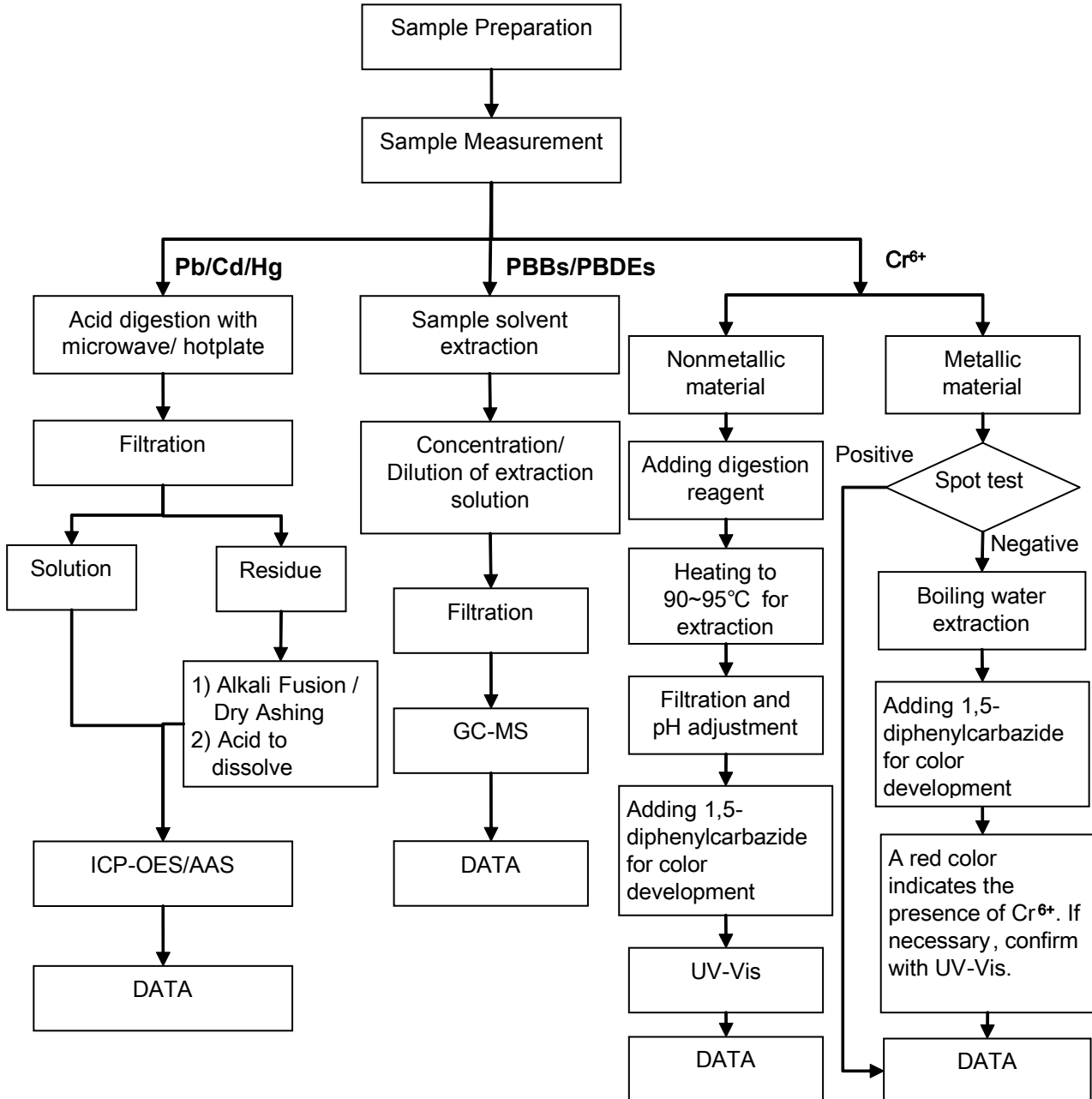

This document is issued by the Company subject to its General Conditions of Service printed overleaf, available on request or accessible at <http://www.sgs.com/en/Terms-and-Conditions.aspx> and, for electronic format documents, subject to Terms and Conditions for Electronic Documents at <http://www.sgs.com/en/Terms-and-Conditions/Terms-e-Documents.aspx>. Attention is drawn to the limitation of liability, indemnification and jurisdiction issues defined therein. Any holder of this document is advised that information contained herein reflects the Company's findings at the time of its intervention only and within the limits of Client's instructions, if any. The Company's sole responsibility is to its Client and this document does not exonerate parties to a transaction from exercising all their rights and obligations under the transaction documents. This document cannot be reproduced except in full, without prior written approval of the Company. Any unauthorized alteration, forgery or falsification of the content or appearance of this document is unlawful and offenders may be prosecuted to the fullest extent of the law. Unless otherwise stated the results shown in this test report refer only to the sample(s) tested.

Attention: To check the authenticity of testing / inspection report & certificate, please contact us at telephone: (86-755) 8307 1443, or email: CN.Doccheck@sgs.com

198 Kezhu Road, Sciencetech Park Guangzhou Economic & Technology Development District, Guangzhou, China 510663 t (86-20) 82155555 f (86-20) 82075113 www.sgsgroup.com.cn
中国·广州·经济技术开发区科学城科珠路198号 邮编: 510663 t (86-20) 82155555 f (86-20) 82075113 e sgs.china@sgs.com

ATTACHMENTS

HBCDD Testing Flow Chart

- 1) Name of the person who made testing: Sunny Hu
- 2) Name of the person in charge of testing: Cutey Yu

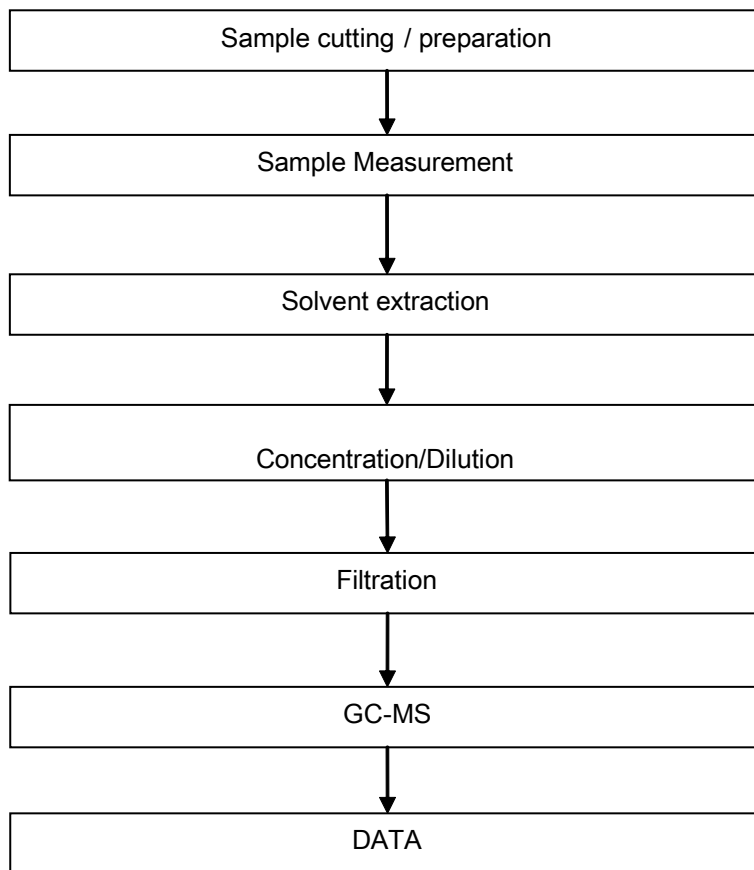

This document is issued by the Company subject to its General Conditions of Service printed overleaf, available on request or accessible at <http://www.sgs.com/en/Terms-and-Conditions.aspx> and, for electronic format documents, subject to Terms and Conditions for Electronic Documents at <http://www.sgs.com/en/Terms-and-Conditions/Terms-e-Documents.aspx>. Attention is drawn to the limitation of liability, indemnification and jurisdiction issues defined therein. Any holder of this document is advised that information contained hereon reflects the Company's findings at the time of its intervention only and within the limits of Client's instructions, if any. The Company's sole responsibility is to its Client and this document does not exonerate parties to a transaction from exercising all their rights and obligations under the transaction documents. This document cannot be reproduced except in full, without prior written approval of the Company. Any unauthorized alteration, forgery or falsification of the content or appearance of this document is unlawful and offenders may be prosecuted to the fullest extent of the law. Unless otherwise stated the results shown in this test report refer only to the sample(s) tested.

Attention: To check the authenticity of testing / inspection report & certificate, please contact us at telephone: (86-755) 8307 1443, or email: CN.Doccheck@sgs.com

198 Kezhu Road, Sciencetech Park Guangzhou Economic & Technology Development District, Guangzhou, China 510663 t (86-20) 82155555 f (86-20) 82075113 www.sgsgroup.com.cn
 中国·广州·经济技术开发区科学城科珠路198号 邮编: 510663 t (86-20) 82155555 f (86-20) 82075113 e sgs.china@sgs.com

ATTACHMENTS

Phthalates Testing Flow Chart

- 1) Name of the person who made testing: Sunny Hu
- 2) Name of the person in charge of testing: Cutey Yu

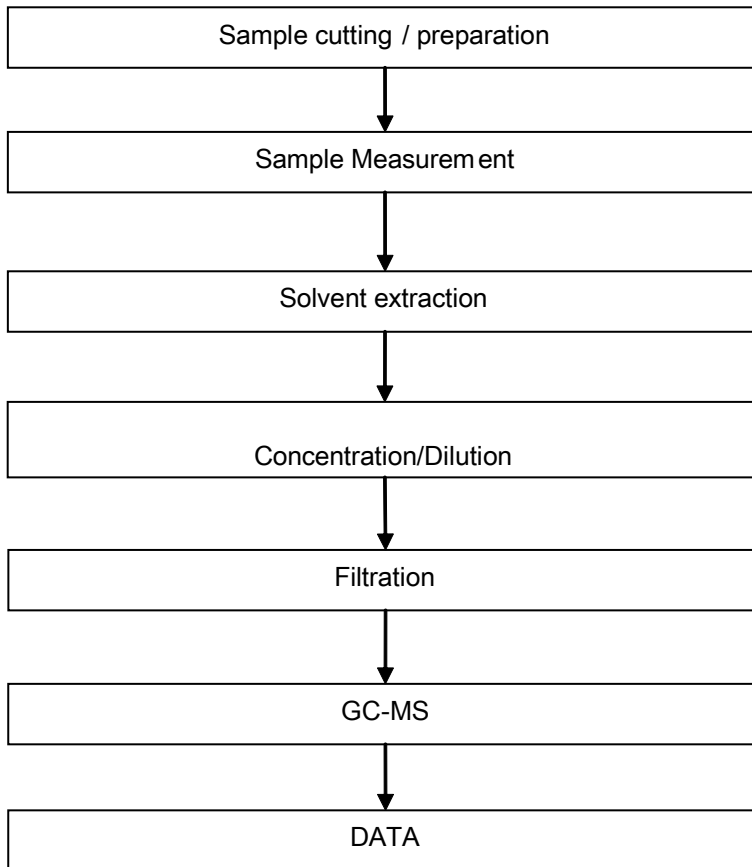

This document is issued by the Company subject to its General Conditions of Service printed overleaf, available on request or accessible at <http://www.sgs.com/en/Terms-and-Conditions.aspx> and, for electronic format documents, subject to Terms and Conditions for Electronic Documents at <http://www.sgs.com/en/Terms-and-Conditions/Terms-e-Documents.aspx>. Attention is drawn to the limitation of liability, indemnification and jurisdiction issues defined therein. Any holder of this document is advised that information contained hereon reflects the Company's findings at the time of its intervention only and within the limits of Client's instructions, if any. The Company's sole responsibility is to its Client and this document does not exonerate parties to a transaction from exercising all their rights and obligations under the transaction documents. This document cannot be reproduced except in full, without prior written approval of the Company. Any unauthorized alteration, forgery or falsification of the content or appearance of this document is unlawful and offenders may be prosecuted to the fullest extent of the law. Unless otherwise stated the results shown in this test report refer only to the sample(s) tested.

Attention: To check the authenticity of testing / inspection report & certificate, please contact us at telephone: (86-755) 8307 1443, or email: CN.Doccheck@sgs.com

198 Kezhu Road, Sciencetech Park Guangzhou Economic & Technology Development District, Guangzhou, China 510663 t (86-20) 82155555 f (86-20) 82075113 www.sgsgroup.com.cn
 中国·广州·经济技术开发区科学城科珠路198号 邮编: 510663 t (86-20) 82155555 f (86-20) 82075113 e sgs.china@sgs.com

ATTACHMENTS

Halogen Testing Flow Chart

- 1) Name of the person who made testing: Hanming Xiao
- 2) Name of the person in charge of testing: Bella Wang

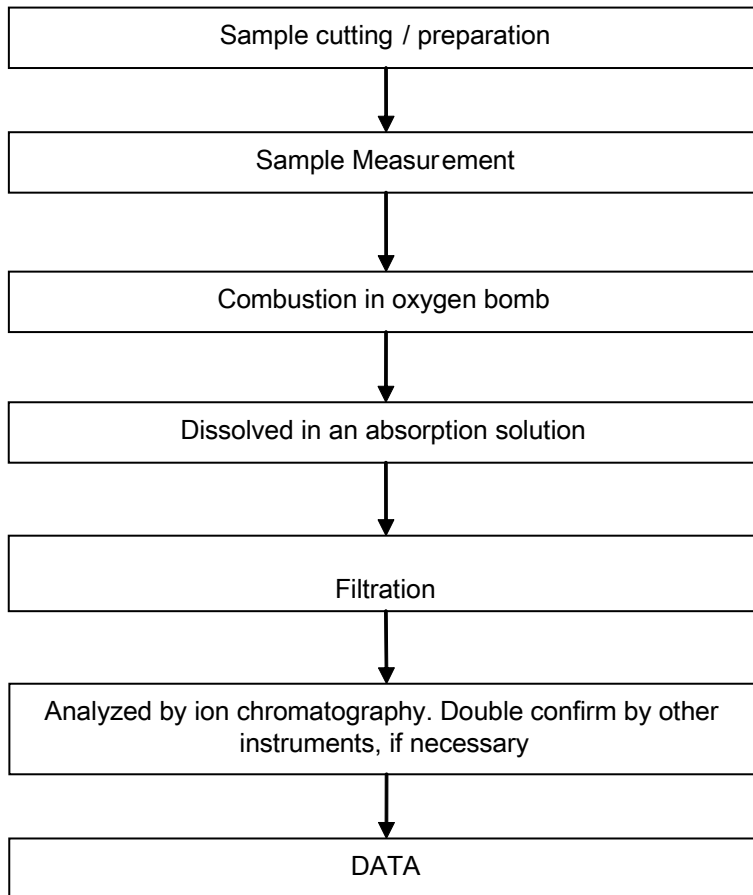

This document is issued by the Company subject to its General Conditions of Service printed overleaf, available on request or accessible at <http://www.sgs.com/en/Terms-and-Conditions.aspx> and, for electronic format documents, subject to Terms and Conditions for Electronic Documents at <http://www.sgs.com/en/Terms-and-Conditions/Terms-e-Documents.aspx>. Attention is drawn to the limitation of liability, indemnification and jurisdiction issues defined therein. Any holder of this document is advised that information contained hereon reflects the Company's findings at the time of its intervention only and within the limits of Client's instructions, if any. The Company's sole responsibility is to its Client and this document does not exonerate parties to a transaction from exercising all their rights and obligations under the transaction documents. This document cannot be reproduced except in full, without prior written approval of the Company. Any unauthorized alteration, forgery or falsification of the content or appearance of this document is unlawful and offenders may be prosecuted to the fullest extent of the law. Unless otherwise stated the results shown in this test report refer only to the sample(s) tested.

Attention: To check the authenticity of testing / inspection report & certificate, please contact us at telephone: (86-755) 8307 1443, or email: CN.Doccheck@sgs.com

Sample photo:

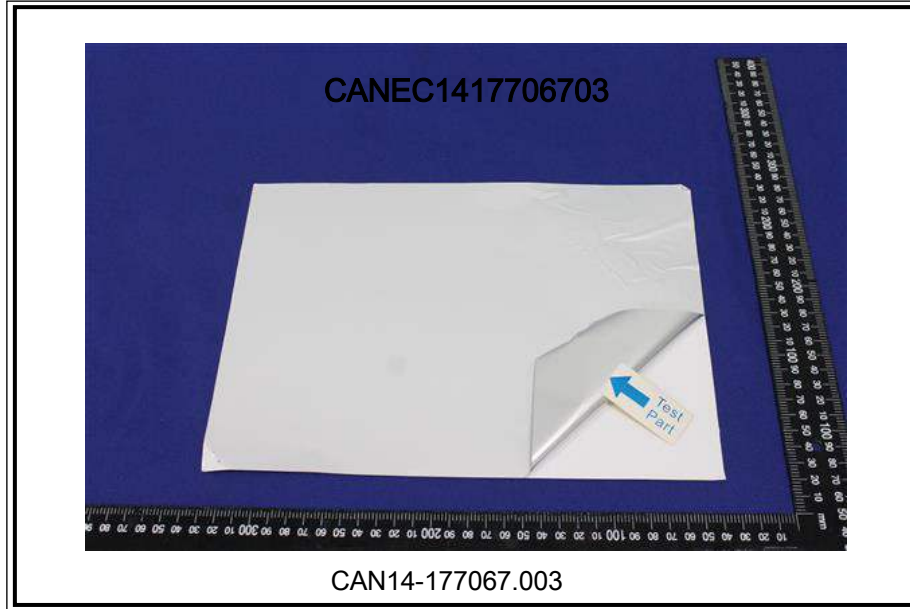

SGS authenticate the photo on original report only

*** End of Report ***

Test Report

No. CANEC1421385503

Date: 29 Dec 2014

Page 1 of 8

XIAMEN JISSYU SOLDER CO.,LTD.

5F,NO.9-19,FANGHU ROAD,HULI DISTRICT,XIAMEN
CHINA

The following sample(s) was/were submitted and identified on behalf of the clients as : DFC Solder Paste

SGS Job No. : CP14-067653 - GZ

Date of Sample Received : 23 Dec 2014

Testing Period : 23 Dec 2014 - 29 Dec 2014

Test Requested : Selected test(s) as requested by client.

Test Method : Please refer to next page(s).

Test Results : Please refer to next page(s).

Conclusion : Based on the performed tests on submitted sample(s), the results of Lead, Mercury, Cadmium, Hexavalent chromium, Polybrominated biphenyls (PBBs), Polybrominated diphenyl ethers (PBDEs) comply with the limits as set by RoHS Directive 2011/65/EU Annex II; recasting 2002/95/EC.

Signed for and on behalf of
SGS-CSTC Ltd.



Merry Lv
Approved Signatory



This document is issued by the Company subject to its General Conditions of Service printed overleaf, available on request or accessible at <http://www.sgs.com/en/Terms-and-Conditions.aspx> and, for electronic format documents, subject to Terms and Conditions for Electronic Documents at <http://www.sgs.com/en/Terms-and-Conditions/Terms-e-Document.aspx>. Attention is drawn to the limitation of liability, indemnification and jurisdiction issues defined therein. Any holder of this document is advised that information contained hereon reflects the Company's findings at the time of its intervention only and within the limits of Client's instructions, if any. The Company's sole responsibility is to its Client and this document does not exonerate parties to a transaction from exercising all their rights and obligations under the transaction documents. This document cannot be reproduced except in full, without prior written approval of the Company. Any unauthorized alteration, forgery or falsification of the content or appearance of this document is unlawful and offenders may be prosecuted to the fullest extent of the law. Unless otherwise stated the results shown in this test report refer only to the sample(s) tested.

Attention: To check the authenticity of testing /inspection report & certificate, please contact us at telephone: (86-755) 8307 1443, or email: CN.Doccheck@sgs.com

198 Kezhu Road, Sciencetech Park Guangzhou Economic & Technology Development District, Guangzhou, China 510663 t (86-20) 82155555 f (86-20) 82075113 www.sgsgroup.com.cn
中国·广州·经济技术开发区科学城科珠路198号 邮编: 510663 t (86-20) 82155555 f (86-20) 82075113 e sgs.china@sgs.com

Test Report

No. CANEC1421385503

Date: 29 Dec 2014

Page 2 of 8

Test Results :

Test Part Description :

Specimen No.	SGS Sample ID	Description
SN1	CAN14-213855.002	Gray paste

Remarks :

- (1) 1 mg/kg = 0.0001%
- (2) MDL = Method Detection Limit
- (3) ND = Not Detected (< MDL)
- (4) "-" = Not Regulated

RoHS Directive 2011/65/EU

- Test Method :
- (1)With reference to IEC 62321-5:2013, determination of Cadmium by ICP-OES.
 - (2)With reference to IEC 62321-5:2013, determination of Lead by ICP-OES.
 - (3)With reference to IEC 62321-4:2013, determination of Mercury by ICP-OES.
 - (4)With reference to IEC 62321:2008, determination of Hexavalent Chromium by Colorimetric Method using UV-Vis.
 - (5)With reference to IEC 62321:2008, determination of PBBs and PBDEs by GC-MS.

<u>Test Item(s)</u>	<u>Limit</u>	<u>Unit</u>	<u>MDL</u>	<u>002</u>
Cadmium (Cd)	100	mg/kg	2	ND
Lead (Pb)	1,000	mg/kg	2	11
Mercury (Hg)	1,000	mg/kg	2	ND
Hexavalent Chromium (CrVI)	1,000	mg/kg	2	ND
Sum of PBBs	1,000	mg/kg	-	ND
Monobromobiphenyl	-	mg/kg	5	ND
Dibromobiphenyl	-	mg/kg	5	ND
Tribromobiphenyl	-	mg/kg	5	ND
Tetrabromobiphenyl	-	mg/kg	5	ND
Pentabromobiphenyl	-	mg/kg	5	ND
Hexabromobiphenyl	-	mg/kg	5	ND
Heptabromobiphenyl	-	mg/kg	5	ND
Octabromobiphenyl	-	mg/kg	5	ND
Nonabromobiphenyl	-	mg/kg	5	ND
Decabromobiphenyl	-	mg/kg	5	ND
Sum of PBDEs	1,000	mg/kg	-	ND
Monobromodiphenyl ether	-	mg/kg	5	ND



This document is issued by the Company subject to its General Conditions of Service printed overleaf, available on request or accessible at <http://www.sgs.com/en/Terms-and-Conditions.aspx> and, for electronic format documents, subject to Terms and Conditions for Electronic Documents at <http://www.sgs.com/en/Terms-and-Conditions/Terms-e-Documents.aspx>. Attention is drawn to the limitation of liability, indemnification and jurisdiction issues defined therein. Any holder of this document is advised that information contained hereon reflects the Company's findings at the time of its intervention only and within the limits of Client's instructions, if any. The Company's sole responsibility is to its Client and this document does not exonerate parties to a transaction from exercising all their rights and obligations under the transaction documents. This document cannot be reproduced except in full, without prior written approval of the Company. Any unauthorized alteration, forgery or falsification of the content or appearance of this document is unlawful and offenders may be prosecuted to the fullest extent of the law. Unless otherwise stated the results shown in this test report refer only to the sample(s) tested.

Attention: To check the authenticity of testing /inspection report & certificate, please contact us at telephone: (86-755) 8307 1443, or email: CN.Doccheck@sgs.com

198 Kezhu Road, Sciencetech Park Guangzhou Economic & Technology Development District, Guangzhou, China 510663 t (86-20) 82155555 f (86-20) 82075113 www.sgsgroup.com.cn
中国·广州·经济技术开发区科学城科珠路198号 邮编: 510663 t (86-20) 82155555 f (86-20) 82075113 e sgs.china@sgs.com

Test Report

No. CANEC1421385503

Date: 29 Dec 2014

Page 3 of 8

<u>Test Item(s)</u>	<u>Limit</u>	<u>Unit</u>	<u>MDL</u>	<u>002</u>
Dibromodiphenyl ether	-	mg/kg	5	ND
Tribromodiphenyl ether	-	mg/kg	5	ND
Tetrabromodiphenyl ether	-	mg/kg	5	ND
Pentabromodiphenyl ether	-	mg/kg	5	ND
Hexabromodiphenyl ether	-	mg/kg	5	ND
Heptabromodiphenyl ether	-	mg/kg	5	ND
Octabromodiphenyl ether	-	mg/kg	5	ND
Nonabromodiphenyl ether	-	mg/kg	5	ND
Decabromodiphenyl ether	-	mg/kg	5	ND

Notes :

- (1) The maximum permissible limit is quoted from the directive 2011/65/EU, Annex II.

Hexabromocyclododecane (HBCDD)

Test Method : Determination of HBCDD by GC-MS based on IEC 62321:2008.

<u>Test Item(s)</u>	<u>Unit</u>	<u>MDL</u>	<u>002</u>
Hexabromocyclododecane (HBCDD)	mg/kg	10	ND

Notes :

- (1) Reference Information: Directive 2011/65/EU recasting RoHS directive 2002/95/EC:
Hexabromocyclododecane (HBCDD) is considered as a priority for risk evaluation and substance restriction.

Phthalate

Test Method : Determination of phthalates by GC-MS based on EN 14372:2004.

<u>Test Item(s)</u>	<u>CAS NO.</u>	<u>Unit</u>	<u>MDL</u>	<u>002</u>
Dibutyl Phthalate (DBP)	84-74-2	%(w/w)	0.003	ND
Benzylbutyl Phthalate (BBP)	85-68-7	%(w/w)	0.003	ND
Bis(2-ethylhexyl) Phthalate (DEHP)	117-81-7	%(w/w)	0.003	ND



This document is issued by the Company subject to its General Conditions of Service printed overleaf, available on request or accessible at <http://www.sgs.com/en/Terms-and-Conditions.aspx> and, for electronic format documents, subject to Terms and Conditions for Electronic Documents at <http://www.sgs.com/en/Terms-and-Conditions/Terms-e-Documents.aspx>. Attention is drawn to the limitation of liability, indemnification and jurisdiction issues defined therein. Any holder of this document is advised that information contained hereon reflects the Company's findings at the time of its intervention only and within the limits of Client's instructions, if any. The Company's sole responsibility is to its Client and this document does not exonerate parties to a transaction from exercising all their rights and obligations under the transaction documents. This document cannot be reproduced except in full, without prior written approval of the Company. Any unauthorized alteration, forgery or falsification of the content or appearance of this document is unlawful and offenders may be prosecuted to the fullest extent of the law. Unless otherwise stated the results shown in this test report refer only to the sample(s) tested.

Attention: To check the authenticity of testing / inspection report & certificate, please contact us at telephone: (86-755) 8307 1443, or email: CN.Doccheck@sgs.com

Test Report

No. CANEC1421385503

Date: 29 Dec 2014

Page 4 of 8

<u>Test Item(s)</u>	<u>CAS NO.</u>	<u>Unit</u>	<u>MDL</u>	<u>002</u>
Diisobutyl Phthalate (DIBP)	84-69-5	%(w/w)	0.003	ND

Notes :

- (1) Reference Information: Directive 2011/65/EU recasting RoHS directive 2002/95/EC: Bis (2-ethylhexyl) phthalate (DEHP), Butyl benzyl phthalate (BBP) and Dibutyl phthalate (DBP) are considered as a priority for risk evaluation and substance restriction.

Remark: The result(s) shown is/are of the total weight of wet sample.



This document is issued by the Company subject to its General Conditions of Service printed overleaf, available on request or accessible at <http://www.sgs.com/en/Terms-and-Conditions.aspx> and, for electronic format documents, subject to Terms and Conditions for Electronic Documents at <http://www.sgs.com/en/Terms-and-Conditions/Terms-e-Documents.aspx>. Attention is drawn to the limitation of liability, indemnification and jurisdiction issues defined therein. Any holder of this document is advised that information contained hereon reflects the Company's findings at the time of its intervention only and within the limits of Client's instructions, if any. The Company's sole responsibility is to its Client and this document does not exonerate parties to a transaction from exercising all their rights and obligations under the transaction documents. This document cannot be reproduced except in full, without prior written approval of the Company. Any unauthorized alteration, forgery or falsification of the content or appearance of this document is unlawful and offenders may be prosecuted to the fullest extent of the law. Unless otherwise stated the results shown in this test report refer only to the sample(s) tested.

Attention: To check the authenticity of testing /inspection report & certificate, please contact us at telephone: (86-755) 8307 1443, or email: CN.Doccheck@sgs.com

SGS-CTD Standards Technical Services Co., Ltd.
Guangzhou Chemical Laboratory

198 Kezhu Road, Sciencetech Park Guangzhou Economic & Technology Development District, Guangzhou, China 510663 t (86-20) 82155555 f (86-20) 82075113 www.sgsgroup.com.cn
中国·广州·经济技术开发区科学城科珠路198号 邮编: 510663 t (86-20) 82155555 f (86-20) 82075113 e sgs.china@sgs.com

ATTACHMENTS

RoHS Testing Flow Chart

- 1) Name of the person who made testing: Bruce Xiao / Sunny Hu
- 2) Name of the person in charge of testing: Bella Wang / Cutey Yu
- 3) These samples were dissolved totally by pre-conditioning method according to below flow chart (Cr⁶⁺ and PBBs/PBDEs test method excluded).

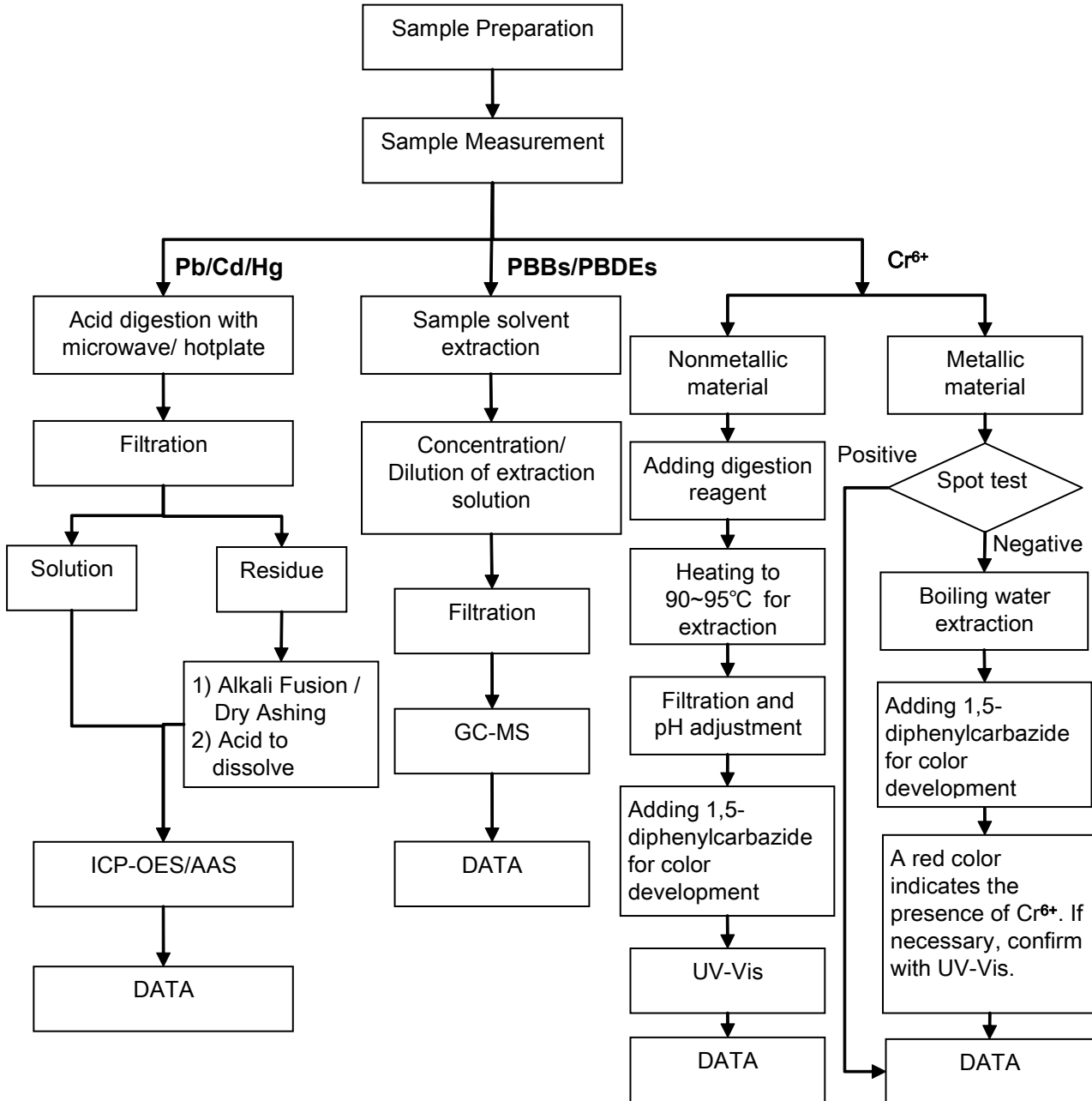

This document is issued by the Company subject to its General Conditions of Service printed overleaf, available on request or accessible at <http://www.sgs.com/en/Terms-and-Conditions.aspx> and, for electronic format documents, subject to Terms and Conditions for Electronic Documents at <http://www.sgs.com/en/Terms-and-Conditions/Terms-e-Documents.aspx>. Attention is drawn to the limitation of liability, indemnification and jurisdiction issues defined therein. Any holder of this document is advised that information contained herein reflects the Company's findings at the time of its intervention only and within the limits of Client's instructions, if any. The Company's sole responsibility is to its Client and this document does not exonerate parties to a transaction from exercising all their rights and obligations under the transaction documents. This document cannot be reproduced except in full, without prior written approval of the Company. Any unauthorized alteration, forgery or falsification of the content or appearance of this document is unlawful and offenders may be prosecuted to the fullest extent of the law. Unless otherwise stated the results shown in this test report refer only to the sample(s) tested.

Attention: To check the authenticity of testing / inspection report & certificate, please contact us at telephone: (86-755) 8307 1443, or email: CN.Doccheck@sgs.com

198 Kezhu Road, Sciencetech Park Guangzhou Economic & Technology Development District, Guangzhou, China 510663 t (86-20) 82155555 f (86-20) 82075113 www.sgsgroup.com.cn
中国·广州·经济技术开发区科学城科珠路198号 邮编: 510663 t (86-20) 82155555 f (86-20) 82075113 e sgs.china@sgs.com

ATTACHMENTS

HBCDD Testing Flow Chart

- 1) Name of the person who made testing: Sunny Hu
- 2) Name of the person in charge of testing: Cutey Yu

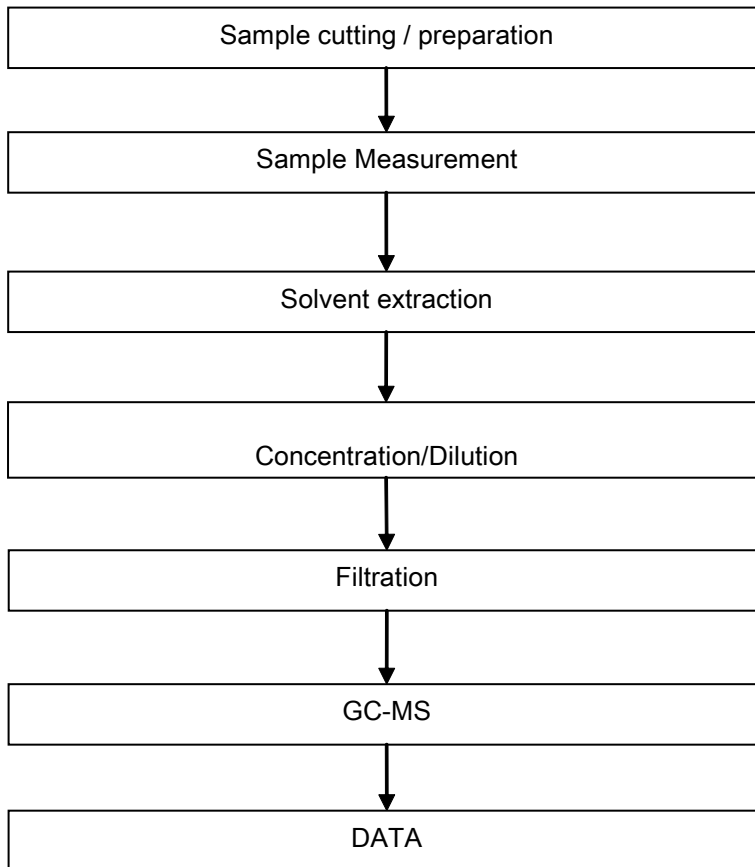

This document is issued by the Company subject to its General Conditions of Service printed overleaf, available on request or accessible at <http://www.sgs.com/en/Terms-and-Conditions.aspx> and, for electronic format documents, subject to Terms and Conditions for Electronic Documents at <http://www.sgs.com/en/Terms-and-Conditions/Terms-e-Documents.aspx>. Attention is drawn to the limitation of liability, indemnification and jurisdiction issues defined therein. Any holder of this document is advised that information contained hereon reflects the Company's findings at the time of its intervention only and within the limits of Client's instructions, if any. The Company's sole responsibility is to its Client and this document does not exonerate parties to a transaction from exercising all their rights and obligations under the transaction documents. This document cannot be reproduced except in full, without prior written approval of the Company. Any unauthorized alteration, forgery or falsification of the content or appearance of this document is unlawful and offenders may be prosecuted to the fullest extent of the law. Unless otherwise stated the results shown in this test report refer only to the sample(s) tested.

Attention: To check the authenticity of testing / inspection report & certificate, please contact us at telephone: (86-755) 8307 1443, or email: CN.Doccheck@sgs.com

198 Kezhu Road, Sciencetech Park Guangzhou Economic & Technology Development District, Guangzhou, China 510663 t (86-20) 82155555 f (86-20) 82075113 www.sgsgroup.com.cn
中国·广州·经济技术开发区科学城科珠路198号 邮编: 510663 t (86-20) 82155555 f (86-20) 82075113 e sgs.china@sgs.com

ATTACHMENTS

Phthalates Testing Flow Chart

- 1) Name of the person who made testing: Sunny Hu
- 2) Name of the person in charge of testing: Cutey Yu

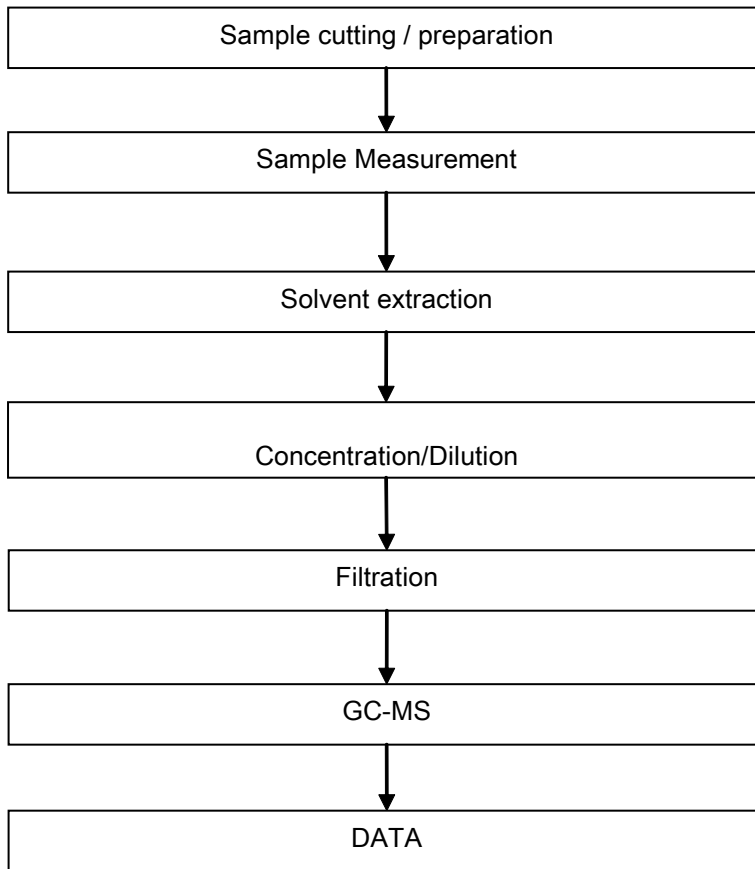

This document is issued by the Company subject to its General Conditions of Service printed overleaf, available on request or accessible at <http://www.sgs.com/en/Terms-and-Conditions.aspx> and, for electronic format documents, subject to Terms and Conditions for Electronic Documents at <http://www.sgs.com/en/Terms-and-Conditions/Terms-e-Documents.aspx>. Attention is drawn to the limitation of liability, indemnification and jurisdiction issues defined therein. Any holder of this document is advised that information contained hereon reflects the Company's findings at the time of its intervention only and within the limits of Client's instructions, if any. The Company's sole responsibility is to its Client and this document does not exonerate parties to a transaction from exercising all their rights and obligations under the transaction documents. This document cannot be reproduced except in full, without prior written approval of the Company. Any unauthorized alteration, forgery or falsification of the content or appearance of this document is unlawful and offenders may be prosecuted to the fullest extent of the law. Unless otherwise stated the results shown in this test report refer only to the sample(s) tested.

Attention: To check the authenticity of testing / inspection report & certificate, please contact us at telephone: (86-755) 8307 1443, or email: CN.Doccheck@sgs.com

Sample photo:



SGS authenticate the photo on original report only

*** End of Report ***

測試報告

Test Report

號碼(No.) : CE/2014/92356

日期(Date) : 2014/09/17

頁數(Page): 1 of 10

喬越實業有限公司

SIL-MORE INDUSTRIAL LTD.

新北市三重區興德路100號16樓

16F, NO. 100, XINGDE RD., SANCHONG DISTRICT, NEW TAIPEI CITY 24158, TAIWAN



以下測試樣品係由申請廠商所提供及確認 (The following sample(s) was/were submitted and identified by/on behalf of the applicant as) :

樣品名稱(Sample Description) : DOW CORNING TC-1996 THERMALLY CONDUCTIVE COMPOUND

收件日期(Sample Receiving Date) : 2014/09/11

測試期間(Testing Period) : 2014/09/11 TO 2014/09/17

=====
測試結果(Test Results) : 請見下一頁 (Please refer to next pages).



Troy Chang, Manager - Tech
Signed for and on behalf of
SGS TAIWAN LTD.
Chemical Laboratory - Taipei

This document is issued by the Company subject to its General Conditions of Service printed overleaf, available on request or accessible at <http://www.sgs.com/en/Terms-and-Conditions.aspx> and, for electronic format documents, subject to Terms and Conditions for Electronic Documents at <http://www.sgs.com/en/Terms-and-Conditions/Termse-Documents.aspx>. Attention is drawn to the limitation of liability, indemnification and jurisdiction issues defined therein. Any holder of this document is advised that information contained hereon reflects the Company's findings at the time of its intervention only and within the limits of client's instruction, if any. The Company's sole responsibility is to its Client and this document does not exonerate parties to a transaction from exercising all their rights and obligations under the transaction documents. This document cannot be reproduced, except in full, without prior written approval of the Company. Any unauthorized alteration, forgery or falsification of the content or appearance of this document is unlawful and offenders may be prosecuted to the fullest extent of the law. Unless otherwise stated the results shown in this test report refer only to the sample(s) tested.

測試報告

Test Report

號碼(No.) : CE/2014/92356

日期(Date) : 2014/09/17

頁數(Page): 2 of 10

喬越實業有限公司

SIL-MORE INDUSTRIAL LTD.

新北市三重區興德路100號16樓

16F, NO. 100, XINGDE RD., SANCHONG DISTRICT, NEW TAIPEI CITY 24158, TAIWAN



測試結果(Test Results)

測試部位(PART NAME)No.1 : 灰色膏狀 (GRAY PASTE)

測試項目 (Test Items)	單位 (Unit)	測試方法 (Method)	方法偵測 極限值 (MDL)	結果 (Result)
				No.1
鎘 / Cadmium (Cd)	mg/kg	參考IEC 62321-5: 2013方法, 以感應 耦合電漿原子發射光譜儀檢測. / With reference to IEC 62321-5: 2013 and performed by ICP-AES.	2	n.d.
鉛 / Lead (Pb)	mg/kg	參考IEC 62321-5: 2013方法, 以感應 耦合電漿原子發射光譜儀檢測. / With reference to IEC 62321-5: 2013 and performed by ICP-AES.	2	n.d.
汞 / Mercury (Hg)	mg/kg	參考IEC 62321-4: 2013方法, 以感應 耦合電漿原子發射光譜儀檢測. / With reference to IEC 62321-4: 2013 and performed by ICP-AES.	2	n.d.
六價鉻 / Hexavalent Chromium Cr(VI)	mg/kg	參考IEC 62321: 2008方法, 以UV-VIS 檢測. / With reference to IEC 62321: 2008 and performed by UV- VIS.	2	n.d.
六溴環十二烷及所有主要被辨別出的異構物 / Hexabromocyclododecane (HBCDD) and all major diastereoisomers identified (α - HBCDD, β - HBCDD, γ - HBCDD) (CAS No.: 25637-99-4 and 3194-55-6 (134237-51-7, 134237-50-6, 134237-52-8))	mg/kg	參考IEC 62321: 2008方法, 以氣相層 析/質譜儀檢測. / With reference to IEC 62321: 2008 method. Analysis was performed by GC/MS.	5	n.d.
鄰苯二甲酸丁苯甲酯 / BBP (Butyl Benzyl phthalate) (CAS No.: 85-68-7)	%	參考EN 14372, 以氣相層析/質譜儀檢 測. / With reference to EN 14372. Analysis was performed by GC/MS.	0.003	n.d.

This document is issued by the Company subject to its General Conditions of Service printed overleaf, available on request or accessible at <http://www.sgs.com/en/Terms-and-Conditions.aspx> and, for electronic format documents, subject to Terms and Conditions for Electronic Documents at <http://www.sgs.com/en/Terms-and-Conditions/Termse-Documents.aspx>. Attention is drawn to the limitation of liability, indemnification and jurisdiction issues defined therein. Any holder of this document is advised that information contained hereon reflects the Company's findings at the time of its intervention only and within the limits of client's instruction, if any. The Company's sole responsibility is to its Client and this document does not exonerate parties to a transaction from exercising all their rights and obligations under the transaction documents. This document cannot be reproduced, except in full, without prior written approval of the Company. Any unauthorized alteration, forgery or falsification of the content or appearance of this document is unlawful and offenders may be prosecuted to the fullest extent of the law. Unless otherwise stated the results shown in this test report refer only to the sample(s) tested.

測試報告 Test Report

號碼(No.) : CE/2014/92356

日期(Date) : 2014/09/17

頁數(Page): 3 of 10

喬越實業有限公司

SIL-MORE INDUSTRIAL LTD.

新北市三重區興德路100號16樓

16F, NO. 100, XINGDE RD., SANCHONG DISTRICT, NEW TAIPEI CITY 24158, TAIWAN



測試項目 (Test Items)	單位 (Unit)	測試方法 (Method)	方法偵測 極限值 (MDL)	結果 (Result)
				No.1
鄰苯二甲酸二丁酯 / DBP (Dibutyl phthalate) (CAS No.: 84-74-2)	%	參考EN 14372, 以氣相層析/質譜儀檢測. / With reference to EN 14372. Analysis was performed by GC/MS.	0.003	n.d.
鄰苯二甲酸二(2-乙基己基)酯 / DEHP (Di-(2-ethylhexyl) phthalate) (CAS No.: 117-81-7)	%	參考EN 14372, 以氣相層析/質譜儀檢測. / With reference to EN 14372. Analysis was performed by GC/MS.	0.003	n.d.
鄰苯二甲酸二異丁酯 / DIBP (Di-isobutyl phthalate) (CAS No.: 84-69-5)	%	參考EN 14372, 以氣相層析/質譜儀檢測. / With reference to EN 14372. Analysis was performed by GC/MS.	0.003	n.d.
多溴聯苯總和 / Sum of PBBs	mg/kg	參考IEC 62321: 2008方法, 以氣相層析/質譜儀檢測. / With reference to IEC 62321: 2008 and performed by GC/MS.	-	n.d.
一溴聯苯 / Monobromobiphenyl			5	n.d.
二溴聯苯 / Dibromobiphenyl			5	n.d.
三溴聯苯 / Tribromobiphenyl			5	n.d.
四溴聯苯 / Tetrabromobiphenyl			5	n.d.
五溴聯苯 / Pentabromobiphenyl			5	n.d.
六溴聯苯 / Hexabromobiphenyl			5	n.d.
七溴聯苯 / Heptabromobiphenyl			5	n.d.
八溴聯苯 / Octabromobiphenyl			5	n.d.
九溴聯苯 / Nonabromobiphenyl			5	n.d.
十溴聯苯 / Decabromobiphenyl			5	n.d.
多溴聯苯醚總和 / Sum of PBDEs			-	n.d.
一溴聯苯醚 / Monobromodiphenyl ether			5	n.d.
二溴聯苯醚 / Dibromodiphenyl ether			5	n.d.
三溴聯苯醚 / Tribromodiphenyl ether			5	n.d.
四溴聯苯醚 / Tetrabromodiphenyl ether			5	n.d.
五溴聯苯醚 / Pentabromodiphenyl ether			5	n.d.
六溴聯苯醚 / Hexabromodiphenyl ether			5	n.d.
七溴聯苯醚 / Heptabromodiphenyl ether			5	n.d.
八溴聯苯醚 / Octabromodiphenyl ether			5	n.d.
九溴聯苯醚 / Nonabromodiphenyl ether	5	n.d.		
十溴聯苯醚 / Decabromodiphenyl ether	5	n.d.		

This document is issued by the Company subject to its General Conditions of Service printed overleaf, available on request or accessible at <http://www.sgs.com/en/Terms-and-Conditions.aspx> and, for electronic format documents, subject to Terms and Conditions for Electronic Documents at <http://www.sgs.com/en/Terms-and-Conditions/Termse-Document.aspx>. Attention is drawn to the limitation of liability, indemnification and jurisdiction issues defined therein. Any holder of this document is advised that information contained hereon reflects the Company's findings at the time of its intervention only and within the limits of client's instruction, if any. The Company's sole responsibility is to its Client and this document does not exonerate parties to a transaction from exercising all their rights and obligations under the transaction documents. This document cannot be reproduced, except in full, without prior written approval of the Company. Any unauthorized alteration, forgery or falsification of the content or appearance of this document is unlawful and offenders may be prosecuted to the fullest extent of the law. Unless otherwise stated the results shown in this test report refer only to the sample(s) tested.

測試報告

Test Report

號碼(No.) : CE/2014/92356

日期(Date) : 2014/09/17

頁數(Page): 4 of 10

喬越實業有限公司



SIL-MORE INDUSTRIAL LTD.

新北市三重區興德路100號16樓

16F, NO. 100, XINGDE RD., SANCHONG DISTRICT, NEW TAIPEI CITY 24158, TAIWAN

測試項目 (Test Items)	單位 (Unit)	測試方法 (Method)	方法偵測 極限值 (MDL)	結果 (Result)
				No.1
鹵素 / Halogen				
鹵素 (氟) / Halogen-Fluorine (F) (CAS No.: 14762-94-8)	mg/kg	參考BS EN 14582:2007, 以離子層析儀 分析. / With reference to BS EN 14582:2007. Analysis was performed by IC.	50	n.d.
鹵素 (氯) / Halogen-Chlorine (Cl) (CAS No.: 22537-15-1)			50	n.d.
鹵素 (溴) / Halogen-Bromine (Br) (CAS No.: 10097-32-2)			50	n.d.
鹵素 (碘) / Halogen-Iodine (I) (CAS No.: 14362-44-8)			50	n.d.

備註(Note) :

1. mg/kg = ppm ; 0.1wt% = 1000ppm
2. n.d. = Not Detected (未檢出)
3. MDL = Method Detection Limit (方法偵測極限值)
4. "-" = Not Regulated (無規格值)

測試報告 Test Report

號碼(No.) : CE/2014/92356

日期(Date) : 2014/09/17

頁數(Page): 5 of 10

喬越實業有限公司

SIL-MORE INDUSTRIAL LTD.

新北市三重區興德路100號16樓

16F, NO. 100, XINGDE RD., SANCHONG DISTRICT, NEW TAIPEI CITY 24158, TAIWAN



- 1) 根據以下的流程圖之條件，樣品已完全溶解。(六價鉻測試方法除外) / These samples were dissolved totally by pre-conditioning method according to below flow chart. (Cr⁶⁺ test method excluded)
- 2) 測試人員：楊登偉 / Name of the person who made measurement: Climbgreat Yang
- 3) 測試負責人：張啓興 / Name of the person in charge of measurement: Troy Chang

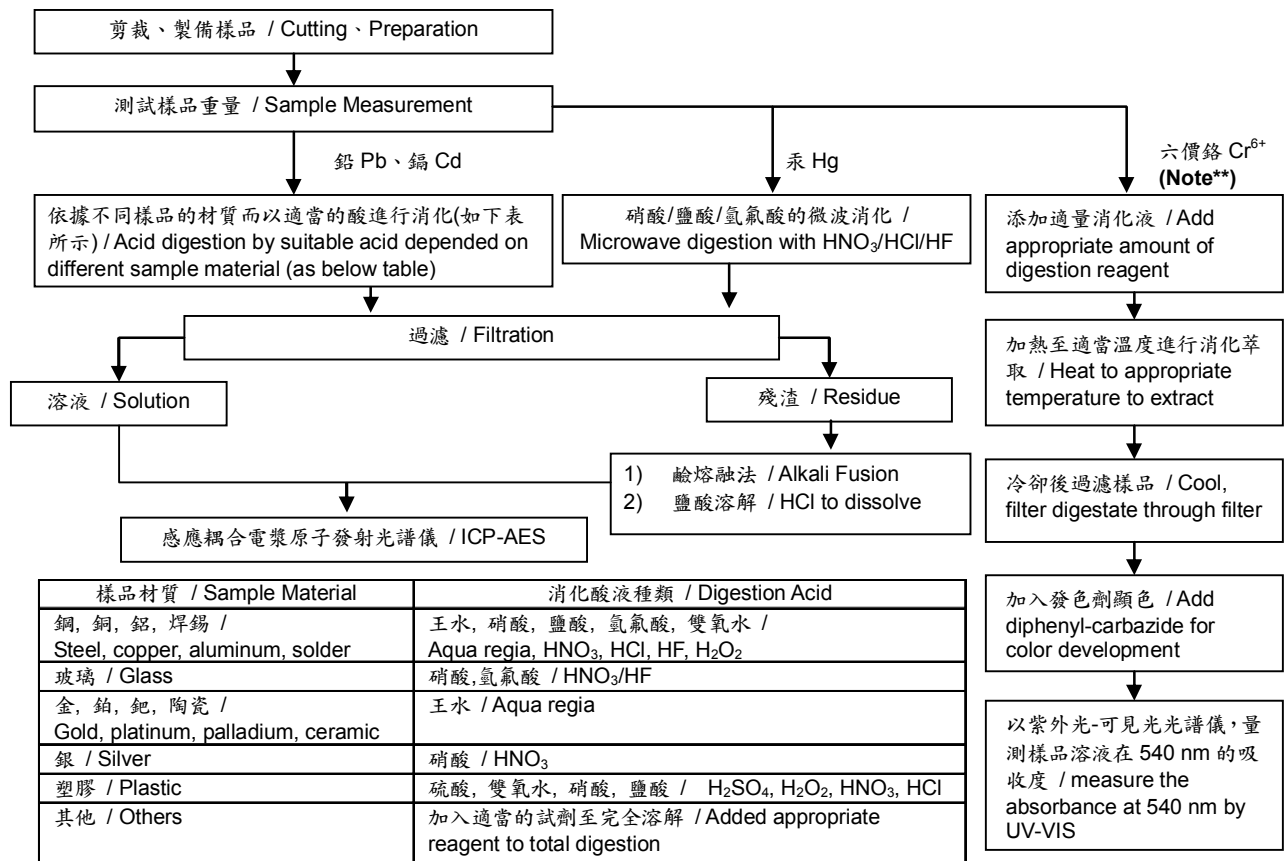

Note** (For IEC 62321)

- (1) 針對非金屬材料加入鹼性消化液，加熱至 90~95°C 萃取。 / For non-metallic material, add alkaline digestion reagent and heat to 90~95°C.
- (2) 針對金屬材料加入純水，加熱至沸騰萃取。 / For metallic material, add pure water and heat to boiling.

測試報告 Test Report

號碼(No.) : CE/2014/92356

日期(Date) : 2014/09/17

頁數(Page): 6 of 10

喬越實業有限公司

SIL-MORE INDUSTRIAL LTD.

新北市三重區興德路100號16樓

16F, NO. 100, XINGDE RD., SANCHONG DISTRICT, NEW TAIPEI CITY 24158, TAIWAN



可塑劑分析流程圖 / Analytical flow chart of phthalate content

- 測試人員：翁賜彬 / Name of the person who made measurement: Roman Wong
- 測試負責人：張啓興 / Name of the person in charge of measurement: Troy Chang

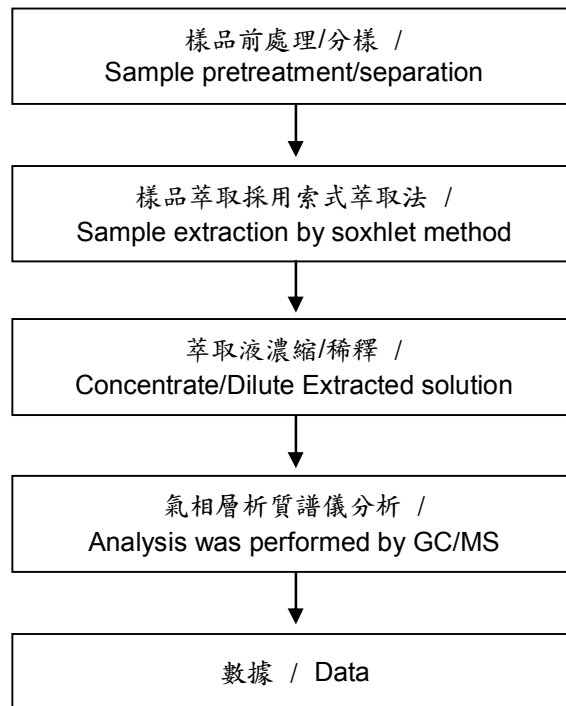

測試報告 Test Report

號碼(No.) : CE/2014/92356

日期(Date) : 2014/09/17

頁數(Page): 7 of 10

喬越實業有限公司

SIL-MORE INDUSTRIAL LTD.

新北市三重區興德路100號16樓

16F, NO. 100, XINGDE RD., SANCHONG DISTRICT, NEW TAIPEI CITY 24158, TAIWAN



六溴環十二烷分析流程圖 / HBCDD analytical flow chart

- 測試人員：翁賜彬 / Name of the person who made measurement: Roman Wong
- 測試負責人：張啓興 / Name of the person in charge of measurement: Troy Chang

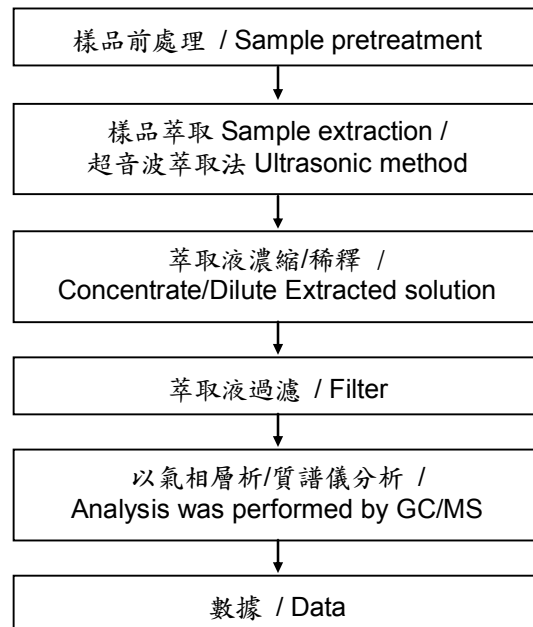

測試報告 Test Report

號碼(No.) : CE/2014/92356

日期(Date) : 2014/09/17

頁數(Page): 8 of 10

喬越實業有限公司

SIL-MORE INDUSTRIAL LTD.

新北市三重區興德路100號16樓

16F, NO. 100, XINGDE RD., SANCHONG DISTRICT, NEW TAIPEI CITY 24158, TAIWAN



鹵素分析流程圖 / Analytical flow chart of halogen content

- 測試人員：陳思臻 / Name of the person who made measurement: Rita Chen
- 測試負責人：張啓興 / Name of the person in charge of measurement: Troy Chang

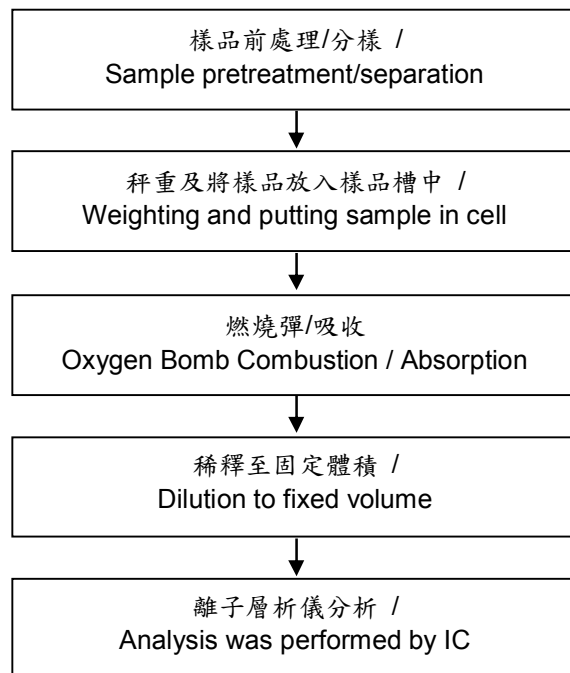

測試報告 Test Report

號碼(No.) : CE/2014/92356

日期(Date) : 2014/09/17

頁數(Page): 9 of 10

喬越實業有限公司

SIL-MORE INDUSTRIAL LTD.

新北市三重區興德路100號16樓

16F, NO. 100, XINGDE RD., SANCHONG DISTRICT, NEW TAIPEI CITY 24158, TAIWAN



多溴聯苯/多溴聯苯醚分析流程圖 / PBB/PBDE analytical FLOW CHART

- 測試人員：翁賜彬 / Name of the person who made measurement: Roman Wong
 - 測試負責人：張啓興 / Name of the person in charge of measurement: Troy Chang
- 初次測試程序 / First testing process —————>
- 選擇性篩檢程序 / Optional screen process>
- 確認程序 / Confirmation process - - ->

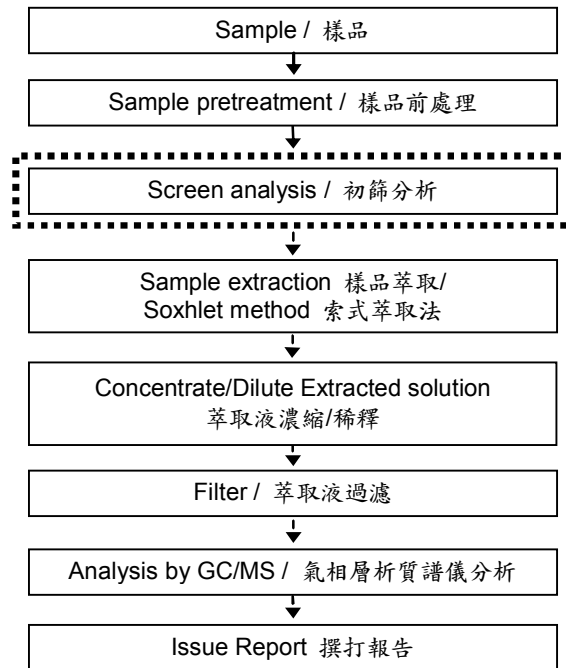

This document is issued by the Company subject to its General Conditions of Service printed overleaf, available on request or accessible at <http://www.sgs.com/en/Terms-and-Conditions.aspx> and, for electronic format documents, subject to Terms and Conditions for Electronic Documents at <http://www.sgs.com/en/Terms-and-Conditions/Termse-Documents.aspx>. Attention is drawn to the limitation of liability, indemnification and jurisdiction issues defined therein. Any holder of this document is advised that information contained hereon reflects the Company's findings at the time of its intervention only and within the limits of client's instruction, if any. The Company's sole responsibility is to its Client and this document does not exonerate parties to a transaction from exercising all their rights and obligations under the transaction documents. This document cannot be reproduced, except in full, without prior written approval of the Company. Any unauthorized alteration, forgery or falsification of the content or appearance of this document is unlawful and offenders may be prosecuted to the fullest extent of the law. Unless otherwise stated the results shown in this test report refer only to the sample(s) tested.

測試報告 Test Report

號碼(No.) : CE/2014/92356

日期(Date) : 2014/09/17

頁數(Page): 10 of 10

喬越實業有限公司

SIL-MORE INDUSTRIAL LTD.

新北市三重區興德路100號16樓

16F, NO. 100, XINGDE RD., SANCHONG DISTRICT, NEW TAIPEI CITY 24158, TAIWAN



* 照片中如有箭頭標示，則表示為實際檢測之樣品/部位。*
(The tested sample / part is marked by an arrow if it's shown on the photo.)

CE/2014/92356



** 報告結尾 (End of Report) **

This document is issued by the Company subject to its General Conditions of Service printed overleaf, available on request or accessible at <http://www.sgs.com/en/Terms-and-Conditions.aspx> and, for electronic format documents, subject to Terms and Conditions for Electronic Documents at <http://www.sgs.com/en/Terms-and-Conditions/Termse-Documents.aspx>. Attention is drawn to the limitation of liability, indemnification and jurisdiction issues defined therein. Any holder of this document is advised that information contained hereon reflects the Company's findings at the time of its intervention only and within the limits of client's instruction, if any. The Company's sole responsibility is to its Client and this document does not exonerate parties to a transaction from exercising all their rights and obligations under the transaction documents. This document cannot be reproduced, except in full, without prior written approval of the Company. Any unauthorized alteration, forgery or falsification of the content or appearance of this document is unlawful and offenders may be prosecuted to the fullest extent of the law. Unless otherwise stated the results shown in this test report refer only to the sample(s) tested.