

- 1 MATERIAL: HOUSING, BRACKET, ADAPTER COMB AND TERMINAL SUPPORT PLATE - POLYESTER BLACK.  
 BAIL CLIPS - PASSIVATED STAINLESS STEEL.  
 RECEPTACLE SHIELD - BRIGHT NICKEL OVER COPPER PLATED DIE CASTING.  
 TERMINALS - TAILS - TIN LEAD OVER NICKEL PLATED HIGH STRENGTH COPPER ALLOY.  
 MATING SURFACE - LOCALIZED GOLD OVER NICKEL PLATED HIGH STRENGTH COPPER ALLOY.  
 GROUND BRACKET - TIN-LEAD PLATED CARBON STEEL.
- 2 THE CONTACT SURFACES OF THE TERMINALS ARE COATED WITH LUBRICANT.
- 3 CENTER TO CENTER SPACING OF TERMINALS IS .085 NOMINAL.
- 4 ALL DIMENSIONS SHOWN ARE MAXIMUM UNLESS OTHERWISE SPECIFIED.
- 5 DETAIL A IS VIEWED FROM MATING SIDE OF RECEPTACLE ASSEMBLY.
- 6 SHIELD IS ASSEMBLED TO RECEPTACLE ASSEMBLY BEFORE SHIPMENT.
- 7 TERMINAL 1 LOCATED IN THIS ROW FOR STANDARD ORIENTATION. PANEL THICKNESS RANGE: .062 MAXIMUM.
- 8 GROUNDING BRACKET RETAINS CONNECTOR IN .062 THICK P.C. BOARD WITHOUT ADDITIONAL HARDWARE.
- 9 IF TERMINALS DO NOT EXTEND BELOW COMB, THEN COMB SHALL BE PARTIALLY RETRACTED BEFORE INSERTING CONNECTOR INTO P.C. BOARD.
- 10 GROUNDING BRACKET LOCATES CONNECTOR FLUSH WITH TOP OF P.C. BOARD AND SPRING LOCKS BENEATH.
- 11 CYLINDRICAL SHAPE OFFERS 180° OF SOLDERING SURFACE.
- 12 SURFACE AREA OF GROUNDING BRACKET BELOW P.C. BOARD SHALL PASS SOLIDABILITY REQUIREMENTS IN ACCORDANCE WITH AMP SPECIFICATION 109-11-2. DISCOLORATION, SCRATCHES, SPOTS AND OTHER COSMETIC DEFICIENCIES TYPICAL OF BARREL PLATING PROCESSES ARE ACCEPTABLE PROVIDING PARTS PASS 24 HOUR EXPOSURE AT 95% RH AT 40°C WITHOUT EVIDENCE OF CORROSION.
- 13 TERMINAL 1 LOCATED IN THIS ROW FOR REVERSE ORIENTATION.

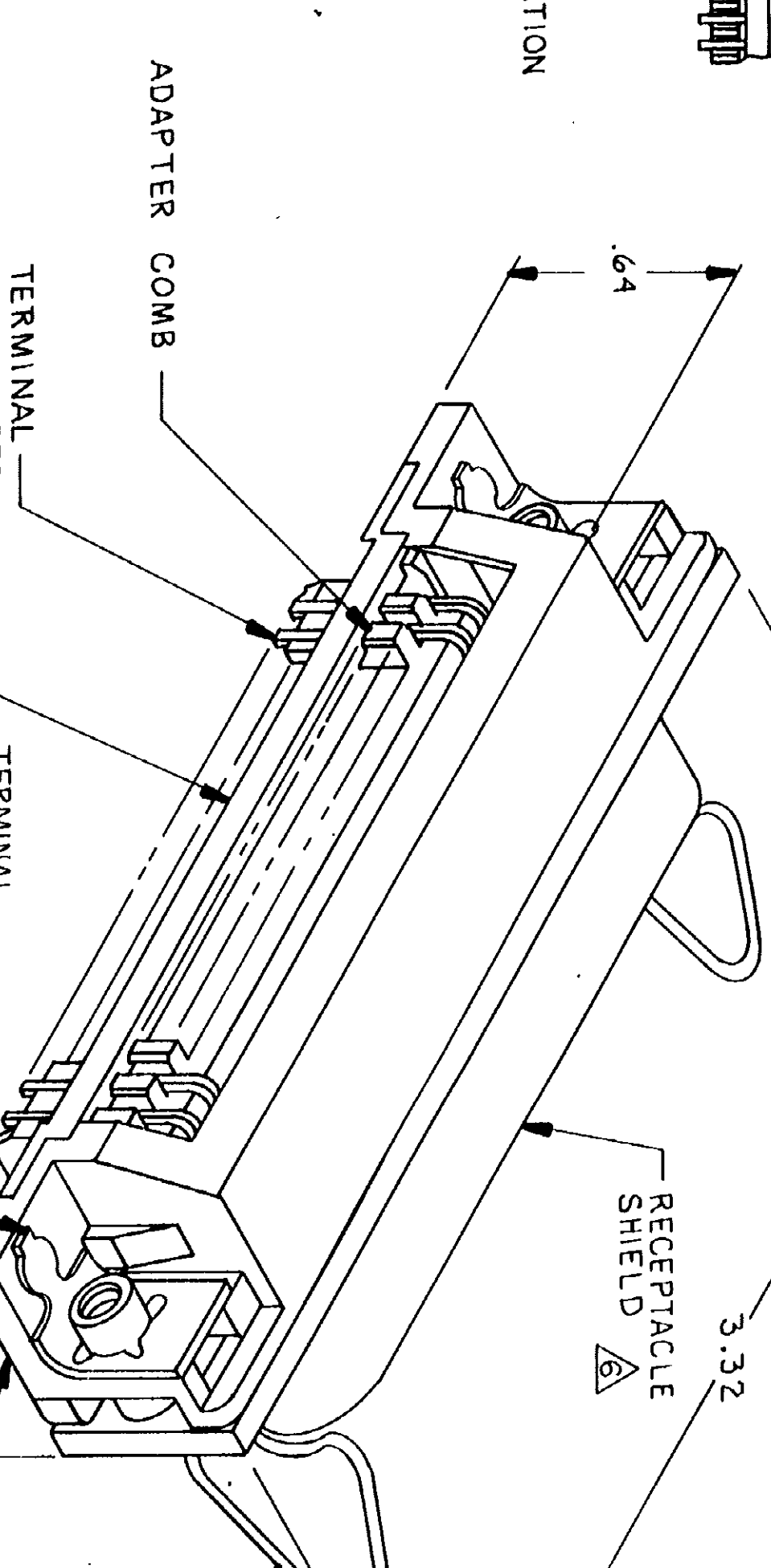

- 1 MATERIAL: HOUSING, BRACKET, ADAPTER COMB AND TERMINAL SUPPORT PLATE - POLYESTER BLACK.  
 BAIL CLIPS - PASSIVATED STAINLESS STEEL.  
 RECEPTACLE SHIELD - BRIGHT NICKEL OVER COPPER PLATED DIE CASTING.  
 TERMINALS - TAILS - TIN LEAD OVER NICKEL PLATED HIGH STRENGTH COPPER ALLOY.  
 MATING SURFACE - LOCALIZED GOLD OVER NICKEL PLATED HIGH STRENGTH COPPER ALLOY.  
 GROUND BRACKET - TIN-LEAD PLATED CARBON STEEL.
- 2 THE CONTACT SURFACES OF THE TERMINALS ARE COATED WITH LUBRICANT.
- 3 CENTER TO CENTER SPACING OF TERMINALS IS .085 NOMINAL.
- 4 ALL DIMENSIONS SHOWN ARE MAXIMUM UNLESS OTHERWISE SPECIFIED.
- 5 DETAIL A IS VIEWED FROM MATING SIDE OF RECEPTACLE ASSEMBLY.
- 6 SHIELD IS ASSEMBLED TO RECEPTACLE ASSEMBLY BEFORE SHIPMENT.
- 7 TERMINAL 1 LOCATED IN THIS ROW FOR STANDARD ORIENTATION. PANEL THICKNESS RANGE: .062 MAXIMUM.
- 8 GROUNDING BRACKET RETAINS CONNECTOR IN .062 THICK P.C. BOARD WITHOUT ADDITIONAL HARDWARE.
- 9 IF TERMINALS DO NOT EXTEND BELOW COMB, THEN COMB SHALL BE PARTIALLY RETRACTED BEFORE INSERTING CONNECTOR INTO P.C. BOARD.
- 10 GROUNDING BRACKET LOCATES CONNECTOR FLUSH WITH TOP OF P.C. BOARD AND SPRING LOCKS BENEATH.
- 11 CYLINDRICAL SHAPE OFFERS 180° OF SOLDERING SURFACE.
- 12 SURFACE AREA OF GROUNDING BRACKET BELOW P.C. BOARD SHALL PASS SOLIDABILITY REQUIREMENTS IN ACCORDANCE WITH AMP SPECIFICATION 109-11-2. DISCOLORATION, SCRATCHES, SPOTS AND OTHER COSMETIC DEFICIENCIES TYPICAL OF BARREL PLATING PROCESSES ARE ACCEPTABLE PROVIDING PARTS PASS 24 HOUR EXPOSURE AT 95% RH AT 40°C WITHOUT EVIDENCE OF CORROSION.
- 13 TERMINAL 1 LOCATED IN THIS ROW FOR REVERSE ORIENTATION.

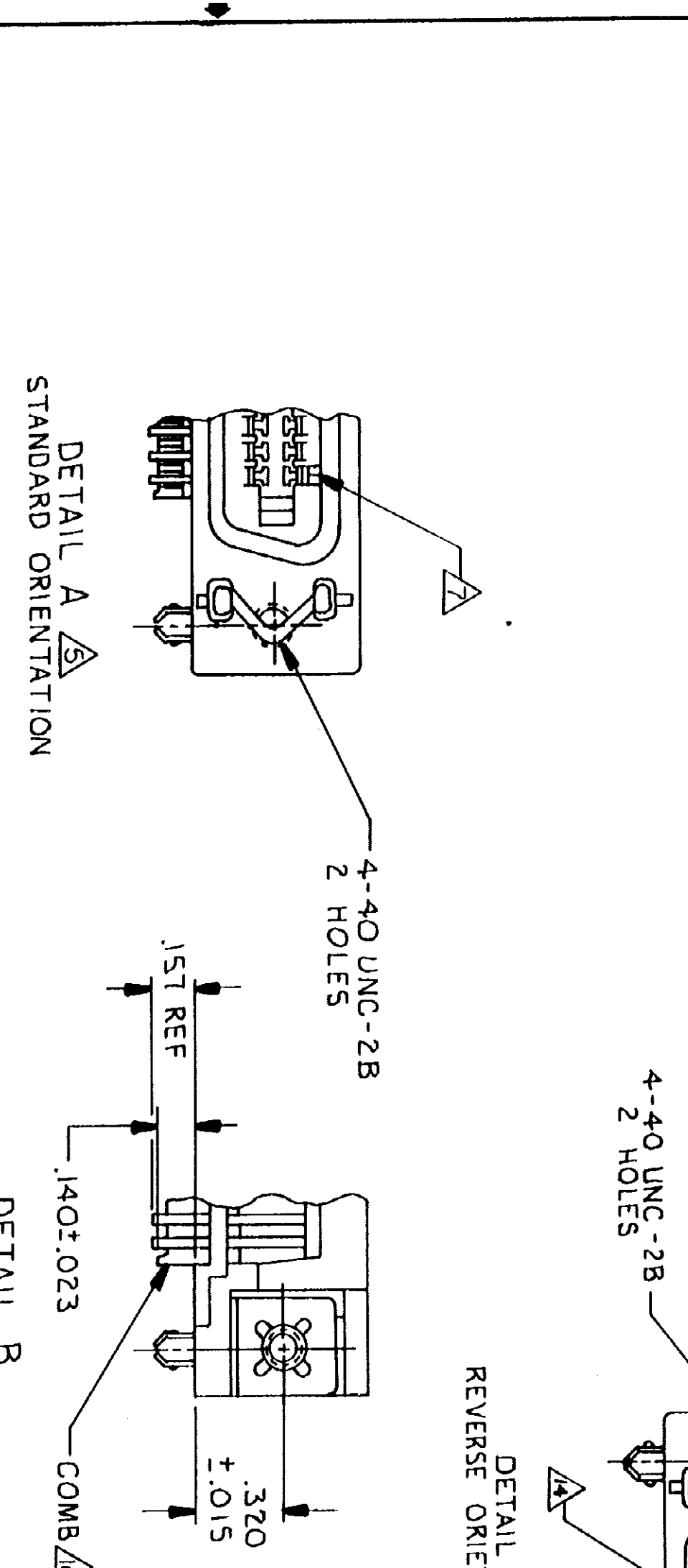
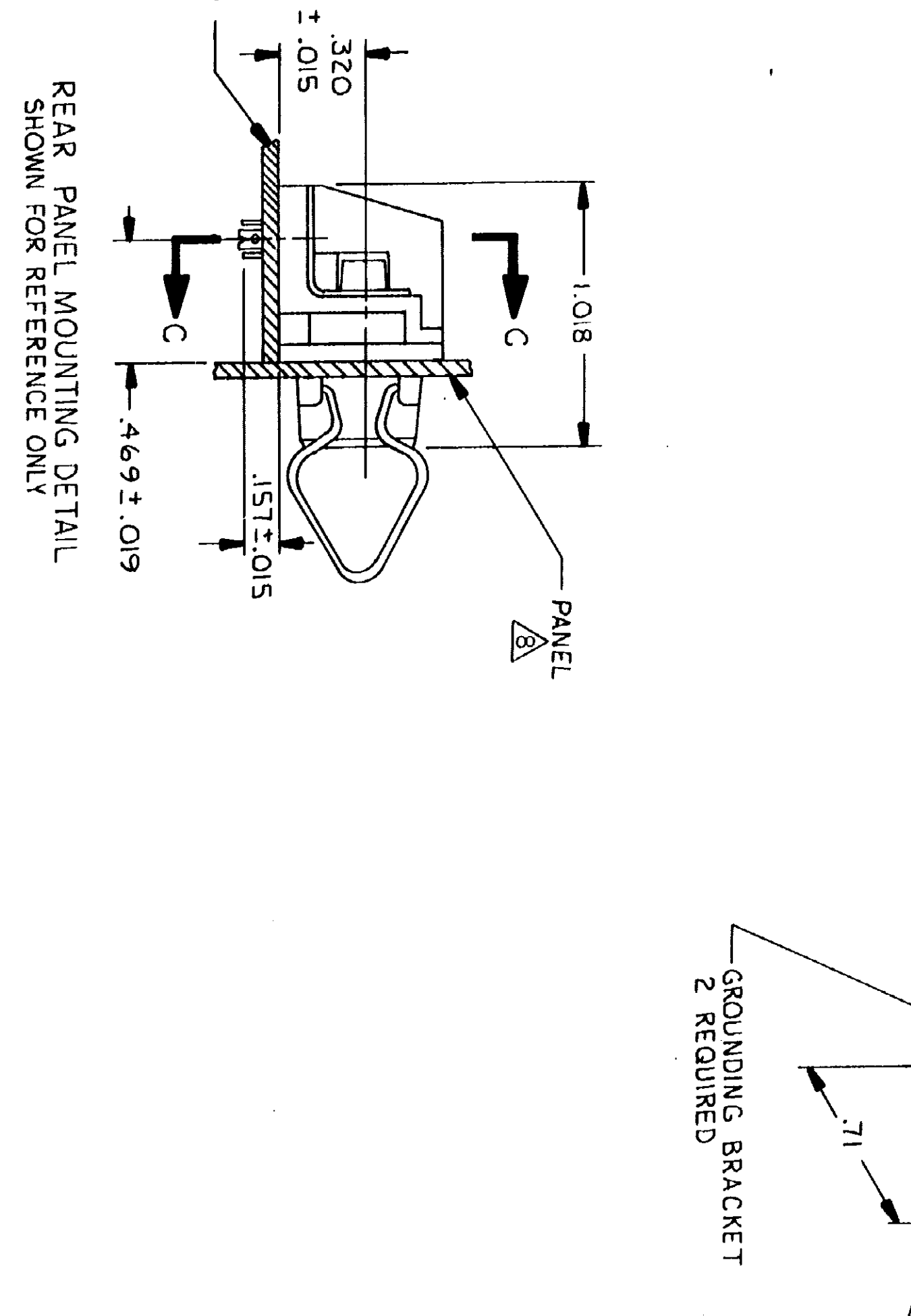
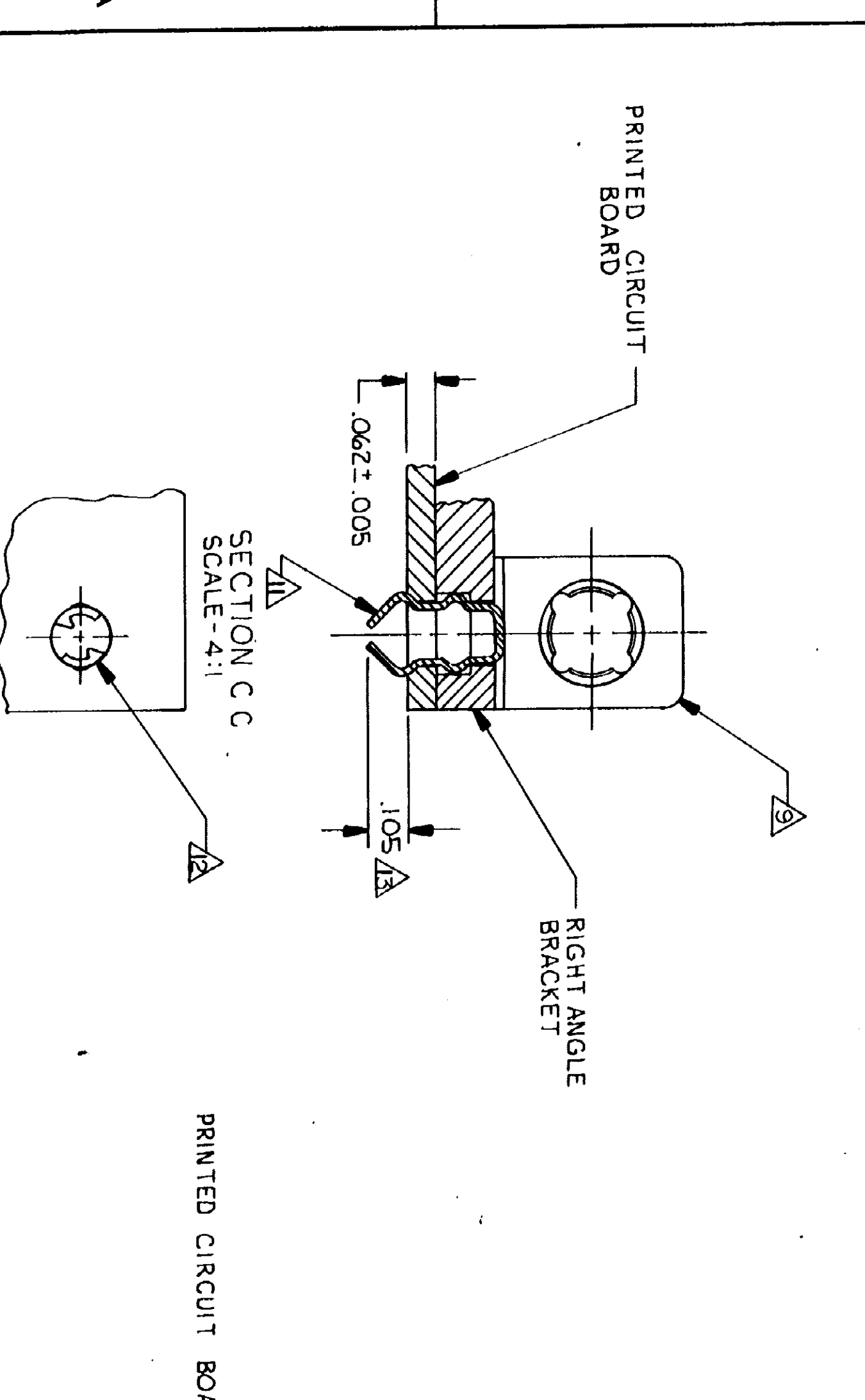

UNLESS OTHERWISE SPECIFIED DIMENSIONS ARE IN INCHES TOLERANCES ON: ANGLES: MATERIAL: FINISH: CONTRACT NO: DR C. Yates 9-29-86 CHS FOR 10-16-86 APPD [Signature] APPD [Signature] OTHER A.P.P.O. DSGN A.P.P.O. OTHER A.P.P.O.		NAME: RECEPTACLE ASSEMBLY, SHIELDED, 50 POSITION, RIGHT ANGLE, BAIL LOCK, FLUSH PANEL MOUNTING WITH BOARD LOCK GROUND, CHAMP	
SCALE: 2:1	SIZE: D	FSGM NO: 00779	DRAWING NO: 555057
DETAIL A STANDARD ORIENTATION		PART NO: 555057-1	