

REVISIONS					
P	LTR	DESCRIPTION	DATE	DWN	APVD
P4		REVISED PER ECN-22-156403	03JUN2022	RK	CSD

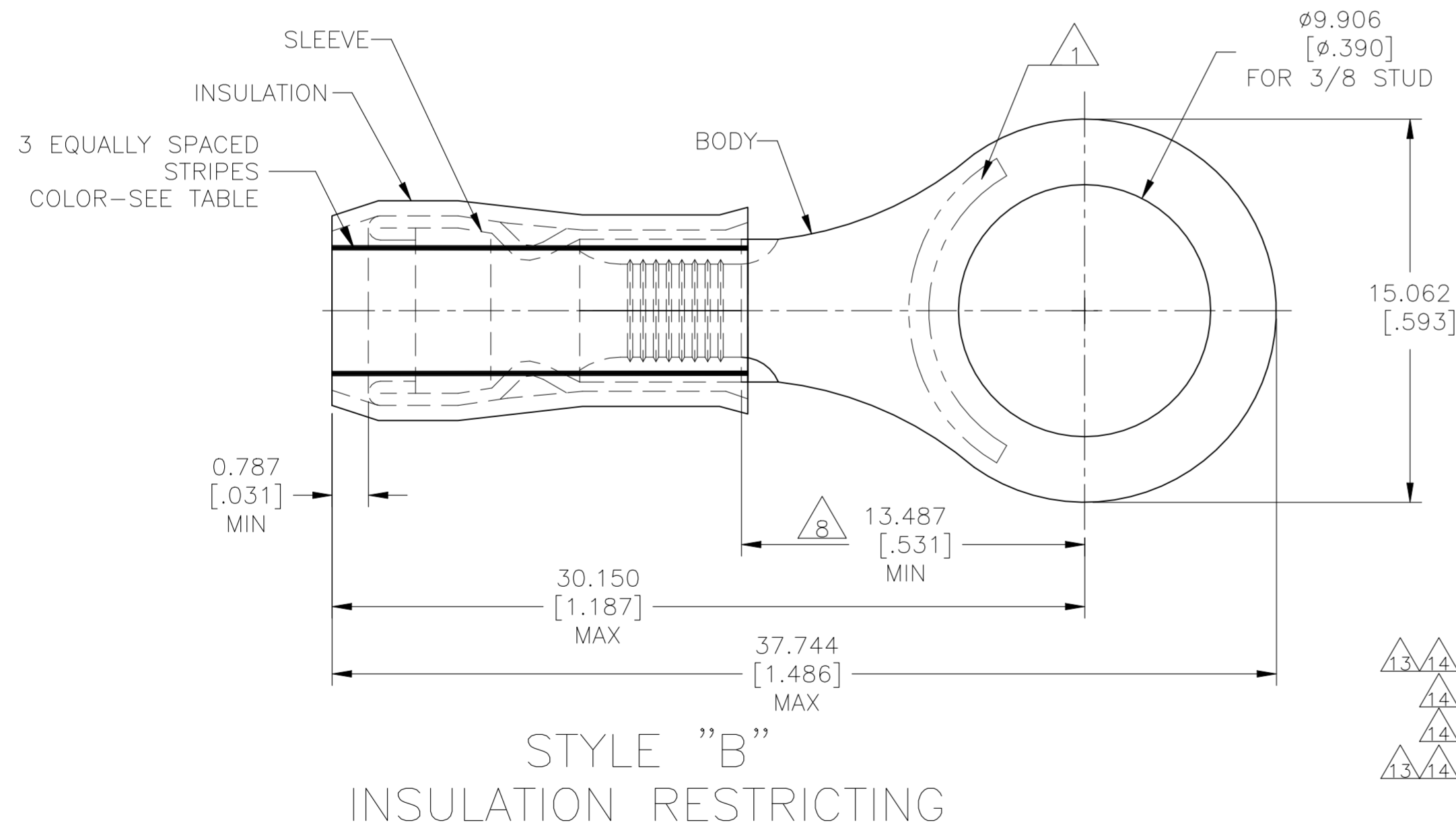
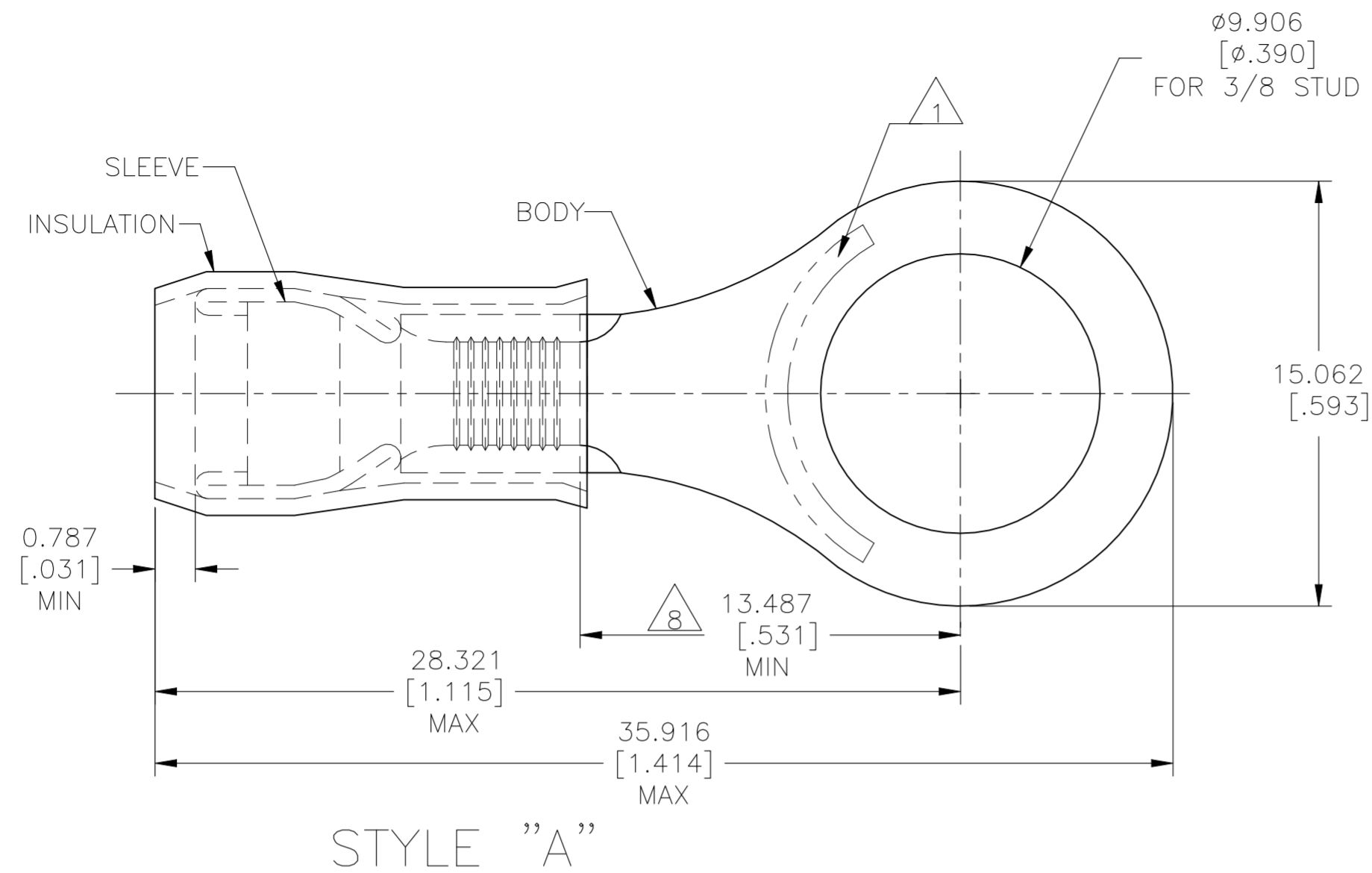

AMP WIRE RANGE	Listed FILE E13288	LR7189 Certified
12-10 AWG SOLID OR STRANDED IR: STRANDED	12-10 AWG STRANDED	12-10 AWG SOLID OR STRANDED IR: STRANDED

- STAMP "AMP - SEE TABLE" APPROX AS SHOWN
- WIRE INSULATION DIA: SEE TABLE.
- BODY MATERIAL THK: 1.016±0.051[.040±.002]
- FINISH:
BODY: TIN PLATE 0.00254[.000100] MIN EXT THK PER ASTM B545.
INSULATION: COLOR-YELLOW.
- FINISH:
SLEEVE: TIN PLATE 0.00254[.000100] MIN EXT THK PER ASTM B545.
INSULATION: COLOR-YELLOW.
- FINISH:
SLEEVE: NICKEL PLATE PER QQ-N-290.
INSULATION: COLOR-YELLOW.
- MATERIAL:
BODY & SLEEVE- CU PER ASTM B152
INSULATION - NYLON PER ASTM D4066.
- APPLIES FROM EDGE OF METAL WIRE BARREL
TO CENTER OF STUD HOLE.
- MEETS MS25036-114, CLASS 1.
- NOTE DELETED
- MEETS M7928/1-61, CLASS 1.
- MEETS M7928/1-68, CLASS 1.
- UL LISTED
- CSA CERTIFIED

QTY	PACKAGE TYPE	STAMPING	WIRE INSUL DIA	WIRE SIZE	STRIPE COLOR	STYLE	BODY FINISH	SLEEVE FINISH	PART NO
1000	ON TAPE & REEL	12-10*	Ø3.810-5.842[Ø.150-.230]	12-10	---	"A"			2-320577-3
500	LOOSE PIECE	10*	Ø3.027-5.100[Ø.119-.200]	10	BROWN	"B"			2-320577-2
500	LOOSE PIECE	12*	Ø2.413-5.100[Ø.095-.200]	12	YELLOW	"B"			2-320577-1
500	LOOSE PIECE	12-10*	Ø3.810-5.842[Ø.150-.230]	12-10	---	"A"			320577

CUSTOMER SERVICE SYSTEMS		MAX RECOMMENDED OPERATING TEMPERATURE: 105°C[221°F] MAX		THIS DRAWING IS A CONTROLLED DOCUMENT.		DWN JR RUTH 23DEC09		TE Connectivity			
FOR ADDITIONAL PRODUCT INFORMATION OR COPIES OF DRAWINGS AND TECHNICAL DOCUMENTS	PRODUCT INFORMATION CENTER 1-800-522-6752	VOLTAGE RATING: 300 VOLT MAX	DIMENSIONS: mm [INCHES]		TOLERANCES UNLESS OTHERWISE SPECIFIED: 0 PLC ± - 1 PLC ± - 2 PLC ± - 3 PLC ± 0.127[.005] 4 PLC ± - ANGLES ± -		CHK T MICHELUTTI 23DEC09		NAME UL 486 A-B		
FOR APPLICATION TOOLING INFORMATION	TOOLING ASSISTANCE CENTER 1-800-722-1111	CIRCULAR MIL AREA: 2.62-6.64mm²[5,180-13,100] STRANDED OR SOLID			APVD T MICHELUTTI 23DEC09		PRODUCT SPEC APPLICATION SPEC 114-2157		TERMINAL, RING TONGUE, PIDG (12-10 AWG) PIDG IR (12 & 10 AWG)		
FOR ORDER ENTRY	1-800-526-5142	MATERIAL	FINISH		WEIGHT -		SIZE A2		RESTRICTED TO -		
				CUSTOMER DRAWING		CAGE CODE 00779		DRAWING NO C-320577		SCALE 5:1	
						SHEET 1 of 1		REV P4			