

PART NUMBER  
SEE TABLE

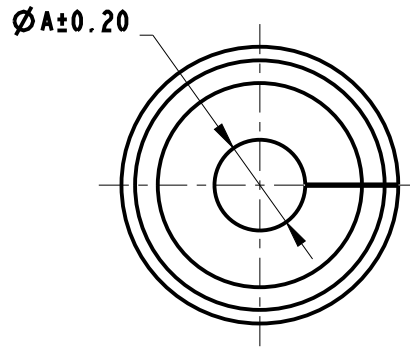
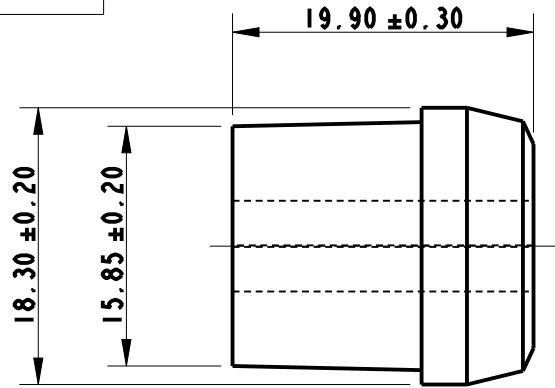

PART NUMBER	DIA A (mm)
10135739-001LF	10
10135739-002LF	7
10135739-003LF	9
10135739-004LF	6
10135739-005LF	8
10135739-006LF	11.5

NOTES:

1. MATERIAL: SILICONE
2. USE NEOPRENE GLOVES/FINGER CAPS WHILE HANDLING THE GLANDS.
3. STORE IN CLEAN AND DRY CONDITIONS.
4. ALL GLANDS SHOULD BE SPLIT.

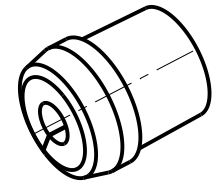

spec ref -		dr Alosius, Stali 2016/06/11		projection 	mm ←→	size A4	scale 1:1	
tolerance std ISO 406 ISO 1101		eng Alosius, Stali 2019/07/26				ecn no -		
TOLERANCES UNLESS OTHERWISE SPECIFIED		chr -				rel level Released		
surface 1.6		appr Varma Sudhir 2019/07/26		product family OCTIS			rev	
ISO 1302	linear	0.X	±0.3	Amphenol FCi			10135739	
		0.XX	±0.13					
	angular	0°	±°	RUBBER GLAND			A	
		cat. no. -		Product - Customer Drw			sheet 1 of 1	