

DRAWING MADE IN THIRD ANGLE PROJECTION

680164 680164

/home/comp16926/edmod

Table with 3 columns: PART NUMBER, REV, FIRST USED. Rows include 680164-1, 680164-2, 680164-3.

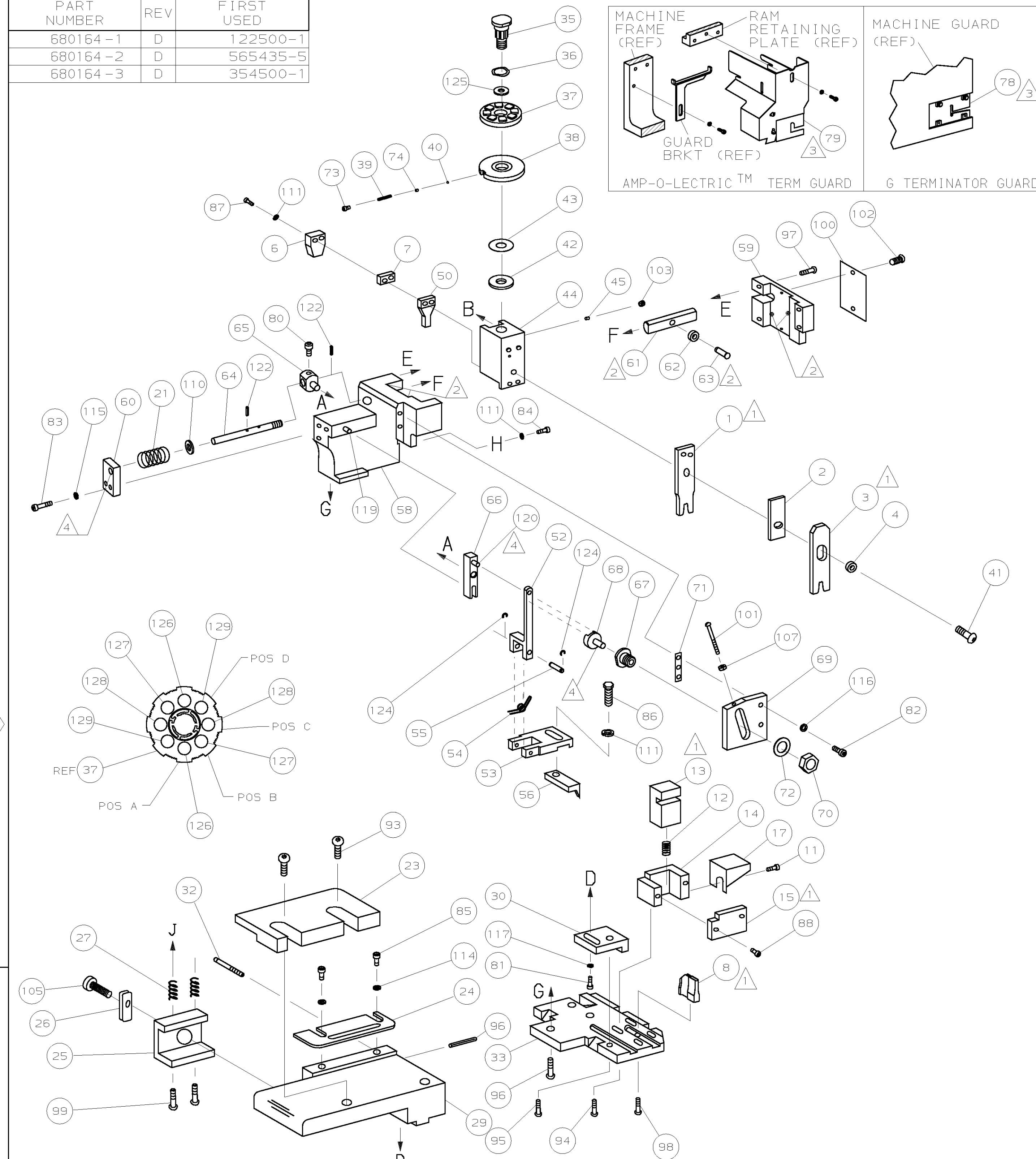

POST FEED 1 5/8 STROKE PRE FEED 1 1/8 STROKE PRE FEED 1 5/8 STROKE

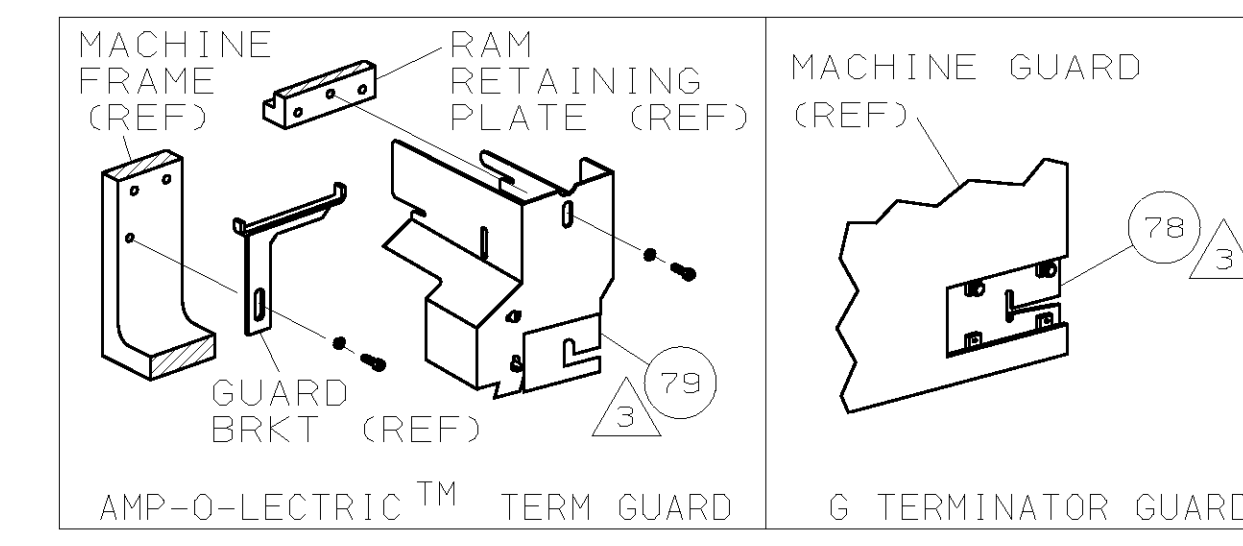
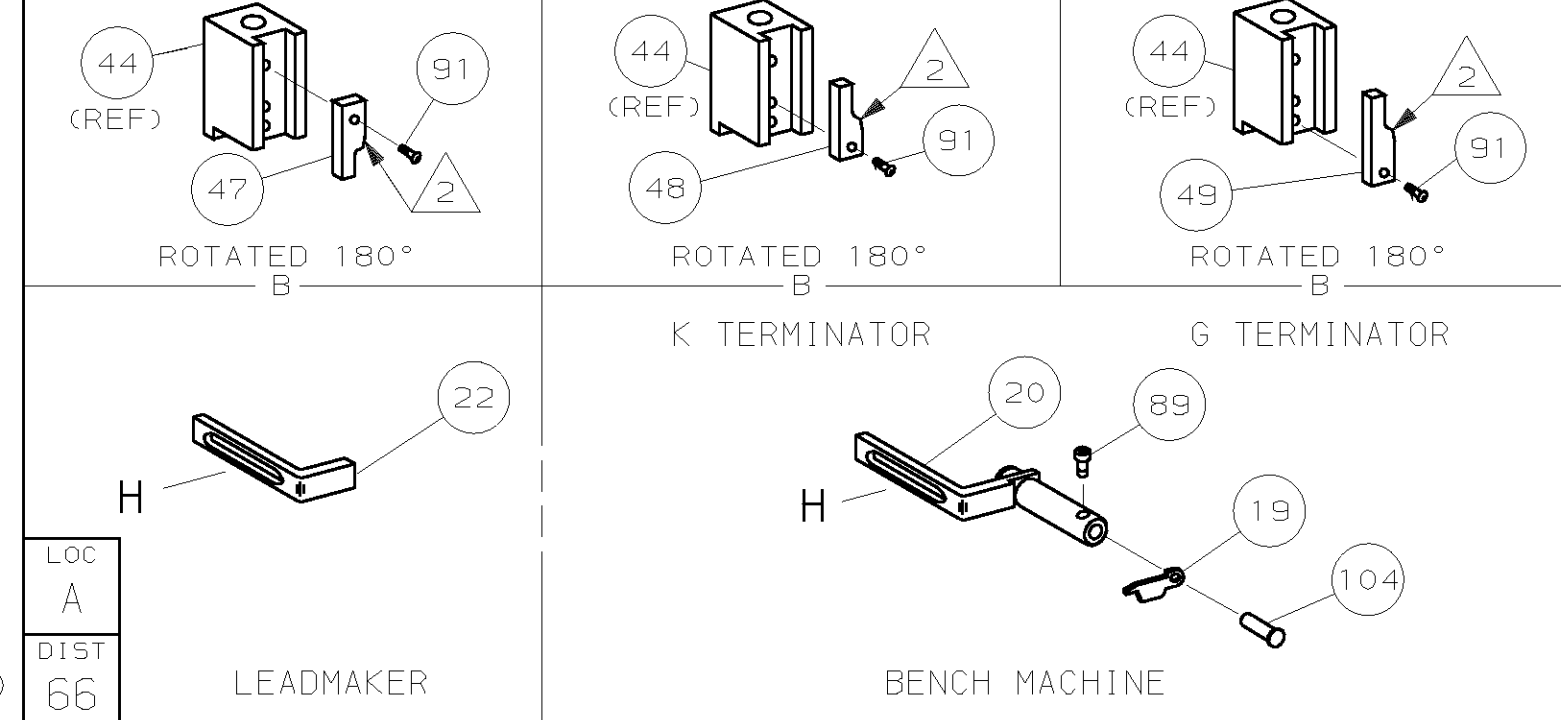

Table with CRIMPING DATA and WIRE STRIP LENGTH. Columns include CRIMP HEIGHT, WIRE SIZE, CRIMP WIRE, and INSUL.

Main Parts List table with columns for QTY, REF, PART NO, DESCRIPTION, and ITEM NO.

Table with columns for LEADMAKER, MECH POST FEED, and detailed part descriptions with revision notes.

- 1 RECOMMENDED SPARE PARTS.
2 GREASE LIGHTLY.
3 GUARD MUST BE IN PLACE WHEN OPERATING APPLICATOR IN A BENCH MACHINE.
4 LUBRICATE DAILY USING NO. 20 MACHINE OIL.
5. ITEMS WITH QTY OF REF SPECIFIED (EXCEPT ITEMS 78 AND 79) ARE USED ON ITEM 46.