

TOLERANCE UNLESS OTHERWISE SPECIFIED	
.X	±0.25
.XX	±0.15
.XXX	±0.10

THIS IS A C.A.D. GENERATED DRAWING
DO NOT MAKE MANUAL REVISIONS TO MASTER.
UNLESS OTHERWISE SPECIFIED, ALL RADIUS ARE 0.2 MM.

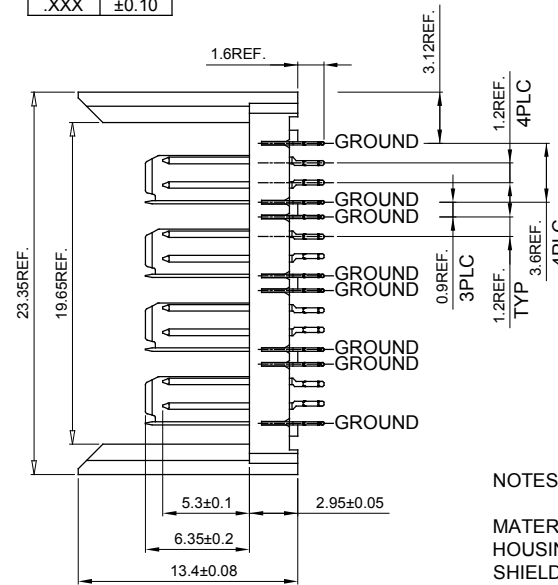
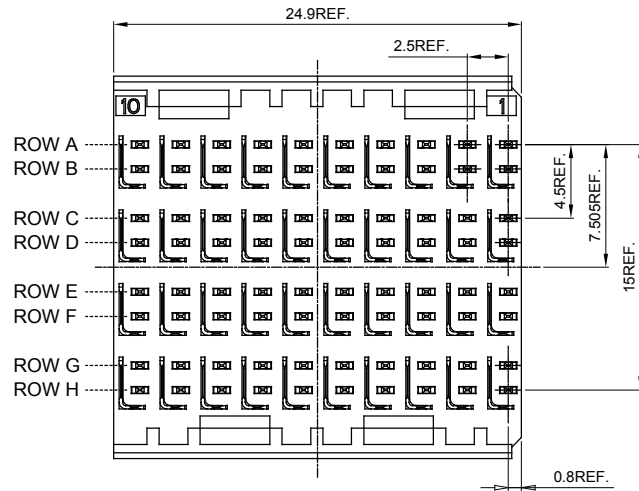
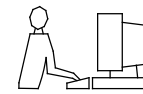

NOTES:

MATERIAL:
HOUSING:
SHIELD:
CONTACT:

LCP +30% GLASS REINFORCED, UL94V-0
PHOSPHOR BRONZE
PHOSPHOR BRONZE
GOLD FLASH PLATING ON CONTACT AREA
MATTE TIN PLATING 30~100µ" ON SOLDER
TAIL OVER NICKEL 50~150µ" UNDER PLATING

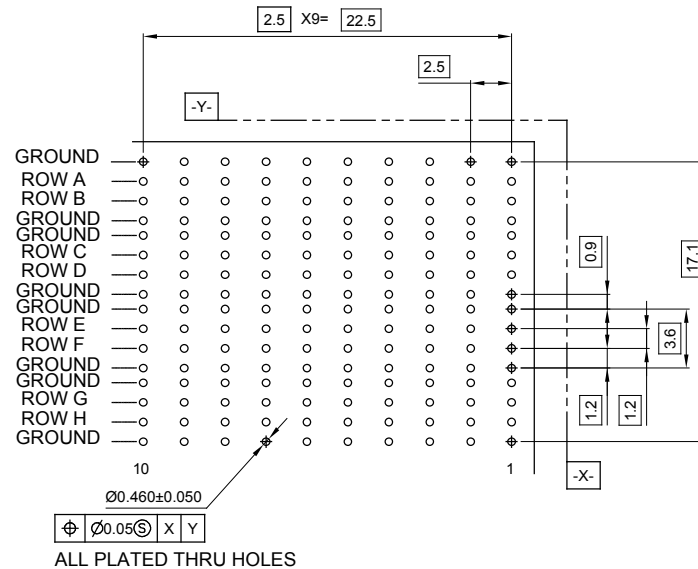
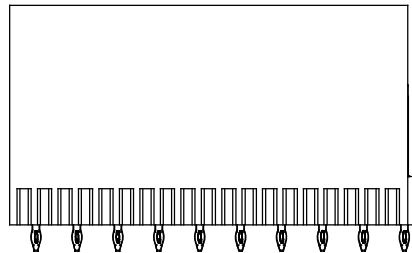

PCB HOLE DIM:
DRILLED HOLE = 0.550±0.020mm
FINISHED HOLE = 0.460±0.050mm
Cu THICKNESS = 0.0375±0.0125mm
Au THICKNESS = 0.007±0.003mm
Ni THICKNESS = 0.0044±0.0032mm
OR Ag THICKNESS = 0.0003±0.002mm

ZD+ CONNECTOR, MALE, VERTICAL, 4 PAIR

ACAD REFERENCE NO.: 500-080-231-H01

DRAWN: W.T

DATE: JUNE.27 /2018

CHECKED:

DATE:

SCALE: N.T.S

SHEET 1 OF 1

DRAWING NUMBER: 500-080-231-H01

ISSUE

PART NUMBER: 500-080-231-H01

1



THIS SERIES FULLY CONFORMS TO
THE EUROPEAN UNION DIRECTIVES
2011/65/EU FOR RoHS COMPLIANCY.



EDAC INC
TORONTO, ONTARIO
CANADA
YOUR CONNECTION TO QUALITY & SERVICE

THESE DRAWINGS AND SPECIFICATIONS
ARE THE PROPERTY OF EDAC INC.,AND
SHALL NOT BE REPRODUCED,OR COPIED
OR USED AS THE BASIS FOR THE
MANUFACTURE OR SALE OF APPARATUS
WITHOUT WRITTEN PERMISSION.