

# Datasheet

## SSD50NBT

*Version 1.15*

---

## REVISION HISTORY

| Version | Date         | Notes   | Approver    |
|---------|--------------|---|-------------|
| 1.0     | 27 Mar 2016  | Initial Version   | Andrew Chen |
| 1.1     | 09 May 2016  | Fixed module size error; updated OS support   | Jay White   |
| 1.2     | 30 June 2016 | Changed document name from HIG to Datasheet<br>Updated current consumption numbers for MIMO; removed Single Stream(SISO) references   | Andrew Chen |
| 1.3     | 07 Sept 2016 | Updated EU Declaration of Conformity<br><br>Updated Tx power numbers to the following:<br><b>802.11a (UNII-1, UNII-2A, UNII-2C) or CH 36 – CH 140</b><br>6 Mbps 18 dBm (63 mW)<br>54 Mbps 15 dBm (32 mW)<br><b>802.11a (UNII-3) or CH 148 – CH 165</b><br>6 Mbps 16 dBm (40 mW)<br>54 Mbps 15 dBm (32 mW)   | Sue White   |
| 1.4     | 03 Nov 2016  | <b>802.11n (5 GHz) (UNII-1, UNII-2A, UNII-2C) or CH 36 – CH 140</b><br>6.5 Mbps (MCS0;HT20) 18 dBm (63 mW)<br>65 Mbps (MCS7;HT20) 14 dBm (25 mW)<br>(MCS0;HT40) 15 dBm (32 mW)<br>(MCS7; HT40) 12 dBm (16 mW)<br><b>802.11n (5 GHz) (UNII-3) or CH 148 – CH 165</b><br>6.5 Mbps (MCS0;HT20) 16 dBm (40 mW)<br>65 Mbps (MCS7;HT20) 13 dBm (20 mW)<br>(MCS0;HT40) 15 dBm (32 mW)<br>(MCS7; HT40) 12 dBm (16 mW) | Andrew Chen |
| 1.5     | 08 Nov 2016  | Updated to add section numbers.   | Sue White   |
| 1.6     | 09 Dec 2014  | Removed <i>Preliminary</i> references   | Jay White   |
| 1.7     | 06 Feb 2017  | Added Packaging section   | Andrew Chen |
| 1.8     | 07 Feb 2017  | Removed duplicate section re: Reflow  | Andrew Chen |
| 1.9     | 10 Mar 2017  | Updated 5 GHz frequency bands and operating channels info.  | Kris Sidle  |
| 1.10    | 03 Apr 2017  | Removed M2US50NBT references  | Andrew Chen |
| 1.11    | 1 May 2017   | OS Support  | Jay White   |
| 1.12    | 15 June 2017 | Updated EU DoC with new RED standards   | Tom Smith   |
| 1.13    | 18 Aug 2017  | Removed 802.11r references  | Jay White   |
| 1.14    | 01 May 2018  | Updated product photo<br>Updated Industry Canada statement<br>Updated to new Laird template   | Maggie Teng |
| 1.15    | 06 Mar 2019  | Updated logos and URLs  | Sue White   |

## CONTENTS

|        |   |    |
|--------|---|----|
| 1      | Scope   | 4  |
| 2      | Introduction  | 4  |
| 3      | SSD50NBT Features Summary                                 | 5  |
| 4      | Specifications  | 6  |
| 5      | WLAN Functional Description                               | 11 |
| 6      | Bluetooth Functional Description                          | 15 |
| 7      | Block Diagram   | 16 |
| 8      | Electrical Characteristics                                | 17 |
| 8.1    | Absolute Maximum Ratings                                  | 17 |
| 8.2    | Recommended Operating Conditions                          | 17 |
| 8.3    | DC Electrical Characteristics                             | 18 |
| 8.4    | WLAN Radio Receiver Characteristics                       | 20 |
| 8.5    | WLAN Transmitter Characteristics                          | 21 |
| 9      | Bluetooth Radio Characteristics                           | 23 |
| 10     | SDIO Timing Requirements                                  | 25 |
| 11     | Pin Definitions   | 26 |
| 11.1   | Integration Considerations                                | 28 |
| 12     | Boot Strap Options for Wi-Fi Interface                    | 29 |
| 13     | Mechanical Specifications                                 | 29 |
| 14     | RF Layout Design Guidelines                               | 31 |
| 15     | Recommended Storage, Handling, Baking, and Reflow Profile | 32 |
| 15.1   | Required Storage Conditions                               | 32 |
| 15.2   | Baking Conditions   | 33 |
| 15.3   | Surface Mount Conditions                                  | 33 |
| 15.3.1 | Soldering   | 33 |
| 15.3.2 | Cautions When Removing the SIP from the Platform for RMA  | 34 |
| 15.3.3 | Precautions for Use                                       | 35 |
| 16     | Packaging Information                                     | 36 |
| 17     | Regulatory  | 38 |
| 17.1   | Certified Antennas  | 38 |
| 18     | FCC and IC Regulatory                                     | 38 |
| 18.1   | FCC   | 39 |
| 18.2   | Industry Canada   | 40 |
| 19     | European Union Regulatory                                 | 42 |
| 20     | Ordering Information                                      | 44 |
| 20.1   | General Comments  | 44 |

# 1 SCOPE

This document describes key hardware aspects of the Laird SSD50NBT system in package (SIP) modules providing SDIO interface for WLAN connection and UART/PCM for Bluetooth® connection. This document is intended to assist device manufacturers and related parties with the integration of this radio into their host devices. Data in this document is drawn from a number of sources and includes information found in the Qualcomm Atheros (QCA) QCA6004 and Cambridge Silicon Radio Ltd. (CSR) CSR8811 A08 data sheets issued in July 2011, along with other documents provided from QCA and CSR.

**Note that the information in this document is subject to change.** Please refer to the [SSD50NBT product page](#) for the most recent documentation.

# 2 INTRODUCTION

## 2.1 General Description

The SSD50NBT SIP module is an integrated, small form factor 2x2 MIMO 802.11 a/b/g/n WLAN plus *Bluetooth* 4.0 dual mode device that is optimized for low-power mobile devices. The integration of all WLAN and *Bluetooth* functionality in a single package supports low cost and simple implementation along with flexibility for platform-specific customization.

This device is pre-calibrated and integrates the complete transmit/receive RF paths including baluns, mobile phone coexistence band pass filter, diplexer, switches, power amplifier, low noise amplifier, and reference crystal oscillator.

The SSD50NBT device supports Bluetooth 2.1 + EDR and Bluetooth 4.0 (Bluetooth Low Energy or BLE). The device's low power consumption radio architecture and proprietary power save technologies allow for extended battery life.

In addition, its dual 802.11 and Bluetooth radio includes full digital MAC and baseband engines that handle all 802.11 CCK/OFDM® 2.4/5GHz, and Bluetooth basic rate and EDR baseband and protocol processing.

Dual embedded low-power CPU cores minimize host loading and maximize flexibility to support customer specific use cases.



The *Bluetooth*® word mark and logos are registered trademarks owned by Bluetooth SIG, Inc. and any use of such marks by Laird is under license. Other trademarks and trade names are those of their respective owners.

### 3 SSD50NBT FEATURES SUMMARY

The Laird SSD50NBT device features are described in [Table 1](#).

**Table 1: SSD50NBT features**

| Feature  | Description   |
|--|---|
| <b>Radio Front End</b>                         | Integrates the complete transmit/receive RF paths including baluns, coexistence band pass filter, diplexer, switches, power amplifier, low noise amplifier, and reference crystal oscillator.   |
| <b>Enhanced WLAN/BT Coexistence Algorithms</b> | <p>Enhanced important use cases including:</p> <ul style="list-style-type: none"> <li>▪ PCM/I2S digital audio interface</li> <li>▪ BT stereo audio (A2DP)</li> <li>▪ BT data transfer profiles (such as OPP and FTP)</li> <li>▪ BT2.1+EDR</li> <li>▪ BT-LE</li> </ul> <p>Flexible radio architecture ensures simple customization for future use cases.</p>   |
| <b>Power Management</b>                        | <p>Uses power-saving techniques including:</p> <ul style="list-style-type: none"> <li>▪ Gating clocks to idle or inactive blocks</li> <li>▪ Fast start and settling circuits to reduce Tx power</li> <li>▪ Active duty cycles</li> <li>▪ CPU frequency scaling</li> </ul>   |
| <b>Pre-Calibration</b>                         | RF system tested and calibrated in production.  |
| <b>Internal Sleep Clock</b>                    | Integrated on-chip low power sleep clock to regulate internal timing.   |
| <b>Multiple Interface Support</b>              | <ul style="list-style-type: none"> <li>▪ SDIO 2.0 (50 MHz, 4-bit and 1-bit) WLAN</li> <li>▪ HS-UART for Bluetooth HCI (compatible with any upper layer Bluetooth stack)</li> </ul>  |
| <b>Advanced 802.11n</b>                        | <ul style="list-style-type: none"> <li>▪ Half Guard Interval and Frame Aggregation for high throughput</li> <li>▪ Space Time Block Coding (STBC) Rx for improved downlink robustness over range</li> <li>▪ Low Density Parity Check (LDPC) for improved uplink and downlink robustness over range</li> </ul>  |
| <b>Reference Frequency</b>                     | <ul style="list-style-type: none"> <li>▪ Incorporates a 26 MHz reference frequency source in package</li> <li>▪ Sleep regulated and gated to enable the internal crystal to be powered down when the device is in sleep mode</li> <li>▪ BT shares the clock from the Wi-Fi chip</li> <li>▪ Wi-Fi cannot be turned off or in reset when running BT</li> </ul>  |
| <b>Advanced WLAN</b>                           | <p>Includes the following advanced WLAN features:</p> <ul style="list-style-type: none"> <li>▪ IEEE 802.11e QoS, Wi-Fi Alliance WMM Power Save, and 802.11n power saving compliance</li> <li>▪ AES, AES-CCMP, TKIP engines for faster data encryption</li> <li>▪ Cisco CCXv4 ASD, WPS support</li> <li>▪ Standard WEP/WPA/WPA2 for personal and enterprise environments support</li> <li>▪ WWR, 802.11d, 802.11h support</li> <li>▪ Wi-Fi Direct (Peer-to-Peer)</li> <li>▪ RTT for indoor positioning</li> <li>▪ Statistics and events for monitoring</li> <li>▪ Self-managed power state handling</li> <li>▪ Self-contained beacon processing</li> <li>▪ Shared authentication</li> <li>▪ Ad-hoc power save</li> <li>▪ Multiple PMK ID support</li> <li>▪ Simulated UAPSD</li> <li>▪ T-Spec support</li> <li>▪ Production flow diagnostics</li> <li>▪ 3-wire scheme for Wi-Fi and BT coexistence.</li> </ul> |

| Feature                       | Description  |
|-------------------------------|--|
| <b>Host Offloading (WLAN)</b> | Integrates extensive hardware signal processing and an embedded on-chip CPU to offload complete 11n MAC/BB/PHY processing to minimize host processor loading and support application specific customization.   |
| <b>Advanced Bluetooth</b>     | <ul style="list-style-type: none"> <li>▪ High-speed UART port (up to 4 Mbps)</li> <li>▪ HFP v1.6 wide-band speech supported on-chip</li> <li>▪ On-chip encoding of SBC and aptX® codecs for A2DP music streaming</li> <li>▪ PCM/I2S digital audio interface</li> <li>▪ Support for IEEE 802.11 coexistence</li> <li>▪ The flexible RAM/ROM based architecture enables custom or future profiles to be easily added.</li> </ul> |

## 4 SPECIFICATIONS

Table 2: Specifications

| Feature   | Description  |
|---|--|
| <b>Physical Interface</b>   | 64-pin LGA package   |
| <b>Wi-Fi Interface</b>  | 1-bit or 4-bit Secure Digital I/O  |
| <b>Bluetooth Interface</b>  | Host Controller Interface (HCI) using High Speed UART  |
| <b>Main Chip</b>  | Wi-Fi: Qualcomm Atheros QCA6004<br>BT: Cambridge Silicon Radio Ltd. (CSR) CSR8811 A08  |
| <b>Input Voltage Requirements</b>   | 3.3 VDC (3.20V min to 3.46V max)   |
| <b>I/O Signaling Voltage</b>  | 3.3 VDC ± 5% or 1.8 VDC ± 5%   |
| Average Current Consumption, VDDIO = 3.3 volts<br>(At maximum transmit power setting)     | <p><b>MIMO</b></p> <p><b>802.11a (with BT in standby) @ 18 dBm 6 Mbps</b><br/>Transmit: 900 mA<br/>Receive: 260 mA<br/>Reset: 0.13 mA</p> <p><b>802.11b (with BT in standby) @ 18 dBm 1 Mbps</b><br/>Transmit: 680 mA<br/>Receive: 250 mA<br/>Reset: 0.13 mA</p> <p><b>802.11g (with BT in standby) @ 18 dBm 6 Mbps</b><br/>Transmit: 710 mA<br/>Receive: 250 mA<br/>Reset: 0.13 mA</p> <p><b>802.11n (2.4 GHz) (with BT in standby) @ 14 dBm MCS7</b><br/>Transmit: 460 mA<br/>Receive: 250mA<br/>Reset: 0.13 mA</p> <p><b>802.11n (5 GHz) (with BT in standby) @ 14 dBm MCS7</b><br/>Transmit: 720 mA<br/>Receive: 260 mA<br/>Reset: 0.13 mA</p> <p><b>Bluetooth (with Wi-Fi in standby)</b></p> |
| <i>Note: Reset refers to the radio are in reset, both Wifi and BT reset are asserted.</i> |  |

| Feature                                | Description  |
|--|--|
|  | Transmit: 85 mA<br>Receive: 70 mA<br>Reset: 0.13 mA  |
| <b>Operating Temperature</b>           | -30° to 85°C (-22° to 185°F)   |
| <b>Operating Humidity</b>              | 10 to 90% (non-condensing)   |
| <b>Storage Temperature</b>             | -40° to 85°C (-40° to 185°F)   |
| <b>Storage Humidity</b>                | 10 to 90% (non-condensing)   |
| <b>Maximum Electrostatic Discharge</b> | Conductive 4KV; Air coupled 8KV  |
| <b>Size</b>                            | 15 mm (length) x 15 mm (width) x 2.5 mm (thickness)  |
| <b>Weight</b>                          | 1.20 g   |
| <b>Mounting</b>                        | Please see the mounting and handling guide.  |
| <b>Wi-Fi Media</b>                     | Direct Sequence-Spread Spectrum (DSSS)<br>Complementary Code Keying (CCK)<br>Orthogonal Frequency Divisional Multiplexing (OFDM)   |
| <b>Bluetooth Media</b>                 | Frequency Hopping Spread Spectrum (FHSS)   |
| <b>Wi-Fi Media Access Protocol</b>     | Carrier sense multiple access with collision avoidance (CSMA/CA)   |
| <b>Network Architecture Types</b>      | Infrastructure and ad-hoc  |
| <b>Wi-Fi Standards</b>                 | IEEE 802.11a, 802.11b, 802.11d, 802.11e, 802.11g, 802.11h, 802.11i, 802.11n  |
| <b>Bluetooth Standards</b>             | <i>Bluetooth</i> version 2.1 with Enhanced Data Rate<br><i>Bluetooth</i> 4.0 (Bluetooth Low Energy or BLE)   |
| <b>Wi-Fi Data Rates Supported</b>      | 11a (OFDM) 6, 9, 12, 18, 24, 36, 48, 54 Mbps<br>802.11b (DSSS, CCK) 1, 2, 5.5, 11 Mbps<br>802.11g (OFDM) 6, 9, 12, 18, 24, 36, 48, 54 Mbps<br>802.11n (OFDM, MCS 0-15)<br>Full Guard Interval: 6.5,13.0, 19.5, 26.0,39.0,52.0,58.5,65.0, 13.0,26.0,39.0, 52.0, 78.0,104.0,117.0 Mbps<br>Short Guard Interval: 1.2,14.4,21.7,29.9,43.3,57.8,65.0,72.2, 14.4,28.9,43.3,57.8, 86.7,115.6,130.0,144.4 Mbps |
| <b>Modulation</b>                      | BPSK @ 1, 6,9, 6.5, 7.2,13 and 14.4 Mbps<br>QPSK @ 2, 12, 18, 13, 14.4,19.5, 21.7, 26, 28.9, 39,43.3 Mbps<br>CCK @ 5.5 and 11 Mbps<br>16-QAM @ 24, 36,26, 29.9,39,43.3,52,57.8,78,86.7 Mbps<br>64-QAM @ 48,54,52, 57.8, 58.5, 65,72.2,104.0,115.6,117.0,130.0,144.4 Mbps   |
| <b>802.11n Spatial Streams</b>         | 2 (2x2 MIMO)   |
| <b>Bluetooth Data Rates Supported</b>  | 1, 2, 3 Mbps   |
| <b>Bluetooth Modulation</b>            | GFSK@ 1 Mbps<br>Pi/4-DQPSK@ 2 Mbps<br>8-DPSK@ 3 Mbps   |



| Feature                                   | Description  |
|---|--|
| <b>Regulatory Domain Support</b>          | FCC (Americas, Parts of Asia, and Middle East)<br>ETSI (Europe, Middle East, Africa, and Parts of Asia)<br>IC (Industry Canada )<br>MIC (Japan) (formerly TELEC) – Option<br>KC (Korea) (formerly KCC) – Option  |
| <b>2.4 GHz Frequency Bands</b>            | <b>ETSI:</b> 2.4 GHz to 2.483 GHz<br><b>FCC:</b> 2.4 GHz to 2.473 GHz<br><b>MIC:</b> 2.4 GHz to 2.495 GHz<br><b>KC:</b> 2.4 GHz to 2.483 GHz   |
| <b>2.4 GHz Operating Channels (Wi-Fi)</b> | <b>ETSI:</b> 13 (3 non-overlapping)<br><b>FCC:</b> 11 (3 non-overlapping)<br><b>MIC:</b> 14 (4 non-overlapping)<br><b>KC:</b> 13 (3 non-overlapping)   |
| <b>5 GHz Frequency Bands</b>              | <b>ETSI</b><br>5.15 GHz to 5.35 GHz (Ch 36/40/44/48/52/56/60/64)<br>5.47 GHz to 5.725 GHz (Ch 100/104/108/112/116/120/124/128/132/136/140)<br><b>FCC</b><br>5.15 GHz to 5.35 GHz (Ch 36/40/44/48/52/56/60/64)<br>5.47 GHz to 5.725 GHz (Ch 100/104/108/112/116/120/124/128/ 132/136/140)<br>5.725 GHz to 5.825 GHz (Ch 149/153/157/161/165)<br><b>MIC (Japan)</b><br>5.15 GHz to 5.35 GHz (Ch 36/40/44/48/52/56/60/64)<br>5.47 GHz to 5.725 GHz (Ch 100/104/108/112/116/120/124/128/ 132/136/140)<br><b>KC</b><br>5.15 GHz to 5.35 GHz (Ch 36/40/44/48/52/56/60/64)<br>5.47 GHz to 5.725 GHz (Ch 100/104/108/112/116/120/124)<br>5.725 GHz to 5.825 GHz (Ch 149/153/157/161) |
| <b>5 GHz Operating Channels (Wi-Fi)</b>   | ETSI: 19 non-overlapping)      MIC: 19 non-overlapping<br>FCC: 24 non-overlapping      KC: 19 non-overlapping  |
| <b>Transmit Power</b>                     | <b>802.11a (UNII-1, UNII-2A, UNII-2C) or CH 36 – CH 140</b><br>6 Mbps      18 dBm (63 mW)<br>54 Mbps      15 dBm (32 mW)<br><b>802.11a (UNII-3) or CH 148 – CH 165</b><br>6 Mbps      16 dBm (40 mW)<br>54 Mbps      15 dBm (32 mW)<br><b>802.11b</b><br>1 Mbps      18 dBm (63 mW)<br>11 Mbps      18 dBm (63 mW)<br><b>802.11g</b><br>6 Mbps      18 dBm (63 mW)<br>54 Mbps      15 dBm (32 mW)<br><b>802.11n (2.4 GHz)</b><br>6.5 Mbps (MCS0)      18 dBm (63 mW)<br>65 Mbps (MCS7)      14 dBm (25 mW)<br><b>802.11n (5 GHz) (UNII-1, UNII-2A, UNII-2C) or CH 36 – CH 140</b><br>6.5 Mbps (MCS0;HT20)      18 dBm (63 mW)<br>65 Mbps (MCS7;HT20)      14 dBm (25 mW)     |

**Note:** Transmit power on each channel varies according to individual country regulations. All values for lowest data rate is nominal, +/-2 dBm. Others are +/-2.5 dBm.

**Note:**  
HT40 – 40 Mhz-wide channels  
HT20 – 20 MHz-wide channels



| Feature                                    | Description  |
|--|--|
|  | (MCS0;HT40) 15 dBm (32 mW)<br>(MCS7; HT40) 12 dBm (16 mW)  |
|  | <b>802.11n (5 GHz) (UNII-3) or CH 148 – CH 165</b>   |
|  | 6.5 Mbps (MCS0;HT20) 16 dBm (40 mW)<br>65 Mbps (MCS7;HT20) 13 dBm (20 mW)<br>(MCS0;HT40) 15 dBm (32 mW)<br>(MCS7; HT40) 12 dBm (16 mW) |
|  | <b>Bluetooth</b>   |
|  | 1 Mbps 6 dBm (4 mW)<br>2 Mbps 6 dBm (4 mW)<br>3 Mbps 3 dBm (2 mW)  |
| <b>Typical Receiver Sensitivity</b>        | <b>802.11a:</b>  |
|  | 6 Mbps -93 dBm   |
| <i>Note: All values nominal, +/-3 dBm.</i> | 54 Mbps -75 dBm (PER <= 10%)   |
|  | <b>802.11b:</b>  |
|  | 1 Mbps -95 dBm   |
|  | 11 Mbps -88 dBm (PER <= 10%)   |
|  | <b>802.11g:</b>  |
|  | 6 Mbps -92 dBm   |
|  | 54 Mbps -75 dBm (PER <= 10%)   |
|  | <b>802.11n (2.4 GHz)</b>   |
|  | MCS0 Mbps -92 dBm  |
|  | MCS7 Mbps -72 dBm  |
|  | <b>802.11n (5 GHz)</b>   |
|  | MCS0 Mbps -93 dBm  |
|  | MCS7 Mbps -72 dBm  |
|  | <b>Bluetooth:</b>  |
|  | 1 Mbps -84 dBm (1DH1)  |
|  | 3 Mbps -76 dBm (3DH5)  |
|  | BLE -87 dBm  |
| <b>Operating Systems Supported</b>         | Linux 2.6.x, 3.x.x, 4.0.x kernel<br>Android 4.1.2 (Jellybean) and forward  |

| Feature  | Description   |          |               |         |          |          |      |          |  |
|--|---|----------|---------------|---------|----------|----------|------|----------|--|
| <b>Security</b>  | <p><b>Standards</b></p> <p>Wireless Equivalent Privacy (WEP)<br/>Wi-Fi Protected Access (WPA)<br/>IEEE 802.11i (WPA2)</p> <p><b>Encryption</b></p> <p>Wireless Equivalent Privacy (WEP, RC4 Algorithm)<br/>Temporal Key Integrity Protocol (TKIP, RC4 Algorithm)<br/>Advanced Encryption Standard (AES, Rijndael Algorithm)<br/>Encryption Key Provisioning<br/>Static (40-bit and 128-bit lengths)<br/>Pre-Shared (PSK)</p> <p><b>Dynamic</b></p> <p>802.1X Extensible Authentication Protocol Types</p> <table border="0"> <tr> <td>EAP-FAST</td> <td>PEAP-MSCHAPv2</td> </tr> <tr> <td>EAP-TLS</td> <td>PEAP-TLS</td> </tr> <tr> <td>EAP-TTLS</td> <td>LEAP</td> </tr> <tr> <td>PEAP-GTC</td> <td></td> </tr> </table> | EAP-FAST | PEAP-MSCHAPv2 | EAP-TLS | PEAP-TLS | EAP-TTLS | LEAP | PEAP-GTC |  |
| EAP-FAST   | PEAP-MSCHAPv2   |          |               |         |          |          |      |          |  |
| EAP-TLS  | PEAP-TLS  |          |               |         |          |          |      |          |  |
| EAP-TTLS   | LEAP  |          |               |         |          |          |      |          |  |
| PEAP-GTC   |   |          |               |         |          |          |      |          |  |
| <b>Compliance</b>  | <p><b>ETSI Regulatory Domain</b></p> <p>EN 300 328 (Wi-Fi®)<br/>EN 300 328 v1.8.1 (BT 2.1)<br/>EN 301 489-1<br/>EN 301 489-17<br/>EN 301 893<br/>EN 60950-1<br/>EU 2002/95/EC (RoHS)</p> <p><b>FCC Regulatory Domain</b></p> <p>FCC 15.247 DTS – 802.11b/g (Wi-Fi) – 2.4 GHz<br/>FCC 15.407 UNII – 802.11a (Wi-Fi) – 5 GHz<br/>FCC 15.247 DSS – BT 2.1</p> <p><b>Industry Canada</b></p> <p>RSS-247 – 802.11a/b/g/n (Wi-Fi) – 2.4 GHz, 5.8 GHz, 5.2 GHz, and 5.4 GHz<br/>RSS-247 – BT 2.1</p>   |          |               |         |          |          |      |          |  |
| <b>Certifications</b>  | <p><b>Wi-Fi Alliance</b></p> <p>802.11a, 802.11b, 802.11g, 802.11n<br/>WPA Enterprise<br/>WPA2 Enterprise</p> <p><b>Cisco Compatible Extensions (Version 4)</b></p> <p><b>Bluetooth® SIG Qualification</b></p> <div style="text-align: right;">    </div>  |          |               |         |          |          |      |          |  |
| <b>Warranty</b>  | <b>Three Year Warranty</b>  |          |               |         |          |          |      |          |  |
| <i>All specifications are subject to change without notice</i> |   |          |               |         |          |          |      |          |  |

## 5 WLAN FUNCTIONAL DESCRIPTION

### 5.1 Overview

The SSD50NBT WLAN block is based on the Qualcomm-Atheros AR6004 802.11a/b/g/n chipset. It is optimized for low power embedded applications and is configured to operate in dual-band, two-stream (2x2 MIMO) mode. Its functionality includes:

- Improved throughput on the link due to frame aggregation, RIFS (reduced inter-frame spacing), and half guard intervals.
- Support for STBC (Space Time Block Codes) and LDPC (Low Density Parity Check) codes.
- Improved 11n performance due to features such as 11n frame aggregation (A-MPDU and A-MSDU) and low-overhead host-assisted buffering (RX A-MSDU and RX A-MPDU). These techniques can improve performance and efficiency of applications involving large bulk data transfers such as file transfers or high-resolution video streaming.

Other functionality are listed in the following table (Table 3).

**Table 3: WLAN functions**

| Feature               | Description  |
|-----------------------|--|
| <b>Reset Control</b>  | <p>WLAN_PWD_L and BT_PWD_L pins must be asserted low to reset Wi-Fi and <i>Bluetooth</i>. After these signals are de-asserted, the radio waits for host communication. Until then, all modules except the host interface are held in reset.</p> <p>Once the host has initiated communication, the radio turns on its crystal and then the PLL. After all clocks are stable and running, the block resets are automatically de-asserted.</p> <p><b>Note:</b> Because it derives its clock from WLAN, the <i>Bluetooth</i> function should be powered down/reset whenever WLAN is reset.</p>   |
| <b>Reset Sequence</b> | <p>After a COLD_RESET event, the SSD50NBT enters the HOST_OFF state and awaits communication from the host. From that point, the typical COLD_RESET sequence is shown below:</p> <ul style="list-style-type: none"> <li>▪ When the host is ready to use the radio, it initiates communication via the SDIO.</li> <li>▪ The radio enters the WAKEUP state and then the ON state. Embedded software configures the radio functions and interfaces. When the radio is ready to receive commands from the host, it sets an internal function ready bit.</li> <li>▪ The host reads the ready bit and sends function commands to the radio.</li> <li>▪ The embedded CPU may continue to be held in reset under some circumstances until its reset is cleared by an external pin or when the host clears a register.</li> </ul> |

| Feature                 | Description  |
|-------------------------|--|
| <b>Power Transition</b> | Integrated power management and control functions and low power operation for maximum battery life across all operational states by: <ul style="list-style-type: none"> <li>▪ Gating clocks for logic when not needed</li> <li>▪ Shutting down unneeded high speed clock sources</li> <li>▪ Reducing voltage levels to specific blocks in some states</li> </ul> |

See Figure 1.

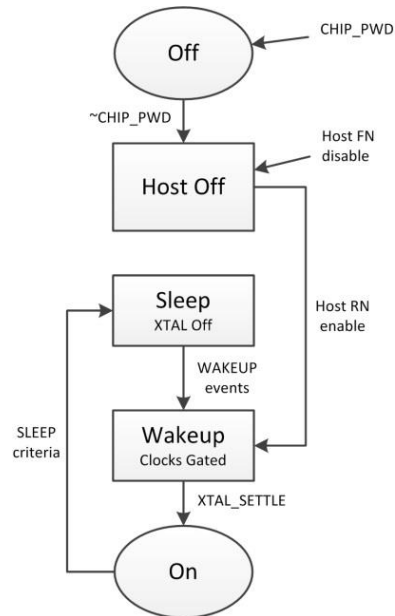

**Figure 1: Power state transition**

| Feature                       | Description   |  |             |            |  |                 |  |              |  |               |   |           |  |
|-------------------------------|---|--|-------------|------------|--|-----------------|--|--------------|--|---------------|---|-----------|--|
| <b>Hardware Power States</b>  | The SSD50NBT hardware has five top-level hardware power states managed by the RTC block.  |  |             |            |  |                 |  |              |  |               |   |           |  |
|                               | <table border="1"> <thead> <tr> <th>State</th> <th>Description</th> </tr> </thead> <tbody> <tr> <td><b>OFF</b></td> <td> <ul style="list-style-type: none"> <li>CHIP_PWD_L pin assertion immediately brings the chip to the OFF state.</li> <li>Sleep clock is disabled.</li> <li>No state is preserved.</li> </ul> </td> </tr> <tr> <td><b>HOST_OFF</b></td> <td> <ul style="list-style-type: none"> <li>WLAN is turned off. The <i>Bluetooth</i> clock is off but should also be powered down through BT_PWD_L.</li> <li>Only the host interface is powered on. The rest of the chip is power gated (off).</li> <li>The host instructs the SSD50NBT to transition to WAKEUP by writing a register in the host interface domain.</li> <li>The embedded CPU and WLAN do not retain state (separate entry).</li> </ul> </td> </tr> <tr> <td><b>SLEEP</b></td> <td> <ul style="list-style-type: none"> <li>Only the sleep clock is operating.</li> <li>The crystal or oscillator is disabled.</li> <li>Any wakeup events force a transition from this state to the WAKEUP state.</li> <li>All internal states are maintained.</li> </ul> </td> </tr> <tr> <td><b>WAKEUP</b></td> <td> <ul style="list-style-type: none"> <li>The system transitions from sleep states to ON.</li> <li>The high frequency clock is gated off as the crystal or oscillator is brought up and the PLL is enabled.</li> <li>WAKEUP duration is programmable.</li> </ul> </td> </tr> <tr> <td><b>ON</b></td> <td> <ul style="list-style-type: none"> <li>The high speed clock is operational and sent to each block enabled by the clock control register.</li> <li>Lower level clock gating is implemented at the block level, including the CPU, which can be gated off using the WAITI instruction while the System is on.</li> <li>No CPU, host, and WLAN activities transition to sleep states. WLAN must be initialized prior to <i>Bluetooth</i> initialization and use.</li> </ul> </td> </tr> </tbody> </table> | State  | Description | <b>OFF</b> | <ul style="list-style-type: none"> <li>CHIP_PWD_L pin assertion immediately brings the chip to the OFF state.</li> <li>Sleep clock is disabled.</li> <li>No state is preserved.</li> </ul> | <b>HOST_OFF</b> | <ul style="list-style-type: none"> <li>WLAN is turned off. The <i>Bluetooth</i> clock is off but should also be powered down through BT_PWD_L.</li> <li>Only the host interface is powered on. The rest of the chip is power gated (off).</li> <li>The host instructs the SSD50NBT to transition to WAKEUP by writing a register in the host interface domain.</li> <li>The embedded CPU and WLAN do not retain state (separate entry).</li> </ul> | <b>SLEEP</b> | <ul style="list-style-type: none"> <li>Only the sleep clock is operating.</li> <li>The crystal or oscillator is disabled.</li> <li>Any wakeup events force a transition from this state to the WAKEUP state.</li> <li>All internal states are maintained.</li> </ul> | <b>WAKEUP</b> | <ul style="list-style-type: none"> <li>The system transitions from sleep states to ON.</li> <li>The high frequency clock is gated off as the crystal or oscillator is brought up and the PLL is enabled.</li> <li>WAKEUP duration is programmable.</li> </ul> | <b>ON</b> | <ul style="list-style-type: none"> <li>The high speed clock is operational and sent to each block enabled by the clock control register.</li> <li>Lower level clock gating is implemented at the block level, including the CPU, which can be gated off using the WAITI instruction while the System is on.</li> <li>No CPU, host, and WLAN activities transition to sleep states. WLAN must be initialized prior to <i>Bluetooth</i> initialization and use.</li> </ul> |
|                               | State   | Description  |             |            |  |                 |  |              |  |               |   |           |  |
|                               | <b>OFF</b>  | <ul style="list-style-type: none"> <li>CHIP_PWD_L pin assertion immediately brings the chip to the OFF state.</li> <li>Sleep clock is disabled.</li> <li>No state is preserved.</li> </ul>   |             |            |  |                 |  |              |  |               |   |           |  |
|                               | <b>HOST_OFF</b>   | <ul style="list-style-type: none"> <li>WLAN is turned off. The <i>Bluetooth</i> clock is off but should also be powered down through BT_PWD_L.</li> <li>Only the host interface is powered on. The rest of the chip is power gated (off).</li> <li>The host instructs the SSD50NBT to transition to WAKEUP by writing a register in the host interface domain.</li> <li>The embedded CPU and WLAN do not retain state (separate entry).</li> </ul> |             |            |  |                 |  |              |  |               |   |           |  |
|                               | <b>SLEEP</b>  | <ul style="list-style-type: none"> <li>Only the sleep clock is operating.</li> <li>The crystal or oscillator is disabled.</li> <li>Any wakeup events force a transition from this state to the WAKEUP state.</li> <li>All internal states are maintained.</li> </ul>   |             |            |  |                 |  |              |  |               |   |           |  |
| <b>WAKEUP</b>                 | <ul style="list-style-type: none"> <li>The system transitions from sleep states to ON.</li> <li>The high frequency clock is gated off as the crystal or oscillator is brought up and the PLL is enabled.</li> <li>WAKEUP duration is programmable.</li> </ul>   |  |             |            |  |                 |  |              |  |               |   |           |  |
| <b>ON</b>                     | <ul style="list-style-type: none"> <li>The high speed clock is operational and sent to each block enabled by the clock control register.</li> <li>Lower level clock gating is implemented at the block level, including the CPU, which can be gated off using the WAITI instruction while the System is on.</li> <li>No CPU, host, and WLAN activities transition to sleep states. WLAN must be initialized prior to <i>Bluetooth</i> initialization and use.</li> </ul>  |  |             |            |  |                 |  |              |  |               |   |           |  |
| <b>Sleep State Management</b> | Sleep state minimizes power consumption while saving system states. In sleep state, all high speed clocks are gated off and the external reference clock source is powered off.   |  |             |            |  |                 |  |              |  |               |   |           |  |
|                               | The system remains in sleep state until a WAKEUP event causes the system to enter WAKEUP state, waits for the reference clock source to stabilize, and then un-gates all enabled clock trees. The embedded CPU wakes up only when an interrupt arrives, which may have also generated the system WAKEUP event.  |  |             |            |  |                 |  |              |  |               |   |           |  |

| Feature                            | Description  |
|------------------------------------|--|
| <b>System Clocking (RTC Block)</b> | <p>The SSD50NBT has an RTC block which controls the clocks and power going to other internal modules. Its inputs consist of sleep requests from these modules and its outputs consists of clock enable and power signals which are used to gate the clocks going to these modules. The RTC block also manages resets going to other modules with the device. The SSD50NBT's clocking is grouped into two types: high-speed and low-speed.</p> <p><b>High Speed Clocking</b></p> <p>The reference 26 MHz clock source inside the SSD50NBT drives the PLL and RF synthesizer of Wi-Fi and <i>Bluetooth</i>. To minimize power consumption, the reference clock source is powered off in SLEEP, HOST_OFF, and OFF states.</p> <p><b>Low Speed Clocking</b></p> <p>On Wi-Fi operation, the SSD50NBT does not need an external sleep clock source. Instead, an internal ring oscillator is used to generate a low frequency sleep clock. It is also used to run the state machines and counters related to low power states. The SSD50NBT has an internal calibration module which produces a 32.768 KHz output with minimal variation. For this, it uses the reference clock source as the golden clock. As a result, the calibration module adjusts for process and temperature variations in the ring oscillator when the system is in ON state.</p> <p>The <i>Bluetooth</i> section shares the clock from the Wi-Fi chip. It is not able to get into deep sleep mode without 32KHz present at pin-24. Without get into deep sleep mode, it consumes 3.3 mA at VDD_BT supply. In order to have the <i>Bluetooth</i> device get into deep sleep mode, a 32.768 KHz slow clock is a must on pin-24. When 32.768 KHz is present on pin-24, the <i>Bluetooth</i> chip can go into deep sleep mode with 0.08 mA current consume on VDD_BT supply.</p> <p><b>Interface Clock</b></p> <p>The host interface clock represents another clock domain for the SSD50NBT. This clock comes from the SDIO and is independent from the other internal clocks. It drives the host interface logic as well as certain registers which can be accessed by the host in HOST_OFF and SLEEP states.</p> |
| <b>MAC/BB/RF Block</b>             | <p>The SSD50NBT Wireless MAC consists of five major blocks:</p> <ul style="list-style-type: none"> <li>▪ Host interface unit (HIU) for bridging to the AHB for bulk data accesses and APB for register accesses</li> <li>▪ Ten queue control units (QCU) for transferring Tx data</li> <li>▪ Ten DCF control units (DCU) for managing channel access</li> <li>▪ Protocol control unit (PCU) for interfacing to baseband</li> <li>▪ DMA receive unit (DRU) for transferring RxX data</li> </ul>   |
| <b>Baseband Block</b>              | <p>The SSD50NBT baseband module (BB) is the physical layer controller for the 802.11b/g/n air interface. It is responsible for modulating data packets in the transmit direction and detecting and demodulating data packets in the receive direction. It has a direct control interface to the radio to enable hardware to dynamically adjust analog gains and modes.</p>   |
| <b>Clock Sharing</b>               | <p>Clock sharing is implemented on the SSD50NBT. The <i>Bluetooth</i> chip (CSR8811) receives a reference clock from the Wi-Fi chip (QCA6004). When Wi-Fi is in power off/reset state, <i>Bluetooth</i> is also off. 32.768KHz slow clock is needed for BT to get into deep sleep mode.</p>  |

## 6 BLUETOOTH FUNCTIONAL DESCRIPTION

The SSD50NBT Bluetooth (BT) block is based on CSR8811A08 and described in the following table (Table 4).

**Table 4: Bluetooth functions**

| Feature                                   | Description  |
|---|--|
| <b>HCI-UART Interface</b>                 | The UART Interface is a standard high-speed UART interface. It operates up to 4 Mbps, supporting <i>Bluetooth</i> HCI UART interface.  |
| <b>PCM or I2S Interface</b>               | <ul style="list-style-type: none"> <li>▪ Continuous PCM encoded audio data transmission and reception over Bluetooth.</li> <li>▪ Processor overhead reduction through hardware support for continual transmission and reception of PCM data.</li> <li>▪ A bidirectional digital audio interface that routes directly into the baseband layer of the firmware. It does not pass through the HCI protocol layer.</li> <li>▪ Hardware on CSR8811 for sending data to and from a SCO connection.</li> <li>▪ Up to three SCO connections on the PCM interface at any one time.</li> <li>▪ PCM interface master, generating PCM_SYNC and PCM_CLK.</li> <li>▪ PCM interface slave, accepting externally generated PCM_SYNC and PCM_CLK.</li> <li>▪ Various clock formats including: <ul style="list-style-type: none"> <li>– *Long Frame Sync</li> <li>– *Short Frame Sync</li> </ul> </li> <li>▪ GCI timing environments</li> <li>▪ 13-bit or 16-bit linear, 8-bit <math>\mu</math>-law or A-law companded sample formats.</li> <li>▪ Receives and transmits on any selection of three of the first four slots following PCM_SYNC.</li> <li>▪ The PCM configuration options are enabled by setting SKEY_PCM_CONFIG32.</li> </ul> |
| <b>CPU and Memory</b>                     | <p>The CSR8811 uses a 16-bit RISC MCU for low power consumption and efficient use of memory. The MCU, interrupt controller, and event timer run the <i>Bluetooth</i> software stack and control the <i>Bluetooth</i> radio and host interfaces.</p> <p>56 KB of on-chip RAM is provided to support the RISC MCU and is shared between the ring buffers used to hold voice/data for each active connection and the general-purpose memory required by the <i>Bluetooth</i> stack.</p> <p>5 Mb of Internal ROM memory is available on the CSR8811. This memory is provided for system firmware, storing CSR8811 settings and program code.</p>   |
| <b>Build-in Standard WLAN Coexistence</b> | The SSD50NBT supports internally the standard WLAN coexistence interface through the WLAN_ACTIVE, BT_PRIORITY, and BT_ACTIVE pins.   |
| <b>Reference Clock</b>                    | <p>The BT block is configured for 26 MHz reference clock frequency. The clock source is provided to BT internally from the WLAN block on demand from BT_CLK_REQ.</p> <p><b>Note:</b> The WLAN block must be initialized prior before BT clock sharing is enabled.</p>  |
| <b>BT Low Energy</b>                      | The SSD50NBT supports Low Energy specification which allows for connection to devices with single mode LE function (such as a watch, sensor, and HID). The implementation is optimized for coexistence with WLAN.  |
| <b>Reset</b>                              | <p>The pin BT_PWD_L resets and powers down the BT block.</p> <p>Holding the BT_PWD_L pin at GND turns off the entire BT block; all state information is lost. To ensure a full reset, the reset signal should be asserted for a period greater than 5 milliseconds.</p>  |

| Feature                | Description  |
|------------------------|--|
| <b>Radio</b>           | The <i>Bluetooth</i> radio shares the single antenna port with the WLAN through an internal 3-way RF switch. The SSD50NBT implements WLAN/BT coexistence internally.<br>VDDIO is to set the I/O voltage internally with either 1.8 V or 3.3 V to ensure same voltage level for the internal Wi-Fi and BT coexistence signal. Refer to the reference design specifications for details. |
| <b>BT wake up Host</b> | PIO-3 is reserved for BT to wake host from deep sleep mode.  |
| <b>SDIO_IOVDD</b>      | WLAN host IO (SDIO) power supply input 1.8V or 3.3V.   |

## 7 BLOCK DIAGRAM

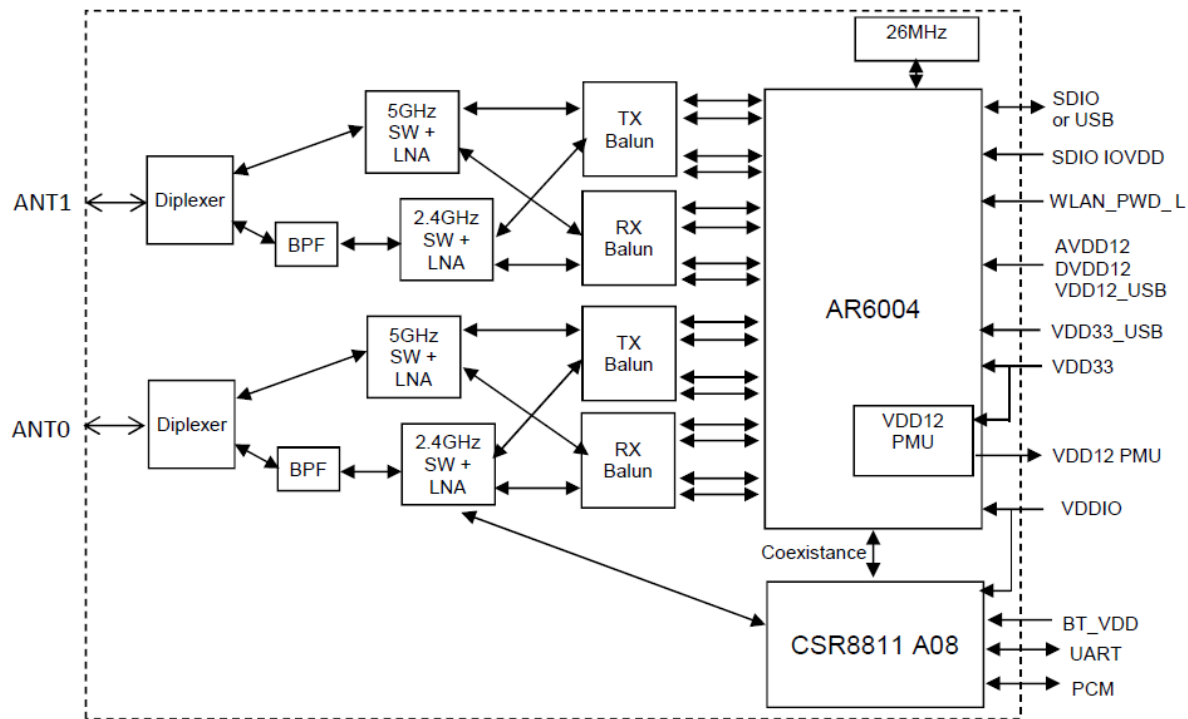

**Note:** Refer to the Specifications table for the Wi-Fi transmitter frequencies.



## 8 ELECTRICAL CHARACTERISTICS

### 8.1 Absolute Maximum Ratings

Table 5 summarizes the absolute maximum ratings and Table 6 lists the recommended operating conditions for the SSD50NBT. Absolute maximum ratings are those values beyond which damage to the device can occur. Functional operation under these conditions, or at any other condition beyond those indicated in the operational sections of this document, is not recommended.

**Note:** Maximum rating for signals follows the supply domain of the signals.

**Table 5: Absolute maximum ratings**

| Symbol (Domain)           | Parameter                                  | Max Rating   | Unit |
|---------------------------|--|--------------|------|
| SDIO_IOVDD                | WLAN host SDIO interface I/O supply        | -0.3 to 4.0  | V    |
| VDDIO (Wi-Fi and BT)      | WLAN and BT I/O configuration power supply | -0.3 to 4.0  | V    |
| VDD33; VDD33_FEM          | External 3.3V power supply                 | -0.3 to 4.0  | V    |
| BT_VDD                    | BT Power core supply                       | 3.6          | V    |
| VDD12_USB, DVDD12, AVDD12 | WLAN 1.2V power supply                     | -0.3 to 1.32 | V    |
| Storage                   | Storage Temperature                        | -40 to +85   | °C   |
| ANT1; ANT2                | Maximum RF input (reference to 50-Ω input) | +10          | dBm  |
| ESD                       | Electrostatic discharge tolerance          | 2000         | V    |

### 8.2 Recommended Operating Conditions

**Table 6: Recommended Operating Conditions**

| Symbol (Domain)           | Parameter                         | Min      | Typ     | Max       | Unit |
|---------------------------|-----------------------------------|----------|---------|-----------|------|
| SDIO_IOVDD                | WLAN host interface I/O supply    | 1.71/3.2 | 1.8/3.3 | 1.89/3.46 | V    |
| VDDIO (Wi-Fi and BT)      | WLAN and BT GPIO I/O power supply | 1.71/3.2 | 1.8/3.3 | 1.89/3.46 | V    |
| VDD33                     | External 3.3V power supply        | 3.2      | 3.30    | 3.46      | V    |
| BT_VDD                    | BT core supply                    | 3.2      | 3.30    | 3.46      | V    |
| VDD12_USB, DVDD12, AVDD12 | WLAN 1.2V power supply            | 1.20     | 1.26    | 1.32      | V    |
| T-ambient                 | Ambient temperature               | -30      | 25      | 85        | °C   |

## 8.3 DC Electrical Characteristics

Table 7 and Table 8 list the general DC electrical characteristics over recommended operating conditions (unless otherwise specified).

**Table 7: General DC electrical characteristics (For 3.3V I/O operation)**

| Symbol | Parameter                 | Conditions                   | Min                               | Typ | Max       | Unit |
|--------|---------------------------|------------------------------|-----------------------------------|-----|-----------|------|
| VIH    | High Level Input Voltage  |                              | 0.7 x VDD                         |     |           | V    |
| VIL    | Low Level Input Voltage   |                              |                                   |     | 0.3 x VDD | V    |
| IIL    | Input Leakage Current     | Without Pull-up or Pull-down | 0V < VIN < VDD<br>0V < VOUT < VDD | 0   | -3        | nA   |
|        |                           | With Pull-up                 | 0V < VIN < VDD<br>0V < VOUT < VDD | 16  | 48        | μA   |
|        |                           | With Pull-down               | 0V < VIN < VDD<br>0V < VOUT < VDD | -14 | -47       | μA   |
| VOH    | High Level Output Voltage | IOH = -4mA                   | 0.9 x VDD                         |     |           | V    |
|        |                           | IOH = -12mA                  | 0.9 x VDD                         |     |           | V    |
| VOL    | Low Level Output Voltage  | IOH = 4mA                    |                                   |     | 0.1 x VDD | V    |
|        |                           | IOH = 12mA                   |                                   |     | 0.1 x VDD | V    |

**Table 8: General DC electrical characteristics (For 1.8V I/O operation)**

| Symbol | Parameter                 | Conditions                   | Min                               | Typ  | Max       | Unit |
|--------|---------------------------|------------------------------|-----------------------------------|------|-----------|------|
| VIH    | High Level Input Voltage  |                              | 0.7 x VDD                         |      |           | V    |
| VIL    | Low Level Input Voltage   |                              |                                   |      | 0.3 x VDD | V    |
| IIL    | Input Leakage Current     | Without Pull-up or Pull-down | 0V < VIN < VDD<br>0V < VOUT < VDD | 0    | -3        | nA   |
|        |                           | With Pull-up                 | 0V < VIN < VDD<br>0V < VOUT < VDD | 3.5  | 13        | μA   |
|        |                           | With Pull-down               | 0V < VIN < VDD<br>0V < VOUT < VDD | -6.2 | -23       | μA   |
| VOH    | High Level Output Voltage | IOH = -4mA                   | 0.9 x VDD                         |      |           | V    |
|        |                           | IOH = -12mA                  | 0.9 x VDD                         |      |           | V    |
| VOL    | Low Level Output Voltage  | IOH = 4mA                    |                                   |      | 0.1 x VDD | V    |
|        |                           | IOH = 12mA                   |                                   |      | 0.1 x VDD | V    |

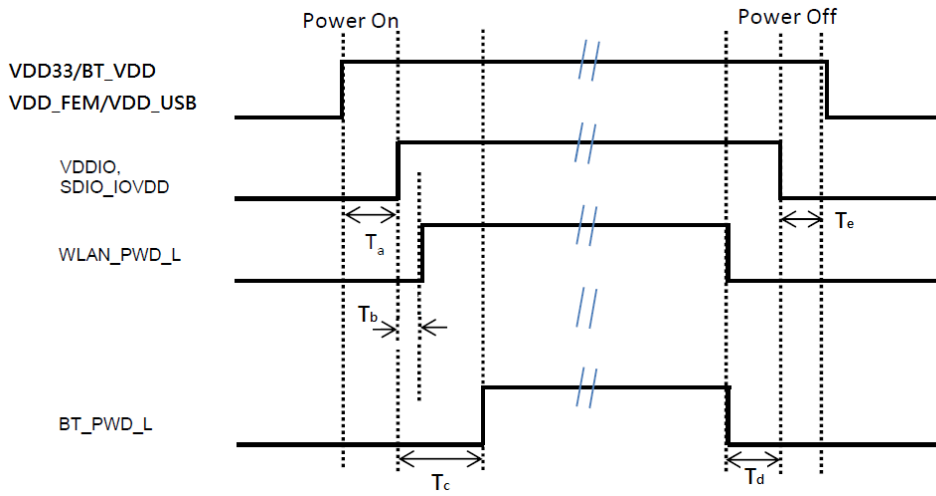

Figure 2: Power On/Off timing

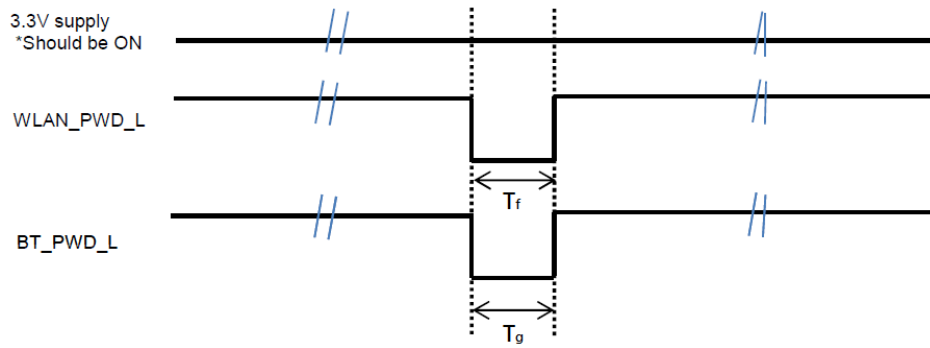

Figure 3: Wi-Fi and BT reset timing

Table 9: Timing Diagram Definitions

| Timing | Description   | Min            | Unit |
|--------|---|----------------|------|
| Ta     | Time between 3.3V (VDD33/BT_VDD/VDD_FEM/VDD_USB) and VDDIO/SDIO_IOVDD supplies  | 0              | µsec |
| Tb     | Time between VDDIO/SDIO_IOVDD supplies valid and WLAN_PWD_L negation.<br><b>Note:</b> There are 10K ohm internal Pull-up on SD_D0, SD_D1 and SD_D3. | 5              | µsec |
| Tc     | Time between VDDIO/SDIO_IOVDD supplies valid and BT_PWD_L negation  | 5              | msec |
| Td     | Time between WLAN_PWD_L assertion and VDDIO/SDIO_IOVDD invalid or time between BT_PWD_L negation and VDDIO/SDIO_IOVDD invalid.                      | 0              | µsec |
| Te     | Time between VDDIO/SDIO_IOVDD invalid and 3.3V (VDD33/BT_VDD/VDD_FEM/VDD_USB) invalid.  | No requirement |      |
| Tf     | Time of WLAN_PWD_L assertion during reset or power down period. Both 3.3V (VDD33/BT_VDD/VDD_FEM/VDD_USB) and VDDIO/SDIO_IOVDD should keep ON.       | 5              | µsec |
| Tg     | Time of BT_PWD_L assertion during reset or power down period. Both 3.3V (VDD33/BT_VDD/VDD_FEM/VDD_USB) and VDDIO/SDIO_IOVDD should keep ON.         | 5              | msec |

**Important:** The SSD50NBT requires SDIO interface lines SD\_CMD, SD\_D1, and SD\_D2 to be high prior to negation of WLAN\_PWD\_L. Designs should drive these lines high or, if necessary, add external pull-ups to insure proper SDIO configuration on WLAN boot-up. Failure to pull these lines high results in non-functional SDIO interface. These are boot-mode strapping options interpreted by the WLAN CPU on power-on. There is 10K ohm pull high resistor already implemented on SD\_D0, SD\_D1, and SD\_D3. No external pull-up is required for those three lines.

We suggest that Tb and Tf timing is greater than 5µsec but no longer than 100 msec.

## 8.4 WLAN Radio Receiver Characteristics

Table 10 and Table 11 summarize the WLAN SSD50NBT receiver characteristics.

Table 10: WLAN receiver characteristics for 2.4 GHz signal chain operation

| Symbol                                   | Parameter                     | Conditions            | Min   | Typ | Max   | Unit |
|--|-------------------------------|-----------------------|-------|-----|-------|------|
| Fr <sub>x</sub>                          | Receive input frequency range |                       | 2.412 |     | 2.484 | GHz  |
| S <sub>r</sub> <sub>f</sub>              | Sensitivity                   |                       |       |     |       | dBm  |
|  | CCK, 1 Mbps                   | See Note <sup>3</sup> |       | -95 |       |      |
|  | CCK, 11 Mbps                  |                       |       | -88 |       |      |
|  | OFDM, 6 Mbps                  |                       |       | -92 |       |      |
|  | OFDM, 54 Mbps                 |                       |       | -75 |       |      |
|  | HT20, MCS0                    |                       |       | -92 |       |      |
|  | HT20, MCS7                    |                       |       | -72 |       |      |
| R <sub>a</sub> <sub>d</sub> <sub>j</sub> | Adjacent channel rejection    |                       |       |     |       |      |
|  | OFDM, 6 Mbps                  | See Note <sup>4</sup> |       | 32  |       |      |
|  | OFDM, 54 Mbps                 |                       |       | 16  |       |      |
|  | HT20, MCS0                    |                       |       | 31  |       |      |

| Symbol | Parameter  | Conditions | Min | Typ | Max | Unit |
|--------|------------|------------|-----|-----|-----|------|
|        | HT20, MCS7 |            |     | 14  |     |      |

<sup>3</sup>Performance data are measured under signal chain operation.

<sup>4</sup>Performance data are measured under signal chain operation.

**Table 11: WLAN Receiver Characteristics for 5 GHz Dual Chain Operation**

| Symbol                                   | Parameter                     | Conditions            | Min  | Typ | Max   | Unit |
|--|-------------------------------|-----------------------|------|-----|-------|------|
| Fr <sub>x</sub>                          | Receive input frequency range |                       | 5.15 |     | 5.825 | GHz  |
| S <sub>r</sub> <sub>f</sub>              | Sensitivity                   |                       |      |     |       | dBm  |
|  | OFDM, 6 Mbps                  |                       |      | -93 |       |      |
|  | OFDM, 54 Mbps                 |                       |      | -75 |       |      |
|  | HT20, MCS0                    | See Note <sup>5</sup> |      | -93 |       |      |
|  | HT20, MCS7                    |                       |      | -72 |       |      |
|  | HT40, MCS0                    |                       |      | -87 |       |      |
| R <sub>a</sub> <sub>d</sub> <sub>j</sub> | Adjacent channel rejection    |                       |      |     |       | dB   |
|  | OFDM, 6 Mbps                  |                       |      | 22  |       |      |
|  | OFDM, 54 Mbps                 | See Note <sup>6</sup> |      | 9   |       |      |
|  | HT20, MCS0                    |                       |      | 20  |       |      |
|  | HT20, MCS7                    |                       |      | 19  |       |      |

<sup>5</sup>Performance data are measured under dual chain operation.

<sup>6</sup>Performance data are measured under dual chain operation.

## 8.5 WLAN Transmitter Characteristics

**Table 12: WLAN transmitter characteristics for 2.4 GHz per chain operation**

| Symbol                                   | Parameter                         | Conditions            | Min   | Typ   | Max   | Unit |
|--|-----------------------------------|-----------------------|-------|-------|-------|------|
| F <sub>t</sub> <sub>x</sub>              | Transmit output frequency range   |                       | 2.412 |       | 2.484 | GHz  |
| P <sub>o</sub> <sub>u</sub> <sub>t</sub> | Output power                      | See Note <sup>7</sup> |       |       |       | dBm  |
|  | 11b mask compliant                | 1Mbps                 |       | 18    |       |      |
|  | 11g mask compliant                | 6Mbps                 |       | 18    |       |      |
|  | 11g EVM compliant                 | 54Mbps                |       | 15    |       |      |
|  | 11n HT20 mask compliant           | MCS0                  |       | 18    |       |      |
|  | 11n HT20 EVM compliant            | MCS7                  |       | 14    |       |      |
|  | 11n HT20 EVM compliant            | MCS15                 |       | 14    |       |      |
| A <sub>T</sub> <sub>x</sub>              | Transmit power accuracy at 18 dBm | -                     | -     | + 2.0 |       | dB   |

| Freq.   | Mode/Rate (Mbps) | Output Power Per Chain (dBm) | Typical Current Consumption Single Chain (mA) <sup>8</sup> | Max. Current Consumption Single Chain (mA) <sup>8</sup> |
|---------|------------------|------------------------------|--|---|
| 2412MHz | 1 Mbps           | 18dBm                        | 420  | 560   |

| Freq.   | Mode/Rate (Mbps) | Output Power Per Chain (dBm) | Typical Current Consumption Single Chain (mA) <sup>8</sup> | Max. Current Consumption Single Chain (mA) <sup>8</sup> |
|---------|------------------|------------------------------|--|---|
| 2442MHz | 54 Mbps          | 15dBm                        | 350  | 450   |
|         | HT20 MCS7        | 14dBm                        | 340  | 420   |
|         | 1 Mbps           | 18dBm                        | 420  | 560   |
|         | 54 Mbps          | 15dBm                        | 350  | 450   |
|         | HT20 MCS7        | 14dBm                        | 340  | 420   |
| 2472MHz | 1 Mbps           | 18dBm                        | 420  | 560   |
|         | 54 Mbps          | 15dBm                        | 350  | 450   |
|         | HT20 MCS7        | 14dBm                        | 340  | 420   |

Table 13: WLAN transmitter characteristics for 5 GHz per chain operation

| Symbol | Parameter                         | Conditions            | Min  | Typ   | Max   | Unit |
|--------|-----------------------------------|-----------------------|------|-------|-------|------|
| Ftx    | Transmit output frequency range   |                       | 5.15 |       | 5.925 | GHz  |
| Pout   | Output power                      | See Note <sup>3</sup> |      |       |       | dBm  |
|        | 11a mask compliant                | 6Mbps                 |      | 18    |       |      |
|        | 11a EVM compliant                 | 54Mbps                |      | 15    |       |      |
|        | 11n HT20 mask compliant           | MCS0                  |      | 18    |       |      |
|        | 11n HT20 EVM compliant            | MCS7                  |      | 14    |       |      |
|        | 11n HT20 EVM compliant            | MCS15                 |      | 14    |       |      |
|        | 11n HT40 mask compliant           | MCS0                  |      | 15    |       |      |
|        | 11n HT40 EVM compliant            | MCS7                  |      | 12    |       |      |
|        | 11n HT40 EVM compliant            | MCS15                 |      | 12    |       |      |
| ATx    | Transmit power accuracy at 18 dBm | -                     | -    | + 2.0 |       | dB   |

| Freq.   | Mode/Rate [Mbps] | Output Power Per Chain [dBm] | Typical Current Consumption Single Chain (mA) <sup>8</sup> | Max. Current Consumption Single Chain (mA) <sup>8</sup> |
|---------|------------------|------------------------------|--|---|
| 5180MHz | 54 Mbps          | 15 dBm                       | 490  | 590   |
|         | HT20 MCS7        | 14 dBm                       | 450  | 560   |
|         | HT40 MCS7        | 12 dBm                       | 470  | 540   |
| 5500MHz | 54 Mbps          | 15 dBm                       | 490  | 590   |
|         | HT20 MCS7        | 14 dBm                       | 450  | 560   |
|         | HT40 MCS7        | 12 dBm                       | 470  | 540   |
| 5825MHz | 54 Mbps          | 15 dBm                       | 490  | 590   |
|         | HT20 MCS7        | 14 dBm                       | 450  | 560   |
|         | HT40 MCS7        | 12 dBm                       | 470  | 540   |

<sup>7</sup>Performance data are measured under single chain operation.

**Note:** Final TX power values on each channels are limited by the regulatory certification test limit.

**Note:** 2.4 GHz does not support HT40 operation, only 5 GHz support HT40 operation.

## 9 BLUETOOTH RADIO CHARACTERISTICS

Table 14 through Table 15 describe the basic rate transmitter performance, enhanced data transmitter performance, basic rate receiver performance, enhanced rate receiver performance, and current consumption conditions at 25°C.

**Table 14: Basic rate transmitter performance temperature at 25°C (3.3V)**

| Test Parameter                           | Min | Typ | Max    | BT Spec.                      | Unit           |
|--|-----|-----|--------|-------------------------------|----------------|
| Maximum RF Output Power                  | 2   | 6   | —      | -6 to +10                     | dBm            |
| Frequency Range                          | 2.4 | —   | 2.4835 | $2.4 \leq f \leq 2.4835$      | GHz            |
| 20 dB Bandwidth                          | —   | 925 | —      | $\leq 1000$                   | KHz            |
| Adjacent Channel TX Power F = F0 + 2 MHz | —   | -36 | —      | $\leq -20$                    | dBm            |
| Adjacent Channel TX Power F = F0 +3 MHz  | —   | -42 | —      | $\leq -40$                    | dBm            |
| $\Delta f_{1avg}$ Maximum Modulation     | 140 | 165 | 175    | $140 < \Delta f_{1avg} < 175$ | KHz            |
| $\Delta f_{2max}$ Minimum Modulation     | —   | 135 | —      | $\geq 115$                    | KHz            |
| $\Delta f_{2avg}/\Delta f_{1avg}$        | —   | 0.9 | —      | $\geq 0.80$                   | —              |
| Initial Carrier Frequency                | —   | 5   | —      | $\leq \pm 75$                 | KHz            |
| Drift Rate                               | —   | 5   | —      | $\leq 20$                     | KHz/50 $\mu$ s |
| Drift (DH1 packet)                       | —   | 6   | —      | $\leq 25$                     | KHz            |
| Drift (DH5 packet)                       | —   | 7   | —      | $\leq 40$                     | KHz            |

**Table 15: Enhanced data rate transmitter performance 25°C (3.3V)**

| Test Parameter                         | Min           | Typ | Max | BT Spec.      | Unit |
|--|---------------|-----|-----|---------------|------|
| Relative Transmit Power                | -1            | 3   | 6   | -4 to +1      | dBm  |
| Max Carrier Frequency Stability  wo    | $\pi/4$ DQPSK | —   | 1   | $\leq \pm 10$ | KHz  |
|  | 8 DPSK        | —   | 1   |               |      |
| Max Carrier Frequency Stability  wi    | $\pi/4$ DQPSK | —   | 1   | $\leq \pm 75$ | KHz  |
|  | 8 DPSK        | —   | 1   |               |      |
| Max Carrier Frequency Stability  w0+wi | $\pi/4$ DQPSK | —   | 2   | $\leq \pm 75$ | KHz  |
|  | 8 DPSK        | —   | 1.5 |               |      |
| RMS DEVM                               | $\pi/4$ DQPSK | —   | 6   | $\leq 20$     | %    |
|  | 8 DPSK        | —   | 6   | $\leq 13$     | %    |
| Peak DEVM                              | $\pi/4$ DQPSK | —   | 16  | $\leq 35$     | %    |
|  | 8 DPSK        | —   | 15  | $\leq 25$     | %    |
| 99% DEVM                               | $\pi/4$ DQPSK | —   | 12  | $\leq 30$     | %    |
|  | 8 DPSK        | —   | 12  | $\leq 20$     | %    |
| EDR Differential Phase Encoding        | —             | 99  | —   | $\geq 99$     | %    |

| Test Parameter         |                          | Min | Typ | Max | BT Spec.   | Unit |
|------------------------|--------------------------|-----|-----|-----|------------|------|
| Adjacent Channel Power | $F \geq \pm 3\text{MHz}$ | —   | -60 | —   | $< -40$    | dBm  |
|                        | $F = \pm 2\text{MHz}$    | —   | -28 | —   | $\leq -20$ | dBm  |
|                        | $F = \pm 1\text{MHz}$    | —   | -32 | —   | $\leq -26$ | dB   |

Table 16: Basic rate receiver performance at 3.3V

| Test Parameter                               |   | Min | Typ     | Max | BT Spec.   | Unit |
|--|---|-----|---------|-----|------------|------|
| Sensitivity                                  | $\text{BER} \leq 0.1\%$                       | —   | -84     | -78 | $\leq -70$ | dBm  |
| Maximum Input                                | $\text{BER} \leq 0.1\%$                       | -20 | -10     | —   | $\geq -20$ | dBm  |
| Carrier-to-Interferer Ratio (C/I)            | Co-Channel                                    | —   | —       | 11  | 11         |      |
|  | Adjacent Channel ( $\pm 1\text{MHz}$ )        | —   | -4/-2   | 0   | 0          | dB   |
|  | Second Adjacent Channel ( $\pm 2\text{MHz}$ ) | —   | -35/-28 | -30 | -30        | dB   |
|  | Third Adjacent Channel ( $\pm 3\text{MHz}$ )  | —   | -42     | -40 | -40        | dB   |
| Maximum Level of Intermodulation Interferers |   | -39 | -30     | -   | $\geq -39$ | dBm  |

Table 17: Enhanced data rate receiver performance 3.3V

| Test Parameter                                  |               | Min | Typ     | Max | Bluetooth Specification | Unit |
|---|---------------|-----|---------|-----|-------------------------|------|
| Sensitivity (BER $\leq 0.01\%$ )                | 8 DPSK        | —   | -76     | -71 | $\leq -70$              | dBm  |
| Maximum Input (BER $\leq 0.1\%$ )               | $\pi/4$ DQPSK | -20 | —       | —   | $\geq -20$              | dBm  |
|   | 8 DPSK        | -20 | —       | —   | $\geq -20$              | dBm  |
| Co-Channel C/I (BER $\leq 0.1\%$ )              | $\pi/4$ DQPSK | —   | 10      | 13  | $\leq \pm 13$           | dB   |
|   | 8 DPSK        | —   | 18      | 20  | $\leq \pm 20$           | dB   |
| Adjacent Channel C/I (BER $\leq 0.1\%$ )        | $\pi/4$ DQPSK | —   | -9/-6   | 0   | $\leq 0$                | dB   |
|   | 8 DPSK        | —   | -3/0    | 5   | $\leq 5$                | dB   |
| Second Adjacent Channel C/I (BER $\leq 0.1\%$ ) | $\pi/4$ DQPSK | —   | -42/-28 | -30 | $\leq -30$              | dB   |
|   | 8 DPSK        | —   | -28/-22 | -25 | $\leq -25$              | dB   |
| Third Adjacent Channel C/I (BER $\leq 0.1\%$ )  | $\pi/4$ DQPSK | —   | -45     | -40 | $\leq -40$              | dB   |
|   | 8 DPSK        | —   | -39     | -33 | $\leq -33$              | dB   |



## 10 SDIO TIMING REQUIREMENTS

The following figure (Figure 4) and table (Table 18) display SDIO default mode timing.

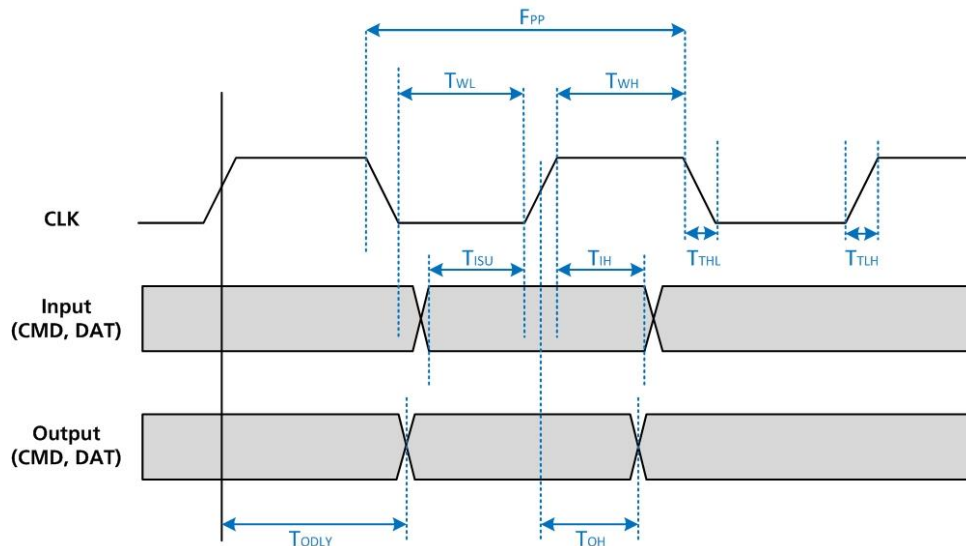

Figure 4: SDIO default mode timing

**Note:** Timing is based on  $CL \leq 40$  pF load on CMD and Data.

Table 18: SDIO timing requirements

| Symbol                                | Parameter                              | Min. | Typ. | Max. | Unit |
|---------------------------------------|--|------|------|------|------|
| fPP                                   | Frequency – Data Transfer mode         | 0    | -    | 50   | MHz  |
| tWL                                   | Clock low time                         | 7    | -    | -    | ns   |
| tWH                                   | Clock high time                        | 7    | -    | -    | ns   |
| tTLH                                  | Clock rise time                        | -    | -    | 10   | ns   |
| tTHL                                  | Clock low time                         | -    | -    | 10   | ns   |
| Inputs: CMD, DAT (referenced to CLK)  |  |      |      |      |      |
| tISU                                  | Input setup time                       | 6    | -    | -    | ns   |
| tIH                                   | Input hold time                        | 2    | -    | -    | ns   |
| Outputs: CMD, DAT (referenced to CLK) |  |      |      |      |      |
| tODLY                                 | Output delay time – Data Transfer mode | 0    | -    | 14   | ns   |

## 11 PIN DEFINITIONS

| Pin # | Name                  | Type    | Voltage Reference | Description   | If Not Used      |
|-------|-----------------------|---------|-------------------|---|------------------|
| 1     | GND                   | -       | -                 | Ground  | GND              |
| 2     | GND                   | -       | -                 | Ground  | GND              |
| 3     | WIFI_RFKILL (GPIO-10) | I, PU   | SDIO_IOVDD        | Reserved for RF disable (RF Kill) feature. Active Low.<br><b>Note:</b> The current does not support it.<br># See Boot strap configuration.  | N/C              |
| 4     | XPABIASS1             | O       | VDDIO             | Control signal for external 5GHz power amplifier Chain 1.   | N/C              |
| 5     | GND                   | -       | -                 | Ground  | GND              |
| 6     | VDD33_FEM             | Power   | -                 | 3.3V Power for FEM  | 3.3V             |
| 7     | VDD33_FEM             | Power   | -                 | 3.3V Power for FEM  | 3.3V             |
| 8     | GND                   | -       | -                 | Ground  | GND              |
| 9     | GND                   | -       | -                 | Ground  | GND              |
| 10    | GND                   | -       | -                 | Ground  | GND              |
| 11    | ANT_1 (Wi-Fi)         | A_IO    | -                 | WLAN antenna port (Chain 1)   | 50 $\Omega$ load |
| 12    | GND                   | -       | -                 | Ground  | GND              |
| 13    | XPABIASS20            | O       | VDDIO             | Control signal for external 2GHz power amplifier Chain 0.   | N/C              |
| 14    | BT_PCM_SYNC           | I/O, PD | VDDIO             | PCM interface synchronization control, input for slave, output for master, weak internal pull-down. High on reset, low after reset.   | N/C              |
| 15    | BT_PCM_BCLK           | I/O, PD | VDDIO             | PCM interface bit clock, input for slave, output for master, weak internal pull-down. High on reset, low after reset.   | N/C              |
| 16    | BT_PCM_IN             | I, PD   | VDDIO             | PCM synchronous input, weak internal pull-down.   | N/C              |
| 17    | BT_PCM_OUT            | O, PD   | VDDIO             | PCM synchronous output, weak internal pull-down.  | N/C              |
| 18    | XPABIASS50            | O       | VDDIO             | Control signal for external 5GHz power amplifier Chain 1.   | N/C              |
| 19    | GND                   | -       | -                 | Ground  | GND              |
| 20    | ANT_0 (Wi-Fi and BT)  | A_IO    | -                 | WLAN/BT antenna port (Chain 0)  | 50 $\Omega$ load |
| 21    | GND                   | -       | -                 | Ground  | GND              |
| 22    | BT_PWD_L              | I, PD   | VDDIO             | BT chip power-down control. Driving this pin active low to power down or to reset the BT chip. Has internal strong pull-down.<br><b>Note:</b> Should be low for at least 5 ms for chip reset. | 10K PU           |
| 23    | NC                    | -       | -                 |   | N/C              |

| Pin # | Name           | Type  | Voltage Reference | Description   | If Not Used        |
|-------|----------------|-------|-------------------|---|--------------------|
| 24    | CLK_32K        | I     | VDDIO             | External 32.768KHz input for BT chip.<br>It is must for BT chip to get deep sleep mode.   | Must be used       |
| 25    | BT_VDD         | Power | -                 | BT core power supply input 3.3V   | 3.3V               |
| 26    | GND            | -     | -                 | Ground  | GND                |
| 27    | BT_UART_RXD    | I, PU | VDDIO             | Bluetooth UART Serial Input   | N/C                |
| 28    | BT_UART_TXD    | O, PU | VDDIO             | Bluetooth UART Serial Output  | N/C                |
| 29    | BT_UART_CTS    | I, PU | VDDIO             | Clear-to-send signal for the Bluetooth UART interface, active low.  | N/C                |
| 30    | BT_UART_RTS    | O, PU | VDDIO             | Request-to-send signal for the Bluetooth UART interface, active low.  | N/C                |
| 31    | BT_WAKEUP_HOST | O     | VDDIO             | When BT wakes up from its deep sleep state, it sends an H pulse signal out to Host. Normally, it is Low state.<br><b>Note:</b> The current software does not support it.  | N/C                |
| 32    | GND            | -     | -                 | Ground  | GND                |
| 33    | VDDIO          | Power | -                 | 1.8 or 3.3V I/O power configuration.<br>This is the reference voltage for all I/O signalling pins; it accepts 1.8V or 3.3V from the host.                                 | 1.8V<br>or<br>3.3V |
| 34    | GND            | -     | -                 | Ground  | GND                |
| 35    | SDIO_CLK       | I     | VDDIO             | SDIO Clock  | N/C                |
| 36    | GND            | -     | -                 | Ground  | GND                |
| 37    | SDIO_DATA_0    | I/O   | SDIO_IOVDD        | SDIO Data 0, internal 10K pulled-up.  | N/C                |
| 38    | SDIO_DATA_1    | I/O   | SDIO_IOVDD        | SDIO Data 1, internal 10K pulled-up.  | N/C                |
| 39    | SDIO_DATA_2    | I/O   | SDIO_IOVDD        | SDIO Data 2.<br><b># See Boot strap configuration.</b>  |                    |
| 40    | SDIO_DATA_3    | I/O   | SDIO_IOVDD        | SDIO Data 3, internal 10K pulled-up.  | N/C                |
| 41    | SD_CMD         | I/O   | SDIO_IOVDD        | SDIO Command signal,<br><b># See Boot strap configuration.</b>  |                    |
| 42    | SDIO_IOVDD     | Power | -                 | WLAN Host bust SDIO I/O power configuration either 1.8V or 3.3V   | 1.8V<br>or<br>3.3V |
| 43    | AVDD_12        | Power | -                 | WLAN internal analogy 1.2V input fed from switching regulator or external 1.2V DC supply  | 1.2V               |
| 44    | DVDD_12        | Power | -                 | WLAN internal analogy 1.2V input fed from switching regulator or external 1.2V DC supply  | 1.2V               |
| 45    | VDD12_USB      | Power | -                 | USB interface 1.2V input fed from switching regulator or external 1.2V DC supply.<br><b>Note:</b> When Wi-Fi run at USB interface, external 1.2V (400mA max) is required. | 1.2V               |

| Pin # | Name           | Type         | Voltage Reference | Description  | If Not Used |
|-------|----------------|--------------|-------------------|--|-------------|
| 46    | VDD33_USB      | Power        | -                 | USB interface 3.3V input.<br>Connect to 3.3V   | 3.3V        |
| 47    | VDD12_PMU      | Power output | -                 | On-Chip 1.2V switching regulator output.<br>A 10uF 6.3V LOW ESR cap is must to connect to this pin as close as possible.   | 10uF        |
| 48    | Reserved       | I/O          | -                 | Reserved pin. Please leave open.   | N/C         |
| 49    | Reserved       | I/O          | -                 | Reserved pin. Please leave open.   | N/C         |
| 50    | GND            | -            | -                 | Ground   | GND         |
| 51    | WLAN_PWD_L     | I, PD        | SDIO_IOVDD        | WLAN Power down, active low, external 10K pull up is required.<br>(0= power down, 1=WLAN awake)<br>Negation samples boot strap pin for SDIO interface mode                       | 10K, PU     |
| 52    | WLAN_TDO       | -            | SDIO_IOVDD        | Pull High for SDIO<br><b># See Boot strap configuration.</b>   |             |
| 53    | AR6004_GPIO38  | I/O          | VDDIO             | Reserved for LTE coexistence;<br>Reserved for WiFi LED indicator, Active High.<br>(Not support Now)  | N/C         |
| 54    | LTE_COEX3      | -            | VDDIO             | Reserved for LTE coexistence   | N/C         |
| 55    | LTE_ACTIVE     | -            | VDDIO -           | Reserved for LTE coexistence   | N/C         |
| 56    | LTE_FRAME_SYNC | -            | VDDIO -           | Reserved for LTE coexistence   | N/C         |
| 57    | VDD33          | Power        | -                 | 3.3V Power   | 3.3V        |
| 58    | VDD33          | Power        | -                 | 3.3V Power   | 3.3V        |
| 59    | GND            | -            | -                 | Ground   | GND         |
| 60    | WAKE_ON_WLAN   | O, PD        | SDIO_IOVDD        | Reserved for Wake-ON-Wireless (WOW) LAN, WLAN output signal to wake up host, active Low and need external 10K pull up.<br><b>Note:</b> The current software does not support it. | 10K,PU      |
| 61    | DEBUG_UART_TXD | O            | SDIO_IOVDD        | WLAN debugging UART TXD (GPIO_11)<br><b># See Boot strap configuration.</b>  | N/C         |
| 62    | WCN_PRIORITY   | -            | -                 | Reserved for LTE coexistence   | N/C         |
| 63    | GND            | -            | -                 | Ground   | GND         |
| 64    | XPABIAS21      | O            | VDDIO             | Control signal for external 2GHz power amplifier Chain 1.  | N/C         |
| 65-80 | GND            | -            | -                 | Thermal Ground Pad<br><b>(Important for RF performance and thermal dissipation; please flow the reference design)</b>  | GND         |

## 11.1 Integration Considerations

The following Wi-Fi information should be taken into consideration when integrating the SSD50NBT:

- When WLAN is communicating via the **SDIO** bus, the internal switch regulator (1.2V out) can be used to power the SSD50NBT itself. **Pin-47** (VDD12\_PMU) of the SSD50NBT is the internal PMU output pin that generates 1.2V to provide to AVDD12 (**pin-43**), DVDD12 (**pin-44**), and AVDD12\_USB (**pin-45**).
- When WLAN is communicating via the **USB** bus, an external 1.2 V (maximum rating 400 mA) is needed for to AVDD12 (**pin-43**), DVDD12 (**pin-44**), and AVDD12\_USB (**pin-45**). This is due to insufficient power from internal PMU.
- No matter if WLAN is running at SDIO or USB bus, a 10uF, 6.3V low ESR capacitor is always needed directly on **pin-47** (VDD12\_PMU) as close as possible to the pin.

## 12 BOOT STRAP OPTIONS FOR WI-FI INTERFACE

SSD50NBT provides SDIO interface for WLAN connection. It is configured per the following table (Table 19).

Table 19: Wi-Fi interface configuration table

| Pin No. | Pin Name       | SDIO 2.0 | Note   |
|---------|----------------|----------|--|
| 41      | SD_CMD         | H        | -  |
| 39      | SDIO_DATA_2    | H        | -  |
| 38      | SDIO_DATA_1    | H        | 10KΩ Pull High to Avoid Booting into test mode.<br><b>Note:</b> It is implemented inside the SSD50NBT. No external pull “H” is needed. |
| 3       | GPIO_10        | L        | 10K Ω Pull “L” to Avoid leakage.   |
| 61      | DEBUG_UART_TXD | N/C      | No connection at SDIO bus.   |
| 52      | WLAN_TDO       | H        | 10K Ω Pull “H” to Avoid leakage. Only SDIO   |

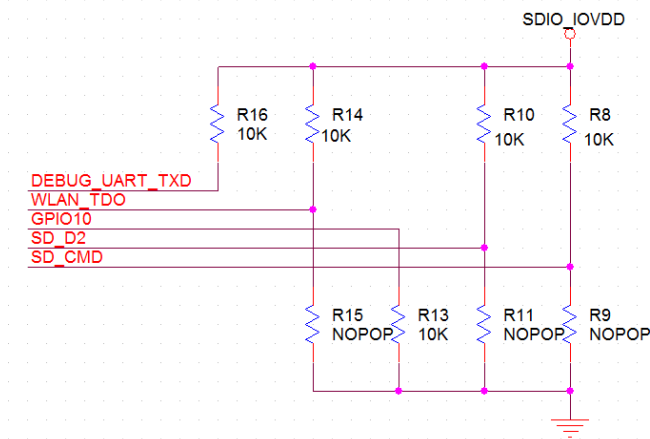

Figure 5: Setting when using SDIO interface

## 13 MECHANICAL SPECIFICATIONS

Module dimensions of SSD50NBT are 15 x 15 x 2.5 mm. Detail drawings are shown in Figure 6.

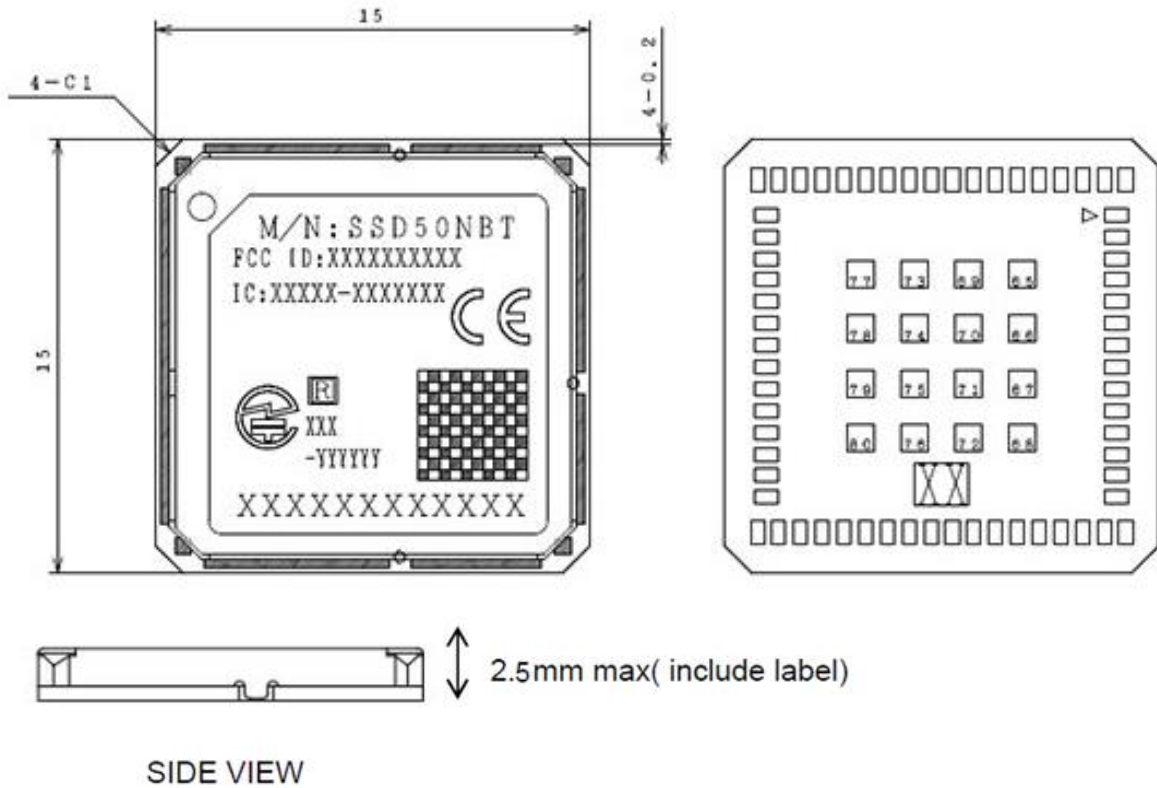

Figure 6: Module dimension of SSD50NBT

**Note:** The Wi-Fi MAC address is located on the product label. The BT MAC address is always numerically subsequent to the Wi-Fi MAC address. Therefore, the BT MAC address is the Wi-Fi MAC address plus one.

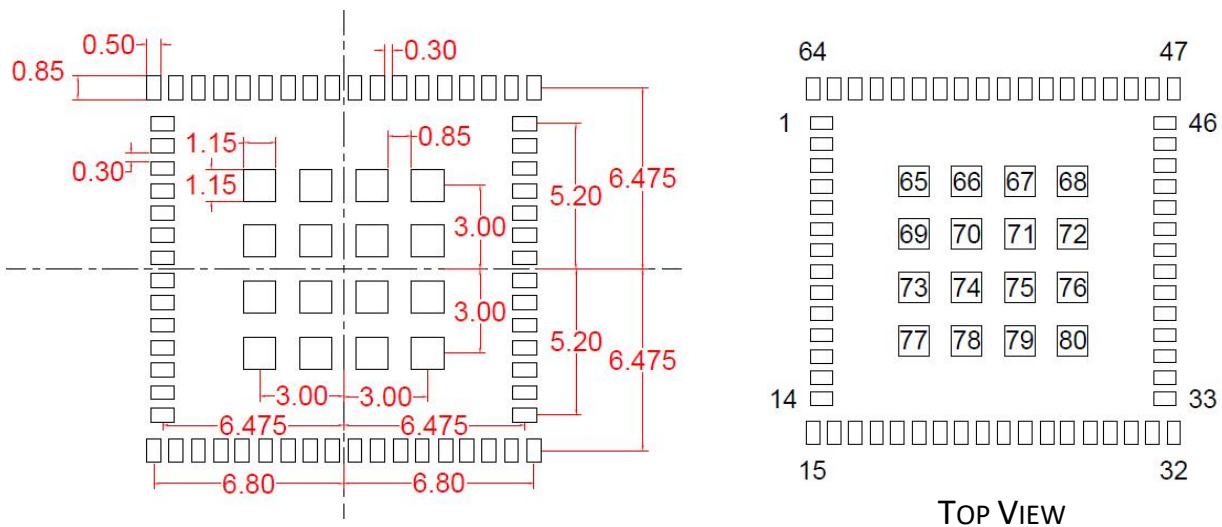
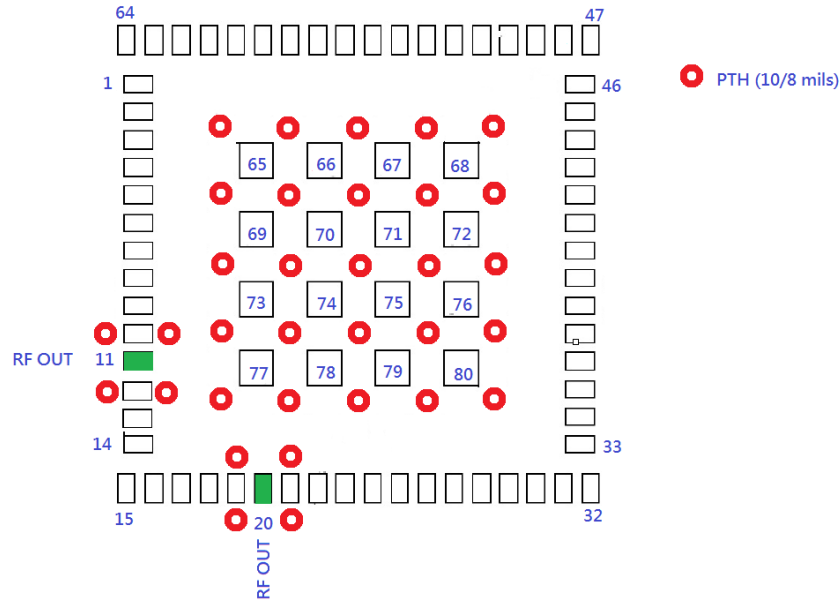

Figure 7: Pad dimensions and pin numbers



Recommend minimal via size and placement for grounding and thermal dissipation. Please double the ground via number when using laser via on HID process. More ground via and the use of 1-oz copper is recommended in our design to get better thermal dissipation.

**Note:** When soldering, the stencil thickness should be  $\geq 0.1$  mm.

## 14 RF LAYOUT DESIGN GUIDELINES

The following is a list of RF layout design guidelines and recommendation when installing a Laird radio into your device.

- Do not run antenna cables directly above or directly below the radio.
- Do not place any parts or run any high speed digital lines below the radio.
- If there are other radios or transmitters located on the device (such as a *Bluetooth* radio), place the devices as far apart from each other as possible. Also, make sure there is at least 25 dB isolation between the Bluetooth antenna and the Wi-Fi antenna.
- Ensure that there is the maximum allowable spacing separating the antenna connectors on the Laird radio from the antenna. In addition, do not place antennas directly above or directly below the radio.
- Laird recommends the use of a double-shielded cable for the connection between the radio and the antenna elements.
- Be sure to put the capacitor on the power pin as close as possible to reduce the radiation issue.
- Use proper electro-static-discharge (ESD) procedures when installing the Laird radio module.
- In order to get maximum throughput when operate at MIMO 2x2, two antennas with at least 25 dB isolation is recommended.
- To avoid negatively impacting Tx power and receiver sensitivity, do not cover the antennas with metallic objects or components.

## 15 RECOMMENDED STORAGE, HANDLING, BAKING, AND REFLOW PROFILE

### 15.1 Required Storage Conditions

#### 15.1.1 Prior to Opening the Dry Packing

The following are required storage conditions **prior to opening the dry packing**:

- Normal temperature: 5~40°C
- Normal humidity: 80% (Relative humidity) or less
- Storage period: One year or less

**Note:** Humidity means Relative Humidity.

#### 15.1.2 After Opening the Dry Packing

The following are required storage conditions **after opening the dry packing** (to prevent moisture absorption):

- Storage conditions for one-time soldering:
  - Temperature: 5~25°C
  - Humidity: 60% or less
  - Period: 48 hours or less after opening
- Storage conditions for two-time soldering

Storage conditions following opening and prior to performing the 1<sup>st</sup> reflow:

- Temperature: 5~25°C
- Humidity: 60% or less
- Period: 48 hours or less after opening

Storage conditions following completion of the 1<sup>st</sup> reflow and prior to performing the 2<sup>nd</sup> reflow

- Temperature: 5~25°C
- Humidity: 60% or less
- Period: 48 hours or less after completion of the 1<sup>st</sup> reflow

#### 15.1.3 Temporary Storage Requirements after Opening

The following are temporary storage requirements after opening:

- Only re-store the devices *once* prior to soldering.
- Use a dry box or place desiccant (with a blue humidity indicator) with the devices and perform dry packing again using heat-sealing.

The following indicate the required storage period, temperature, and humidity for this temporary storage:

Storage temperature and humidity

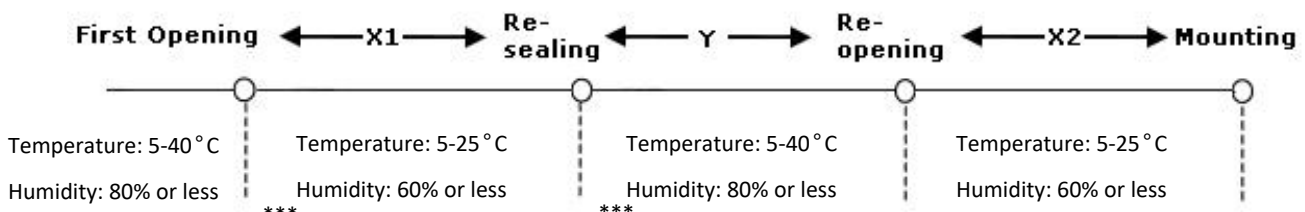



\*\*\* - External atmosphere temperature and humidity of the dry packing

Storage period

- X1+X2 – Refer to [After Opening the Dry Packing](#) storage requirements.
- Y – Two weeks or less.

## 15.2 Baking Conditions

Baking conditions and processes for the SSD50NBT follow the J-STD-033 standard which includes the following:

- The calculated shelf life in a sealed bag is 12 months at <40°C and <90% relative humidity.
- Once the packaging is opened, the SiP must be mounted (according to MSL3/Moisture Sensitivity Level 3) within 168 hours at <30°C and <60% relative humidity.
- If the SiP is not mounted within 168 hours or if, when the packaging is opened, the humidity indicator card displays >10% humidity, then the product must be baked for 48 hours at 125°C (±5°C).

## 15.3 Surface Mount Conditions

The following soldering conditions are recommended to ensure device quality.

### 15.3.1 Soldering

**Note:** When soldering, the stencil thickness should be ≥ 0.1 mm.

Convection reflow or IR/Convection reflow (one-time soldering or two-time soldering in air or nitrogen environment)

- Measuring point – IC package surface
- Temperature profile:

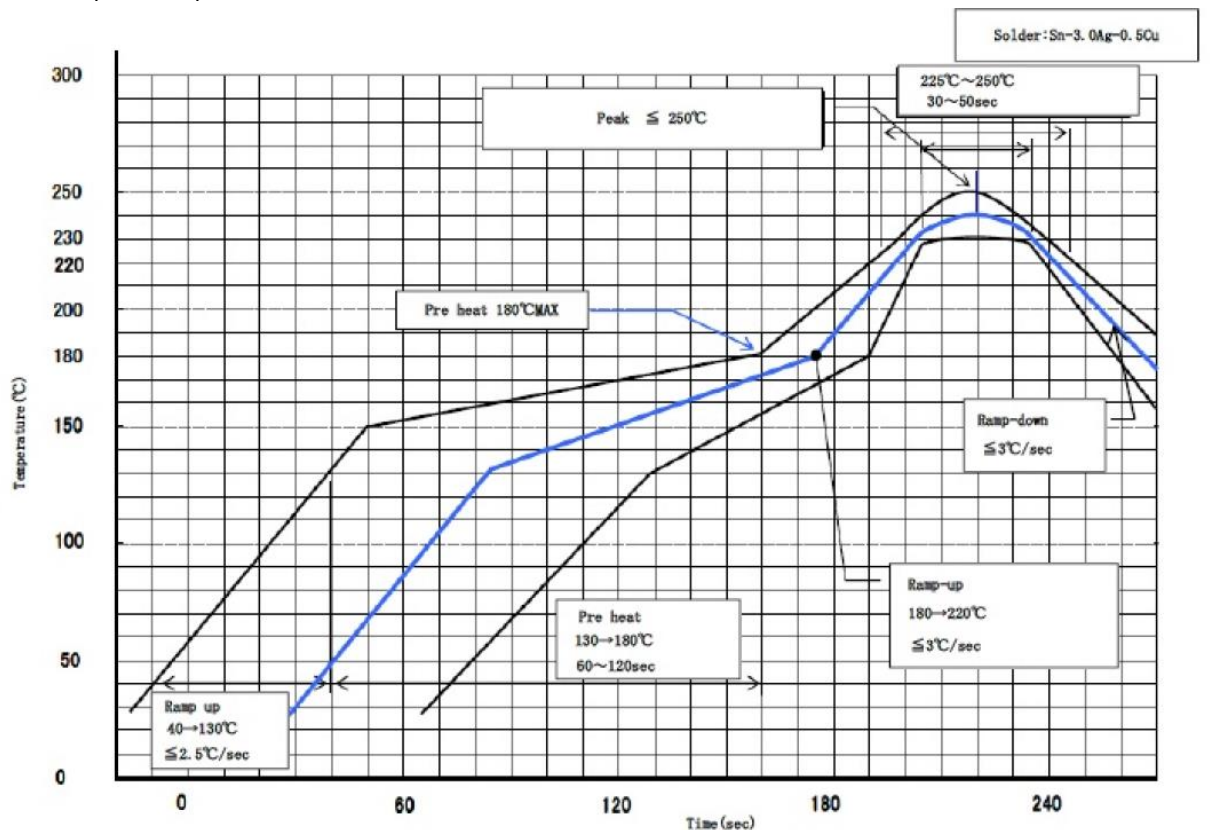

- Ramp-up : 40 - 130 deg. Less than 2.5 deg./sec
- Pre heat : 130 - 180 deg. 60 - 120 sec , 180 deg. MAX
- Ramp-up : 180 - 220 deg. Less than 3 deg./sec
- Peak Temperature : MAX 250 deg.  
225 deg. ~ 250 deg. , 30 ~ 50 sec
- Ramp-down : Less than 3 deg./sec

Figure 8: Temperature profile

### 15.3.2 Cautions When Removing the SIP from the Platform for RMA

- Bake the platform before removing the SIP from the platform. Reference baking conditions.
- Remove the SIP by using a hot air gun. This process should be carried out by a skilled technician.

Suggestion conditions:

- One-side component platform:
  - Set the hot plate at 280°C.
  - Put the platform on the hot plate for 8-10 seconds.
  - Remove the SIP from platform.



Two-side components platform:

- Use two hot air guns
- On the bottom side, use a pre-heated nozzle (temperature setting of 200~250°C) at a suitable distance from the platform PCB.
- On the top side, apply a remove nozzle (temperature setting of 330°C). Heat the SIP until it can be removed from platform PCB.

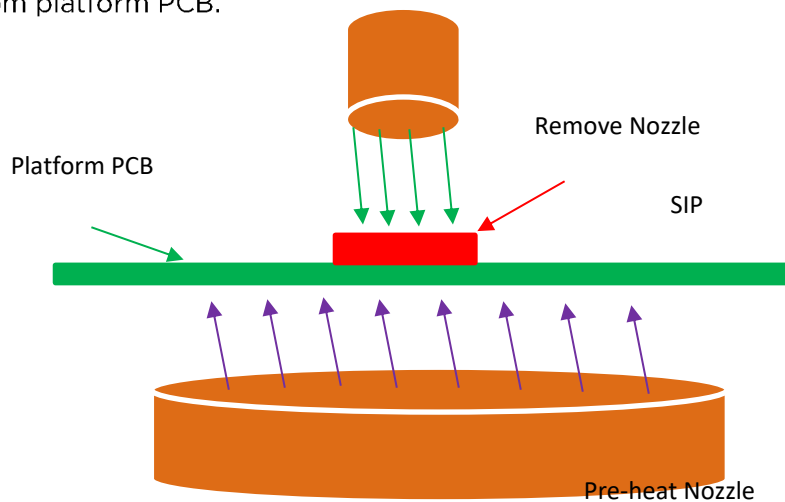

Remove the residue solder under the bottom side of SIP.

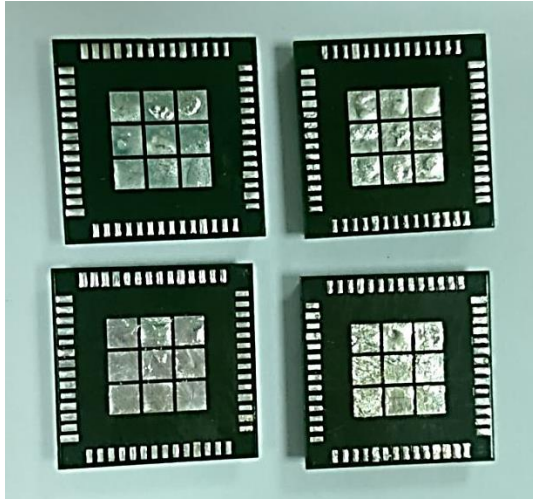

(Not accepted for RMA)

*SIP with residue solder on the bottom*

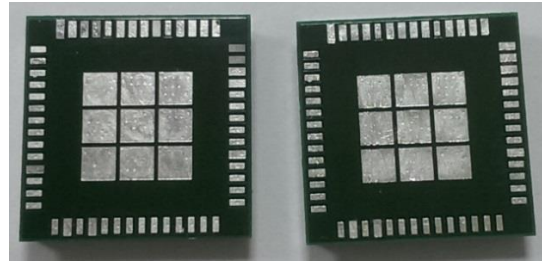

(Accepted for RMA analysis)

*SIP without residue solder on the bottom*

Remove and clean the residue flux if needed.

### 15.3.3 Precautions for Use

- Opening/handling/removing must be done on an anti-ESD treated workbench. All workers must also have undergone anti-ESD treatment.
- The devices should be mounted within one year of the date of delivery.

## 16 PACKAGING INFORMATION

### 16.1 Inner Carton

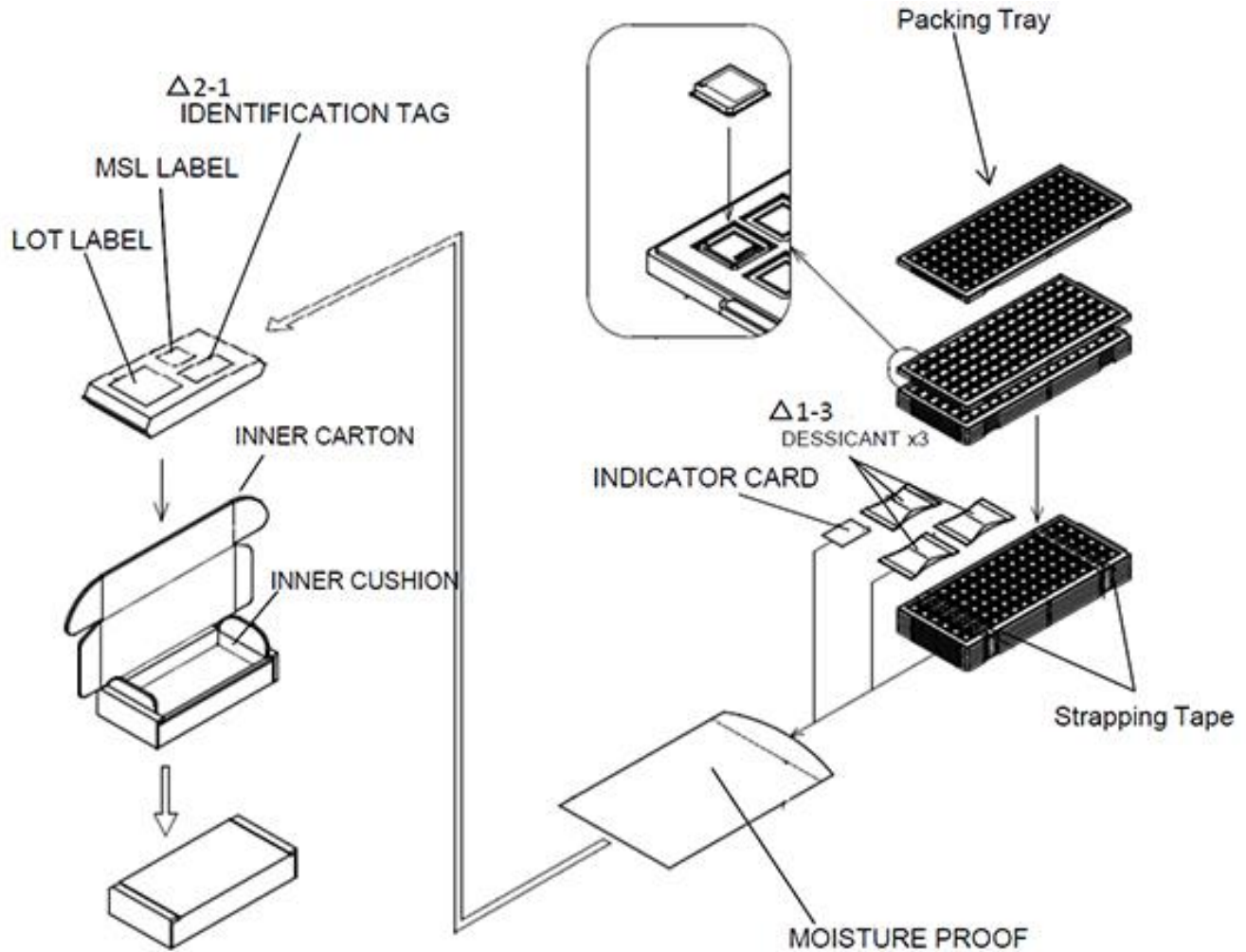
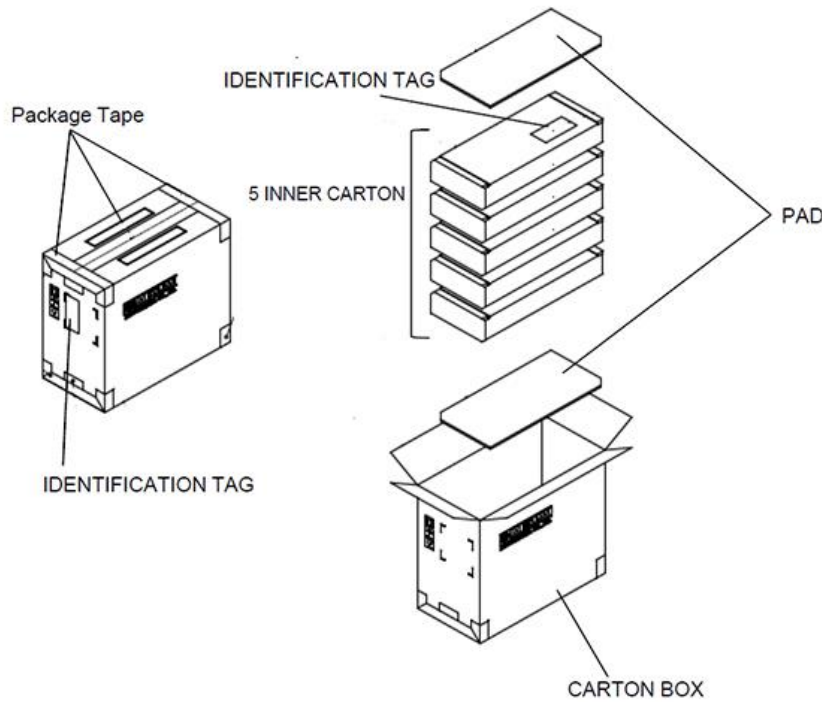

Figure 9: Inner carton

#### Notes:

- Each packing tray contains 96 products.
- Five packing trays (each with 96 products) are stacked with an empty packing tray on top. The stack is wrapped with strapping tape.
- The moisture-proof inner carton contains a total of 480 products (five trays).
- The MSL label, Lot label, and Identification tag are stuck on the moisture-proof carton.

## 16.2 Carton Box



### Notes:

- The carton box holds five inner cartons (480 products in each carton).
- The carton box contains 2400 products.
- The Identification tag is stuck on the specified location of the inner carton and carton box.

Figure 10: Carton box

## 16.3 Labels

### 16.3.1 MSL Label



Figure 11: MSL label

## 16.4 Storage Condition and Baking Information

This product should be stored in a controlled temperature and humidity conditions according to Moisture Sensitivity Level (MSL) 3.

The calculated shelf life in sealed bag: 12 months at <math>40^{\circ}\text{C}</math> and <math>90\%</math> relative humidity (RH).

After the bag is opened, the product should be mounted within 168 hours at <math>30^{\circ}\text{C}</math> and 60% RH.

If the product is not mounted within the specified time or, when the sealed bag is opened, the humidity indicator card displays >10%, the product should be baked at 48 hours at <math>125^{\circ}\text{C} \pm 5^{\circ}\text{C}</math>

## 17 REGULATORY

### 17.1 Certified Antennas

| Model                               | Type                           | Connector | 2400~2483.5MHz  |   |
|-------------------------------------|--------------------------------|-----------|---|---|
|                                     |                                |           | 5150~5250MHz  | 5250~5350MHz                              |
| Laird MAF94051                      | Dipole                         | RP-SMA    | 2.1 dBi (2.4-2.5 GHz),<br>2.6 dBi (5.25 GHz)  | 2.4 dBi (4.9 GHz),<br>3.4 dBi (5.875 GHz) |
| Laird/NanoBlade-IP04                | PCB Dipole                     | IPEX MHF  | 2 dBi (2.4-2.5 GHz),<br>3.9 dBi (5.15-5.35 GHz)                                     | 4 dBi (5.6 GHz)                           |
| Laird/MAF95310 Mini Nano Blade Flex | PCB Dipole                     | IPEX MHF  | 2.79 dBi (2.4 GHz),   | 3.38 dBi (5 GHz)                          |
| Laird/NanoBlue-IP04                 | PCB Dipole                     | IPEX MHF  | 2 dBi (2.4 GHz only)  |   |
| Ethertronics/WLAN_1000146           | Isolated<br>Magnetic<br>Dipole | IPEX MHF  | 2.5 dBi (2.390-2.490 GHz),<br>3.5 dBi (4.900-5.100, 5.150-5.350,<br>5.70-5.900 GHz) |   |

## 18 FCC AND IC REGULATORY

| Model    | US/FCC       | CANADA/IC      |
|----------|--------------|----------------|
| SSD50NBT | SQG-SSD50NBT | 3147A-SSD50NBT |

The SSD50NBT has been designed to pass certification with the antenna listed below. The required antenna impedance is 50 ohms.

| Model                                    | Type       | Connector | Peak gain ( dBi )  |                  |                  |                  |                  |
|--|------------|-----------|--------------------|------------------|------------------|------------------|------------------|
|  |            |           | 2400~2483.5<br>MHz | 5150~5250<br>MHz | 5250~5350<br>MHz | 5470~5725<br>MHz | 5725~5850<br>MHz |
| Laird<br>MAF94051                        | Dipole     | RP-SMA    | 2.1 dBi            | 2.4 dBi          | 2.6 dBi          | 3.4 dBi          |                  |
| Laird<br>NanoBlade-IP04                  | PCB Dipole | IPEX MHF  | 2 dBi              | 3.9 dBi          |                  | 4 dBi            |                  |
| Laird<br>MAF95310 Mini<br>NanoBlade Flex | PCB Dipole | IPEX MHF  | 2.79 dBi           | 3.38 dBi         |                  |                  |                  |
| Laird<br>NanoBlue-IP04                   | PCB Dipole | IPEX MHF  | 2dBi               | -                |                  |                  |                  |

| Model                        | Type                           | Connector | Peak gain ( dBi ) |               |               |               |               |  |
|------------------------------|--------------------------------|-----------|-------------------|---------------|---------------|---------------|---------------|--|
|                              |                                |           | 2400~2483.5 MHz   | 5150~5250 MHz | 5250~5350 MHz | 5470~5725 MHz | 5725~5850 MHz |  |
| Ethertronics<br>WLAN_1000146 | Isolated<br>Magnetic<br>Dipole | IPEX MHF  | 2.5dBi            | 3.5 dBi       |               |               |               |  |

## 18.1 FCC

### 18.1.1 Federal Communication Commission Interference Statement

This equipment has been tested and found to comply with the limits for a Class B digital device, pursuant to Part 15 of the FCC Rules. These limits are designed to provide reasonable protection against harmful interference in a residential installation. This equipment generates, uses and can radiate radio frequency energy and, if not installed and used in accordance with the instructions, may cause harmful interference to radio communications. However, there is no guarantee that interference will not occur in a particular installation. If this equipment does cause harmful interference to radio or television reception, which can be determined by turning the equipment off and on, the user is encouraged to try to correct the interference by one of the following measures:

- Reorient or relocate the receiving antenna.
- Increase the separation between the equipment and receiver.
- Connect the equipment into an outlet on a circuit different from that to which the receiver is connected.
- Consult the dealer or an experienced radio/TV technician for help.

#### 18.1.1.1 FCC Caution:

Any changes or modifications not expressly approved by the party responsible for compliance could void the user's authority to operate this equipment.

This device complies with Part 15 of the FCC Rules. Operation is subject to the following two conditions: (1) This device may not cause harmful interference, and (2) this device must accept any interference received, including interference that may cause undesired operation.

#### 18.1.1.2 Important Note:

##### Radiation Exposure Statement

This equipment complies with FCC radiation exposure limits set forth for an uncontrolled environment. This equipment should be installed and operated with minimum distance 20cm between the radiator and your body.

This transmitter must not be co-located or operating in conjunction with any other antenna or transmitter.

Country Code selection feature to be disabled for products marketed to the US/Canada.

##### This device is intended only for OEM integrators under the following conditions:

1. The antenna must be installed such that 20 cm is maintained between the antenna and users, and
2. The transmitter module may not be co-located with any other transmitter or antenna,
3. For all products market in US, OEM has to limit the operation channels in CH1 to CH11 for 2.4G band by supplied firmware programming tool. OEM shall not supply any tool or info to the end-user regarding to Regulatory Domain change.

As long as the three conditions above are met, further **transmitter** testing will not be required. However, the OEM integrator is still responsible for testing their end-product for any additional compliance requirements required with this module installed.

#### 18.1.1.3 Important Note:

In the event that these conditions **cannot be met** (for example certain laptop configurations or co-location with another transmitter), then the FCC authorization is no longer considered valid and the FCC ID **cannot** be used on the final product. In

these circumstances, the OEM integrator will be responsible for re-evaluating the end product (including the transmitter) and obtaining a separate FCC authorization.

### 18.1.2 End Product Labeling

This transmitter module is authorized only for use in device where the antenna may be installed such that 20 cm may be maintained between the antenna and users. The final end product must be labeled in a visible area with the following:  
**Contains FCC ID: SQG-SSD50NBT.**

### 18.1.3 Manual Information to the End User

The OEM integrator has to be aware not to provide information to the end user regarding how to install or remove this RF module in the user's manual of the end product which integrates this module.

The end user manual shall include all required regulatory information/warning as show in this manual.

## 18.2 Industry Canada

### 18.2.1 Industry Canada Statement

This device complies with Industry Canada's licence-exempt RSSs. Operation is subject to the following two conditions:

- (1) This device may not cause interference; and
- (2) This device must accept any interference, including interference that may cause undesired operation of the device.

Le présent appareil est conforme aux CNR d'Industrie Canada applicables aux appareils radio exempts de licence. L'exploitation est autorisée aux deux conditions suivantes:

- 1) l'appareil ne doit pas produire de brouillage;
- 2) l'utilisateur de l'appareil doit accepter tout brouillage radioélectrique subi, même si le brouillage est susceptible d'en compromettre le fonctionnement.

This radio transmitter (*IC: 3147A-SSD50NBT*) has been approved by *Industry Canada* to operate with the antenna types listed below with the maximum permissible gain indicated. Antenna types not included in this list, having a gain greater than the maximum gain indicated for that type, are strictly prohibited for use with this device.

Le présent émetteur radio (*IC: 3147A-SSD50NBT*) a été approuvé par Industrie Canada pour fonctionner avec les types d'antenne énumérés ci-dessous et ayant un gain admissible maximal. Les types d'antenne non inclus dans cette liste, et dont le gain est supérieur au gain maximal indiqué, sont strictement interdits pour l'exploitation de l'émetteur.

### 18.2.2 Antenna Information

| Model                              | Type                     | Connector | Peak gain ( dBi ) |               |               |               |               |
|------------------------------------|--------------------------|-----------|-------------------|---------------|---------------|---------------|---------------|
|                                    |                          |           | 2400~2483.5 MHz   | 5150~5250 MHz | 5250~5350 MHz | 5470~5725 MHz | 5725~5850 MHz |
| Laird MAF94051                     | Dipole                   | RP-SMA    | 2.1 dBi           | 2.4 dBi       | 2.6 dBi       | 3.4 dBi       |               |
| Laird NanoBlade-IP04               | PCB Dipole               | IPEX MHF  | 2 dBi             | 3.9 dBi       |               | 4 dBi         |               |
| Laird MAF95310 Mini NanoBlade Flex | PCB Dipole               | IPEX MHF  | 2.79 dBi          | 3.38 dBi      |               |               |               |
| Laird NanoBlue-IP04                | PCB Dipole               | IPEX MHF  | 2dBi              | -             |               |               |               |
| Ethertronics WLAN_1000146          | Isolated Magnetic Dipole | IPEX MHF  | 2.5dBi            | 3.5 dBi       |               |               |               |



**Caution:**

(i) the device for operation in the band 5150–5250 MHz is only for indoor use to reduce the potential for harmful interference to co-channel mobile satellite systems;

(ii) for devices with detachable antenna(s), the maximum antenna gain permitted for devices in the bands 5250-5350 MHz and 5470-5725 MHz shall be such that the equipment still complies with the e.i.r.p. limit;

(iii) for devices with detachable antenna(s), the maximum antenna gain permitted for devices in the band 5725-5850 MHz shall be such that the equipment still complies with the e.i.r.p. limits specified for point-to-point and non-point-to-point operation as appropriate; and

Operations in the 5.25-5.35GHz band are restricted to indoor usage only.

**Avertissement:**

(i) les dispositifs fonctionnant dans la bande de 5150 à 5250MHz sont réservés uniquement pour une utilisation à l'intérieur afin de réduire les risques de brouillage préjudiciable aux systèmes de satellites mobiles utilisant les mêmes canaux;

(ii) pour les dispositifs munis d'antennes amovibles, le gain maximal d'antenne permis pour les dispositifs utilisant les bandes de 5250 à 5350MHz et de 5470 à 5725 MHz doit être conforme à la limite de la p.i.r.e.;

(iii) pour les dispositifs munis d'antennes amovibles, le gain maximal d'antenne permis (pour les dispositifs utilisant la bande de 5725 à 5850 MHz) doit être conforme à la limite de la p.i.r.e. spécifiée pour l'exploitation point à point et l'exploitation non point à point, selon le cas;

Les opérations dans la bande de 5.25-5.35GHz sont limités à un usage intérieur seulement.

**18.2.2.1 Radiation Exposure Statement:**

This equipment complies with Canada radiation exposure limits set forth for an uncontrolled environment. This equipment should be installed and operated with minimum distance 20cm between the radiator & your body.

**18.2.2.2 Déclaration d'exposition aux radiations:**

Cet équipement est conforme Canada limites d'exposition aux radiations dans un environnement non contrôlé. Cet équipement doit être installé et utilisé à distance minimum de 20cm entre le radiateur et votre corps.

This device is intended only for OEM integrators under the following conditions:

1) The transmitter module may not be co-located with any other transmitter or antenna.

As long as 1 condition above are met, further transmitter test will not be required. However, the OEM integrator is still responsible for testing their end-product for any additional compliance requirements required with this module installed.

**18.2.2.3 Cet appareil est conçu uniquement pour les intégrateurs OEM dans les conditions suivantes:**

1) Le module émetteur peut ne pas être coïmplanté avec un autre émetteur ou antenne.

Tant que les 1 condition ci-dessus sont remplies, des essais supplémentaires sur l'émetteur ne seront pas nécessaires. Toutefois, l'intégrateur OEM est toujours responsable des essais sur son produit final pour toutes exigences de conformité supplémentaires requis pour ce module installé.

**IMPORTANT NOTE:**

In the event that these conditions can not be met (for example certain laptop configurations or co-location with another transmitter), then the Canada authorization is no longer considered valid and the IC ID can not be used on the final product. In these circumstances, the OEM integrator will be responsible for re-evaluating the end product (including the transmitter) and obtaining a separate Canada authorization.

**NOTE IMPORTANTE:**

Dans le cas où ces conditions ne peuvent être satisfaites (par exemple pour certaines configurations d'ordinateur portable ou de certaines co-localisation avec un autre émetteur), l'autorisation du Canada n'est plus considéré comme valide et l'ID IC ne peut pas être utilisé sur le produit final. Dans ces circonstances, l'intégrateur OEM sera chargé de réévaluer le produit final (y compris l'émetteur) et l'obtention d'une autorisation distincte au Canada.

#### 18.2.2.4 End Product Labeling

The final end product must be labeled in a visible area with the following: "Contains IC: 3147A-SSD50NBT".

#### Plaque signalétique du produit final

Le produit final doit être étiqueté dans un endroit visible avec l'inscription suivante: "Contient des IC: 3147A-SSD50NBT".

#### 18.2.2.5 Manual Information to the End User

The OEM integrator has to be aware not to provide information to the end user regarding how to install or remove this RF module in the user's manual of the end product which integrates this module.

The end user manual shall include all required regulatory information/warning as show in this manual.

#### 18.2.2.6 Manuel d'information à l'utilisateur final

L'intégrateur OEM doit être conscient de ne pas fournir des informations à l'utilisateur final quant à la façon d'installer ou de supprimer ce module RF dans le manuel de l'utilisateur du produit final qui intègre ce module.

Le manuel de l'utilisateur final doit inclure toutes les informations réglementaires requises et avertissements comme indiqué dans ce manuel.

## 19 EUROPEAN UNION REGULATORY

The SSD50NBT has been tested for compliance with relevant standards for the EU market. SSD50NBT module was tested with antennas listed below.

| Model                               | Type                           | Connector | 2400~2483.5MHz  |   |
|-------------------------------------|--------------------------------|-----------|---|---|
|                                     |                                |           | 5150~5250MHz  | 5250~5350MHz<br>5470~5725MHz 5725~5850MHz |
| Laird MAF94051                      | Dipole                         | RP-SMA    | 2.1 dBi (2.4-2.5 GHz), 2.4 dBi (4.9 GHz)<br>2.6 dBi (5.25 GHz), 3.4 dBi (5.875 GHz) |   |
| Laird/NanoBlade-IP04                | PCB Dipole                     | IPEX MHF  | 2 dBi (2.4-2.5 GHz),<br>3.9 dBi (5.15-5.35 GHz), 4 dBi (5.6 GHz)                    |   |
| Laird/MAF95310 Mini Nano Blade Flex | PCB Dipole                     | IPEX MHF  | 2.79 dBi (2.4 GHz), 3.38 dBi (5 GHz)  |   |
| Laird/NanoBlue-IP04                 | PCB Dipole                     | IPEX MHF  | 2 dBi (2.4 GHz only)  |   |
| Ethertronics/WLAN_1000146           | Isolated<br>Magnetic<br>Dipole | IPEX MHF  | 2.5 dBi (2.390-2.490 GHz),<br>3.5 dBi (4.900-5.100, 5.150-5.350,<br>5.70-5.900 GHz) |   |

The OEM should consult with a qualified test house before entering their device into an EU member country to make sure all regulatory requirements have been met for their complete device.

Reference the Declaration of Conformities listed below for a full list of the standards that the modules were tested to. Test reports are available upon request.

### 19.1 EU Declarations of Conformity

|                     |       |
|---------------------|-------|
| <b>Manufacturer</b> | Laird |
|---------------------|-------|

|                            |  |
|----------------------------|--|
| <b>Products</b>            | SSD50NBT   |
| <b>Product Description</b> | 802.11 a/b/g/n Enterprise Wi-Fi + Bluetooth SiP module |
| <b>EU Directives</b>       | 2014/53/EU – Radio Equipment Directive (RED)           |



**Reference standards used for presumption of conformity:**

| Article Number | Requirement   | Reference standard(s)   |
|----------------|---|---|
| 3.1a           | Low voltage equipment safety  | EN 60950-1:2006 +A11:2009 +A1:2010 +A12:2011 +A2:2013           |
|                | RF Exposure   | EN 62311:2008   |
| 3.1b           | Protection requirements with respect to electromagnetic compatibility | EN 301 489-1 v2.2.0 (2017-03)<br>EN 301 489-17 v3.2.0 (2017-03) |
| 3.2            | Protection requirements – Electromagnetic compatibility               | EN 300 328 v2.1.1 (2016-11)<br>EN 301 893 v2.1.1 (2017-05)      |

**Declaration:**

We, Laird, declare under our sole responsibility that the essential radio test suites have been carried out and that the above product to which this declaration relates is in conformity with all the applicable essential requirements of Article 3 of the EU Directive 2014/53/EU, when used for its intended purpose.

|                                 |   |
|---------------------------------|---|
| Place of Issue:                 | Laird<br>W66N220 Commerce Court, Cedarburg, WI 53012 USA<br>tel: +1-262-375-4400 fax: +1-262-364-2649 |
| Date of Issue:                  | June 2017   |
| Name of Authorized Person:      | Thomas T Smith, Director of EMC Compliance  |
| Signature of Authorized Person: |   |

**Maximum Output Power for Each Frequency**

|                                      |                          |
|--------------------------------------|--------------------------|
| 20.00 dBm, 2.4G: 2.412 GHZ~2.472 GHZ | 22.80 dBm, 5.15-5.25GHz  |
| 10.00 dBm, for BT                    | 22.60 dBm, 5.25-5.35GHz  |
| 10.00 dBm, for BT LE                 | 22.60 dBm, 5.47-5.725GHz |

**Software Version for Testing**

SW version: 3.5.2.15

The minimum distance between the user and/or any bystander and the radiating structure of the transmitter is 20 cm.

5150 ~ 5350 MHz is limited to indoor used in the following countries:

|  |    |    |    |    |    |    |    |    |    |    |    |
|--|----|----|----|----|----|----|----|----|----|----|----|
|  | BE | DK | IE | FR | CY | LU | NL | PT | SK | UK | NO |
|  | BG | DE | EL | HR | LV | HU | AT | RO | FI | LI | TR |
|  | CZ | EE | ES | IT | LT | MT | PL | SI | SE | IS | CH |

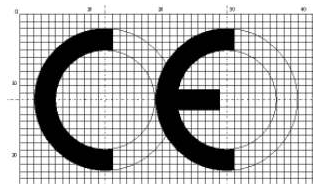

## 20 ORDERING INFORMATION

| Part Number | Description                                     |
|-------------|---|
| SSD50NBT    | 2X2 802.11 a/b/g/n with BT4.0 dual mode module. |

### 20.1 General Comments

Please check with Laird for the latest information before commencing a design. If in doubt, ask.

|                                     |  |
|-------------------------------------|--|
| <b>cs</b> Český<br>[Czech]          | <i>[Jméno výrobce]</i> tímto prohlašuje, že tento <i>[typ zařízení]</i> je ve shodě se základními požadavky a dalšími příslušnými ustanoveními směrnice 1999/5/ES.   |
| <b>da</b> Dansk<br>[Danish]         | Undertegnede <i>[fabrikantens navn]</i> erklærer herved, at følgende udstyr <i>[udstyrets typebetegnelse]</i> overholder de væsentlige krav og øvrige relevante krav i direktiv 1999/5/EF.   |
| <b>de</b> Deutsch<br>[German]       | Hiermit erkläre <i>[Name des Herstellers]</i> , dass sich das Gerät <i>[Gerätetyp]</i> in Übereinstimmung mit den grundlegenden Anforderungen und den übrigen einschlägigen Bestimmungen der Richtlinie 1999/5/EG befindet.          |
| <b>et</b> Eesti<br>[Estonian]       | Käesolevaga kinnitab <i>[tootja nimi = name of manufacturer]</i> seadme <i>[seadme tüüp = type of equipment]</i> vastavust direktiivi 1999/5/EÜ põhinõuetele ja nimetatud direktiivist tulenevatele teistele asjakohastele sätetele. |
| <b>en</b> English                   | Hereby, <i>[name of manufacturer]</i> , declares that this <i>[type of equipment]</i> is in compliance with the essential requirements and other relevant provisions of Directive 1999/5/EC.   |
| <b>es</b> Español<br>[Spanish]      | Por medio de la presente <i>[nombre del fabricante]</i> declara que el <i>[clase de equipo]</i> cumple con los requisitos esenciales y cualesquiera otras disposiciones aplicables o exigibles de la Directiva 1999/5/CE.            |
| <b>el</b> Ελληνική<br>[Greek]       | ΜΕ ΤΗΝ ΠΑΡΟΥΣΑ <i>[name of manufacturer]</i> ΔΗΛΩΝΕΙ ΟΤΙ <i>[type of equipment]</i> ΣΥΜΜΟΡΦΩΝΕΤΑΙ ΠΡΟΣ ΤΙΣ ΟΥΣΙΩΔΕΙΣ ΑΠΑΙΤΗΣΕΙΣ ΚΑΙ ΤΙΣ ΛΟΙΠΕΣ ΣΧΕΤΙΚΕΣ ΔΙΑΤΑΞΕΙΣ ΤΗΣ ΟΔΗΓΙΑΣ 1999/5/ΕΚ.   |
| <b>fr</b> Français<br>[French]      | Par la présente <i>[nom du fabricant]</i> déclare que l'appareil <i>[type d'appareil]</i> est conforme aux exigences essentielles et aux autres dispositions pertinentes de la directive 1999/5/CE.                                  |
| <b>it</b> Italiano<br>[Italian]     | Con la presente <i>[nome del costruttore]</i> dichiara che questo <i>[tipo di apparecchio]</i> è conforme ai requisiti essenziali ed alle altre disposizioni pertinenti stabilite dalla direttiva 1999/5/CE.                         |
| <b>lv</b> Latviski<br>[Latvian]     | Aršo <i>[name of manufacturer /izgatavotājanosaukums]</i> deklarē, ka <i>[type of equipment / iekārtas tips]</i> atbilst Direktīvas 1999/5/EK būtiskajām prasībām un citiemar to saistītajiem noteikumiem.                           |
| <b>lt</b> Lietuvių<br>[Lithuanian]  | Šiuo <i>[manufacturer name]</i> deklaruoją, kad šis <i>[equipment type]</i> atitinka esminius reikalavimus ir kitas 1999/5/EB Direktyvos nuostatas.  |
| <b>nl</b> Nederlands<br>[Dutch]     | Hierbij verklaart <i>[naam van de fabrikant]</i> dat het toestel <i>[type van toestel]</i> in overeenstemming is met de essentiële eisen en de andere relevante bepalingen van richtlijn 1999/5/EG.                                  |
| <b>mt</b> Malti<br>[Maltese]        | Hawnhekk, <i>[isem tal-manifattur]</i> , jiddikjara li dan <i>[il-mudel tal-prodott]</i> jikkonforma mal-ħtiġijiet essenzjali u ma provvedimenti oħrajn rilevanti li hemm fid-Dirrettiva 1999/5/EC.                                  |
| <b>hu</b> Magyar<br>[Hungarian]     | Alulírott, <i>[gyártó neve]</i> nyilatkozom, hogy a <i>[... típus]</i> megfelel a vonatkozó alapvető követelményeknek és az 1999/5/EC irányelv egyéb előírásainak.   |
| <b>pl</b> Polski<br>[Polish]        | Niniejszym <i>[nazwa producenta]</i> oświadczam, że <i>[nazwa wyrobu]</i> jest zgodny z zasadniczymi wymogami oraz pozostałymi stosownymi postanowieniami Dyrektywy 1999/5/EC.   |
| <b>pt</b> Português<br>[Portuguese] | <i>[Nome do fabricante]</i> declara que este <i>[tipo de equipamento]</i> está conforme com os requisitos essenciais e outras disposições da Directiva 1999/5/CE.  |
| <b>sl</b> Slovensko<br>[Slovenian]  | <i>[Ime proizvajalca]</i> izjavlja, da je ta <i>[tip opreme]</i> v skladu z bistvenimi zahtevami in ostalimi relevantnimi določili direktive 1999/5/ES.  |

|                                       |   |
|---------------------------------------|---|
| <b>Slovensky</b><br><b>[Slovak]</b>   | <i>[Menovýrobcu] týmto vyhlasuje, že [typzariadenia] spĺňa základné požiadavky a všetky príslušné ustanovenia Smernice 1999/5/ES.</i>   |
| <b>fi Suomi</b><br><b>[Finnish]</b>   | <i>[Valmistaja = manufacturer] vakuuttaa täten että [type of equipment = laitteen tyyppimerkintä] tyyppinen laite on direktiivin 1999/5/EY oleellisten vaatimusten ja sitä koskevien direktiivin muiden ehtojen mukainen.</i> |
| <b>sv Svenska</b><br><b>[Swedish]</b> | <i>Härmed intygar [företag] att denna [utrustningstyp] står i överensstämmelse med de väsentliga egenskapskrav och övriga relevanta bestämmelser som framgår av direktiv 1999/5/EG.</i>                                       |

© Copyright 2018 Laird. All Rights Reserved. Any information furnished by Laird and its agents is believed to be accurate and reliable. All specifications are subject to change without notice. Responsibility for the use and application of Laird materials or products rests with the end user since Laird and its agents cannot be aware of all potential uses. Laird makes no warranties as to non-infringement nor as to the fitness, merchantability, or sustainability of any Laird materials or products for any specific or general uses. Laird, Laird Technologies, Inc., or any of its affiliates or agents shall not be liable for incidental or consequential damages of any kind. All Laird products are sold pursuant to the Laird Terms and Conditions of Sale in effect from time to time, a copy of which will be furnished upon request. When used as a tradename herein, *Laird* means Laird PLC or one or more subsidiaries of Laird PLC. Laird™, Laird Technologies™, corresponding logos, and other marks are trademarks or registered trademarks of Laird. Other marks may be the property of third parties. Nothing herein provides a license under any Laird or any third party intellectual property right.