

WSA48M- (1) (2) (3) (4) (5) (6)

SWITCH FUNCTION CODE	SWITCH FUNCTION DESCRIPTION
2	MECHANICAL, MAINTAIN, SOLDER TERMINAL
B	MECHANICAL, MAINTAIN, NO/NO WIRELEADS
D	MECHANICAL, MAINTAIN, NC/NC WIRELEADS
F	MECHANICAL, MAINTAIN, NO/NC WIRELEADS

HOUSING MATERIAL CODE	HOUSING DESCRIPTION
1	STAINLESS STEEL
2	ZINC ALLOY CHROME PLATED
3	AL ALLOY ANODIZED BLACK

BUTTON TYPE CODE	BUTTON TYPE DESCRIPTION
0	NON-ILLUMINATION
1	CENTER SPOT ILLUMINATION
2	RING ILLUMINATION
3	POWER/STANDBY ILLUMINATION

LED COLOR CODE	LED COLOR
N	NONE
R	RED
B	BLUE
G	GREEN
Y	YELLOW
W	WHITE

LED INLET VOLTAGE CODE		LED INLET VOLTAGE
NON-WIRELEADS	IF BLANK*	FOLLOW LED SPECIFICATION
WIRELEADS	IF BLANK*	FOLLOW LED SPECIFICATION
	05	5V
	12	12V
	24	24V

ANY CODE	DESCRIPTION
IF BLANK*	NA
XXX	PER CUSTOMER SPECIAL REQUEST

**MECHANICAL CHARACTERISTICS:**

SWITCH CIRCUITRY: SPDT-DB  
 SWITCH ACTION: MAINTAINED (PER CHART)  
 PRE-TRAVEL: 1.27 mm NOMINAL  
 OVER-TRAVEL: 0.254 mm NOMINAL  
 TOTAL TRAVEL: 1.524 mm NOMINAL  
 OPERATING FORCE: 525 g [5.15N] NOMINAL  
 RELEASEING FORCE: 340 g [3.45N] NOMINAL  
 PANEL THICKNESS:  
 MOUNT: 0.5-4.5mm  
 CONTACTS: SILVER  
 NUT TORQUE FORCE: MAX 11.5 kgf\*cm [10 LB\*in]

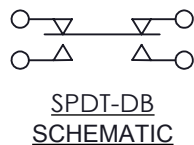

**ELECTRICAL LIFE:**

MAINTAINED: 5A@28VDC, 25K CYCLES NOMINAL

**ENVIROMENTAL SPECIFICATIONS:**

OPERATING TEMPERATURE: -40 °C to +85 °C [-40 °F to +185 °F]  
 IP67 COMPLIANT

**ELECTRICAL SPECIFICATIONS:**

DIELECTRIC STRENGTH: 1,000VAC  
 INSULATION RESISTANCE: 1G OHM  
 CONTACT RESISTANCE:  
 50m /250m OHMS MAX INITIAL (NON-WIRELEAD / WIRELEADS)

**LED SPECIFICATIONS:**

SEE LED SPECIFICATION

CERTIFICATION: UL 61058

\* NOTE:

1. SUPPLY HEX NUT AND SEALING WASHER BULK IN PACKED

LED SPECIFICATION				
LED CODE	LED Color	CIRCUITRY	Vf(VDC)	If
			Color	(mA)
R	RED		1.8 ~ 2.5	20
B	BLUE		2.8 ~ 3.5	20
G	GREEN		2.8 ~ 3.5	20
Y	YELLOW		1.8 ~ 2.5	20
W	WHITE		2.8 ~ 3.5	20

Notes:  
 Hand Soldering Temperature (4mm above from Body) : 320°C for 3 seconds

WIRELEADS SPECIFICATION					
WIRELEADS TYPE	WIRELEADS SPECIFICATION	SW TERMINAL	SW TERMINAL	LED COLOR	
		NO	NC	+	-
ILLUMINATION	AWG24 / UL1007	BLUE	YELLOW	RED	BLACK
NON-ILLUMINATION		BLUE	YELLOW	-	-

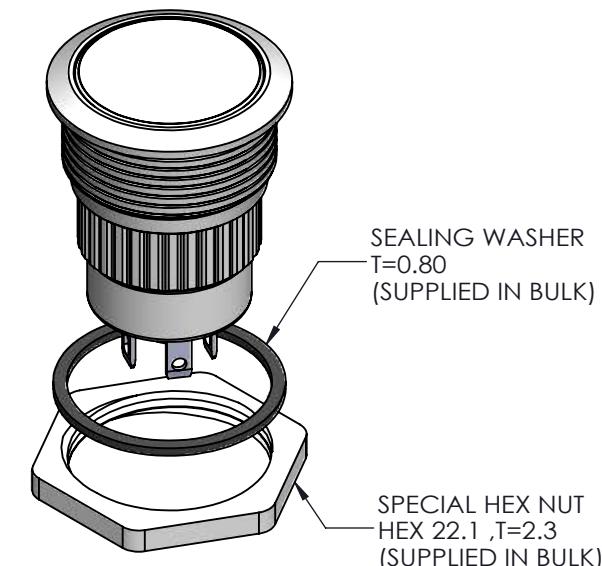

DWG TYPE SALES DRAWING	DRAWN <i>K.Y.</i>	TOLERANCES: UNLESS OTHERWISE NOTED X.X ± 0.5 X.XX ± 0.2 ANGULAR ± 1°	DWG TITLE WSA48M-MECHANICAL MAINTAIN, NONE/CENTER SPOT/ POWER STANDBY SYMBOL ILLUMINATION		
STATUS RELEASE	REVIEW <i>A.H.</i>	THIRD ANGLE PROJECTION 	DWG NO. WSA48M-2,B,D,F		
<small>This document is the intellectual property of ITW Electronic Business Asia Co., Limited and may contain confidential, proprietary, privileged information protected by law. Neither this document nor any information it contains can be reproduced, transformed to any other format, or distributed, without written permission by ITW Electronic Business Asia Co., Limited.                  本文作為安達維百電有限公司之智慧財產，非經許可不得翻取、複製、轉變成其他形式使用或散佈。</small>		DATE 2017/12/12	REF: 48M-1, 2, 5, 6, A, B	<input checked="" type="checkbox"/> 管制文件 <input type="checkbox"/> 非管制文件	
Unit mm	SCALE 3:2	REV 4	RoHS Compliant	SHEET 1 OF 3	

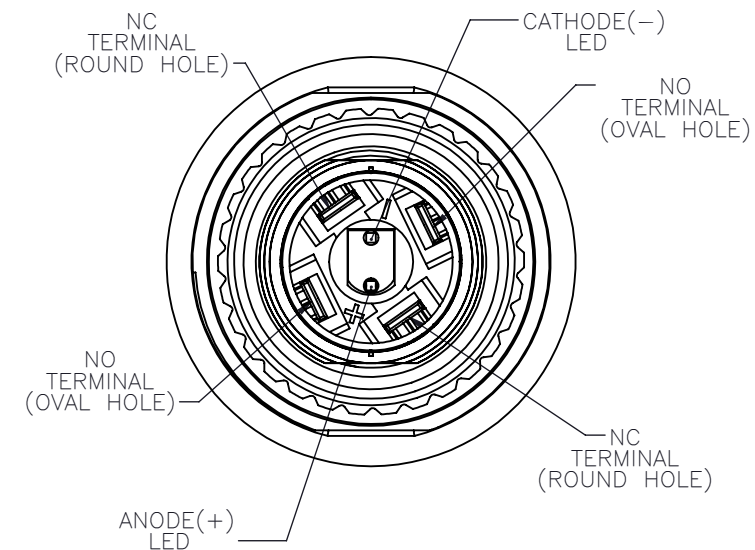
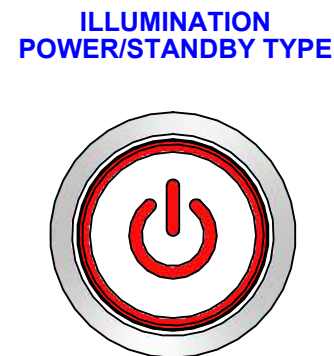
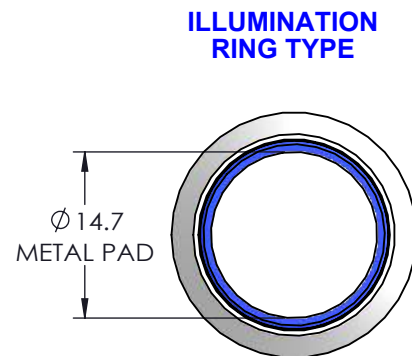
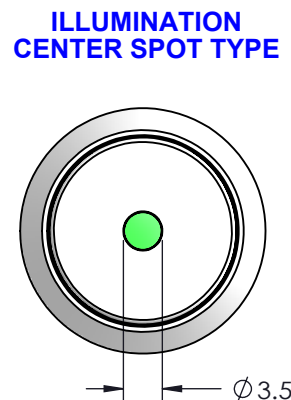
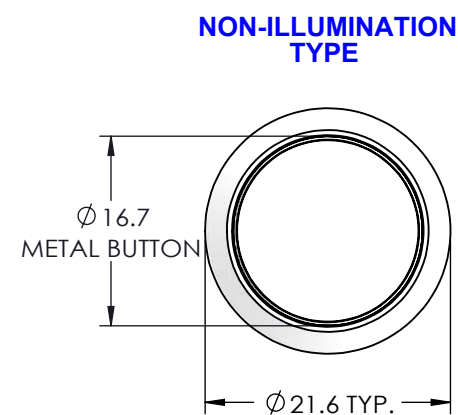

**DETAIL FOR TERMINAL POSITION**  
SCALE: 3:1

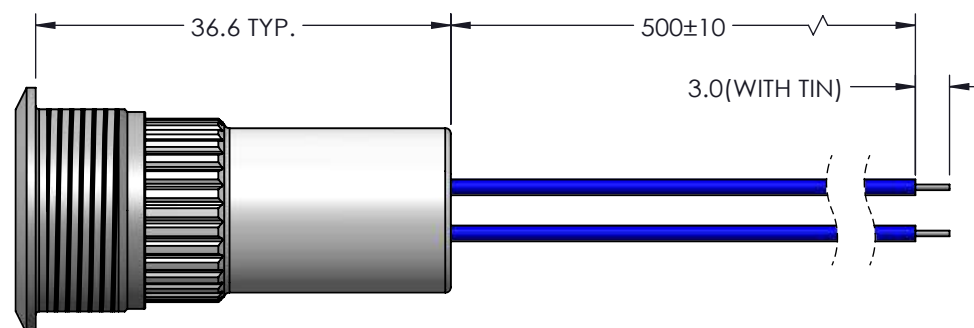
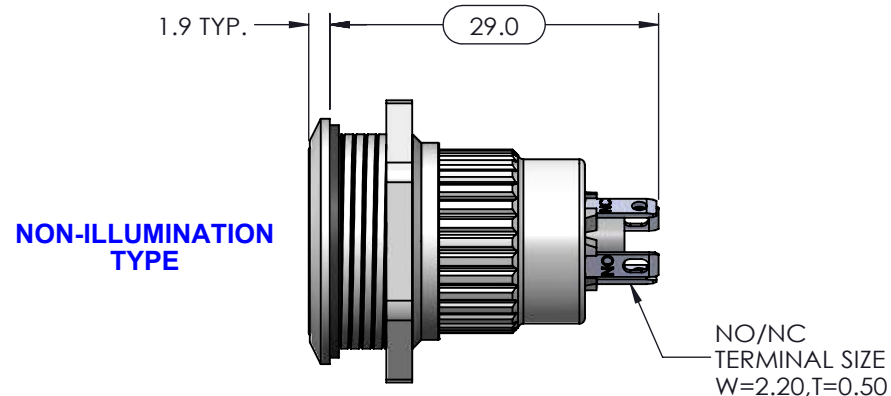

FLAT SIDE (ONLY FOR POWER/STANDBY SYMBOL ALIGNMENT)

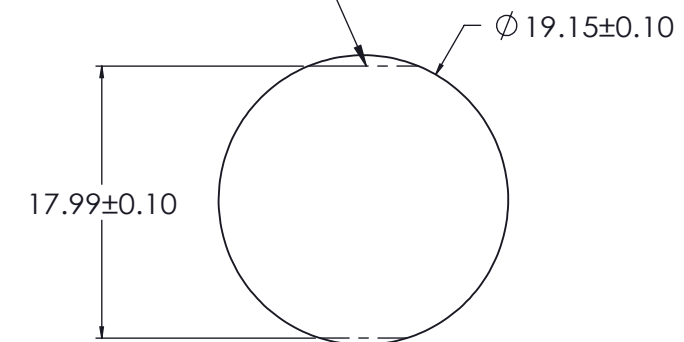
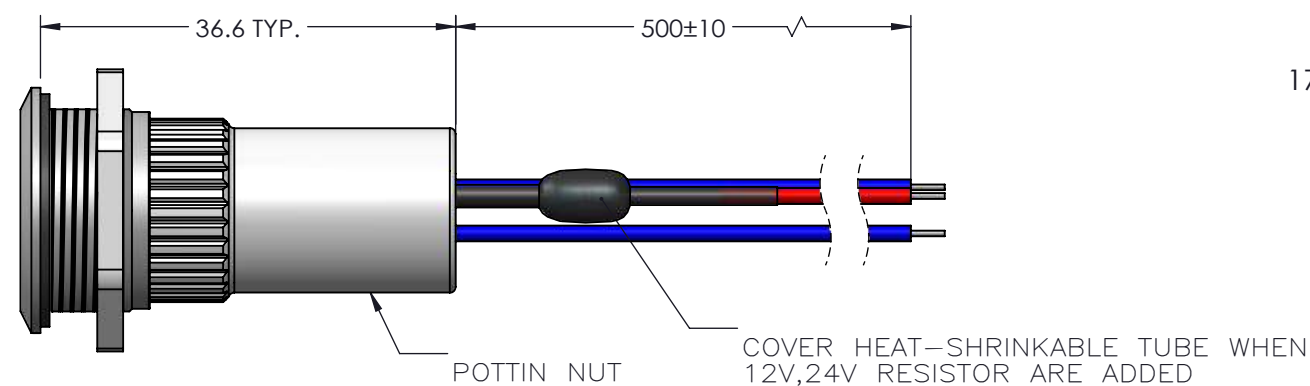
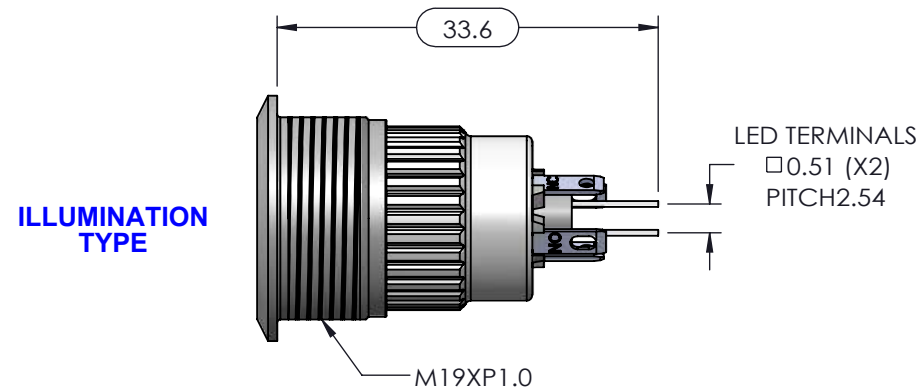

**RECOMMENDED PANEL CUT-OUT**  
SCALE: 2:1

DWG TYPE SALES DRAWING	DRAWN <i>K.Y.</i>	TOLERANCES: UNLESS OTHERWISE NOTED X.X ± 0.5 X.XX ± 0.2 ANGULAR ± 1°	DWG TITLE WSA48M-MECHANICAL MAINTAIN, NONE/CENTER SPOT/ POWER STANDBY SYMBOL ILLUMINATION							
STATUS RELEASE	REVIEW <i>A.H.</i>	THIRD ANGLE PROJECTION 	DWG NO. WSA48M-2,B,D,F							
<small>This document is the intellectual property of ITW Electronic Business Asia Co., Limited and may contain confidential, proprietary, privileged information protected by law. Neither this document nor any information it contains can be reproduced, transformed to any other format, or distributed, without written permission by ITW Electronic Business Asia Co., Limited. 本文作為安達維百電股份有限公司之智慧財產，非經許可不得翻取、複製、轉變成其他形式使用或散佈。</small>			DATE 2017/12/12	REF: 48M-1, 2, 5, 6, A, B	<input checked="" type="checkbox"/> 管制文件 <input type="checkbox"/> 非管制文件	Unit mm	SCALE 3:2	REV 4	RoHS Compliant	SHEET 2 OF 3