



1845 MHz Bandstop Notch Filter



ANATECH ELECTRONICS INC
RF & Microwave Filters & Products

Part Number: AE1845NS2182

Electrical Specifications

Notch Center Frequency: 1845 MHz
Notch Bandwidth: 70 MHz (1810-1880 MHz)
Notch Rejection: 50.0 dB Min
Passband Below Notch: 80-1740 MHz
Passband Above Notch: 1960-6000 MHz
Low Side Passband Insertion Loss: <3.2 dB @ 1740 MHz
High Side Passband Insertion Loss: <3 dB @ 1960 MHz
Return Loss: >15 dB
Impedance: 50 Ω
Power Handling: 2 Watts Max

Mechanical

Connector Type: SMA (F)
Dimensions: 1.63 x 1.38 x 0.63 Inches

Environmental

Operating Temperature: -20 to +70° C

Outline Drawing:

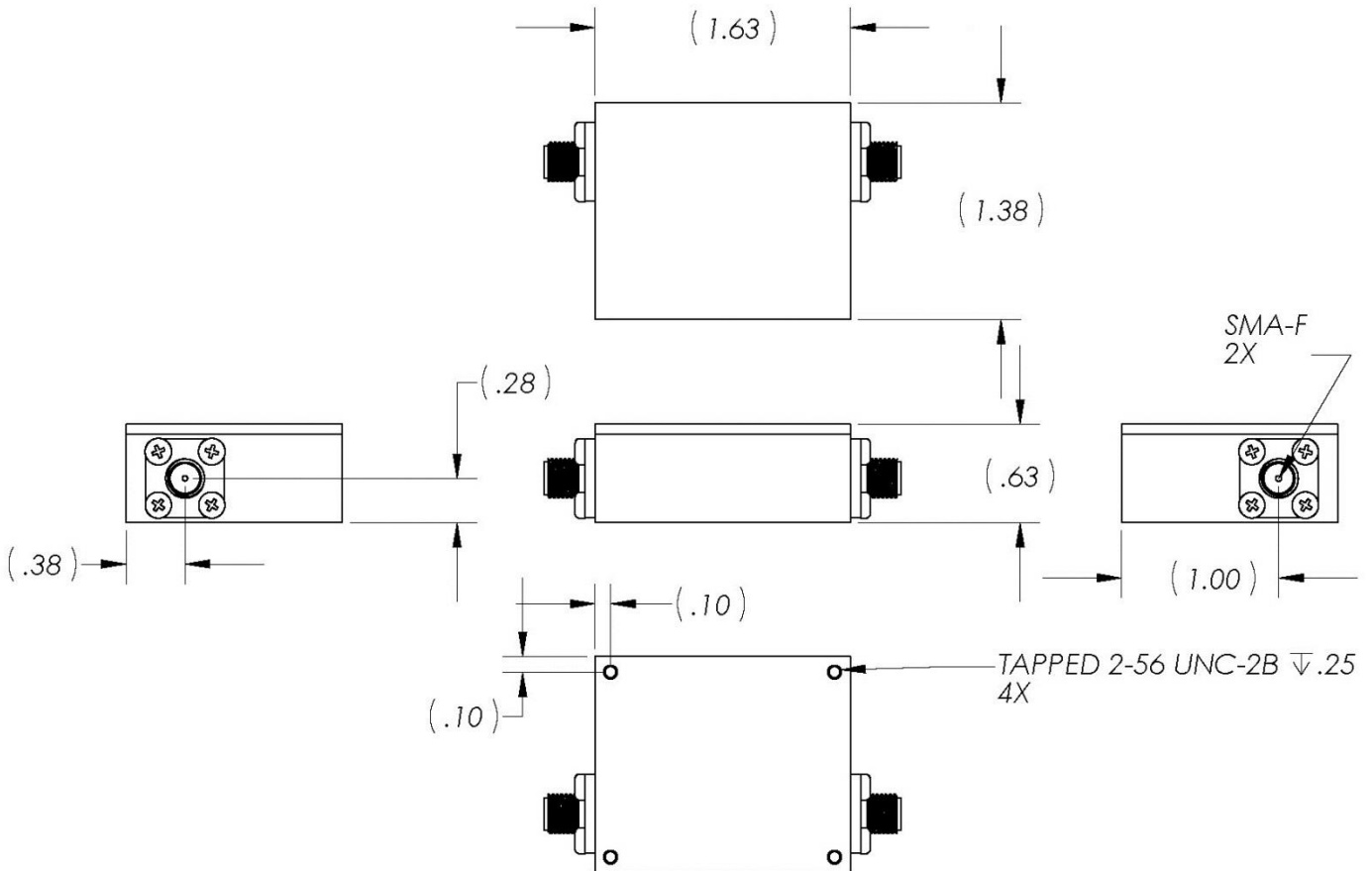



1845 MHz Bandstop Notch Filter

Part Number: AE1845NS2182



Response Plot:

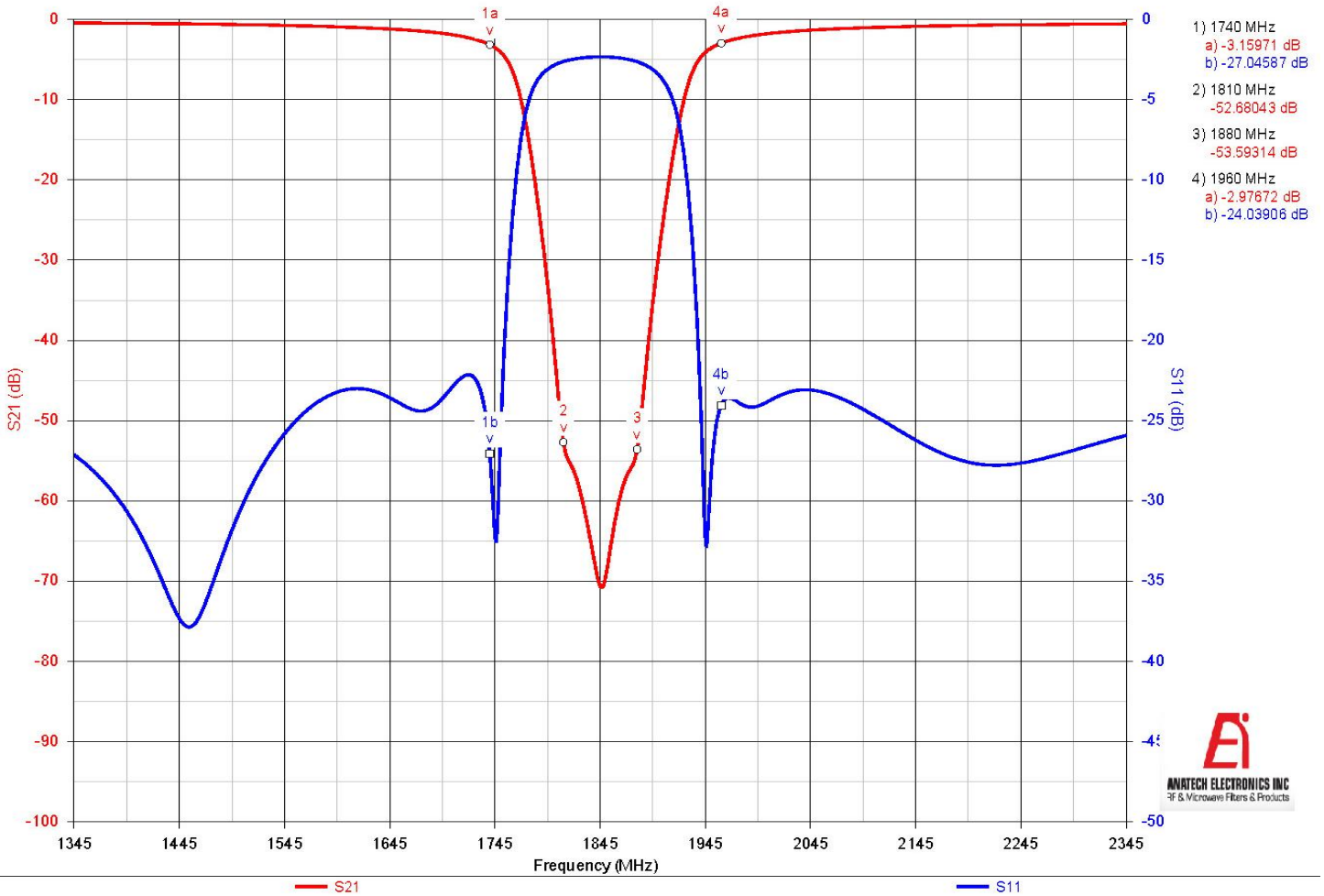

Note: This is a simulation plot. Actual results may differ once the product is implemented.



1845 MHz Bandstop Notch Filter

Part Number: AE1845NS2182



Response Plot:

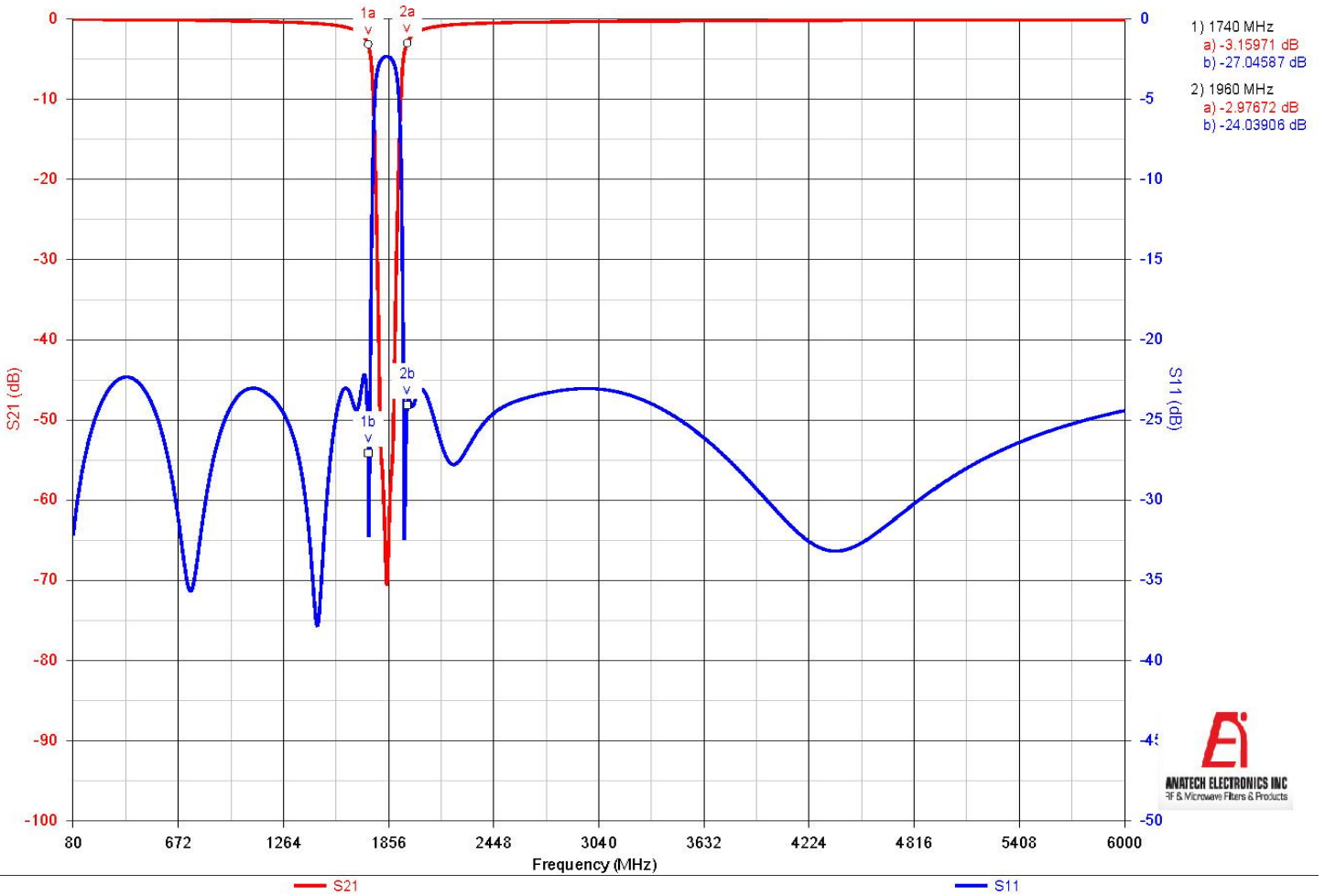

Note: This is a simulation plot. Actual results may differ once the product is implemented.