

# Information of Discontinued Models

## Terminal connection type photoelectric sensor VF2 series

Order cut-off date: 30 Sep 2006  
Date of production discontinuance: 31 Mar 2007

### Discontinued models

Terminal connection type photoelectric sensor VF2 series



### Recommended replacements

Terminal connection type multi-voltage photoelectric sensor VF series

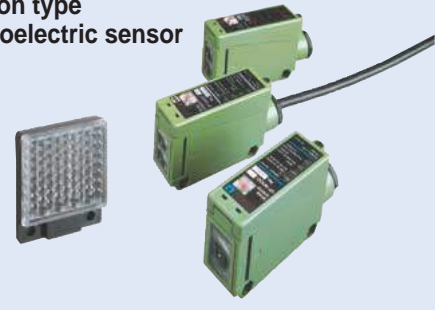

※Confirm that table in

Main points of difference between recommended replacements and discontinued models for details on model numbers for each type.

Refer to 'Sensor general catalog '03-'04 or SUNX website: <http://www.sunx.co.jp/> for details.

## Advantages of switching to recommended replacements

### Multi-voltage

Because it can function with 24 to 240 V AC or 12 to 240 V DC, which makes it suitable for supply voltages all over the world.

### Timer function models

Equipped with a timer which includes a convenient function for freely changing the sensing signal. It is also suitable for PLC input.

## Notes on using recommended replacements

Recommended replacements	Sensing performance	Specifications	Output circuit	Mounting dimensions	Dimensions	Enclosure color
VF series	◎	○	※	◎	◎	◎

◎: Highly interchangeable ○: Almost no difference  
※: Large differences -: No corresponding item or model

- High degree of interchangeability in specifications, mounting dimensions and operability, so that replacement can be carried out smoothly.
- The VF2 series and the VF series have different output circuits.  
VF2 series: NPN universal transistor / PNP open-collector transistor (two outputs)  
VF series: Relay contact 1a

## Main points of difference between recommended replacements and discontinued models

Discontinued models		Recommended replacements		Main points of difference from discontinued models
• Thru-beam type		• Thru-beam type		
Model No.	Sensing range	Model No.	Sensing range	
VF2-M10	10 m 32.808 ft	VF-M10	10 m 32.808 ft	Notes: 1) Equipped timer function type.
		VF-M10T (Note 1)	10 m 32.808 ft	
• Retroreflective type		• Retroreflective type		
Model No.	Sensing range	Model No.	Sensing range	
VF2-RM5	0.1 to 5 m 0.328 to 16.404 ft	VF-RM5	0.1 to 5 m 0.328 to 16.404 ft	Notes: 2) Equipped timer function type.
		VF-RM5T (Note 2)	0.1 to 5 m 0.328 to 16.404 ft	
• Retroreflective type (With polarizing filters)		• Retroreflective type (With polarizing filters)		
Model No.	Sensing range	Model No.	Sensing range	
VF2-PRM3	0.2 to 3 m 0.656 to 9.843 ft	VF-PRM3	0.2 to 3 m 0.656 to 9.843 ft	
• Diffuse reflective type		• Diffuse reflective type		
Model No.	Sensing range	Model No.	Sensing range	
VF2-D500	500 mm 19.685 in	VF-D500	500 mm 19.685 in	Notes: 3) Equipped timer function type.
		VF-D500T (Note 3)	500 mm 19.685 in	
		VF-D1000	1 m 0.039 ft	
		VF-D1000T (Note 3)	1 m 0.039 ft	

# Information of Discontinued Models

## Terminal connection type photoelectric sensor VF2 series

### Dimensions (Unit: mm in)

#### Discontinued models

#### VF2 series

#### VF2-M10, VF2-RM5, VF2-D500

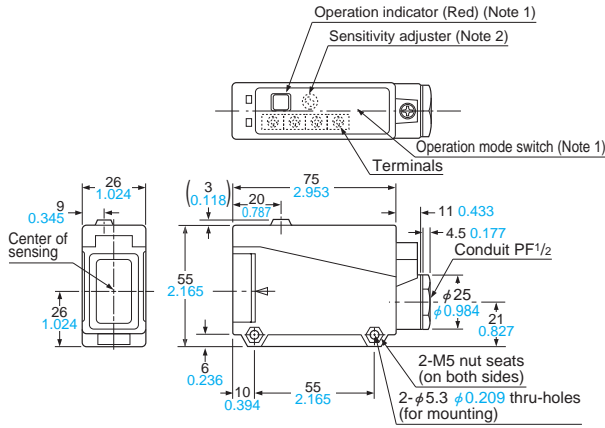

- Notes: 1) All units, except emitters, are incorporated with operation indicators.  
 2) Only the diffuse reflective type sensor is incorporated with the sensitivity adjuster.

#### VF2-PRM3

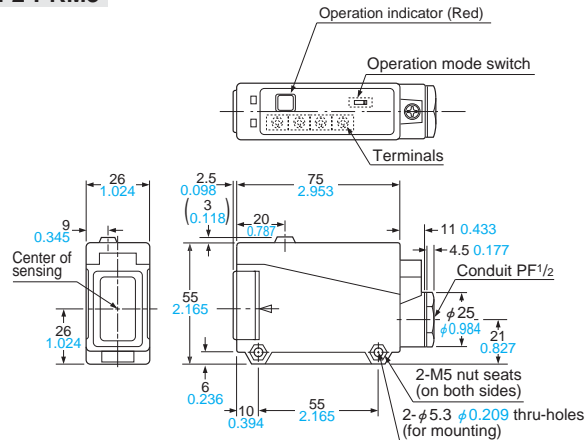

#### Recommended replacements

#### VF series

#### VF-M10, VF-RM5, VF-D500, VF-D1000

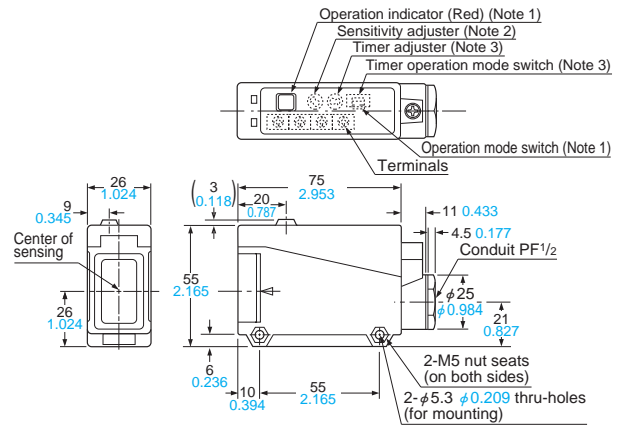

- Notes: 1) All units, except emitters, are incorporated with operation indicators.  
 2) Only the diffuse reflective type sensor is incorporated with the sensitivity adjuster.  
 3) Only the timer incorporated type sensors have the timer adjuster and timer operation mode switch.

#### VF-PRM3

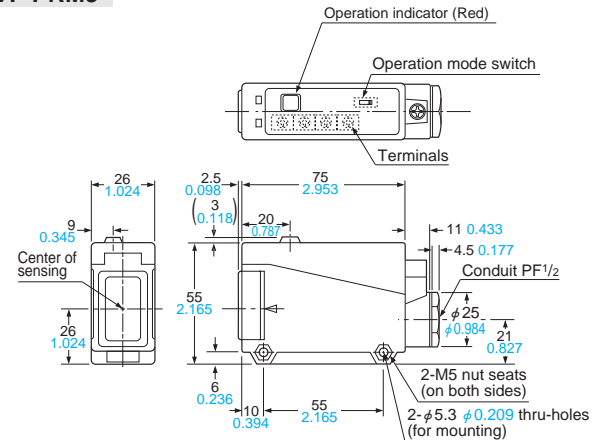

# Information of Discontinued Models

## Terminal connection type photoelectric sensor VF2 series

### Main rated specification

Item	Type Model No. (Note)	Discontinued models				Recommended replacements				
		Thru-beam	Retroreflective	With polarizing filters	Diffuse reflective	Thru-beam	Retroreflective	With polarizing filters	Diffuse reflective	
		VF2-M10	VF2-RM5	VF2-PRM3	VF2-D500	VF-M10(T)	VF-RM5(T)	VF-PRM3	VF-D500(T)	VF-D1000(T)
Sensing range		10 m 32.808 ft	0.1 to 5 m 0.328 to 16.404 ft	0.2 to 3 m 0.656 to 9.843 ft	500 mm 19.685 in	10 m 32.808 ft	0.1 to 5 m 0.328 to 16.404 ft	0.2 to 3 m 0.656 to 9.843 ft	500 mm 19.685 in	1 m 3.281 ft
Sensing object		φ20 mm φ0.787 in or more opaque object	φ50 mm φ1.969 in or more opaque or translucent object	φ50 mm φ1.969 in or more opaque, translucent or specular object	Opaque, translucent or transparent object	φ20 mm φ0.787 in or more opaque object	φ50 mm φ1.969 in or more opaque or translucent object	φ50 mm φ1.969 in or more opaque, translucent or specular object	Opaque, translucent or transparent object	
Hysteresis		—			10 % or less of operation distance	—			15 % or less of operation distance	
Supply voltage		12 ± 24 V DC ± 10 % Ripple P-P 10 % or less				24 to 240 V AC ± 10 % or 12 to 240 V DC ± 10 %				
Sensing output		NPN universal transistor <ul style="list-style-type: none"> <li>• Maximum sink current: 100 mA</li> <li>• Residual voltage: 1 V or less (at 100 mA sink current) 0.4 V or less (at 16 mA sink current)</li> </ul> PNP open-collector transistor <ul style="list-style-type: none"> <li>• Maximum source current: 100 mA</li> <li>• Residual voltage: 3 V or less (at 100 mA source current)</li> </ul>				Relay contact 1a <ul style="list-style-type: none"> <li>• Switching capacity: 250 V 1A AC (resistive load) 30 V 2A DC (resistive load)</li> <li>• Electrical life: 500,000 or more switching operations (switching frequency 3,600 operations/hour)</li> <li>• Mechanical life: 100 million or more switching operations (switching frequency 36,000 operations/hour)</li> </ul>				
Output operation		Switchable either Light-ON or Dark-ON								
Response time		3 ms or less				20 ms or less				
Protection		IP66 (IEC)								
Ambient temperature		- 10 to + 60 °C + 14 to + 140 °F (No dew condensation or icing allowed), Storage: - 20 to + 70 °C - 4 to + 158 °F								
Emitting element		Infrared LED (modulated)	Red LED (modulated)	Infrared LED (modulated)	Infrared LED (modulated)	Infrared LED (modulated)	Red LED (modulated)	Infrared LED (modulated)		
Material		Enclosure: PBT, Lens: Acrylic (front surface of VF2-PRM3 and VF-PRM3: Triacetate)								
Cable		Suitable for round cable φ6 to φ10 mm φ0.236 to φ0.394 in (Conductor cross section area: 0.25 to 0.75 mm <sup>2</sup> )								
Weight		Emitter: 70 g approx. Receiver: 85 g approx.	85 g approx.			Emitter: 75 g approx. Receiver: 95 g approx.	95 g approx.			

Note: Models which include 'T' are models with timer.

Refer to 'Sensor general catalog '03-'04 or SUNX website: <http://www.sunx.co.jp/> for details.