

## Multisensing Touch Manager

### FEATURES

- Qualified for Automotive Applications
- Low Supply Voltage Range: 1.8 V to 3.6 V
- Ultra-Low-Power Consumption
  - Active Mode: 270  $\mu$ A at 1 MHz, 2.2 V
  - Standby Mode: 0.7  $\mu$ A
  - Off Mode (RAM Retention): 0.1  $\mu$ A
- Ultra-Fast Wakeup From Standby Mode in Less Than 1  $\mu$ s
- 16-Bit RISC Architecture, 62.5-ns Instruction Cycle Time
- Basic Clock Module Configurations
  - Internal Frequencies up to 16 MHz With Four Calibrated Frequencies to  $\pm 1\%$
  - Internal Very-Low-Power Low-Frequency Oscillator
  - 32-kHz Crystal
  - High-Frequency (HF) Crystal up to 16 MHz
  - Resonator
  - External Digital Clock Source
  - External Resistor
- 16-Bit Timer\_A With Three Capture/Compare Registers
- 16-Bit Timer\_B With Three Capture/Compare Registers
- Universal Serial Communication Interface (USCI)
  - Enhanced UART With Auto-Baudrate Detection (LIN)
  - IrDA Encoder and Decoder
  - Synchronous SPI
  - I<sup>2</sup>C
- 10-Bit 200-ksp/s Analog-to-Digital Converter (ADC) With Internal Reference, Sample-and-Hold, Autoscan, and Data Transfer Controller

- Brownout Detector
- Serial Onboard Programming, No External Programming Voltage Needed, Programmable Code Protection by Security Fuse
- Bootstrap Loader (BSL)
- On-Chip Emulation Module
- Family Members Include:
  - NN325
    - 32KB + 256B Flash Memory
    - 1KB RAM
- Available in a 40-Pin QFN Package (RHA)
- For Complete Module Descriptions, See the *MSP430x2xx Family User's Guide (SLAU144)*

### APPLICATIONS

- Optical Touch Screen

### DESCRIPTION

The NN325 device is an ultra-low-power multisensing touch manager that includes optimized peripherals dedicated for high-performance touch-sensing applications. The device is optimized for ultra-low power operation using five low-power modes. The embedded powerful 16-bit RISC core based on a MSP430™ architecture offers 16-bit registers and constant generators to achieve maximum code efficiency. The digitally controlled oscillator (DCO) allows wakeup from low-power modes to active mode in less than 1  $\mu$ s. The ultra-low-power core comes together with two built-in 16-bit timers, a universal serial communication interface (USCI), a 10-bit ADC with integrated reference and data transfer controller (DTC), and 32 I/O pins.



Please be aware that an important notice concerning availability, standard warranty, and use in critical applications of Texas Instruments semiconductor products and disclaimers thereto appears at the end of this data sheet.

MSP430 is a trademark of Texas Instruments.

PRODUCTION DATA information is current as of publication date. Products conform to specifications per the terms of the Texas Instruments standard warranty. Production processing does not necessarily include testing of all parameters.

Copyright © 2013, Texas Instruments Incorporated

**Functional Block Diagram**

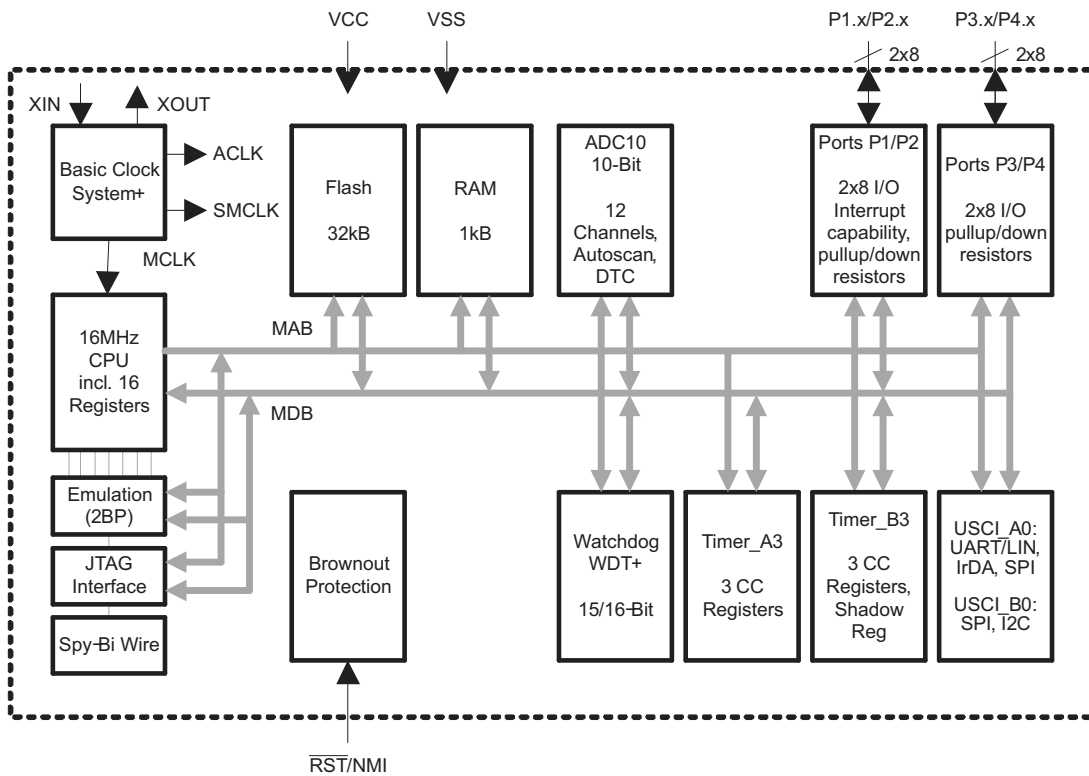



This integrated circuit can be damaged by ESD. Texas Instruments recommends that all integrated circuits be handled with appropriate precautions. Failure to observe proper handling and installation procedures can cause damage.

ESD damage can range from subtle performance degradation to complete device failure. Precision integrated circuits may be more susceptible to damage because very small parametric changes could cause the device not to meet its published specifications.

## Device Pinout

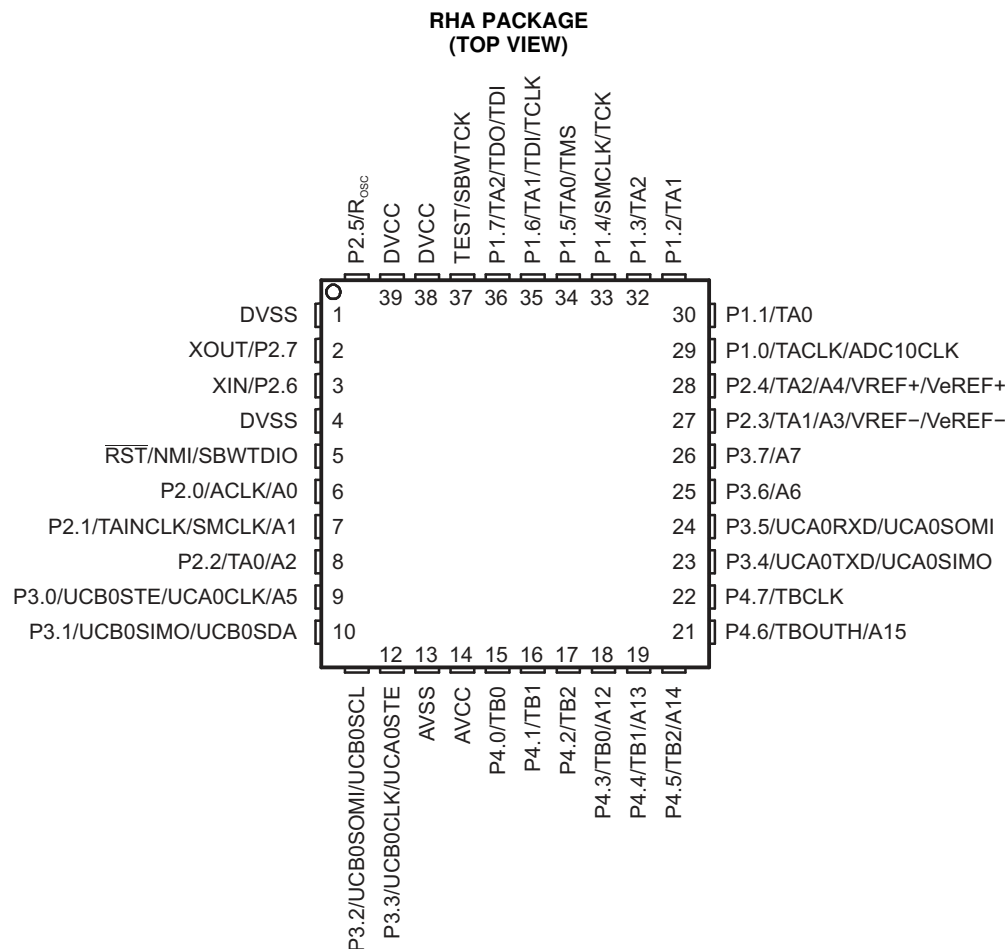

**Table 1. Terminal Functions**

TERMINAL		I/O	DESCRIPTION
NAME	NO. RHA		
P1.0/TACLK/ADC10CLK	29	I/O	General-purpose digital I/O pin Timer_A, clock signal TACLK input ADC10, conversion clock
P1.1/TA0	30	I/O	General-purpose digital I/O pin Timer_A, capture: CCI0A input, compare: OUT0 output BSL transmit
P1.2/TA1	31	I/O	General-purpose digital I/O pin Timer_A, capture: CCI1A input, compare: OUT1 output
P1.3/TA2	32	I/O	General-purpose digital I/O pin Timer_A, capture: CCI2A input, compare: OUT2 output
P1.4/SMCLK/TCK	33	I/O	General-purpose digital I/O pin SMCLK signal output Test Clock input for device programming and test
P1.5/TA0/TMS	34	I/O	General-purpose digital I/O pin Timer_A, compare: OUT0 output Test Mode Select input for device programming and test
P1.6/TA1/TDI/TCLK	35	I/O	General-purpose digital I/O pin Timer_A, compare: OUT1 output Test Data Input or Test Clock Input for programming and test
P1.7/TA2/TDO/TDI <sup>(1)</sup>	36	I/O	General-purpose digital I/O pin Timer_A, compare: OUT2 output Test Data Output or Test Data Input for programming and test
P2.0/ACLK/A0	6	I/O	General-purpose digital I/O pin ACLK output ADC10, analog input A0
P2.1/TAINCLK/SMCLK/A1	7	I/O	General-purpose digital I/O pin Timer_A, clock signal at INCLK SMCLK signal output ADC10, analog input A1
P2.2/TA0/A2	8	I/O	General-purpose digital I/O pin Timer_A, capture: CCI0B input, compare: OUT0 output BSL receive ADC10, analog input A2
P2.3/TA1/A3/ V <sub>REF-</sub> /V <sub>eREF-</sub>	27	I/O	General-purpose digital I/O pin Timer_A, capture CCI1B input, compare: OUT1 output ADC10, analog input A3 Negative reference voltage output/input
P2.4/TA2/A4/ V <sub>REF+</sub> /V <sub>eREF+</sub>	28	I/O	General-purpose digital I/O pin Timer_A, compare: OUT2 output ADC10, analog input A4 Positive reference voltage output/input

(1) TDO or TDI is selected via JTAG instruction.

**Table 1. Terminal Functions (continued)**

TERMINAL		I/O	DESCRIPTION
NAME	NO. RHA		
P2.5/R <sub>OSC</sub>	40	I/O	General-purpose digital I/O pin Input for external DCO resistor to define DCO frequency
XIN/P2.6	3	I/O	Input terminal of crystal oscillator General-purpose digital I/O pin
XOUT/P2.7	2	I/O	Output terminal of crystal oscillator General-purpose digital I/O pin <sup>(2)</sup>
P3.0/UCB0STE/UCA0CLK/A5	9	I/O	General-purpose digital I/O pin USCI_B0 slave transmit enable USCI_A0 clock input/output ADC10, analog input A5
P3.1/UCB0SIMO/UCB0SDA	10	I/O	General-purpose digital I/O pin USCI_B0 slave in, master out (SPI mode) USCI_B0 SDA I2C data (I2C mode)
P3.2/UCB0SOMI/UCB0SCL	11	I/O	General-purpose digital I/O pin USCI_B0 slave out, master in (SPI mode) USCI_B0 SCL I2C clock (I2C mode)
P3.3/UCB0CLK/UCA0STE	12	I/O	General-purpose digital I/O pin USCI_B0 clock input/output USCI_A0 slave transmit enable
P3.4/UCA0TXD/UCA0SIMO	23	I/O	General-purpose digital I/O pin USCI_A0 transmit data output (UART mode) USCI_A0 slave in, master out (SPI mode)
P3.5/UCA0RXD/UCA0SOMI	24	I/O	General-purpose digital I/O pin USCI_A0 receive data input in UART mode USCI_A0 slave out/master in SPI mode
P3.6/A6	25	I/O	General-purpose digital I/O pin ADC10 analog input A6
P3.7/A7	26	I/O	General-purpose digital I/O pin ADC10 analog input A7
P4.0/TB0	15	I/O	General-purpose digital I/O pin Timer_B, capture: CCI0A input, compare: OUT0 output
P4.1/TB1	16	I/O	General-purpose digital I/O pin Timer_B, capture: CCI1A input, compare: OUT1 output
P4.2/TB2	17	I/O	General-purpose digital I/O pin Timer_B, capture: CCI2A input, compare: OUT2 output
P4.3/TB0/A12	18	I/O	General-purpose digital I/O pin Timer_B, capture: CCI0B input, compare: OUT0 output ADC10 analog input A12
P4.4/TB1/A13	19	I/O	General-purpose digital I/O pin Timer_B, capture: CCI1B input, compare: OUT1 output ADC10 analog input A13

(2) If XOUT/P2.7 is used as an input, excess current flows until P2SEL.7 is cleared. This is due to the oscillator output driver connection to this pad after reset.

**Table 1. Terminal Functions (continued)**

TERMINAL		I/O	DESCRIPTION
NAME	NO. RHA		
P4.5/TB2/A14	20	I/O	General-purpose digital I/O pin Timer_B, compare: OUT2 output ADC10 analog input A14
P4.6/TBOUTH/A15	21	I/O	General-purpose digital I/O pin Timer_B, switch all TB0 to TB3 outputs to high impedance ADC10 analog input A15
P4.7/TBCLK	22	I/O	General-purpose digital I/O pin Timer_B, clock signal TBCLK input
$\overline{\text{RST}}/\text{NMI}/\text{SBWTDIO}$	5	I	Reset or nonmaskable interrupt input Spy-Bi-Wire test data input/output during programming and test
TEST/SBWTK	37	I	Selects test mode for JTAG pins on Port 1. The device protection fuse is connected to TEST. Spy-Bi-Wire test clock input during programming and test
DV <sub>CC</sub>	38, 39		Digital supply voltage
AV <sub>CC</sub>	14		Analog supply voltage
DV <sub>SS</sub>	1, 4		Digital ground reference
AV <sub>SS</sub>	13		Analog ground reference
QFN Pad	Pad	NA	QFN package pad; connection to DV <sub>SS</sub> recommended.

## Short-Form Description

### CPU

The MSP430™ CPU has a 16-bit RISC architecture that is highly transparent to the application. All operations, other than program-flow instructions, are performed as register operations in conjunction with seven addressing modes for source operand and four addressing modes for destination operand.

The CPU is integrated with 16 registers that provide reduced instruction execution time. The register-to-register operation execution time is one cycle of the CPU clock.

Four of the registers, R0 to R3, are dedicated as program counter, stack pointer, status register, and constant generator respectively. The remaining registers are general-purpose registers.

Peripherals are connected to the CPU using data, address, and control buses and can be handled with all instructions.

### Instruction Set

The instruction set consists of 51 instructions with three formats and seven address modes. Each instruction can operate on word and byte data. [Table 2](#) shows examples of the three types of instruction formats; [Table 3](#) shows the address modes.

Program Counter	PC/R0
Stack Pointer	SP/R1
Status Register	SR/CG1/R2
Constant Generator	CG2/R3
General-Purpose Register	R4
General-Purpose Register	R5
General-Purpose Register	R6
General-Purpose Register	R7
General-Purpose Register	R8
General-Purpose Register	R9
General-Purpose Register	R10
General-Purpose Register	R11
General-Purpose Register	R12
General-Purpose Register	R13
General-Purpose Register	R14
General-Purpose Register	R15

**Table 2. Instruction Word Formats**

INSTRUCTION FORMAT	EXAMPLE	OPERATION
Dual operands, source-destination	ADD R4,R5	R4 + R5 → R5
Single operands, destination only	CALL R8	PC → (TOS), R8 → PC
Relative jump, unconditional/conditional	JNE	Jump-on-equal bit = 0

**Table 3. Address Mode Descriptions**

ADDRESS MODE	S <sup>(1)</sup>	D <sup>(2)</sup>	SYNTAX	EXAMPLE	OPERATION
Register	✓	✓	MOV Rs,Rd	MOV R10,R11	R10 → R11
Indexed	✓	✓	MOV X(Rn),Y(Rm)	MOV 2(R5),6(R6)	M(2+R5) → M(6+R6)
Symbolic (PC relative)	✓	✓	MOV EDE,TONI		M(EDE) → M(TONI)
Absolute	✓	✓	MOV &MEM,&TCDAT		M(MEM) → M(TCDAT)
Indirect	✓		MOV @Rn,Y(Rm)	MOV @R10,Tab(R6)	M(R10) → M(Tab+R6)
Indirect autoincrement	✓		MOV @Rn+,Rm	MOV @R10+,R11	M(R10) → R11 R10 + 2 → R10
Immediate	✓		MOV #X,TONI	MOV #45,TONI	#45 → M(TONI)

(1) S = source

(2) D = destination

## Operating Modes

The NN325-Q1 has one active mode and five software-selectable low-power modes of operation. An interrupt event can wake up the device from any of the five low-power modes, service the request, and restore back to the low-power mode on return from the interrupt program.

The following six operating modes can be configured by software:

- Active mode (AM)
  - All clocks are active.
- Low-power mode 0 (LPM0)
  - CPU is disabled.
  - ACLK and SMCLK remain active. MCLK is disabled.
- Low-power mode 1 (LPM1)
  - CPU is disabled. ACLK and SMCLK remain active. MCLK is disabled.
  - DCO dc-generator is disabled if DCO not used in active mode.
- Low-power mode 2 (LPM2)
  - CPU is disabled.
  - MCLK and SMCLK are disabled.
  - DCO dc-generator remains enabled.
  - ACLK remains active.
- Low-power mode 3 (LPM3)
  - CPU is disabled.
  - MCLK and SMCLK are disabled.
  - DCO dc-generator is disabled.
  - ACLK remains active.
- Low-power mode 4 (LPM4)
  - CPU is disabled.
  - ACLK is disabled.
  - MCLK and SMCLK are disabled.
  - DCO dc-generator is disabled.
  - Crystal oscillator is stopped.



## Interrupt Vector Addresses

The interrupt vectors and the power-up starting address are located in the address range of 0FFFFh to 0FFC0h. The vector contains the 16-bit address of the appropriate interrupt handler instruction sequence.

If the reset vector (located at address 0FFFEh) contains 0FFFFh (for example, if flash is not programmed), the CPU goes into LPM4 immediately after power up.

**Table 4. Interrupt Vector Addresses**

INTERRUPT SOURCE	INTERRUPT FLAG	SYSTEM INTERRUPT	WORD ADDRESS	PRIORITY
Power-up External reset Watchdog Flash key violation PC out-of-range <sup>(1)</sup>	PORIFG RSTIFG WDTIFG KEYV <sup>(2)</sup>	Reset	0FFFEh	31, highest
NMI Oscillator fault Flash memory access violation	NMIIFG OFIFG ACCVIFG <sup>(2)(3)</sup>	(non)-maskable, (non)-maskable, (non)-maskable	0FFFCh	30
Timer_B3	TBCCR0 CCIFG <sup>(4)</sup>	maskable	0FFFAh	29
Timer_B3	TBCCR1 and TBCCR2 CCIFGs, TBIFG <sup>(2)(4)</sup>	maskable	0FFF8h	28
			0FFF6h	27
Watchdog Timer	WDTIFG	maskable	0FFF4h	26
Timer_A3	TACCR0 CCIFG (see Note 3)	maskable	0FFF2h	25
Timer_A3	TACCR1 CCIFG TACCR2 CCIFG TAIFG <sup>(2)(4)</sup>	maskable	0FFF0h	24
USCI_A0/USCI_B0 Receive	UCA0RXIFG, UCB0RXIFG <sup>(2)</sup>	maskable	0FFEEh	23
USCI_A0/USCI_B0 Transmit	UCA0TXIFG, UCB0TXIFG <sup>(2)</sup>	maskable	0FFECh	22
ADC10	ADC10IFG <sup>(4)</sup>	maskable	0FFEAh	21
			0FFE8h	20
I/O Port P2 (eight flags)	P2IFG.0 to P2IFG.7 <sup>(2)(4)</sup>	maskable	0FFE6h	19
I/O Port P1 (eight flags)	P1IFG.0 to P1IFG.7 <sup>(2)(4)</sup>	maskable	0FFE4h	18
			0FFE2h	17
			0FFE0h	16
<sup>(5)</sup>			0FFDEh	15
<sup>(6)</sup>			0FFDCh to 0FFC0h	14 to 0, lowest

- (1) A reset is generated if the CPU tries to fetch instructions from within the module register memory address range (0h to 01FFh) or from within unused address range.
- (2) Multiple source flags
- (3) (non)-maskable: the individual interrupt-enable bit can disable an interrupt event, but the general interrupt enable cannot. Nonmaskable: neither the individual nor the general interrupt-enable bit will disable an interrupt event.
- (4) Interrupt flags are located in the module.
- (5) This location is used as bootstrap loader security key (BSLSKEY). A 0AA55h at this location disables the BSL completely. A zero (0h) disables the erasure of the flash if an invalid password is supplied.
- (6) The interrupt vectors at addresses 0FFDCh to 0FFC0h are not used in this device and can be used for regular program code if necessary.

## Special Function Registers

Most interrupt and module enable bits are collected into the lowest address space. Special function register bits not allocated to a functional purpose are not physically present in the device. Simple software access is provided with this arrangement.

### Legend

rw	Bit can be read and written.
rw-0, 1	Bit can be read and written. It is Reset or Set by PUC.
rw-(0), (1)	Bit can be read and written. It is Reset or Set by POR.
<span style="background-color: #cccccc; display: inline-block; width: 1em; height: 1em;"></span>	SFR bit is not present in device.

**Table 5. Interrupt Enable 1**

Address	7	6	5	4	3	2	1	0
00h			ACCVIE	NMIIE			OFIE	WDTIE
			rw-0	rw-0			rw-0	rw-0

- WDTIE Watchdog timer interrupt enable. Inactive if watchdog mode is selected. Active if watchdog timer is configured in interval timer mode.
- OFIE Oscillator fault interrupt enable
- NMIIE (Non)maskable interrupt enable
- ACCVIE Flash access violation interrupt enable

**Table 6. Interrupt Enable 2**

Address	7	6	5	4	3	2	1	0
01h					UCB0TXIE	UCB0RXIE	UCA0TXIE	UCA0RXIE
					rw-0	rw-0	rw-0	rw-0

- UCA0RXIE USCI\_A0 receive-interrupt enable
- UCA0TXIE USCI\_A0 transmit-interrupt enable
- UCB0RXIE USCI\_B0 receive-interrupt enable
- UCB0TXIE USCI\_B0 transmit-interrupt enable

**Table 7. Interrupt Flag Register 1**

Address	7	6	5	4	3	2	1	0
02h				NMIIFG	RSTIFG	PORIFG	OFIFG	WDTIFG
				rw-0	rw-(0)	rw-(1)	rw-1	rw-(0)

- WDTIFG Set on watchdog timer overflow (in watchdog mode) or security key violation. Reset on V<sub>CC</sub> power-up or a reset condition at  $\overline{RST}/NMI$  pin in reset mode.
- OFIFG Flag set on oscillator fault
- RSTIFG External reset interrupt flag. Set on a reset condition at  $\overline{RST}/NMI$  pin in reset mode. Reset on V<sub>CC</sub> power up.
- PORIFG Power-on reset interrupt flag. Set on V<sub>CC</sub> power up.
- NMIIFG Set via  $\overline{RST}/NMI$  pin

**Table 8. Interrupt Flag Register 2**

Address	7	6	5	4	3	2	1	0
03h					UCB0TXIFG	UCB0RXIFG	UCA0TXIFG	UCA0RXIFG
					rw-1	rw-0	rw-1	rw-0

- UCA0RXIFG USCI\_A0 receive-interrupt flag
- UCA0TXIFG USCI\_A0 transmit-interrupt flag
- UCB0RXIFG USCI\_B0 receive-interrupt flag
- UCB0TXIFG USCI\_B0 transmit-interrupt flag

## Memory Organization

**Table 9. Memory Organization**

		<b>NN325</b>
Memory Main: interrupt vector Main: code memory	Size Flash Flash	32KB Flash 0FFFFh-0FFC0h 0FFFFh-08000h
Information memory	Size Flash	256 Byte 010FFh-01000h
Boot memory	Size ROM	1KB 0FFFh-0C00h
RAM	Size	1KB 05FFh-0200h
Peripherals	16-bit 8-bit 8-bit SFR	01FFh-0100h 0FFh-010h 0Fh-00h

### Bootstrap Loader (BSL)

The bootstrap loader (BSL) enables users to program the flash memory or RAM using a UART serial interface. Access to the NN325-Q1 memory via the BSL is protected by user-defined password. For complete description of the features of the BSL and its implementation, see the *MSP430 Programming Via the Bootstrap Loader User's Guide* (SLAU319).

**Table 10. BSL Function Pins**

<b>BSL FUNCTION</b>	<b>RHA PACKAGE PINS</b>
Data transmit	30 - P1.1
Data receive	8 - P2.2

### Flash Memory

The flash memory can be programmed via the JTAG port, the bootstrap loader, or in-system by the CPU. The CPU can perform single-byte and single-word writes to the flash memory. Features of the flash memory include:

- Flash memory has n segments of main memory and four segments of information memory (A to D) of 64 bytes each. Each segment in main memory is 512 bytes in size.
- Segments 0 to n may be erased in one step, or each segment may be individually erased.
- Segments A to D can be erased individually, or as a group with segments 0 to n. Segments A to D are also called *information memory*.
- Segment A contains calibration data. After reset, segment A is protected against programming and erasing. It can be unlocked, but care should be taken not to erase this segment if the device-specific calibration data is required.

## Peripherals

Peripherals are connected to the CPU through data, address, and control buses and can be handled using all instructions. For complete module descriptions, see the *MSP430x2xx Family User's Guide (SLAU144)*.

## Oscillator and System Clock

The clock system is supported by the basic clock module that includes support for a 32768-Hz watch crystal oscillator, an internal very-low-power low-frequency oscillator, an internal digitally-controlled oscillator (DCO), and a high-frequency crystal oscillator. The basic clock module is designed to meet the requirements of both low system cost and low power consumption. The internal DCO provides a fast turn-on clock source and stabilizes in less than 1  $\mu$ s. The basic clock module provides the following clock signals:

- Auxiliary clock (ACLK), sourced from a 32768-Hz watch crystal, a high-frequency crystal, or the internal very-low-power LF oscillator.
- Main clock (MCLK), the system clock used by the CPU.
- Sub-Main clock (SMCLK), the sub-system clock used by the peripheral modules.

**Table 11. DCO Calibration Data  
(Provided From Factory in Flash Information Memory Segment A)**

DCO FREQUENCY	CALIBRATION REGISTER	SIZE	ADDRESS
1 MHz	CALBC1_1MHZ	byte	010FFh
	CALDCO_1MHZ	byte	010FEh
8 MHz	CALBC1_8MHZ	byte	010FDh
	CALDCO_8MHZ	byte	010FCh
12 MHz	CALBC1_12MHZ	byte	010FBh
	CALDCO_12MHZ	byte	010FAh
16 MHz	CALBC1_16MHZ	byte	010F9h
	CALDCO_16MHZ	byte	010F8h

## Brownout

The brownout circuit is implemented to provide the proper internal reset signal to the device during power on and power off.

## Digital I/O

There are four 8-bit I/O ports implemented—ports P1, P2, P3, and P4:

- All individual I/O bits are independently programmable.
- Any combination of input, output, and interrupt condition is possible.
- Edge-selectable interrupt input capability for all eight bits of port P1 and P2.
- Read/write access to port-control registers is supported by all instructions.
- Each I/O has an individually programmable pullup/pulldown resistor.

Because there are only three I/O pins implemented from port P2, bits [5:1] of all port P2 registers read as 0, and write data is ignored.

## Watchdog Timer (WDT+)

The primary function of the WDT+ module is to perform a controlled system restart after a software problem occurs. If the selected time interval expires, a system reset is generated. If the watchdog function is not needed in an application, the module can be disabled or configured as an interval timer and can generate interrupts at selected time intervals.

## Timer\_A3

Timer\_A3 is a 16-bit timer/counter with three capture/compare registers. Timer\_A3 can support multiple capture/compares, PWM outputs, and interval timing. Timer\_A3 also has extensive interrupt capabilities. Interrupts may be generated from the counter on overflow conditions and from each of the capture/compare registers.

**Table 12. Timer\_A3 Signal Connections**

INPUT PIN NUMBER	DEVICE INPUT SIGNAL	MODULE INPUT NAME	MODULE BLOCK	MODULE OUTPUT SIGNAL	OUTPUT PIN NUMBER
RHA					RHA
29 - P1.0	TACLK	TACLK	Timer	NA	
	ACLK	ACLK			
	SMCLK	SMCLK			
7 - P2.1	TAINCLK	INCLK			
30 - P1.1	TA0	CCI0A	CCR0	TA0	30 - P1.1
8 - P2.2	TA0	CCI0B			8 - P2.2
	V <sub>SS</sub>	GND			34 - P1.5
	V <sub>CC</sub>	V <sub>CC</sub>			
31 - P1.2	TA1	CCI1A	CCR1	TA1	31 - P1.2
27 - P2.3	TA1	CCI1B			27 - P2.3
	V <sub>SS</sub>	GND			35 - P1.6
	V <sub>CC</sub>	V <sub>CC</sub>			
32 - P1.3	TA2	CCI2A	CCR2	TA2	32 - P1.3
	ACLK (internal)	CCI2B			28 - P2.4
	V <sub>SS</sub>	GND			36 - P1.7
	V <sub>CC</sub>	V <sub>CC</sub>			

### Timer\_B3

Timer\_B3 is a 16-bit timer/counter with three capture/compare registers. Timer\_B3 can support multiple capture/compares, PWM outputs, and interval timing. Timer\_B3 also has extensive interrupt capabilities. Interrupts may be generated from the counter on overflow conditions and from each of the capture/compare registers.

**Table 13. Timer\_B3 Signal Connections**

INPUT PIN NUMBER	DEVICE INPUT SIGNAL	MODULE INPUT NAME	MODULE BLOCK	MODULE OUTPUT SIGNAL	OUTPUT PIN NUMBER
RHA					RHA
22 - P4.7	TBCLK	TBCLK	Timer	NA	
	ACLK	ACLK			
	SMCLK	SMCLK			
22 - P4.7	TBCLK	INCLK			
15 - P4.0	TB0	CCI0A	CCR0	TB0	15 - P4.0
18 - P4.3	TB0	CCI0B			18 - P4.3
	V <sub>SS</sub>	GND			
	V <sub>CC</sub>	V <sub>CC</sub>			
16 - P4.1	TB1	CCI1A	CCR1	TB1	16 - P4.1
19 - P4.4	TB1	CCI1B			19 - P4.4
	V <sub>SS</sub>	GND			
	V <sub>CC</sub>	V <sub>CC</sub>			
17 - P4.2	TB2	CCI2A	CCR2	TB2	17 - P4.2
	ACLK (internal)	CCI2B			20 - P4.5
	V <sub>SS</sub>	GND			
	V <sub>CC</sub>	V <sub>CC</sub>			

### Universal Serial Communications Interface (USCI)

The USCI module is used for serial data communication. The USCI module supports synchronous communication protocols like SPI (3 or 4 pin), I2C and asynchronous communication protocols such as UART, enhanced UART with automatic baudrate detection (LIN), and IrDA.

USCI\_A0 provides support for SPI (3 or 4 pin), UART, enhanced UART, and IrDA.

USCI\_B0 provides support for SPI (3 or 4 pin) and I2C.

### ADC10

The ADC10 module supports fast, 10-bit analog-to-digital conversions. The module implements a 10-bit SAR core, sample select control, reference generator and data transfer controller, or DTC, for automatic conversion result handling allowing ADC samples to be converted and stored without any CPU intervention.

**Peripheral File Map**
**Table 14. Peripherals With Word Access**

MODULE	REGISTER NAME	SHORT NAME	ADDRESS OFFSET
<b>ADC10</b>	ADC data transfer start address	ADC10SA	1BCh
	ADC memory	ADC10MEM	1B4h
	ADC control register 1	ADC10CTL1	1B2h
	ADC control register 0	ADC10CTL0	1B0h
	ADC analog enable 0	ADC10AE0	04Ah
	ADC analog enable 1	ADC10AE1	04Bh
	ADC data transfer control register 1	ADC10DTC1	049h
	ADC data transfer control register 0	ADC10DTC0	048h
<b>Timer_B</b>	Capture/compare register	TBCCR2	0196h
	Capture/compare register	TBCCR1	0194h
	Capture/compare register	TBCCR0	0192h
	Timer_B register	TBR	0190h
	Capture/compare control	TBCCTL2	0186h
	Capture/compare control	TBCCTL1	0184h
	Capture/compare control	TBCCTL0	0182h
	Timer_B control	TBCTL	0180h
	Timer_B interrupt vector	TBIV	011Eh
<b>Timer_A</b>	Capture/compare register	TACCR2	0176h
	Capture/compare register	TACCR1	0174h
	Capture/compare register	TACCR0	0172h
	Timer_A register	TAR	0170h
	Capture/compare control	TACCTL2	0166h
	Capture/compare control	TACCTL1	0164h
	Capture/compare control	TACCTL0	0162h
	Timer_A control	TACTL	0160h
	Timer_A interrupt vector	TAIV	012Eh
<b>Flash Memory</b>	Flash control 3	FCTL3	012Ch
	Flash control 2	FCTL2	012Ah
	Flash control 1	FCTL1	0128h
<b>Watchdog Timer+</b>	Watchdog/timer control	WDTCTL	0120h

**Table 15. Peripherals With Byte Access**

MODULE	REGISTER NAME	SHORT NAME	ADDRESS OFFSET
<b>USCI_B0</b>	USCI_B0 transmit buffer	UCB0TXBUF	06Fh
	USCI_B0 receive buffer	UCB0RXBUF	06Eh
	USCI_B0 status	UCB0STAT	06Dh
	USCI_B0 bit rate control 1	UCB0BR1	06Bh
	USCI_B0 bit rate control 0	UCB0BR0	06Ah
	USCI_B0 control 1	UCB0CTL1	069h
	USCI_B0 control 0	UCB0CTL0	068h
	USCI_B0 I2C slave address	UCB0SA	011Ah
	USCI_B0 I2C own address	UCB0OA	0118h
<b>USCI_A0</b>	USCI_A0 transmit buffer	UCA0TXBUF	067h
	USCI_A0 receive buffer	UCA0RXBUF	066h
	USCI_A0 status	UCA0STAT	065h
	USCI_A0 modulation control	UCA0MCTL	064h
	USCI_A0 baud rate control 1	UCA0BR1	063h
	USCI_A0 baud rate control 0	UCA0BR0	062h
	USCI_A0 control 1	UCA0CTL1	061h
	USCI_A0 control 0	UCA0CTL0	060h
	USCI_A0 IrDA receive control	UCA0IRRCTL	05Fh
	USCI_A0 IrDA transmit control	UCA0IRTCTL	05Eh
	USCI_A0 auto baud rate control	UCA0ABCTL	05Dh
	<b>Basic Clock System+</b>	Basic clock system control 3	BCSCTL3
Basic clock system control 2		BCSCTL2	058h
Basic clock system control 1		BCSCTL1	057h
DCO clock frequency control		DCOCTL	056h
<b>Port P4</b>	Port P4 resistor enable	P4REN	011h
	Port P4 selection	P4SEL	01Fh
	Port P4 direction	P4DIR	01Eh
	Port P4 output	P4OUT	01Dh
	Port P4 input	P4IN	01Ch
<b>Port P3</b>	Port P3 resistor enable	P3REN	010h
	Port P3 selection	P3SEL	01Bh
	Port P3 direction	P3DIR	01Ah
	Port P3 output	P3OUT	019h
	Port P3 input	P3IN	018h
<b>Port P2</b>	Port P2 resistor enable	P2REN	02Fh
	Port P2 selection	P2SEL	02Eh
	Port P2 interrupt enable	P2IE	02Dh
	Port P2 interrupt edge select	P2IES	02Ch
	Port P2 interrupt flag	P2IFG	02Bh
	Port P2 direction	P2DIR	02Ah
	Port P2 output	P2OUT	029h
	Port P2 input	P2IN	028h



**Table 15. Peripherals With Byte Access (continued)**

MODULE	REGISTER NAME	SHORT NAME	ADDRESS OFFSET
<b>Port P1</b>	Port P1 resistor enable	P1REN	027h
	Port P1 selection	P1SEL	026h
	Port P1 interrupt enable	P1IE	025h
	Port P1 interrupt edge select	P1IES	024h
	Port P1 interrupt flag	P1IFG	023h
	Port P1 direction	P1DIR	022h
	Port P1 output	P1OUT	021h
	Port P1 input	P1IN	020h
<b>Special Function</b>	SFR interrupt flag 2	IFG2	003h
	SFR interrupt flag 1	IFG1	002h
	SFR interrupt enable 2	IE2	001h
	SFR interrupt enable 1	IE1	000h

**Absolute Maximum Ratings<sup>(1)</sup>**

Voltage applied at V <sub>CC</sub> to V <sub>SS</sub>	-0.3 V to 4.1 V	
Voltage applied to any pin <sup>(2)</sup>	-0.3 V to V <sub>CC</sub> + 0.3 V	
Diode current at any device terminal	±2 mA	
Storage temperature, T <sub>stg</sub> <sup>(3)</sup>	Unprogrammed device	-55°C to 150°C
	Programmed device	-55°C to 150°C

- (1) Stresses beyond those listed under *absolute maximum ratings* may cause permanent damage to the device. These are stress ratings only, and functional operation of the device at these or any other conditions beyond those indicated under *recommended operating conditions* is not implied. Exposure to absolute-maximum-rated conditions for extended periods may affect device reliability.
- (2) All voltages referenced to V<sub>SS</sub>. The JTAG fuse-blow voltage, V<sub>FB</sub>, is allowed to exceed the absolute maximum rating. The voltage is applied to the TEST pin when blowing the JTAG fuse.
- (3) Higher temperature may be applied during board soldering process according to the current JEDEC J-STD-020 specification with peak reflow temperatures not higher than classified on the device label on the shipping boxes or reels.

**Recommended Operating Conditions<sup>(1)(2)</sup>**

			MIN	NOM	MAX	UNIT
V <sub>CC</sub>	Supply voltage	AV <sub>CC</sub> = DV <sub>CC</sub> = V <sub>CC</sub>	During program execution	1.8	3.6	V
			During program/erase flash memory	2.2	3.6	V
V <sub>SS</sub>	Supply voltage	AV <sub>SS</sub> = DV <sub>SS</sub> = V <sub>SS</sub>		0		V
T <sub>A</sub>	Operating free-air temperature	T version	-40		105	°C
f <sub>SYSTEM</sub>	Processor frequency (maximum MCLK frequency) <sup>(1)(2)</sup> (see Figure 1)	V <sub>CC</sub> = 1.8 V, Duty cycle = 50% ±10%	dc		4.15	MHz
		V <sub>CC</sub> = 2.7 V, Duty cycle = 50% ±10%	dc		12	
		V <sub>CC</sub> ≥ 3.3 V, Duty cycle = 50% ±10%	dc		16	

- (1) The CPU is clocked directly with MCLK. Both the high and low phase of MCLK must not exceed the pulse width of the specified maximum frequency.
- (2) Modules might have a different maximum input clock specification. See the specification of the respective module in this data sheet.

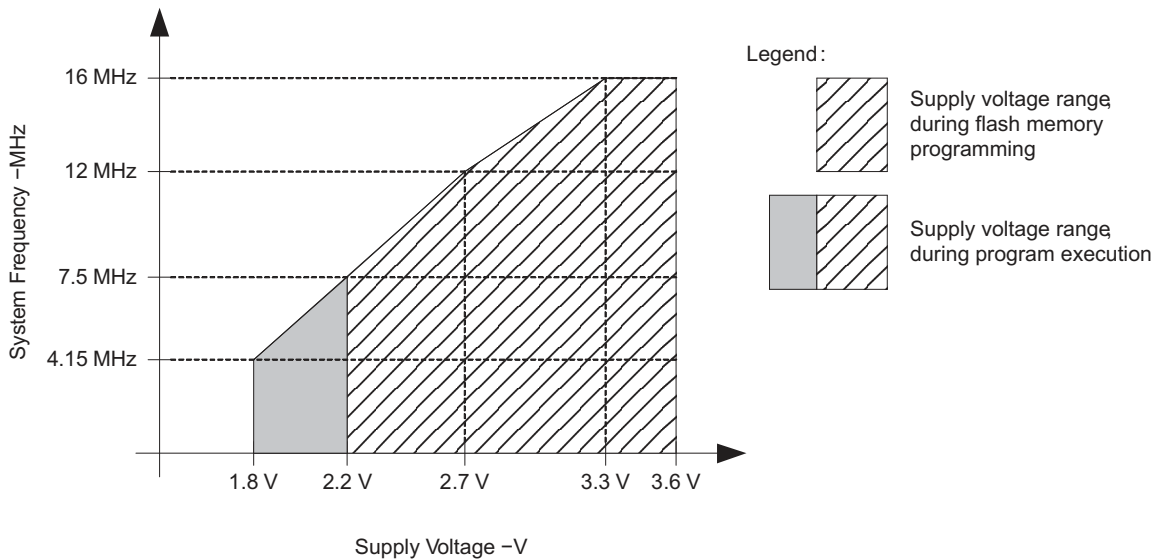

NOTE: Minimum processor frequency is defined by system clock. Flash program or erase operations require a minimum V<sub>CC</sub> of 2.2 V.

**Figure 1. Operating Area**

**Active Mode Supply Current (into  $DV_{CC} + AV_{CC}$ ) Excluding External Current <sup>(1)(2)</sup>**

over recommended ranges of supply voltage and operating free-air temperature (unless otherwise noted)

PARAMETER	TEST CONDITIONS	$T_A$	$V_{CC}$	MIN	TYP	MAX	UNIT
$I_{AM,1MHz}$ Active mode (AM) current (1 MHz)	$f_{DCO} = f_{MCLK} = f_{SMCLK} = 1$ MHz, $f_{ACLK} = 32768$ Hz, Program executes in flash, BCSCTL1 = CALBC1_1MHZ, DCOCTL = CALDCO_1MHZ, CPUOFF = 0, SCG0 = 0, SCG1 = 0, OSCOFF = 0		2.2 V		270	390	$\mu A$
			3 V		390	550	
$I_{AM,1MHz}$ Active mode (AM) current (1 MHz)	$f_{DCO} = f_{MCLK} = f_{SMCLK} = 1$ MHz, $f_{ACLK} = 32768$ Hz, Program executes in RAM, BCSCTL1 = CALBC1_1MHZ, DCOCTL = CALDCO_1MHZ, CPUOFF = 0, SCG0 = 0, SCG1 = 0, OSCOFF = 0		2.2 V		240		$\mu A$
			3.3 V		340		
$I_{AM,4kHz}$ Active mode (AM) current (4 kHz)	$f_{MCLK} = f_{SMCLK} = f_{ACLK} = 32768$ Hz/8 = 4096 Hz, $f_{DCO} = 0$ Hz, Program executes in flash, SELMx = 11, SELS = 1, DIVMx = DIVSx = DIVAx = 11, CPUOFF = 0, SCG0 = 1, SCG1 = 0, OSCOFF = 0	-40°C to 85°C	2.2 V		5	9	$\mu A$
				105°C			
		-40°C to 85°C	3 V		6	10	
				105°C			
$I_{AM,100kHz}$ Active mode (AM) current (100 kHz)	$f_{MCLK} = f_{SMCLK} = f_{DCO(0, 0)} \approx 100$ kHz, $f_{ACLK} = 0$ Hz, Program executes in flash, RSELX = 0, DCOx = 0, CPUOFF = 0, SCG0 = 0, SCG1 = 0, OSCOFF = 1	-40°C to 85°C	2.2 V		60	85	$\mu A$
				105°C			
		-40°C to 85°C	3 V		72	95	
				105°C			

 (1) All inputs are tied to 0 V or  $V_{CC}$ . Outputs do not source or sink any current.

(2) The currents are characterized with a Micro Crystal CC4V-T1A SMD crystal with a load capacitance of 9 pF. The internal and external load capacitance is chosen to closely match the required 9 pF.

**Typical Characteristics - Active-Mode Supply Current (Into  $DV_{CC} + AV_{CC}$ )**

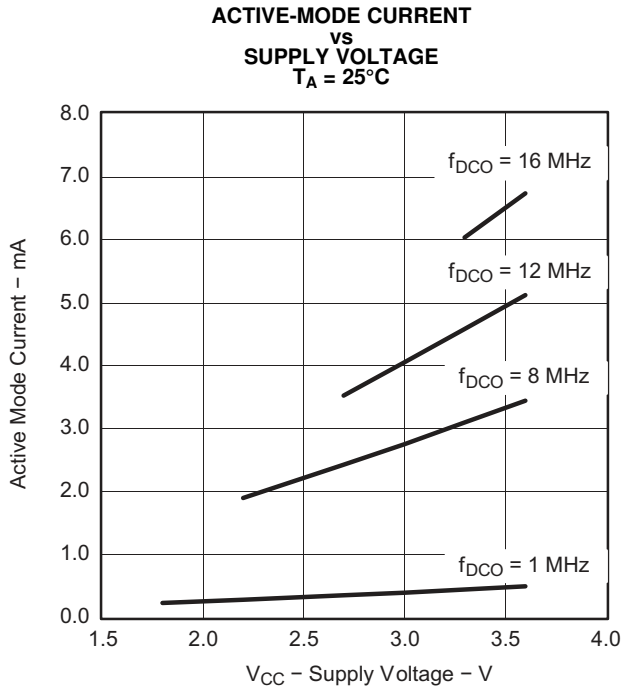

**Figure 2.**

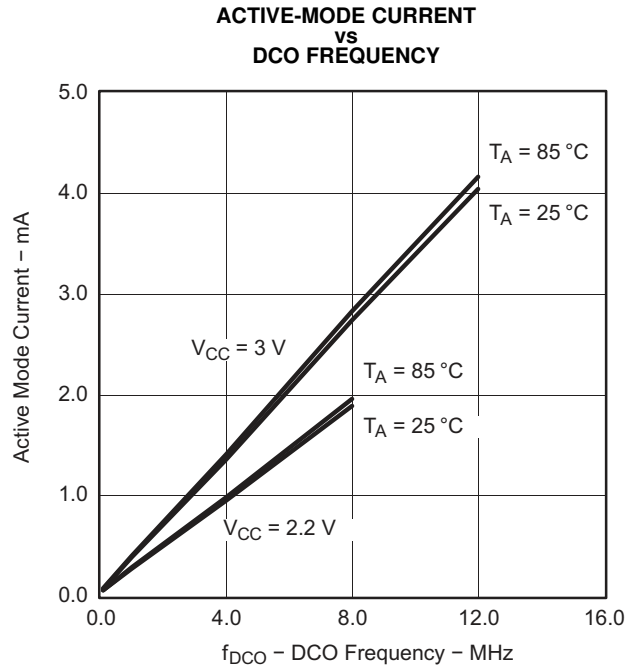

**Figure 3.**

**Low-Power-Mode Supply Currents (Into  $V_{CC}$ ) Excluding External Current** <sup>(1)(2)</sup>

over recommended ranges of supply voltage and operating free-air temperature (unless otherwise noted)

PARAMETER	TEST CONDITIONS	$T_A$	$V_{CC}$	MIN	TYP	MAX	UNIT	
$I_{LPM0,1MHz}$	Low-power mode 0 (LPM0) current <sup>(3)</sup>		2.2 V		75	90	$\mu A$	
			3 V		90	120		
$I_{LPM0,100kHz}$	Low-power mode 0 (LPM0) current <sup>(3)</sup>		2.2 V		37	48	$\mu A$	
			3 V		41	65		
$I_{LPM2}$	Low-power mode 2 (LPM2) current <sup>(4)</sup>		2.2 V	-40°C to 85°C		22	29	$\mu A$
				105°C			31	
			3 V	-40°C to 85°C		25	32	
				105°C			34	
$I_{LPM3,LFXT1}$	Low-power mode 3 (LPM3) current <sup>(4)</sup>		2.2 V	-40°C		0.7	1.4	$\mu A$
				25°C		0.7	1.4	
				85°C		2.4	3.3	
				105°C		5	10	
			3 V	-40°C		0.9	1.5	
				25°C		0.9	1.5	
				85°C		2.6	3.8	
				105°C		6	12	
$I_{LPM3,VLO}$	Low-power mode 3 current, (LPM3) <sup>(4)</sup>		2.2 V	-40°C		0.4	1	$\mu A$
				25°C		0.5	1	
				85°C		1.8	2.9	
				105°C		4.5	9	
			3 V	-40°C		0.5	1.2	
				25°C		0.6	1.2	
				85°C		2.1	3.3	
				105°C		5.5	11	
$I_{LPM4}$	Low-power mode 4 (LPM4) current <sup>(5)</sup>		2.2 V	-40°C		0.1	0.5	$\mu A$
				25°C		0.1	0.5	
			3 V	85°C		1.5	3	
				105°C		4.5	9	

 (1) All inputs are tied to 0 V or  $V_{CC}$ . Outputs do not source or sink any current.

(2) The currents are characterized with a Micro Crystal CC4V-T1A SMD crystal with a load capacitance of 9 pF. The internal and external load capacitance is chosen to closely match the required 9 pF.

(3) Current for brownout and WDT clocked by SMCLK included.

(4) Current for brownout and WDT clocked by ACLK included.

(5) Current for brownout included.

### Schmitt-Trigger Inputs (Ports P1, P2, P3, P4, and $\overline{\text{RST/NMI}}$ )

over recommended ranges of supply voltage and operating free-air temperature (unless otherwise noted)

PARAMETER	TEST CONDITIONS	V <sub>CC</sub>	MIN	TYP	MAX	UNIT
V <sub>IT+</sub> Positive-going input threshold voltage			0.45 V <sub>CC</sub>		0.75 V <sub>CC</sub>	V
		2.2 V	1		1.65	
		3 V	1.35		2.25	
V <sub>IT-</sub> Negative-going input threshold voltage			0.25 V <sub>CC</sub>		0.55 V <sub>CC</sub>	V
		2.2 V	0.55		1.20	
		3 V	0.75		1.65	
V <sub>hys</sub> Input voltage hysteresis (V <sub>IT+</sub> - V <sub>IT-</sub> )		2.2 V	0.1		1	V
		3 V	0.3		1	
R <sub>Pull</sub> Pullup/pulldown resistor	For pullup: V <sub>IN</sub> = V <sub>SS</sub> , For pulldown: V <sub>IN</sub> = V <sub>CC</sub>	3 V	20	35	50	kΩ
C <sub>I</sub> Input capacitance	V <sub>IN</sub> = V <sub>SS</sub> or V <sub>CC</sub>			5		pF

### Inputs (Ports P1, P2)

over recommended ranges of supply voltage and operating free-air temperature (unless otherwise noted)

PARAMETER	TEST CONDITIONS	V <sub>CC</sub>	MIN	TYP	MAX	UNIT
t <sub>(int)</sub> External interrupt timing	Port P1, P2: P1.x to P2.x, External trigger pulse width to set interrupt flag <sup>(1)</sup>	2.2 V, 3 V	20			ns

(1) An external signal sets the interrupt flag every time the minimum interrupt pulse width t<sub>(int)</sub> is met. It may be set even with trigger signals shorter than t<sub>(int)</sub>.

### Leakage Current (Ports P1, P2, P3, and P4)

over recommended ranges of supply voltage and operating free-air temperature (unless otherwise noted)

PARAMETER	TEST CONDITIONS	V <sub>CC</sub>	MIN	TYP	MAX	UNIT
I <sub>lkg(Px.y)</sub> High-impedance leakage current	(1) (2)	2.2 V, 3 V			±50	nA

(1) The leakage current is measured with V<sub>SS</sub> or V<sub>CC</sub> applied to the corresponding pin(s), unless otherwise noted.

(2) The leakage of the digital port pins is measured individually. The port pin is selected for input and the pullup/pulldown resistor is disabled.

## Outputs (Ports P1, P2, P3, and P4)

over recommended ranges of supply voltage and operating free-air temperature (unless otherwise noted)

PARAMETER		TEST CONDITIONS	V <sub>CC</sub>	MIN	MAX	UNIT
V <sub>OH</sub>	High-level output voltage	I <sub>OH(max)</sub> = -1.5 mA <sup>(1)</sup>	2.2 V	V <sub>CC</sub> - 0.25	V <sub>CC</sub>	V
		I <sub>OH(max)</sub> = -6 mA <sup>(2)</sup>		V <sub>CC</sub> - 0.6	V <sub>CC</sub>	
		I <sub>OH(max)</sub> = -1.5 mA <sup>(1)</sup>	3 V	V <sub>CC</sub> - 0.25	V <sub>CC</sub>	
		I <sub>OH(max)</sub> = -6 mA <sup>(2)</sup>		V <sub>CC</sub> - 0.6	V <sub>CC</sub>	
V <sub>OL</sub>	Low-level output voltage	I <sub>OL(max)</sub> = 1.5 mA <sup>(1)</sup>	2.2 V	V <sub>SS</sub>	V <sub>SS</sub> + 0.25	V
		I <sub>OL(max)</sub> = 6 mA <sup>(2)</sup>		V <sub>SS</sub>	V <sub>SS</sub> + 0.6	
		I <sub>OL(max)</sub> = 1.5 mA <sup>(1)</sup>	3 V	V <sub>SS</sub>	V <sub>SS</sub> + 0.25	
		I <sub>OL(max)</sub> = 6 mA <sup>(2)</sup>		V <sub>SS</sub>	V <sub>SS</sub> + 0.6	

(1) The maximum total current, I<sub>OH(max)</sub> and I<sub>OL(max)</sub>, for all outputs combined, should not exceed ±12 mA to hold the maximum voltage drop specified.

(2) The maximum total current, I<sub>OH(max)</sub> and I<sub>OL(max)</sub>, for all outputs combined, should not exceed ±48 mA to hold the maximum voltage drop specified.

## Output Frequency (Ports P1, P2, P3, and P4)

over recommended ranges of supply voltage and operating free-air temperature (unless otherwise noted)

PARAMETER		TEST CONDITIONS	V <sub>CC</sub>	MIN	TYP	MAX	UNIT
f <sub>Px,y</sub>	Port output frequency (with load)	P1.4/SMCLK, C <sub>L</sub> = 20 pF R <sub>L</sub> = 1 kΩ against V <sub>CC</sub> /2 <sup>(1)(2)</sup>	2.2 V			10	MHz
			3 V			12	
f <sub>Port_CLK</sub>	Clock output frequency	P2.0/ACLK, P1.4/SMCLK, C <sub>L</sub> = 20 pF <sup>(2)</sup>	2.2 V			12	MHz
			3 V			16	

(1) Alternatively, a resistive divider with two 2-kΩ resistors between V<sub>CC</sub> and V<sub>SS</sub> is used as load. The output is connected to the center tap of the divider.

(2) The output voltage reaches at least 10% and 90% V<sub>CC</sub> at the specified toggle frequency.

### Typical Characteristics - Outputs

One output loaded at a time.

**TYPICAL LOW-LEVEL OUTPUT CURRENT**  
vs  
**LOW-LEVEL OUTPUT VOLTAGE**

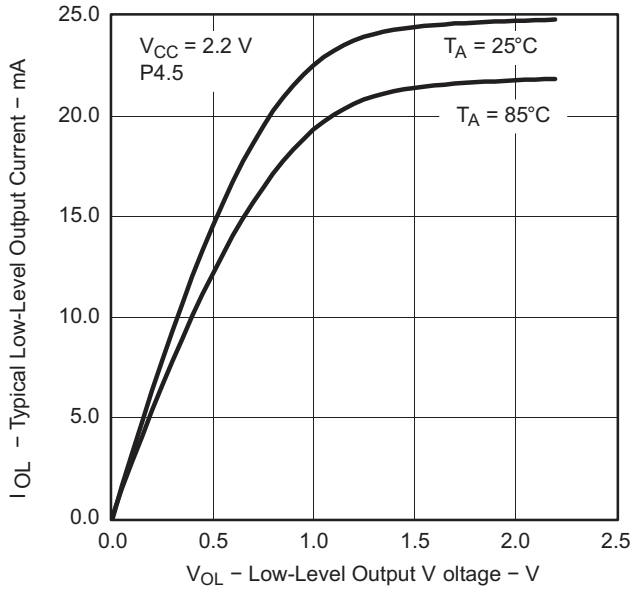

Figure 4.

**TYPICAL LOW-LEVEL OUTPUT CURRENT**  
vs  
**LOW-LEVEL OUTPUT VOLTAGE**

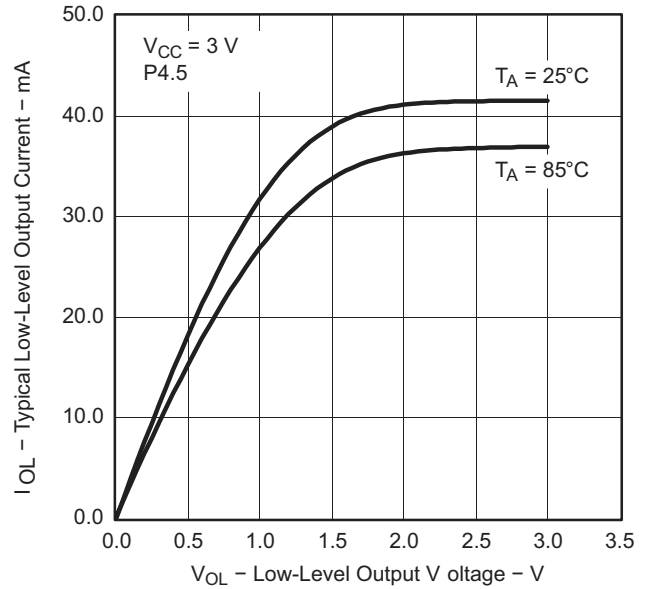

Figure 5.

**TYPICAL HIGH-LEVEL OUTPUT CURRENT**  
vs  
**HIGH-LEVEL OUTPUT VOLTAGE**

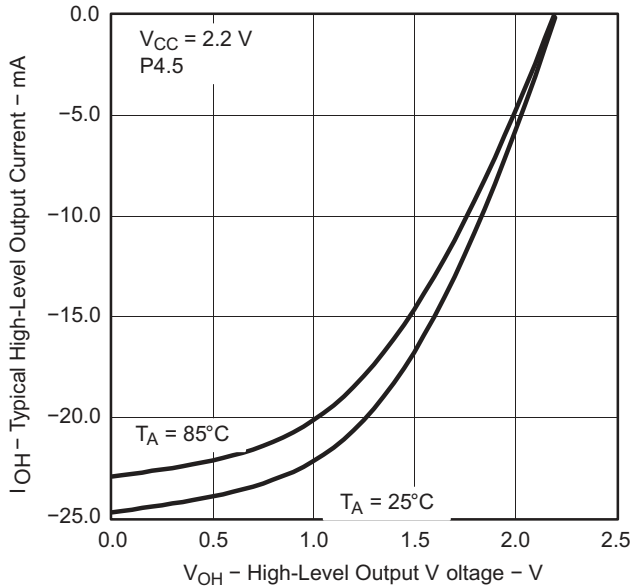

Figure 6.

**TYPICAL HIGH-LEVEL OUTPUT CURRENT**  
vs  
**HIGH-LEVEL OUTPUT VOLTAGE**

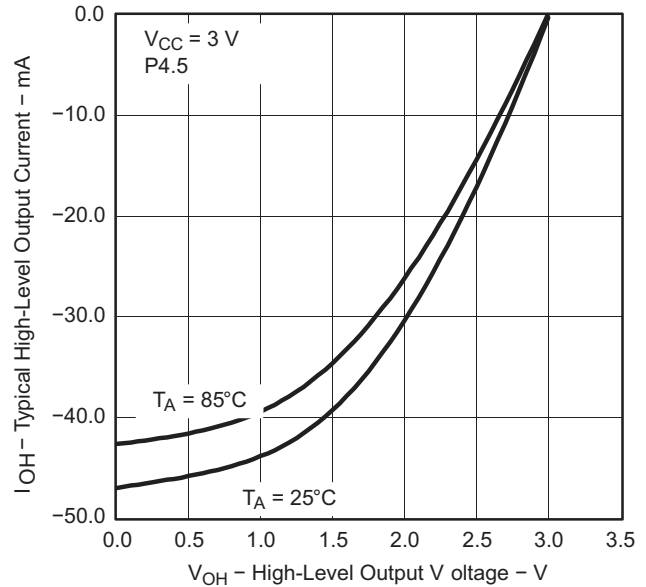

Figure 7.



### POR/Brownout Reset (BOR) <sup>(1)</sup> <sup>(2)</sup>

over recommended ranges of supply voltage and operating free-air temperature (unless otherwise noted)

PARAMETER	TEST CONDITIONS	V <sub>CC</sub>	MIN	TYP	MAX	UNIT
V <sub>CC(start)</sub>	See Figure 8	dV <sub>CC</sub> /dt ≤ 3 V/s		0.7 × V <sub>(B_IT-)</sub>		V
V <sub>(B_IT-)</sub>	See Figure 8 through Figure 10	dV <sub>CC</sub> /dt ≤ 3 V/s			1.71	V
V <sub>hys(B_IT-)</sub>	See Figure 8	dV <sub>CC</sub> /dt ≤ 3 V/s	70	130	210	mV
t <sub>d(BOR)</sub>	See Figure 8				2000	μs
t <sub>(reset)</sub>	Pulse length needed at $\overline{\text{RST}}/\text{NMI}$ pin to accepted reset internally	3 V	2			μs

- (1) The current consumption of the brownout module is already included in the I<sub>CC</sub> current consumption data. The voltage level V<sub>(B\_IT-)</sub> + V<sub>hys(B\_IT-)</sub> is ≤ 1.8 V.
- (2) During power up, the CPU begins code execution following a period of t<sub>d(BOR)</sub> after V<sub>CC</sub> = V<sub>(B\_IT-)</sub> + V<sub>hys(B\_IT-)</sub>. The default DCO settings must not be changed until V<sub>CC</sub> ≥ V<sub>CC(min)</sub>, where V<sub>CC(min)</sub> is the minimum supply voltage for the desired operating frequency.

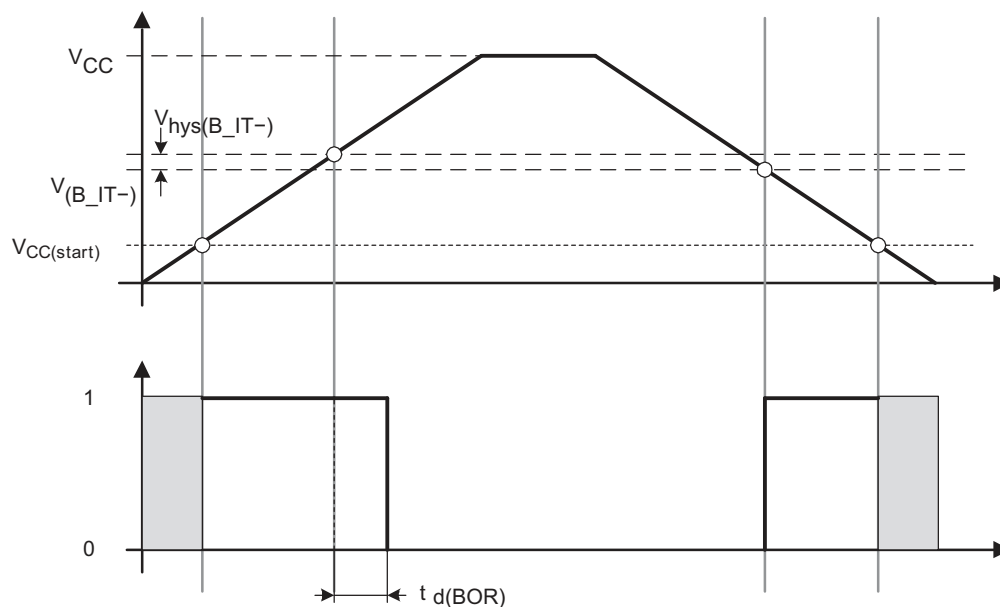

Figure 8. POR/Brownout Reset (BOR) vs Supply Voltage

Typical Characteristics - POR/Brownout Reset (BOR)

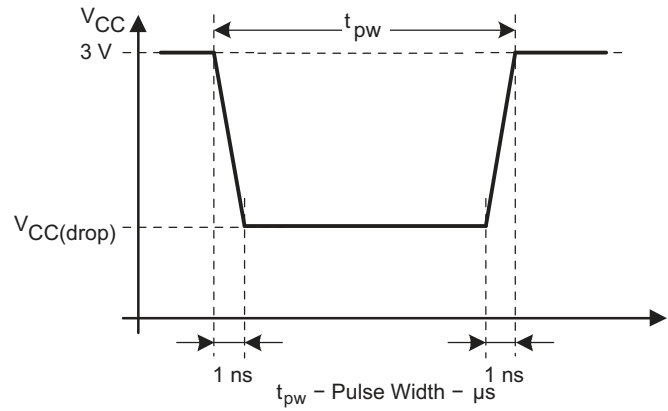
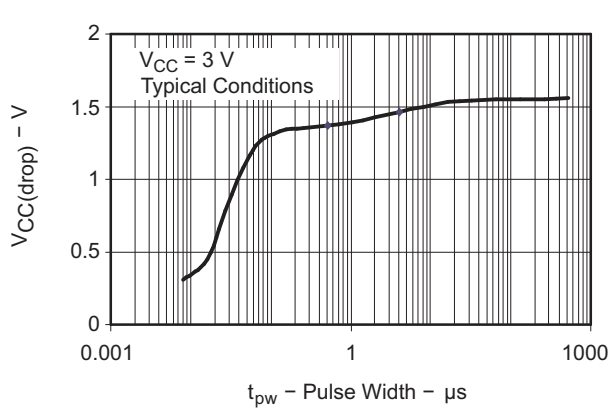

Figure 9.  $V_{CC}(\text{drop})$  Level With a Square Voltage Drop to Generate a POR/Brownout Signal

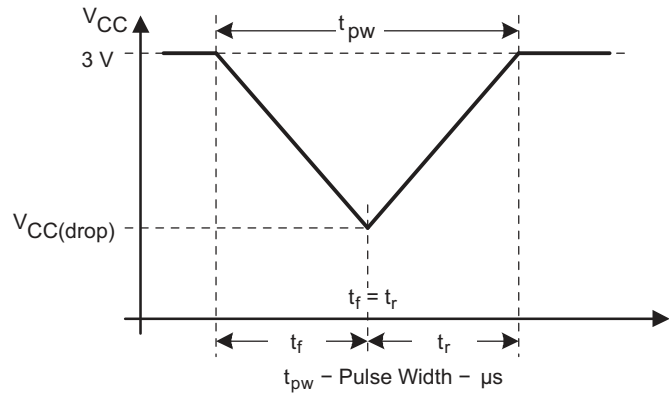
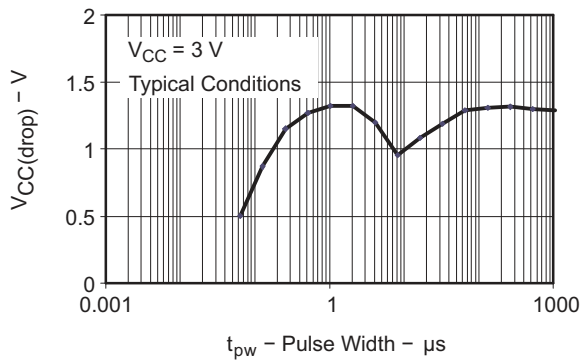

Figure 10.  $V_{CC}(\text{drop})$  Level With a Triangle Voltage Drop to Generate a POR/Brownout Signal

## Main DCO Characteristics

- All ranges selected by RSELx overlap with RSELx + 1: RSELx = 0 overlaps RSELx = 1, ... RSELx = 14 overlaps RSELx = 15.
- DCO control bits DCOx have a step size as defined by parameter S<sub>DCO</sub>.
- Modulation control bits MODx select how often f<sub>DCO(RSEL,DCO+1)</sub> is used within the period of 32 DCOCLK cycles. The frequency f<sub>DCO(RSEL,DCO)</sub> is used for the remaining cycles. The frequency is an average equal to:

$$f_{\text{average}} = \frac{32 \times f_{\text{DCO(RSEL,DCO)}} \times f_{\text{DCO(RSEL,DCO+1)}}}{\text{MOD} \times f_{\text{DCO(RSEL,DCO)}} + (32 - \text{MOD}) \times f_{\text{DCO(RSEL,DCO+1)}}}$$

## DCO Frequency

over recommended ranges of supply voltage and operating free-air temperature (unless otherwise noted)

PARAMETER		TEST CONDITIONS	V <sub>CC</sub>	MIN	TYP	MAX	UNIT
V <sub>CC</sub>	Supply voltage range	RSELx < 14		1.8		3.6	V
		RSELx = 14		2.2		3.6	
		RSELx = 15		3.0		3.6	
f <sub>DCO(0,0)</sub>	DCO frequency (0, 0)	RSELx = 0, DCOx = 0, MODx = 0	2.2 V, 3 V	0.06		0.14	MHz
f <sub>DCO(0,3)</sub>	DCO frequency (0, 3)	RSELx = 0, DCOx = 3, MODx = 0	2.2 V, 3 V	0.07		0.17	MHz
f <sub>DCO(1,3)</sub>	DCO frequency (1, 3)	RSELx = 1, DCOx = 3, MODx = 0	2.2 V, 3 V	0.10		0.20	MHz
f <sub>DCO(2,3)</sub>	DCO frequency (2, 3)	RSELx = 2, DCOx = 3, MODx = 0	2.2 V, 3 V	0.14		0.28	MHz
f <sub>DCO(3,3)</sub>	DCO frequency (3, 3)	RSELx = 3, DCOx = 3, MODx = 0	2.2 V, 3 V	0.20		0.40	MHz
f <sub>DCO(4,3)</sub>	DCO frequency (4, 3)	RSELx = 4, DCOx = 3, MODx = 0	2.2 V, 3 V	0.28		0.54	MHz
f <sub>DCO(5,3)</sub>	DCO frequency (5, 3)	RSELx = 5, DCOx = 3, MODx = 0	2.2 V, 3 V	0.39		0.77	MHz
f <sub>DCO(6,3)</sub>	DCO frequency (6, 3)	RSELx = 6, DCOx = 3, MODx = 0	2.2 V, 3 V	0.54		1.06	MHz
f <sub>DCO(7,3)</sub>	DCO frequency (7, 3)	RSELx = 7, DCOx = 3, MODx = 0	2.2 V, 3 V	0.80		1.50	MHz
f <sub>DCO(8,3)</sub>	DCO frequency (8, 3)	RSELx = 8, DCOx = 3, MODx = 0	2.2 V, 3 V	1.10		2.10	MHz
f <sub>DCO(9,3)</sub>	DCO frequency (9, 3)	RSELx = 9, DCOx = 3, MODx = 0	2.2 V, 3 V	1.60		3.00	MHz
f <sub>DCO(10,3)</sub>	DCO frequency (10, 3)	RSELx = 10, DCOx = 3, MODx = 0	2.2 V, 3 V	2.50		4.30	MHz
f <sub>DCO(11,3)</sub>	DCO frequency (11, 3)	RSELx = 11, DCOx = 3, MODx = 0	2.2 V, 3 V	3.00		5.50	MHz
f <sub>DCO(12,3)</sub>	DCO frequency (12, 3)	RSELx = 12, DCOx = 3, MODx = 0	2.2 V, 3 V	4.30		7.30	MHz
f <sub>DCO(13,3)</sub>	DCO frequency (13, 3)	RSELx = 13, DCOx = 3, MODx = 0	2.2 V, 3 V	6.00		9.60	MHz
f <sub>DCO(14,3)</sub>	DCO frequency (14, 3)	RSELx = 14, DCOx = 3, MODx = 0	2.2 V, 3 V	8.60		13.9	MHz
f <sub>DCO(15,3)</sub>	DCO frequency (15, 3)	RSELx = 15, DCOx = 3, MODx = 0	3 V	12.0		18.5	MHz
f <sub>DCO(15,7)</sub>	DCO frequency (15, 7)	RSELx = 15, DCOx = 7, MODx = 0	3 V	16.0		26.0	MHz
S <sub>RSEL</sub>	Frequency step between range RSEL and RSEL+1	S <sub>RSEL</sub> = f <sub>DCO(RSEL+1,DCO)</sub> / f <sub>DCO(RSEL,DCO)</sub>	2.2 V, 3 V			1.55	ratio
S <sub>DCO</sub>	Frequency step between tap DCO and DCO+1	S <sub>DCO</sub> = f <sub>DCO(RSEL,DCO+1)</sub> / f <sub>DCO(RSEL,DCO)</sub>	2.2 V, 3 V	1.05	1.08	1.12	ratio
	Duty cycle	Measured at P1.4/SMCLK	2.2 V, 3 V	40	50	60	%

### Calibrated DCO Frequencies - Tolerance at Calibration

over recommended ranges of supply voltage and operating free-air temperature (unless otherwise noted)

PARAMETER	TEST CONDITIONS	T <sub>A</sub>	V <sub>CC</sub>	MIN	TYP	MAX	UNIT
Frequency tolerance at calibration		25°C	3 V	-1	±0.2	+1	%
f <sub>CAL(1MHz)</sub> 1-MHz calibration value	BCSCTL1 = CALBC1_1MHZ, DCOCTL = CALDCO_1MHZ, Gating time: 5 ms	25°C	3 V	0.990	1	1.010	MHz
f <sub>CAL(8MHz)</sub> 8-MHz calibration value	BCSCTL1 = CALBC1_8MHZ, DCOCTL = CALDCO_8MHZ, Gating time: 5 ms	25°C	3 V	7.920	8	8.080	MHz
f <sub>CAL(12MHz)</sub> 12-MHz calibration value	BCSCTL1 = CALBC1_12MHZ, DCOCTL = CALDCO_12MHZ, Gating time: 5 ms	25°C	3 V	11.88	12	12.12	MHz
f <sub>CAL(16MHz)</sub> 16-MHz calibration value	BCSCTL1 = CALBC1_16MHZ, DCOCTL = CALDCO_16MHZ, Gating time: 2 ms	25°C	3 V	15.84	16	16.16	MHz

### Calibrated DCO Frequencies - Tolerance Over Temperature 0°C to 85°C

over recommended ranges of supply voltage and operating free-air temperature (unless otherwise noted)

PARAMETER	TEST CONDITIONS	T <sub>A</sub>	V <sub>CC</sub>	MIN	TYP	MAX	UNIT
1-MHz tolerance over temperature		0°C to 85°C	3 V	-2.5	±0.5	+2.5	%
8-MHz tolerance over temperature		0°C to 85°C	3 V	-2.5	±1.0	+2.5	%
12-MHz tolerance over temperature		0°C to 85°C	3 V	-2.5	±1.0	+2.5	%
16-MHz tolerance over temperature		0°C to 85°C	3 V	-3	±2.0	+3	%
f <sub>CAL(1MHz)</sub> 1-MHz calibration value	BCSCTL1 = CALBC1_1MHZ, DCOCTL = CALDCO_1MHZ, Gating time: 5 ms	0°C to 85°C	2.2 V	0.97	1	1.03	MHz
			3 V	0.975	1	1.025	
			3.6 V	0.97	1	1.03	
f <sub>CAL(8MHz)</sub> 8-MHz calibration value	BCSCTL1 = CALBC1_8MHZ, DCOCTL = CALDCO_8MHZ, Gating time: 5 ms	0°C to 85°C	2.2 V	7.76	8	8.4	MHz
			3 V	7.8	8	8.2	
			3.6 V	7.6	8	8.24	
f <sub>CAL(12MHz)</sub> 12-MHz calibration value	BCSCTL1 = CALBC1_12MHZ, DCOCTL = CALDCO_12MHZ, Gating time: 5 ms	0°C to 85°C	2.2 V	11.7	12	12.3	MHz
			3 V	11.7	12	12.3	
			3.6 V	11.7	12	12.3	
f <sub>CAL(16MHz)</sub> 16-MHz calibration value	BCSCTL1 = CALBC1_16MHZ, DCOCTL = CALDCO_16MHZ, Gating time: 2 ms	0°C to 85°C	3 V	15.52	16	16.48	MHz
			3.6 V	15	16	16.48	

### Calibrated DCO Frequencies - Tolerance Over Supply Voltage $V_{CC}$

over recommended ranges of supply voltage and operating free-air temperature (unless otherwise noted)

PARAMETER		TEST CONDITIONS	$T_A$	$V_{CC}$	MIN	TYP	MAX	UNIT
1-MHz tolerance over $V_{CC}$			25°C	1.8 V to 3.6 V	-3	±2	+3	%
8-MHz tolerance over $V_{CC}$			25°C	1.8 V to 3.6 V	-3	±2	+3	%
12-MHz tolerance over $V_{CC}$			25°C	2.2 V to 3.6 V	-3	±2	+3	%
16-MHz tolerance over $V_{CC}$			25°C	3 V to 3.6 V	-6	±2	+3	%
$f_{CAL(1MHz)}$	1-MHz calibration value	BCSCTL1 = CALBC1_1MHZ, DCOCTL = CALDCO_1MHZ, Gating time: 5 ms	25°C	1.8 V to 3.6 V	0.97	1	1.03	MHz
$f_{CAL(8MHz)}$	8-MHz calibration value	BCSCTL1 = CALBC1_8MHZ, DCOCTL = CALDCO_8MHZ, Gating time: 5 ms	25°C	1.8 V to 3.6 V	7.76	8	8.24	MHz
$f_{CAL(12MHz)}$	12-MHz calibration value	BCSCTL1 = CALBC1_12MHZ, DCOCTL = CALDCO_12MHZ, Gating time: 5 ms	25°C	2.2 V to 3.6 V	11.64	12	12.36	MHz
$f_{CAL(16MHz)}$	16-MHz calibration value	BCSCTL1 = CALBC1_16MHZ, DCOCTL = CALDCO_16MHZ, Gating time: 2 ms	25°C	3 V to 3.6 V	15	16	16.48	MHz

### Calibrated DCO Frequencies - Overall Tolerance

over recommended ranges of supply voltage and operating free-air temperature (unless otherwise noted)

PARAMETER		TEST CONDITIONS	$T_A$	$V_{CC}$	MIN	TYP	MAX	UNIT
1-MHz tolerance overall			-40°C to 105°C	1.8 V to 3.6 V	-5	±2	+5	%
8-MHz tolerance overall			-40°C to 105°C	1.8 V to 3.6 V	-5	±2	+5	%
12-MHz tolerance overall			-40°C to 105°C	2.2 V to 3.6 V	-5	±2	+5	%
16-MHz tolerance overall			-40°C to 105°C	3 V to 3.6 V	-6	±3	+6	%
$f_{CAL(1MHz)}$	1-MHz calibration value	BCSCTL1 = CALBC1_1MHZ, DCOCTL = CALDCO_1MHZ, Gating time: 5 ms	-40°C to 105°C	1.8 V to 3.6 V	0.95	1	1.05	MHz
$f_{CAL(8MHz)}$	8-MHz calibration value	BCSCTL1 = CALBC1_8MHZ, DCOCTL = CALDCO_8MHZ, Gating time: 5 ms	-40°C to 105°C	1.8 V to 3.6 V	7.6	8	8.4	MHz
$f_{CAL(12MHz)}$	12-MHz calibration value	BCSCTL1 = CALBC1_12MHZ, DCOCTL = CALDCO_12MHZ, Gating time: 5 ms	-40°C to 105°C	2.2 V to 3.6 V	11.4	12	12.6	MHz
$f_{CAL(16MHz)}$	16-MHz calibration value	BCSCTL1 = CALBC1_16MHZ, DCOCTL = CALDCO_16MHZ, Gating time: 2 ms	-40°C to 105°C	3 V to 3.6 V	15	16	17	MHz

Typical Characteristics - Calibrated 1-MHz DCO Frequency

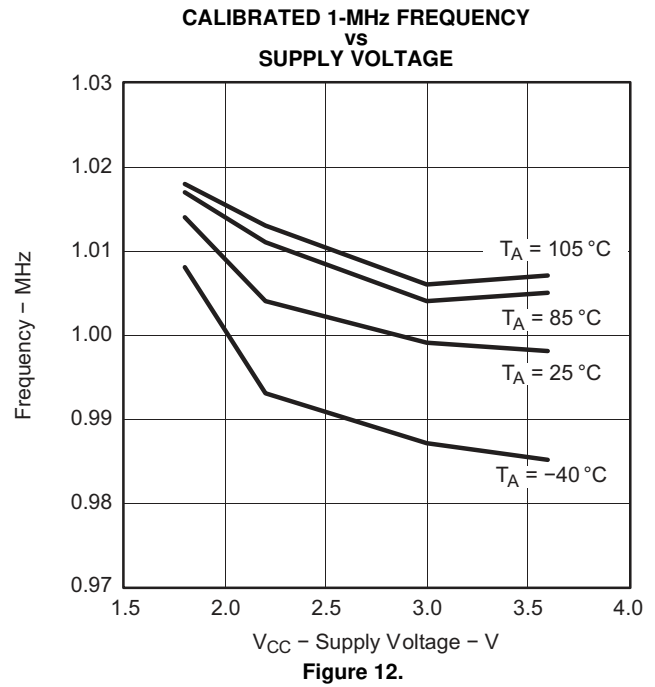
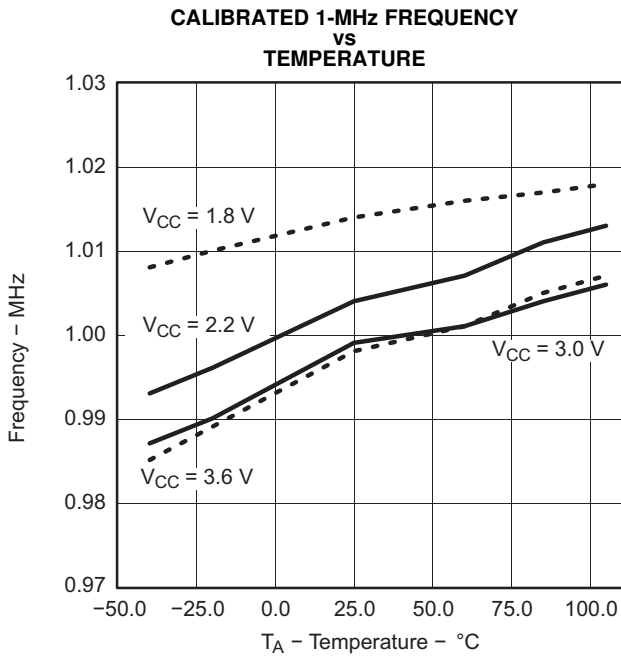

### Wake-Up From Lower-Power Modes (LPM3/4)

over recommended ranges of supply voltage and operating free-air temperature (unless otherwise noted)

PARAMETER	TEST CONDITIONS	V <sub>CC</sub>	MIN	TYP	MAX	UNIT
t <sub>DCO,LPM3/4</sub> DCO clock wake-up time from LPM3/4 <sup>(1)</sup>	BCSCTL1 = CALBC1_1MHZ, DCOCTL = CALDCO_1MHZ	2.2 V, 3 V			2	μs
	BCSCTL1 = CALBC1_8MHZ, DCOCTL = CALDCO_8MHZ			1.5		
	BCSCTL1 = CALBC1_12MHZ, DCOCTL = CALDCO_12MHZ			1		
	BCSCTL1 = CALBC1_16MHZ, DCOCTL = CALDCO_16MHZ	3 V		1		
t <sub>CPU,LPM3/4</sub> CPU wake-up time from LPM3/4 <sup>(2)</sup>				1 / f <sub>MCLK</sub> + t <sub>clock,LPM3/4</sub>		

- (1) The DCO clock wake-up time is measured from the edge of an external wake-up signal (for example, a port interrupt) to the first clock edge observable externally on a clock pin (MCLK or SMCLK).
- (2) Parameter applicable only if DCOCLK is used for MCLK.

### Typical Characteristics - DCO Clock Wake-Up Time From LPM3/4

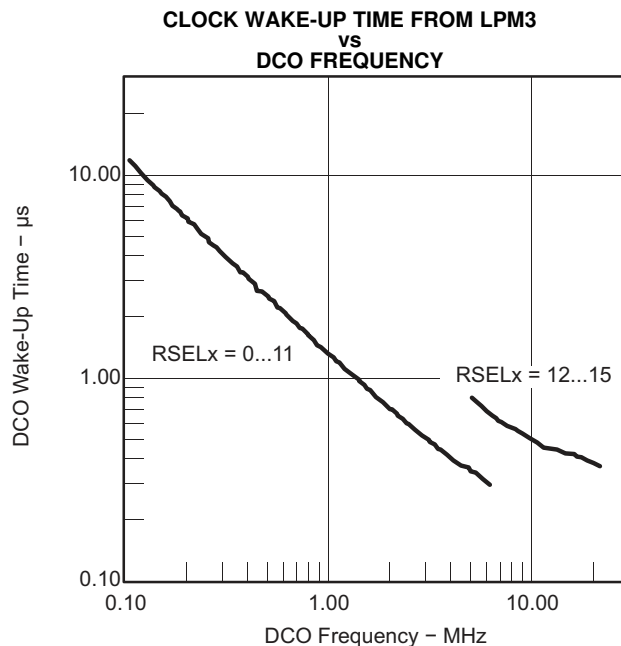

Figure 13.

### DCO With External Resistor $R_{OSC}^{(1)}$

over recommended ranges of supply voltage and operating free-air temperature (unless otherwise noted)

PARAMETER	TEST CONDITIONS	$V_{CC}$	MIN	TYP	MAX	UNIT
$f_{DCO,ROSC}$ DCO output frequency with $R_{OSC}$	DCOR = 1, RSELx = 4, DCOx = 3, MODx = 0, $T_A = 25^\circ C$	2.2 V		1.8		MHz
		3 V		1.95		
$D_T$ Temperature drift	DCOR = 1, RSELx = 4, DCOx = 3, MODx = 0	2.2 V, 3 V		$\pm 0.1$		%/ $^\circ C$
$D_V$ Drift with $V_{CC}$	DCOR = 1, RSELx = 4, DCOx = 3, MODx = 0	2.2 V, 3 V		10		%/V

(1)  $R_{OSC} = 100\text{ k}\Omega$ . Metal film resistor, type 0257, 0.6 W with 1% tolerance and  $T_K = \pm 50\text{ ppm}/^\circ C$ .

#### Typical Characteristics - DCO With External Resistor $R_{OSC}$

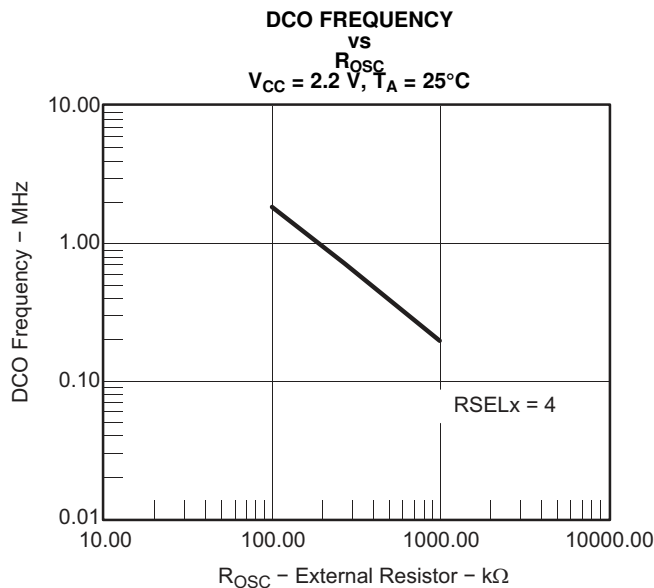

Figure 14.

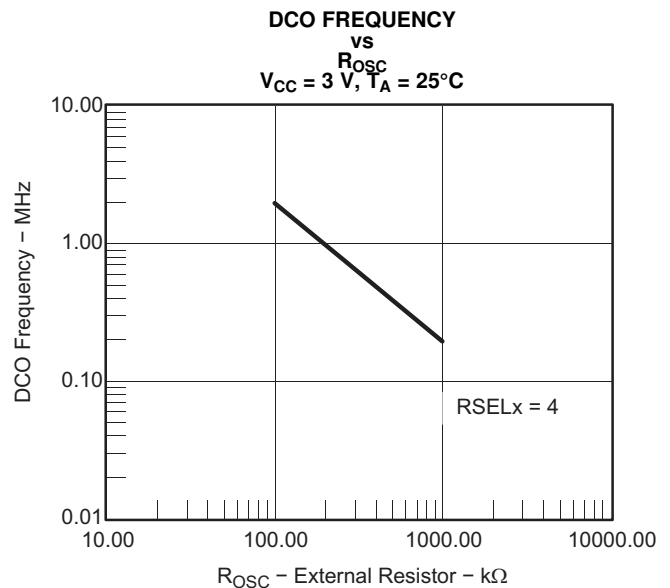

Figure 15.

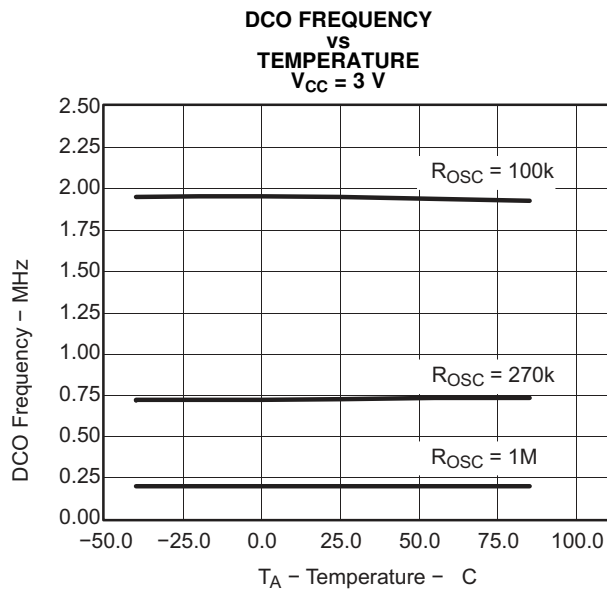

Figure 16.

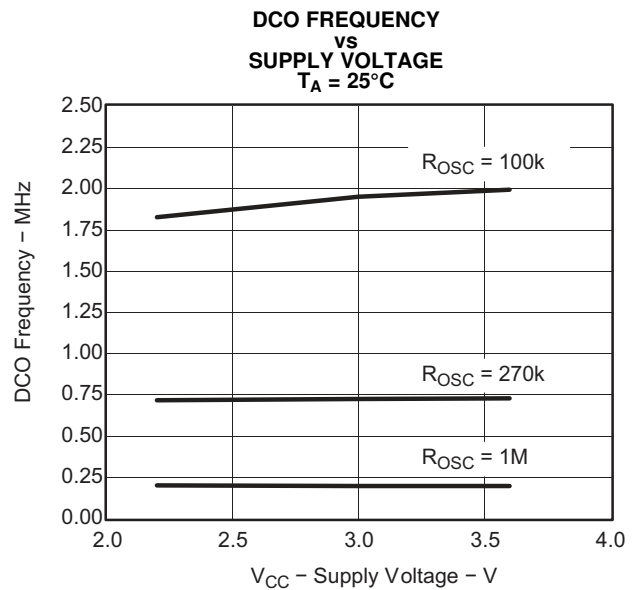

Figure 17.



## Crystal Oscillator LFXT1, Low-Frequency Mode<sup>(1)</sup>

over recommended ranges of supply voltage and operating free-air temperature (unless otherwise noted)

PARAMETER		TEST CONDITIONS	V <sub>CC</sub>	MIN	TYP	MAX	UNIT
f <sub>LFXT1,LF</sub>	LFXT1 oscillator crystal frequency, LF mode 0, 1	XTS = 0, LFXT1Sx = 0 or 1	1.8 V to 3.6 V		32768		Hz
f <sub>LFXT1,LF,logic</sub>	LFXT1 oscillator logic level square wave input frequency, LF mode	XTS = 0, LFXT1Sx = 3	1.8 V to 3.6 V	10000	32768	50000	Hz
O <sub>A,LF</sub>	Oscillation allowance for LF crystals	XTS = 0, LFXT1Sx = 0, f <sub>LFXT1,LF</sub> = 32768 Hz, C <sub>L,eff</sub> = 6 pF			500		kΩ
		XTS = 0, LFXT1Sx = 0, f <sub>LFXT1,LF</sub> = 32768 Hz, C <sub>L,eff</sub> = 12 pF			200		
C <sub>L,eff</sub>	Integrated effective load capacitance, LF mode <sup>(2)</sup>	XTS = 0, XCAPx = 0			1		pF
		XTS = 0, XCAPx = 1			5.5		
		XTS = 0, XCAPx = 2			8.5		
		XTS = 0, XCAPx = 3			11		
	Duty cycle, LF mode	XTS = 0, Measured at P2.0/ACLK, f <sub>LFXT1,LF</sub> = 32768 Hz	2.2 V, 3 V	30	50	70	%
f <sub>Fault,LF</sub>	Oscillator fault frequency, LF mode <sup>(3)</sup>	XTS = 0, LFXT1Sx = 3 <sup>(4)</sup>	2.2 V, 3 V	10		10000	Hz

- (1) To improve EMI on the XT1 oscillator, the following guidelines should be observed.
  - (a) Keep the trace between the device and the crystal as short as possible.
  - (b) Design a good ground plane around the oscillator pins.
  - (c) Prevent crosstalk from other clock or data lines into oscillator pins XIN and XOUT.
  - (d) Avoid running PCB traces underneath or adjacent to the XIN and XOUT pins.
  - (e) Use assembly materials and praxis to avoid any parasitic load on the oscillator XIN and XOUT pins.
  - (f) If conformal coating is used, ensure that it does not induce capacitive/resistive leakage between the oscillator pins.
  - (g) Do not route the XOUT line to the JTAG header to support the serial programming adapter as shown in other documentation. This signal is no longer required for the serial programming adapter.
- (2) Includes parasitic bond and package capacitance (approximately 2 pF per pin).  
Because the PCB adds additional capacitance, it is recommended to verify the correct load by measuring the ACLK frequency. For a correct setup, the effective load capacitance should always match the specification of the crystal that is used.
- (3) Frequencies below the MIN specification set the fault flag. Frequencies above the MAX specification do not set the fault flag. Frequencies in between might set the flag.
- (4) Measured with logic-level input frequency but also applies to operation with crystals.

## Internal Very-Low-Power Low-Frequency Oscillator (VLO)

over recommended ranges of supply voltage and operating free-air temperature (unless otherwise noted)

PARAMETER		T <sub>A</sub>	V <sub>CC</sub>	MIN	TYP	MAX	UNIT
f <sub>VLO</sub>	VLO frequency	-40°C to 85°C	2.2 V, 3 V	4	12	20	kHz
		105°C					
df <sub>VLO</sub> /dT	VLO frequency temperature drift <sup>(1)</sup>	-40°C to 105°C	2.2 V, 3 V		0.5		%/°C
df <sub>VLO</sub> /dV <sub>CC</sub>	VLO frequency supply voltage drift <sup>(2)</sup>	25°C	1.8 V to 3.6 V		4		%/V

- (1) Calculated using the box method:  
I version: [MAX(-40...85°C) - MIN(-40...85°C)]/MIN(-40...85°C)/[85°C - (-40°C)]  
T version: [MAX(-40...105°C) - MIN(-40...105°C)]/MIN(-40...105°C)/[105°C - (-40°C)]
- (2) Calculated using the box method: [MAX(1.8...3.6 V) - MIN(1.8...3.6 V)]/MIN(1.8...3.6 V)/(3.6 V - 1.8 V)

**Crystal Oscillator LFXT1, High-Frequency Mode<sup>(1)</sup>**

PARAMETER		TEST CONDITIONS	V <sub>CC</sub>	MIN	TYP	MAX	UNIT
f <sub>LFXT1,HF0</sub>	LFXT1 oscillator crystal frequency, HF mode 0	XTS = 1, LFXT1Sx = 0	1.8 V to 3.6 V	0.4		1	MHz
f <sub>LFXT1,HF1</sub>	LFXT1 oscillator crystal frequency, HF mode 1	XTS = 1, LFXT1Sx = 1	1.8 V to 3.6 V	1		4	MHz
f <sub>LFXT1,HF2</sub>	LFXT1 oscillator crystal frequency, HF mode 2	XTS = 1, LFXT1Sx = 2	1.8 V to 3.6 V	2		10	MHz
			2.2 V to 3.6 V	2		12	
			3 V to 3.6 V	2		16	
f <sub>LFXT1,HF,logic</sub>	LFXT1 oscillator logic-level square-wave input frequency, HF mode	XTS = 1, LFXT1Sx = 3	1.8 V to 3.6 V	0.4		10	MHz
			2.2 V to 3.6 V	0.4		12	
			3 V to 3.6 V	0.4		16	
O <sub>AHF</sub>	Oscillation allowance for HF crystals (see <a href="#">Figure 18</a> and <a href="#">Figure 19</a> )	XTS = 1, LFXT1Sx = 0, f <sub>LFXT1,HF</sub> = 1 MHz, C <sub>L,eff</sub> = 15 pF			2700		Ω
		XTS = 1, LFXT1Sx = 1, f <sub>LFXT1,HF</sub> = 4 MHz, C <sub>L,eff</sub> = 15 pF			800		
		XTS = 1, LFXT1Sx = 2, f <sub>LFXT1,HF</sub> = 16 MHz, C <sub>L,eff</sub> = 15 pF			300		
C <sub>L,eff</sub>	Integrated effective load capacitance, HF mode <sup>(2)</sup>	XTS = 1 <sup>(3)</sup>			1		pF
	Duty cycle, HF mode	XTS = 1, Measured at P2.0/ACLK, f <sub>LFXT1,HF</sub> = 10 MHz	2.2 V, 3 V	40	50	60	%
		XTS = 1, Measured at P2.0/ACLK, f <sub>LFXT1,HF</sub> = 16 MHz		40	50	60	
f <sub>Fault,HF</sub>	Oscillator fault frequency <sup>(4)</sup>	XTS = 1, LFXT1Sx = 3 <sup>(5)</sup>	2.2 V, 3 V	30		300	kHz

- (1) To improve EMI on the XT1 oscillator the following guidelines should be observed:
  - (a) Keep the trace between the device and the crystal as short as possible.
  - (b) Design a good ground plane around the oscillator pins.
  - (c) Prevent crosstalk from other clock or data lines into oscillator pins XIN and XOUT.
  - (d) Avoid running PCB traces underneath or adjacent to the XIN and XOUT pins.
  - (e) Use assembly materials and praxis to avoid any parasitic load on the oscillator XIN and XOUT pins.
  - (f) If conformal coating is used, ensure that it does not induce capacitive/resistive leakage between the oscillator pins.
  - (g) Do not route the XOUT line to the JTAG header to support the serial programming adapter as shown in other documentation. This signal is no longer required for the serial programming adapter.
- (2) Includes parasitic bond and package capacitance (approximately 2 pF per pin). Because the PCB adds additional capacitance, it is recommended to verify the correct load by measuring the ACLK frequency. For a correct setup, the effective load capacitance should always match the specification of the used crystal.
- (3) Requires external capacitors at both terminals. Values are specified by crystal manufacturers.
- (4) Frequencies below the MIN specification set the fault flag, frequencies above the MAX specification do not set the fault flag, and frequencies in between might set the flag.
- (5) Measured with logic-level input frequency, but also applies to operation with crystals.

Typical Characteristics - LFXT1 Oscillator in HF Mode (XTS = 1)

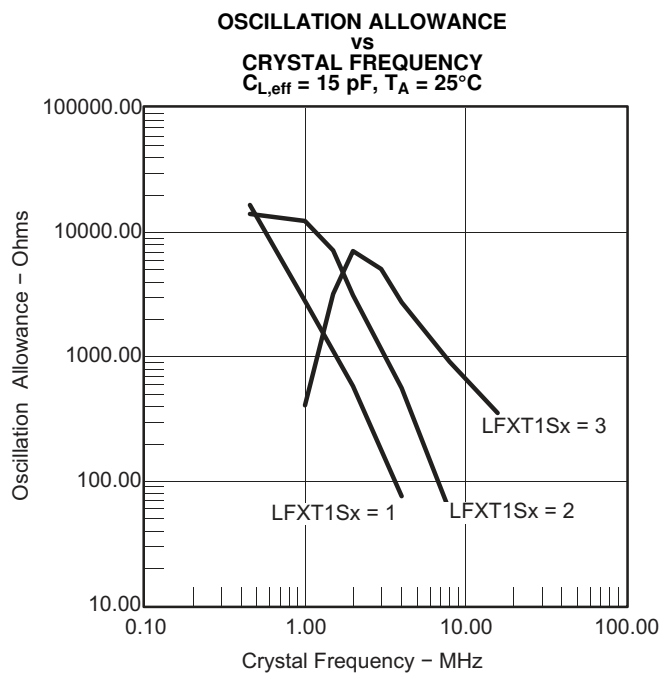

Figure 18.

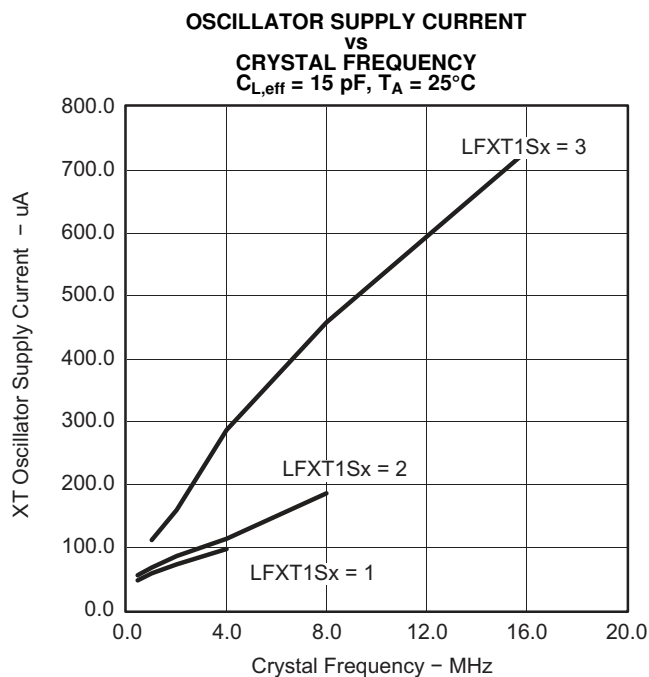

Figure 19.

Timer\_A

over recommended ranges of supply voltage and operating free-air temperature (unless otherwise noted)

PARAMETER	TEST CONDITIONS	V <sub>CC</sub>	MIN	TYP	MAX	UNIT
f <sub>TA</sub> Timer_A clock frequency	Internal: SMCLK, ACLK External: TACLK, INCLK Duty cycle = 50% ± 10%	2.2 V			10	MHz
		3 V			16	
t <sub>TA,cap</sub> Timer_A capture timing	TA0, TA1, TA2	2.2 V, 3 V	20			ns

Timer\_B

over recommended ranges of supply voltage and operating free-air temperature (unless otherwise noted)

PARAMETER	TEST CONDITIONS	V <sub>CC</sub>	MIN	TYP	MAX	UNIT
f <sub>TB</sub> Timer_B clock frequency	Internal: SMCLK, ACLK External: TACLK, INCLK Duty cycle = 50% ± 10%	2.2 V			10	MHz
		3 V			16	
t <sub>TB,cap</sub> Timer_B capture timing	TB0, TB1, TB2	2.2 V, 3 V	20			ns

### USCI (UART Mode)

over recommended ranges of supply voltage and operating free-air temperature (unless otherwise noted)

PARAMETER		CONDITIONS	V <sub>CC</sub>	MIN	TYP	MAX	UNIT
f <sub>USCI</sub>	USCI input clock frequency	Internal: SMCLK, ACLK External: UCLK Duty cycle = 50% ± 10%				f <sub>SYSTEM</sub>	MHz
f <sub>BITCLK</sub>	BITCLK clock frequency (equals baud rate in Mbaud)		2.2 V, 3 V			1	MHz
t <sub>r</sub>	UART receive deglitch time <sup>(1)</sup>		2.2 V	50	150	600	ns
			3 V	50	100	600	

(1) Pulses on the UART receive input (UCxRX) shorter than the UART receive deglitch time are suppressed. To ensure that pulses are correctly recognized their width should exceed the maximum specification of the deglitch time.

### USCI (SPI Master Mode)<sup>(1)</sup>

over recommended ranges of supply voltage and operating free-air temperature (unless otherwise noted)

(see [Figure 20](#) and [Figure 21](#))

PARAMETER		TEST CONDITIONS	V <sub>CC</sub>	MIN	TYP	MAX	UNIT
f <sub>USCI</sub>	USCI input clock frequency	SMCLK, ACLK Duty cycle = 50% ± 10%				f <sub>SYSTEM</sub>	MHz
t <sub>SU,MI</sub>	SOMI input data setup time		2.2 V	110			ns
			3 V	75			
t <sub>HD,MI</sub>	SOMI input data hold time		2.2 V	0			ns
			3 V	0			
t <sub>VALID,MO</sub>	SIMO output data valid time	UCLK edge to SIMO valid, C <sub>L</sub> = 20 pF	2.2 V			30	ns
			3 V			20	

(1) f<sub>UCxCLK</sub> = 1/2t<sub>LO/HI</sub> with t<sub>LO/HI</sub> ≥ max(t<sub>VALID,MO(USCI)</sub> + t<sub>SU,SI(Slave)</sub>, t<sub>SU,MI(USCI)</sub> + t<sub>VALID,SO(Slave)</sub>).  
For the slave's parameters t<sub>SU,SI(Slave)</sub> and t<sub>VALID,SO(Slave)</sub>, see the SPI parameters of the attached slave.

### USCI (SPI Slave Mode)<sup>(1)</sup>

over recommended ranges of supply voltage and operating free-air temperature (unless otherwise noted)

(see [Figure 22](#) and [Figure 23](#))

PARAMETER		TEST CONDITIONS	V <sub>CC</sub>	MIN	TYP	MAX	UNIT
t <sub>STE,LEAD</sub>	STE lead time, STE low to clock		2.2 V, 3 V		50		ns
t <sub>STE,LAG</sub>	STE lag time, Last clock to STE high		2.2 V, 3 V	10			ns
t <sub>STE,ACC</sub>	STE access time, STE low to SOMI data out		2.2 V, 3 V		50		ns
t <sub>STE,DIS</sub>	STE disable time, STE high to SOMI high impedance		2.2 V, 3 V		50		ns
t <sub>SU,SI</sub>	SIMO input data setup time		2.2 V	20			ns
			3 V	15			
t <sub>HD,SI</sub>	SIMO input data hold time		2.2 V	10			ns
			3 V	10			
t <sub>VALID,SO</sub>	SOMI output data valid time	UCLK edge to SOMI valid, C <sub>L</sub> = 20 pF	2.2 V		75	110	ns
			3 V		50	75	

(1) f<sub>UCxCLK</sub> = 1/2t<sub>LO/HI</sub> with t<sub>LO/HI</sub> ≥ max(t<sub>VALID,MO(Master)</sub> + t<sub>SU,SI(USCI)</sub>, t<sub>SU,MI(Master)</sub> + t<sub>VALID,SO(USCI)</sub>).  
For the master's parameters t<sub>SU,MI(Master)</sub> and t<sub>VALID,MO(Master)</sub>, see the SPI parameters of the attached slave.

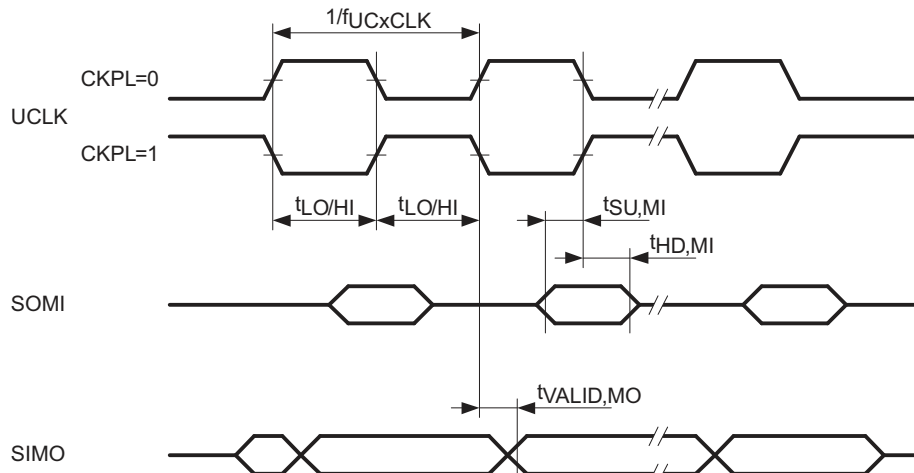

Figure 20. SPI Master Mode, CKPH = 0

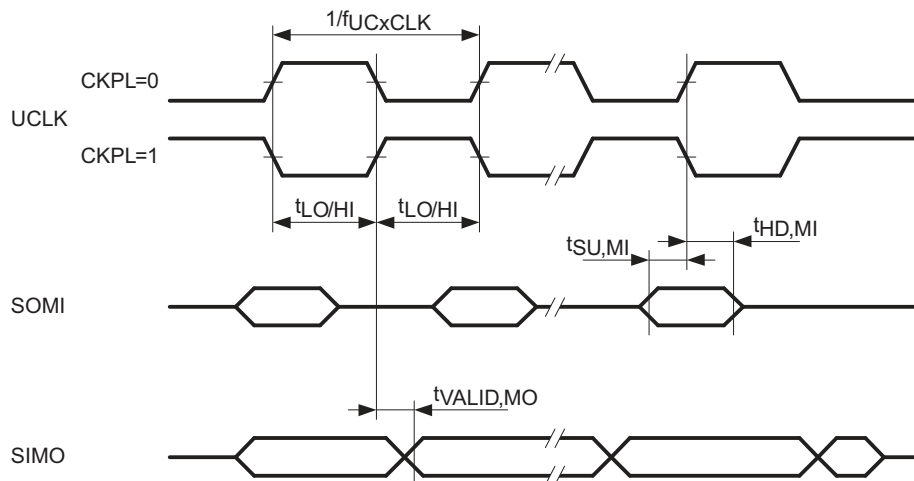
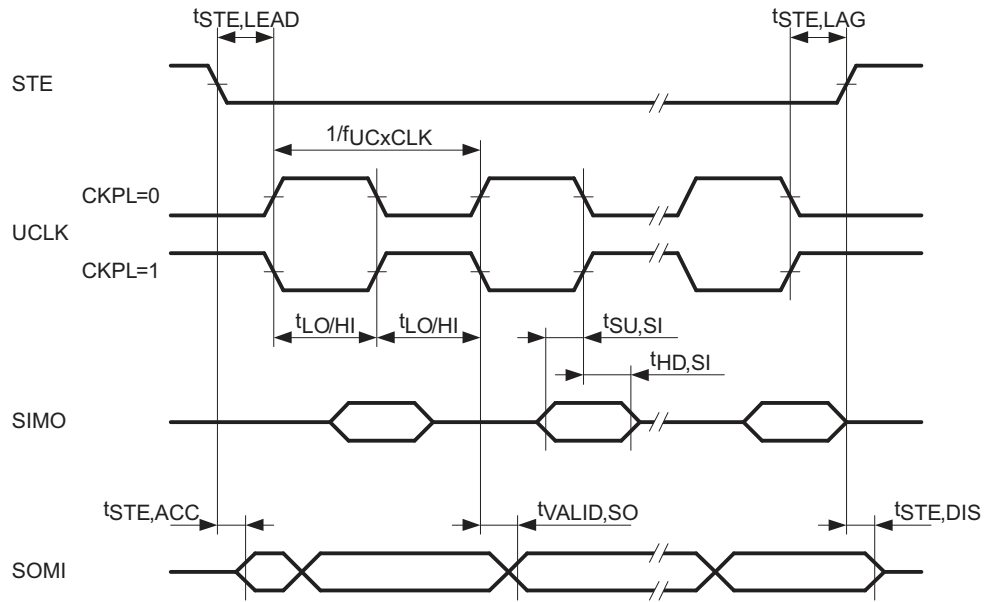
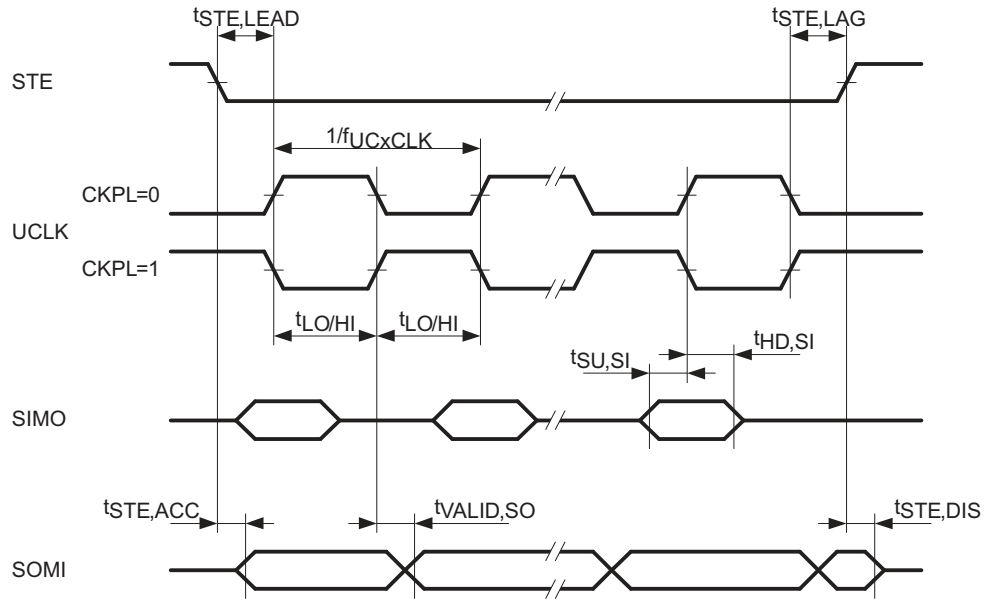

Figure 21. SPI Master Mode, CKPH = 1



**Figure 22. SPI Slave Mode, CKPH = 0**



**Figure 23. SPI Slave Mode, CKPH = 1**

## USCI (I2C Mode)

over recommended ranges of supply voltage and operating free-air temperature (unless otherwise noted) (see [Figure 24](#))

PARAMETER	TEST CONDITIONS	V <sub>CC</sub>	MIN	TYP	MAX	UNIT	
f <sub>USCI</sub>	USCI input clock frequency				f <sub>SYSTEM</sub>	MHz	
f <sub>SCL</sub>	SCL clock frequency	2.2 V, 3 V	0		400	kHz	
t <sub>HD,STA</sub>	Hold time (repeated) START	f <sub>SCL</sub> ≤ 100 kHz f <sub>SCL</sub> > 100 kHz	2.2 V, 3 V	4 0.6		μs	
t <sub>SU,STA</sub>	Setup time for a repeated START	f <sub>SCL</sub> ≤ 100 kHz f <sub>SCL</sub> > 100 kHz	2.2 V, 3 V	4.7 0.6		μs	
t <sub>HD,DAT</sub>	Data hold time		2.2 V, 3 V	0		ns	
t <sub>SU,DAT</sub>	Data setup time		2.2 V, 3 V	250		ns	
t <sub>SU,STO</sub>	Setup time for STOP		2.2 V, 3 V	4		μs	
t <sub>SP</sub>	Pulse width of spikes suppressed by input filter		2.2 V 3 V	50 50	150 100	600 600	ns

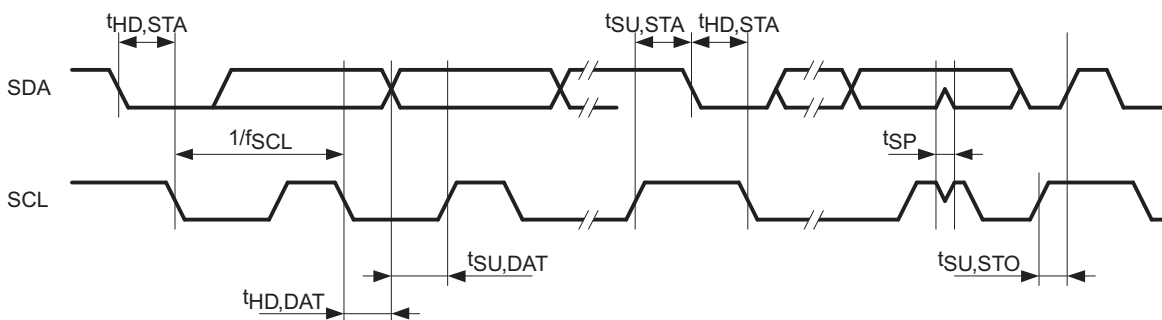

Figure 24. I2C Mode Timing

### 10-Bit ADC, Power Supply and Input Range Conditions<sup>(1)</sup>

over recommended ranges of supply voltage and operating free-air temperature (unless otherwise noted)<sup>(1)</sup>

PARAMETER		TEST CONDITIONS	T <sub>A</sub>	V <sub>CC</sub>	MIN	TYP	MAX	UNIT
V <sub>CC</sub>	Analog supply voltage range	V <sub>SS</sub> = 0 V			2.2		3.6	V
V <sub>Ax</sub>	Analog input voltage range <sup>(2)</sup>	All Ax terminals, Analog inputs selected in ADC10AE register			0		V <sub>CC</sub>	V
I <sub>ADC10</sub>	ADC10 supply current <sup>(3)</sup>	f <sub>ADC10CLK</sub> = 5 MHz, ADC10ON = 1, REFON = 0, ADC10SHT0 = 1, ADC10SHT1 = 0, ADC10DIV = 0	-40°C to 105°C	2.2 V	0.52	1.05	mA	
				3 V	0.6	1.2		
I <sub>REF+</sub>	Reference supply current, reference buffer disabled <sup>(4)</sup>	f <sub>ADC10CLK</sub> = 5 MHz, ADC10ON = 0, REF2_5V = 0, REFON = 1, REFOUT = 0	-40°C to 105°C	2.2 V, 3 V	0.25	0.4	mA	
		f <sub>ADC10CLK</sub> = 5 MHz, ADC10ON = 0, REF2_5V = 1, REFON = 1, REFOUT = 0		3 V	0.25	0.4		
I <sub>REFB,0</sub>	Reference buffer supply current with ADC10SR = 0 <sup>(4)</sup>	f <sub>ADC10CLK</sub> = 5 MHz, ADC10ON = 0, REFON = 1, REF2_5V = 0, REFOUT = 1, ADC10SR = 0	-40°C to 85°C	2.2 V, 3 V	1.1	1.4	mA	
			105°C	2.2 V, 3 V		1.8		
I <sub>REFB,1</sub>	Reference buffer supply current with ADC10SR = 1 <sup>(4)</sup>	f <sub>ADC10CLK</sub> = 5 MHz, ADC10ON = 0, REFON = 1, REF2_5V = 0, REFOUT = 1, ADC10SR = 1	-40°C to 85°C	2.2 V, 3 V	0.5	0.7	mA	
			105°C	2.2 V, 3 V		0.8		
C <sub>I</sub>	Input capacitance	Only one terminal Ax selected at a time	-40°C to 105°C				27	pF
R <sub>I</sub>	Input MUX ON resistance	0 V ≤ V <sub>Ax</sub> ≤ V <sub>CC</sub>	-40°C to 105°C	2.2 V, 3 V			2000	Ω

- (1) The leakage current is defined in the leakage current table with P<sub>x.x</sub>/A<sub>x</sub> parameter.
- (2) The analog input voltage range must be within the selected reference voltage range V<sub>R+</sub> to V<sub>R-</sub> for valid conversion results.
- (3) The internal reference supply current is not included in current consumption parameter I<sub>ADC10</sub>.
- (4) The internal reference current is supplied via terminal V<sub>CC</sub>. Consumption is independent of the ADC10ON control bit, unless a conversion is active. The REFON bit enables the built-in reference to settle before starting an A/D conversion.



## 10-Bit ADC, Built-In Voltage Reference

over recommended ranges of supply voltage and operating free-air temperature (unless otherwise noted)

PARAMETER		TEST CONDITIONS		V <sub>CC</sub>	MIN	TYP	MAX	UNIT
V <sub>CC,REF+</sub>	Positive built-in reference analog supply voltage range	I <sub>VREF+</sub> ≤ 1 mA, REF2_5V = 0			2.2			V
		I <sub>VREF+</sub> ≤ 0.5 mA, REF2_5V = 1			2.8			
		I <sub>VREF+</sub> ≤ 1 mA, REF2_5V = 1			2.9			
V <sub>REF+</sub>	Positive built-in reference voltage	I <sub>VREF+</sub> ≤ I <sub>VREF+,max</sub> , REF2_5V = 0		2.2 V, 3 V	1.41	1.5	1.59	V
		I <sub>VREF+</sub> ≤ I <sub>VREF+,max</sub> , REF2_5V = 1		3 V	2.35	2.5	2.65	
I <sub>LD,VREF+</sub>	Maximum V <sub>REF+</sub> load current			2.2 V	±0.5			mA
				3 V	±1			
V <sub>REF+</sub> load regulation	V <sub>REF+</sub> load regulation	I <sub>VREF+</sub> = 500 μA ± 100 μA, Analog input voltage V <sub>AX</sub> ≈ 0.75 V, REF2_5V = 0		2.2 V, 3 V	±2			LSB
		I <sub>VREF+</sub> = 500 μA ± 100 μA, Analog input voltage V <sub>AX</sub> ≈ 1.25 V, REF2_5V = 1		3 V	±2			
V <sub>REF+</sub> load regulation response time	V <sub>REF+</sub> load regulation response time	I <sub>VREF+</sub> = 100 μA to 900 μA, V <sub>AX</sub> ≈ 0.5 × V <sub>REF+</sub> , Error of conversion result ≤ 1 LSB	ADC10SR = 0	3 V	400			ns
			ADC10SR = 1		2000			
C <sub>VREF+</sub>	Maximum capacitance at pin V <sub>REF+</sub> <sup>(1)</sup>	I <sub>VREF+</sub> ≤ ±1 mA, REFON = 1, REFOUT = 1		2.2 V, 3 V	100			pF
T <sub>CREF+</sub>	Temperature coefficient	I <sub>VREF+</sub> = constant with 0 mA ≤ I <sub>VREF+</sub> ≤ 1 mA		2.2 V, 3 V	±100			ppm/°C
t <sub>REFON</sub>	Settling time of internal reference voltage <sup>(2)</sup>	I <sub>VREF+</sub> = 0.5 mA, REF2_5V = 0, REFON = 0 to 1		3.6 V	30			μs
t <sub>REFBURST</sub>	Settling time of reference buffer <sup>(2)</sup>	I <sub>VREF+</sub> = 0.5 mA, REF2_5V = 0, REFON = 1, REFBURST = 1	ADC10SR = 0	2.2 V	1			μs
			ADC10SR = 1		2.5			
		I <sub>VREF+</sub> = 0.5 mA, REF2_5V = 1, REFON = 1, REFBURST = 1	ADC10SR = 0	3 V	2			
			ADC10SR = 1		4.5			

(1) The capacitance applied to the internal buffer operational amplifier, if switched to terminal P2.4/TA 2/A4/V<sub>REF+</sub>/V<sub>eREF+</sub> (REFOUT = 1), must be limited; the reference buffer may become unstable otherwise.

(2) The condition is that the error in a conversion started after t<sub>REFON</sub> or t<sub>RefBuf</sub> is less than ±0.5 LSB.

### 10-Bit ADC, External Reference<sup>(1)</sup>

over recommended ranges of supply voltage and operating free-air temperature (unless otherwise noted)

PARAMETER		TEST CONDITIONS	V <sub>CC</sub>	MIN	MAX	UNIT
V <sub>eREF+</sub>	Positive external reference input voltage range <sup>(2)</sup>	V <sub>eREF+</sub> > V <sub>eREF-</sub> , SREF1 = 1, SREF0 = 0		1.4	V <sub>CC</sub>	V
		V <sub>eREF-</sub> ≤ V <sub>eREF+</sub> ≤ V <sub>CC</sub> - 0.15 V, SREF1 = 1, SREF0 = 1 <sup>(3)</sup>		1.4	3	
V <sub>eREF-</sub>	Negative external reference input voltage range <sup>(4)</sup>	V <sub>eREF+</sub> > V <sub>eREF-</sub>		0	1.2	V
ΔV <sub>eREF</sub>	Differential external reference input voltage range ΔV <sub>eREF</sub> = V <sub>eREF+</sub> - V <sub>eREF-</sub>	V <sub>eREF+</sub> > V <sub>eREF-</sub> <sup>(5)</sup>		1.4	V <sub>CC</sub>	V
I <sub>vREF+</sub>	Static input current into V <sub>eREF+</sub>	0 V ≤ V <sub>eREF+</sub> ≤ V <sub>CC</sub> , SREF1 = 1, SREF0 = 0	2.2 V, 3 V	±1		μA
		0 V ≤ V <sub>eREF+</sub> ≤ V <sub>CC</sub> - 0.15 V ≤ 3 V, SREF1 = 1, SREF0 = 1 <sup>(3)</sup>		0		
I <sub>vREF-</sub>	Static input current into V <sub>eREF-</sub>	0 V ≤ V <sub>eREF-</sub> ≤ V <sub>CC</sub>	2.2 V, 3 V	±1		μA

- (1) The external reference is used during conversion to charge and discharge the capacitance array. The input capacitance, C<sub>I</sub>, is also the dynamic load for an external reference during conversion. The dynamic impedance of the reference supply should follow the recommendations on analog-source impedance to allow the charge to settle for 10-bit accuracy.
- (2) The accuracy limits the minimum positive external reference voltage. Lower reference voltage levels may be applied with reduced accuracy requirements.
- (3) Under this condition, the external reference is internally buffered. The reference buffer is active and requires the reference buffer supply current I<sub>REFB</sub>. The current consumption can be limited to the sample and conversion period with REBURST = 1.
- (4) The accuracy limits the maximum negative external reference voltage. Higher reference voltage levels may be applied with reduced accuracy requirements.
- (5) The accuracy limits the minimum external differential reference voltage. Lower differential reference voltage levels may be applied with reduced accuracy requirements.

### 10-Bit ADC, Timing Parameters

over recommended ranges of supply voltage and operating free-air temperature (unless otherwise noted)

PARAMETER		TEST CONDITIONS	V <sub>CC</sub>	MIN	TYP	MAX	UNIT
f <sub>ADC10CLK</sub>	ADC10 input clock frequency	For specified performance of ADC10 linearity parameters	2.2 V, 3 V	ADC10SR = 0	0.45	6.3	MHz
				ADC10SR = 1	0.45	1.5	
f <sub>ADC10OSC</sub>	ADC10 built-in oscillator frequency	ADC10DIVx = 0, ADC10SSELx = 0, f <sub>ADC10CLK</sub> = f <sub>ADC10OSC</sub>	2.2 V, 3 V	3.7		6.3	MHz
t <sub>CONVERT</sub>	Conversion time	ADC10 built-in oscillator, ADC10SSELx = 0, f <sub>ADC10CLK</sub> = f <sub>ADC10OSC</sub>	2.2 V, 3 V	2.06		3.51	μs
		f <sub>ADC10CLK</sub> from ACLK, MCLK or SMCLK, ADC10SSELx ≠ 0		13 × ADC10DIVx × 1 / f <sub>ADC10CLK</sub>			
t <sub>ADC10ON</sub>	Turn on settling time of the ADC <sup>(1)</sup>					100	ns

- (1) The condition is that the error in a conversion started after t<sub>ADC10ON</sub> is less than ±0.5 LSB. The reference and input signal are already settled.

## 10-Bit ADC, Linearity Parameters

over recommended ranges of supply voltage and operating free-air temperature (unless otherwise noted)

PARAMETER		TEST CONDITIONS	V <sub>CC</sub>	MIN	TYP	MAX	UNIT
E <sub>I</sub>	Integral linearity error		2.2 V, 3 V			±1	LSB
E <sub>D</sub>	Differential linearity error		2.2 V, 3 V			±1	LSB
E <sub>O</sub>	Offset error	Source impedance R <sub>S</sub> < 100 Ω	2.2 V, 3 V			±1	LSB
E <sub>G</sub>	Gain error	SREF <sub>X</sub> = 010, unbuffered external reference, V <sub>eREF+</sub> = 1.5 V	2.2 V		±1.1	±2	LSB
		SREF <sub>X</sub> = 010, unbuffered external reference, V <sub>eREF+</sub> = 2.5 V	3 V		±1.1	±2	
		SREF <sub>X</sub> = 011, buffered external reference <sup>(1)</sup> , V <sub>eREF+</sub> = 1.5 V	2.2 V		±1.1	±4	
		SREF <sub>X</sub> = 011, buffered external reference <sup>(1)</sup> , V <sub>eREF+</sub> = 2.5 V	3 V		±1.1	±3	
E <sub>T</sub>	Total unadjusted error	SREF <sub>X</sub> = 010, unbuffered external reference, V <sub>eREF+</sub> = 1.5 V	2.2 V		±2	±5	LSB
		SREF <sub>X</sub> = 010, unbuffered external reference, V <sub>eREF+</sub> = 2.5 V	3 V		±2	±5	
		SREF <sub>X</sub> = 011, buffered external reference <sup>(1)</sup> , V <sub>eREF+</sub> = 1.5 V	2.2 V		±2	±7	
		SREF <sub>X</sub> = 011, buffered external reference <sup>(1)</sup> , V <sub>eREF+</sub> = 2.5 V	3 V		±2	±6	

(1) The reference buffer offset adds to the gain and total unadjusted error.

## 10-Bit ADC, Temperature Sensor and Built-In V<sub>MID</sub> <sup>(1)</sup>

over recommended ranges of supply voltage and operating free-air temperature (unless otherwise noted)

PARAMETER		TEST CONDITIONS	V <sub>CC</sub>	MIN	TYP	MAX	UNIT
I <sub>SENSOR</sub>	Temperature sensor supply current <sup>(1)</sup>	REFON = 0, INCH <sub>X</sub> = 0Ah, T <sub>A</sub> = 25°C	2.2 V		40	120	μA
			3 V		60	160	
TC <sub>SENSOR</sub>		ADC10ON = 1, INCH <sub>X</sub> = 0Ah <sup>(2)</sup>	2.2 V, 3 V	3.44	3.55	3.66	mV/°C
V <sub>Offset, Sensor</sub>	Sensor offset voltage	ADC10ON = 1, INCH <sub>X</sub> = 0Ah <sup>(2)</sup>		-100		100	mV
V <sub>SENSOR</sub>	Sensor output voltage <sup>(3)</sup>	Temperature sensor voltage at T <sub>A</sub> = 105°C (T version only)	2.2 V, 3 V	1265	1365	1465	mV
		Temperature sensor voltage at T <sub>A</sub> = 85°C		1195	1295	1395	
		Temperature sensor voltage at T <sub>A</sub> = 25°C		985	1085	1185	
		Temperature sensor voltage at T <sub>A</sub> = 0°C		895	995	1095	
t <sub>SENSOR(sample)</sub>	Sample time required if channel 10 is selected <sup>(4)</sup>	ADC10ON = 1, INCH <sub>X</sub> = 0Ah, Error of conversion result ≤ 1 LSB	2.2 V, 3 V	30			μs
I <sub>VMID</sub>	Current into divider at channel 11 <sup>(4)</sup>	ADC10ON = 1, INCH <sub>X</sub> = 0Bh	2.2 V			N/A	μA
			3 V			N/A	
V <sub>MID</sub>	V <sub>CC</sub> divider at channel 11	ADC10ON = 1, INCH <sub>X</sub> = 0Bh, V <sub>MID</sub> ≈ 0.5 × V <sub>CC</sub>	2.2 V	1.06	1.1	1.14	V
			3 V	1.46	1.5	1.54	
t <sub>VMID(sample)</sub>	Sample time required if channel 11 is selected <sup>(5)</sup>	ADC10ON = 1, INCH <sub>X</sub> = 0Bh, Error of conversion result ≤ 1 LSB	2.2 V	1400			ns
			3 V	1220			

(1) The sensor current I<sub>SENSOR</sub> is consumed if (ADC10ON = 1 and REFON = 1), or (ADC10ON = 1 and INCH = 0Ah and sample signal is high). When REFON = 1, I<sub>SENSOR</sub> is included in I<sub>REF+</sub>. When REFON = 0, I<sub>SENSOR</sub> applies during conversion of the temperature sensor input (INCH = 0Ah).

(2) The following formula can be used to calculate the temperature sensor output voltage:

$$V_{\text{Sensor, typ}} = TC_{\text{Sensor}} (273 + T [^{\circ}\text{C}]) + V_{\text{Offset, sensor}} [\text{mV}] \text{ or}$$

$$V_{\text{Sensor, typ}} = TC_{\text{Sensor}} T [^{\circ}\text{C}] + V_{\text{Sensor}}(T_A = 0^{\circ}\text{C}) [\text{mV}]$$

(3) Results based on characterization and/or production test, not TC<sub>SENSOR</sub> or V<sub>Offset, sensor</sub>.

(4) No additional current is needed. The V<sub>MID</sub> is used during sampling.

(5) The on time, t<sub>VMID(on)</sub>, is included in the sampling time, t<sub>VMID(sample)</sub>; no additional on time is needed.

## Flash Memory

over recommended ranges of supply voltage and operating free-air temperature (unless otherwise noted)

PARAMETER		TEST CONDITIONS	V <sub>CC</sub>	MIN	TYP	MAX	UNIT
V <sub>CC (PGM/ERASE)</sub>	Program and erase supply voltage			2.2		3.6	V
f <sub>FTG</sub>	Flash timing generator frequency			257		476	kHz
I <sub>PGM</sub>	Supply current from V <sub>CC</sub> during program		2.2 V, 3.6 V		1	5	mA
I <sub>ERASE</sub>	Supply current from V <sub>CC</sub> during erase		2.2 V, 3.6 V		1	7	mA
t <sub>CPT</sub>	Cumulative program time <sup>(1)</sup>		2.2 V, 3.6 V			10	ms
t <sub>CMErase</sub>	Cumulative mass erase time		2.2 V, 3.6 V	20			ms
	Program/Erase endurance			10 <sup>4</sup>	10 <sup>5</sup>		cycles
t <sub>Retention</sub>	Data retention duration	T <sub>J</sub> = 25°C		15			years
t <sub>Word</sub>	Word or byte program time	(2)			30		t <sub>FTG</sub>
t <sub>Block, 0</sub>	Block program time for first byte or word	(2)			25		t <sub>FTG</sub>
t <sub>Block, 1-63</sub>	Block program time for each additional byte or word	(2)			18		t <sub>FTG</sub>
t <sub>Block, End</sub>	Block program end-sequence wait time	(2)			6		t <sub>FTG</sub>
t <sub>Mass Erase</sub>	Mass erase time	(2)			10593		t <sub>FTG</sub>
t <sub>Seg Erase</sub>	Segment erase time	(2)			4819		t <sub>FTG</sub>

- (1) The cumulative program time must not be exceeded when writing to a 64-byte flash block. This parameter applies to all programming methods: individual word/byte write and block write modes.
- (2) These values are hardwired into the flash controller's state machine (t<sub>FTG</sub> = 1/f<sub>FTG</sub>).

## RAM

over recommended ranges of supply voltage and operating free-air temperature (unless otherwise noted)

PARAMETER		TEST CONDITIONS	MIN	MAX	UNIT
V <sub>(RAMh)</sub>	RAM retention supply voltage <sup>(1)</sup>	CPU halted	1.6		V

- (1) This parameter defines the minimum supply voltage V<sub>CC</sub> when the data in RAM remains unchanged. No program execution should happen during this supply voltage condition.

## JTAG and Spy-Bi-Wire Interface

over recommended ranges of supply voltage and operating free-air temperature (unless otherwise noted)

PARAMETER		TEST CONDITIONS	V <sub>CC</sub>	MIN	TYP	MAX	UNIT
f <sub>SBW</sub>	Spy-Bi-Wire input frequency		2.2 V, 3 V	0		20	MHz
t <sub>SBW,Low</sub>	Spy-Bi-Wire low clock pulse length		2.2 V, 3 V	0.025		15	μs
t <sub>SBW,En</sub>	Spy-Bi-Wire enable time (TEST high to acceptance of first clock edge <sup>(1)</sup> )		2.2 V, 3 V			1	μs
t <sub>SBW,Ret</sub>	Spy-Bi-Wire return to normal operation time		2.2 V, 3 V	15		100	μs
f <sub>TCK</sub>	TCK input frequency <sup>(2)</sup>		2.2 V	0		5	MHz
			3 V	0		10	MHz
R <sub>Internal</sub>	Internal pulldown resistance on TEST		2.2 V, 3 V	25	60	90	kΩ

- (1) Tools accessing the Spy-Bi-Wire interface need to wait for the maximum t<sub>SBW,En</sub> time after pulling the TEST/SBWCLK pin high before applying the first SBWCLK clock edge.
- (2) f<sub>TCK</sub> may be restricted to meet the timing requirements of the module selected.

## JTAG Fuse<sup>(1)</sup>

over recommended ranges of supply voltage and operating free-air temperature (unless otherwise noted)

PARAMETER		TEST CONDITIONS	MIN	MAX	UNIT
V <sub>CC(FB)</sub>	Supply voltage during fuse-blow condition	T <sub>A</sub> = 25°C	2.5		V
V <sub>FB</sub>	Voltage level on TEST for fuse blow		6	7	V
I <sub>FB</sub>	Supply current into TEST during fuse blow			100	mA
t <sub>FB</sub>	Time to blow fuse			1	ms

- (1) Once the fuse is blown, no further access to the JTAG/Test, Spy-Bi-Wire, and emulation feature is possible, and JTAG is switched to bypass mode.

### Application Information

#### Port P1 Pin Schematic: P1.0 to P1.3, Input/Output With Schmitt Trigger

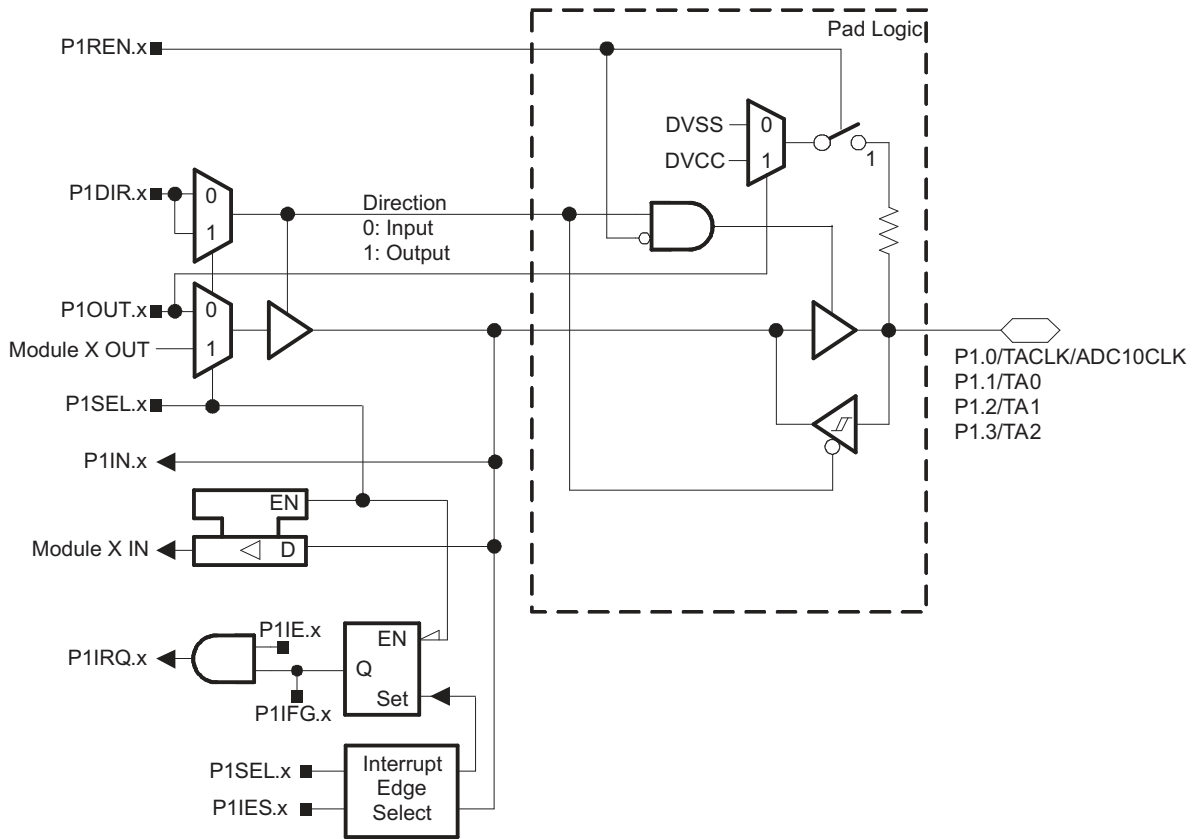
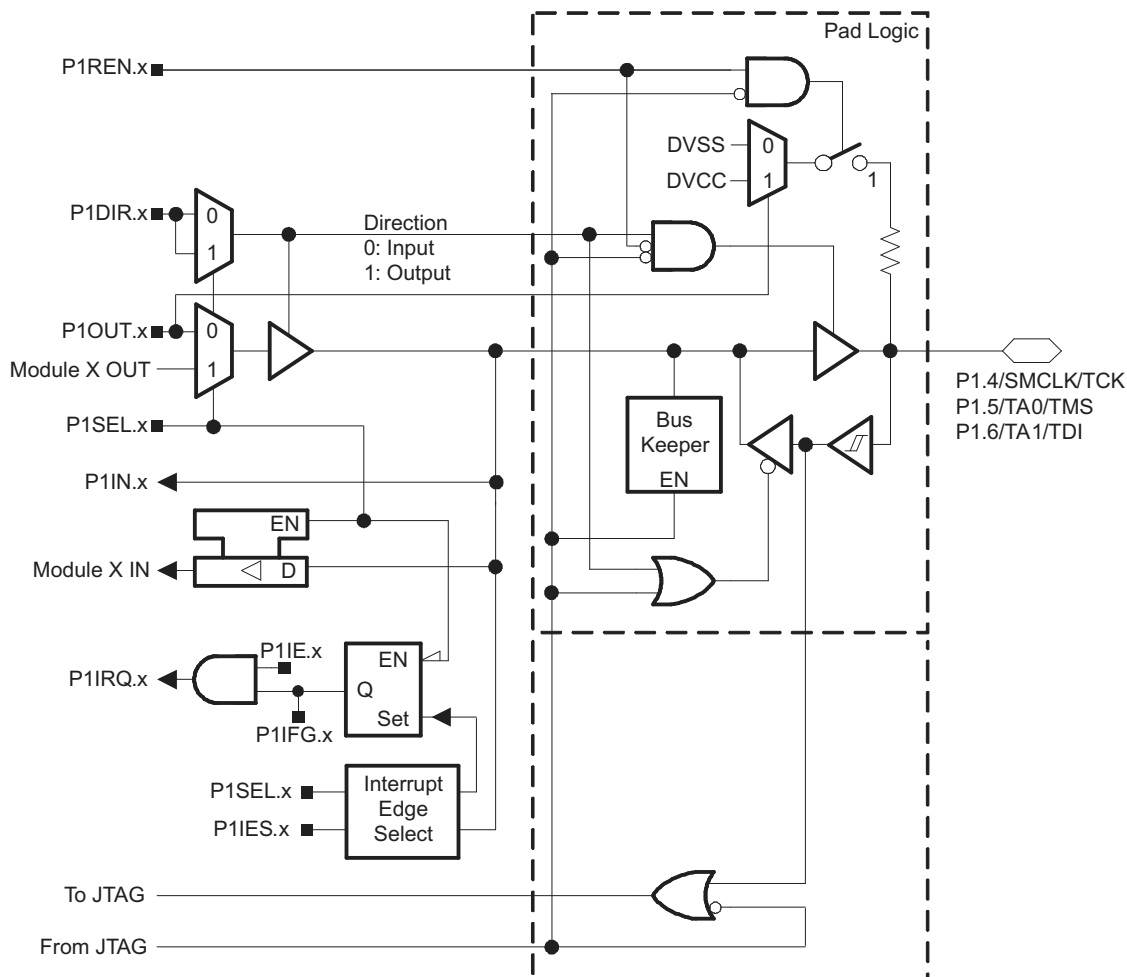

**Table 16. Port P1 (P1.0 to P1.3) Pin Functions**

PIN NAME (P1.x)	x	FUNCTION	CONTROL BITS/SIGNALS	
			P1DIR.x	P1SEL.x
P1.0/TACLK/ADC10CLK	0	P1.0 <sup>(1)</sup>	I: 0; O: 1	0
		Timer_A3.TACLK	0	1
		ADC10CLK	1	1
P1.1/TA0	1	P1.1 <sup>(1)</sup> (I/O)	I: 0; O: 1	0
		Timer_A3.CCI0A	0	1
		Timer_A3.TA0	1	1
P1.2/TA1	2	P1.2 <sup>(1)</sup> (I/O)	I: 0; O: 1	0
		Timer_A3.CCI1A	0	1
		Timer_A3.TA1	1	1
P1.3/TA2	3	P1.3 <sup>(1)</sup> (I/O)	I: 0; O: 1	0
		Timer_A3.CCI2A	0	1
		Timer_A3.TA2	1	1

(1) Default after reset (PUC/POR)

**Port P1 Pin Schematic: P1.4 to P1.6, Input/Output With Schmitt Trigger and In-System Access Features**

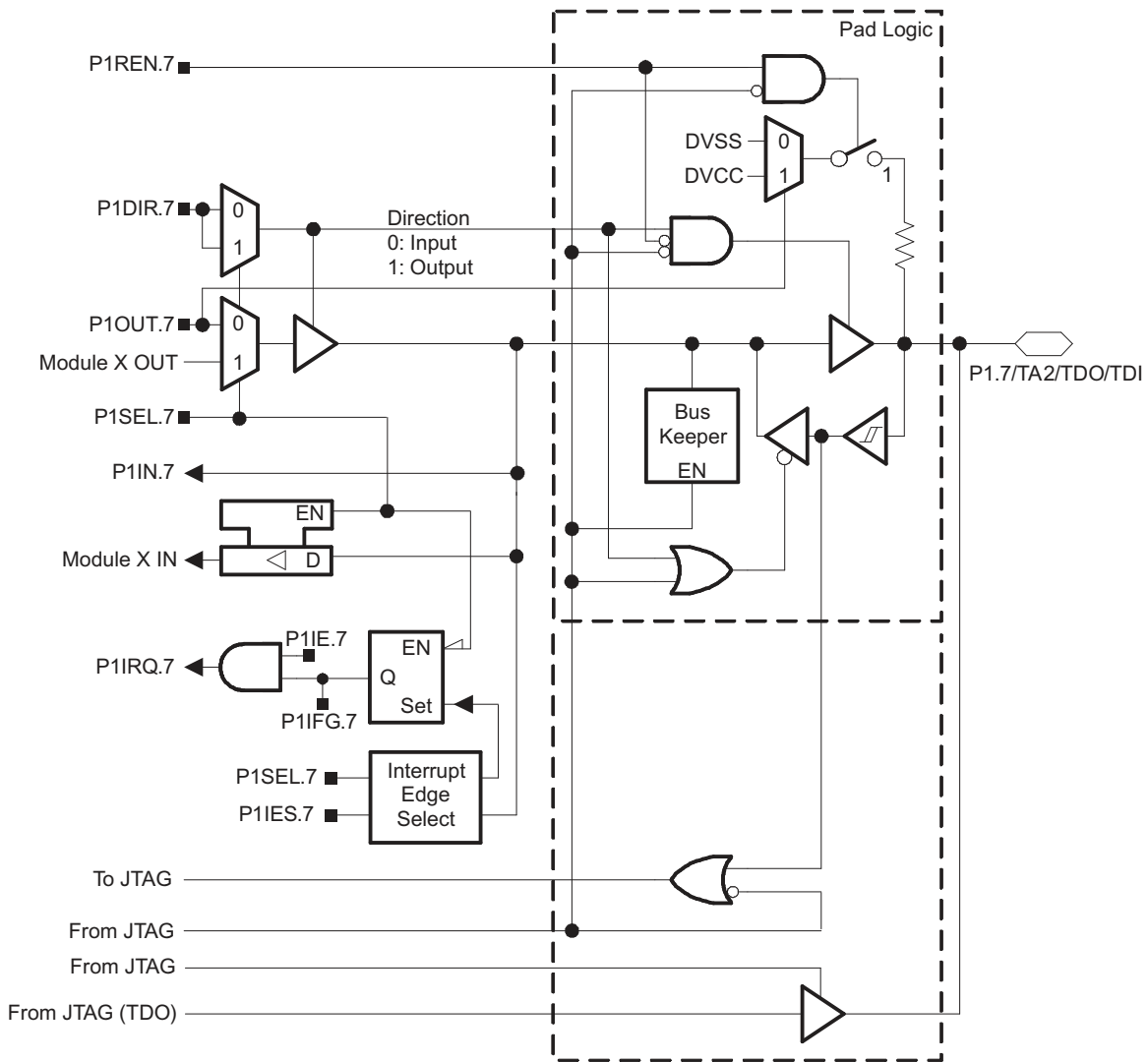

**Table 17. Port P1 (P1.4 to P1.6) Pin Functions**

PIN NAME (P1.x)	x	FUNCTION	CONTROL BITS/SIGNALS <sup>(1)</sup>		
			P1DIR.x	P1SEL.x	4-Wire JTAG
P1.4/SMCLK/TCK	4	P1.4 <sup>(2)</sup> (I/O)	I: 0; O: 1	0	0
		SMCLK	1	1	0
		TCK	X	X	1
P1.5/TA0/TMS	5	P1.5 <sup>(2)</sup> (I/O)	I: 0; O: 1	0	0
		Timer_A3.TA0	1	1	0
		TMS	X	X	1
P1.6/TA1/TDI/TCLK	6	P1.6 <sup>(2)</sup> (I/O)	I: 0; O: 1	0	0
		Timer_A3.TA1	1	1	0
		TDI/TCLK <sup>(3)</sup>	X	X	1

(1) X = Don't care  
 (2) Default after reset (PUC/POR)  
 (3) Function controlled by JTAG

**Port P1 Pin Schematic: P1.7, Input/Output With Schmitt Trigger and In-System Access Features**



**Table 18. Port P1 (P1.7) Pin Functions**

PIN NAME (P1.x)	x	FUNCTION	CONTROL BITS/SIGNALS <sup>(1)</sup>		
			P1DIR.x	P1SEL.x	4-Wire JTAG
P1.7/TA2/TDO/TDI	7	P1.7 <sup>(2)</sup> (I/O)	I: 0; O: 1	0	0
		Timer_A3.TA2	1	1	0
		TDO/TDI <sup>(3)</sup>	X	X	1

(1) X = Don't care  
 (2) Default after reset (PUC/POR)  
 (3) Function controlled by JTAG



Port P2 Pin Schematic: P2.0, P2.2, Input/Output With Schmitt Trigger

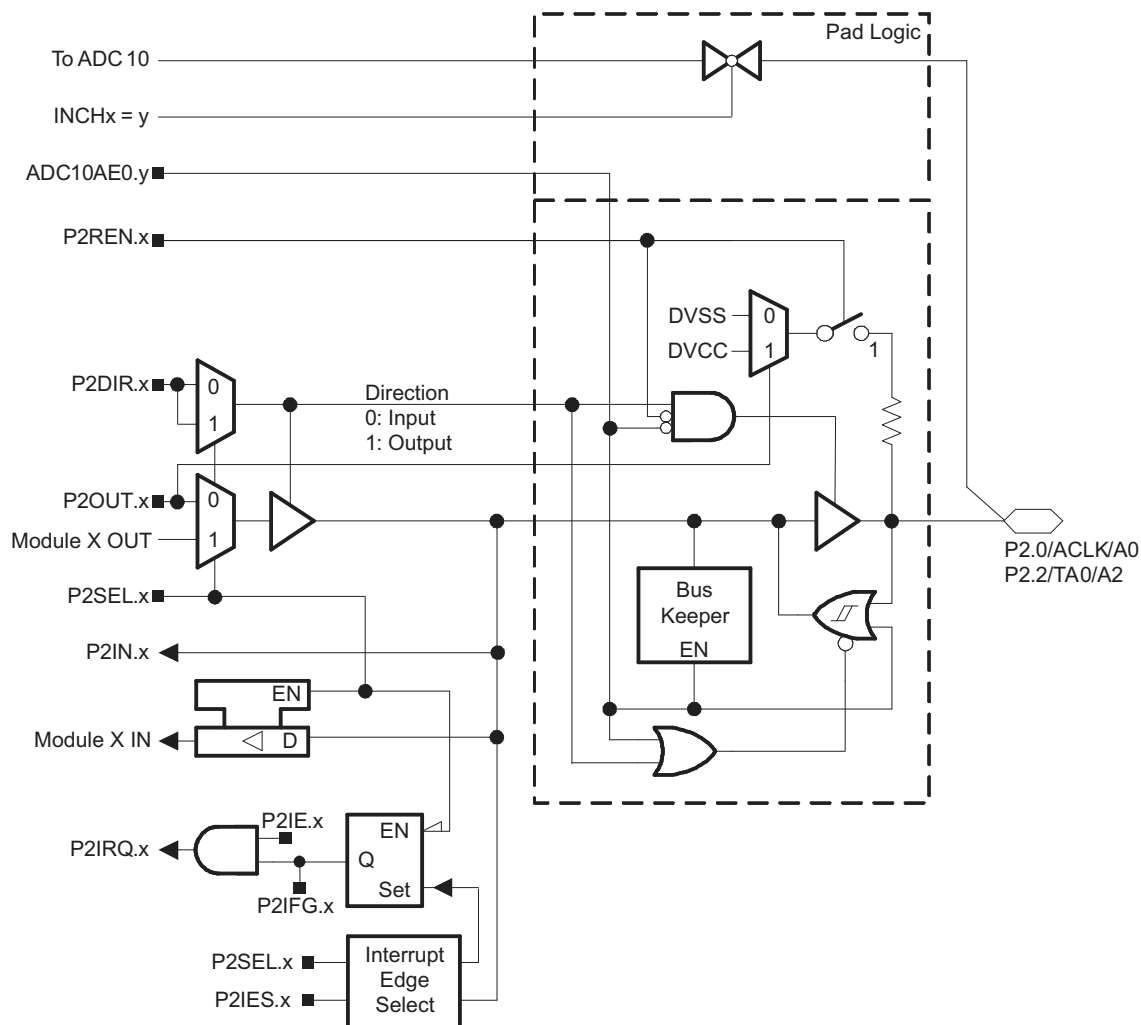
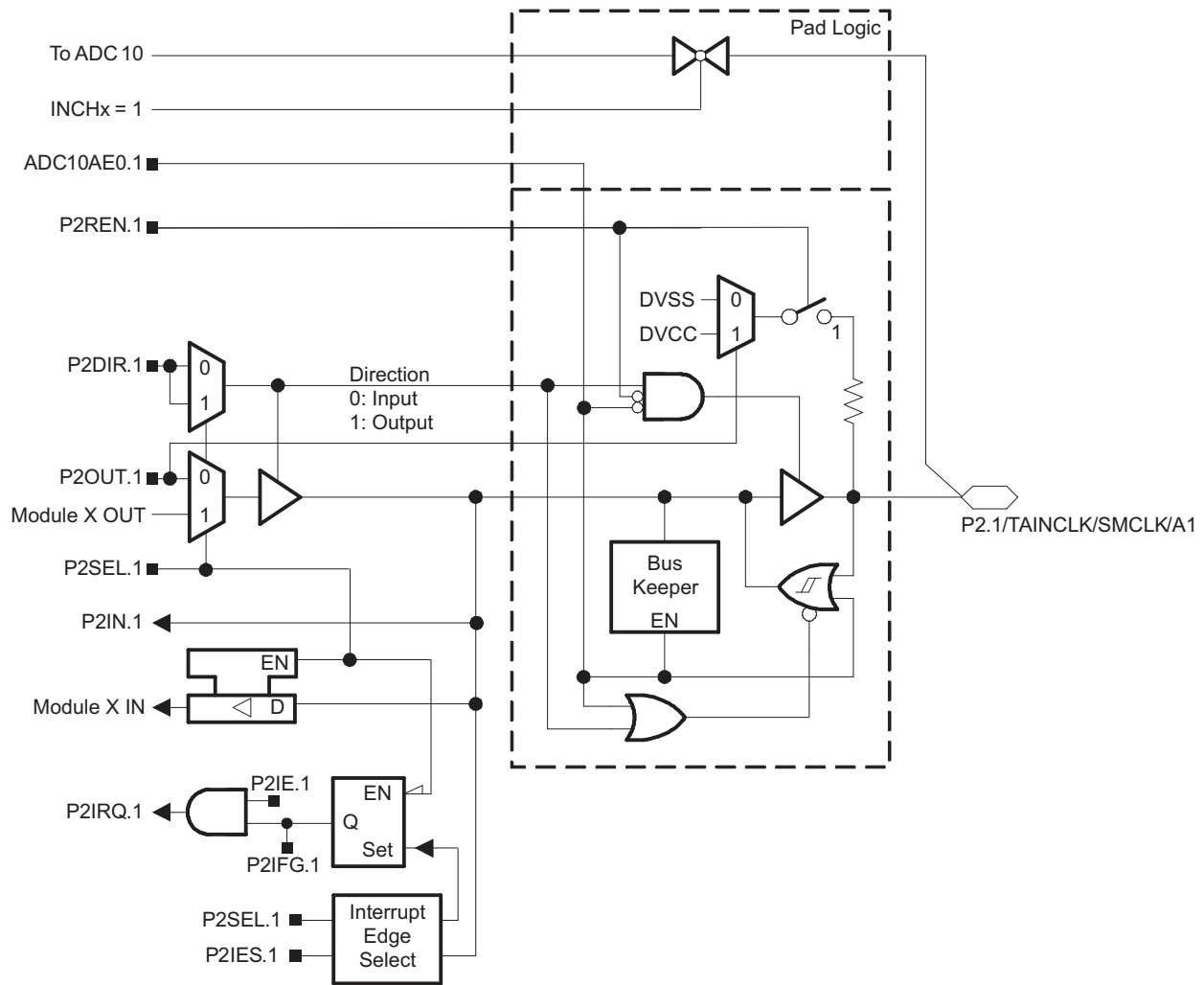

Table 19. Port P2 (P2.0, P2.2) Pin Functions

Pin Name (P2.x)	x	y	FUNCTION	CONTROL BITS/SIGNALS <sup>(1)</sup>		
				P2DIR.x	P2SEL.x	ADC10AE0.y
P2.0/ACLK/A0	0	0	P2.0 <sup>(2)</sup> (I/O)	I: 0; O: 1	0	0
			ACLK	1	1	0
			A0 <sup>(3)</sup>	X	X	1
P2.2/TA0/A2	2	2	P2.2 <sup>(2)</sup> (I/O)	I: 0; O: 1	0	0
			Timer_A3.CCI0B	0	1	0
			Timer_A3.TA0	1	1	0
			A2 <sup>(3)</sup>	X	X	1

- (1) X = Don't care
- (2) Default after reset (PUC/POR)
- (3) Setting the ADC10AE0.y bit disables the output driver as well as the input Schmitt trigger to prevent parasitic cross currents when applying analog signals.

**Port P2 Pin Schematic: P2.1, Input/Output With Schmitt Trigger**



**Table 20. Port P2 (P2.1) Pin Functions**

PIN NAME (P2.x)	x	y	FUNCTION	CONTROL BITS/SIGNALS <sup>(1)</sup>		
				P2DIR.x	P2SEL.x	ADC10AE0.y
P2.1/TAINCLK/SMCLK/A1	1	1	P2.1 <sup>(2)</sup> (I/O)	I: 0; O: 1	0	0
			Timer_A3.INCLK	0	1	0
			SMCLK	1	1	0
			A1 <sup>(3)</sup>	X	X	1

- (1) X = Don't care
- (2) Default after reset (PUC/POR)
- (3) Setting the ADC10AE0.y bit disables the output driver as well as the input Schmitt trigger to prevent parasitic cross currents when applying analog signals.

Port P2 Pin Schematic: P2.3, Input/Output With Schmitt Trigger

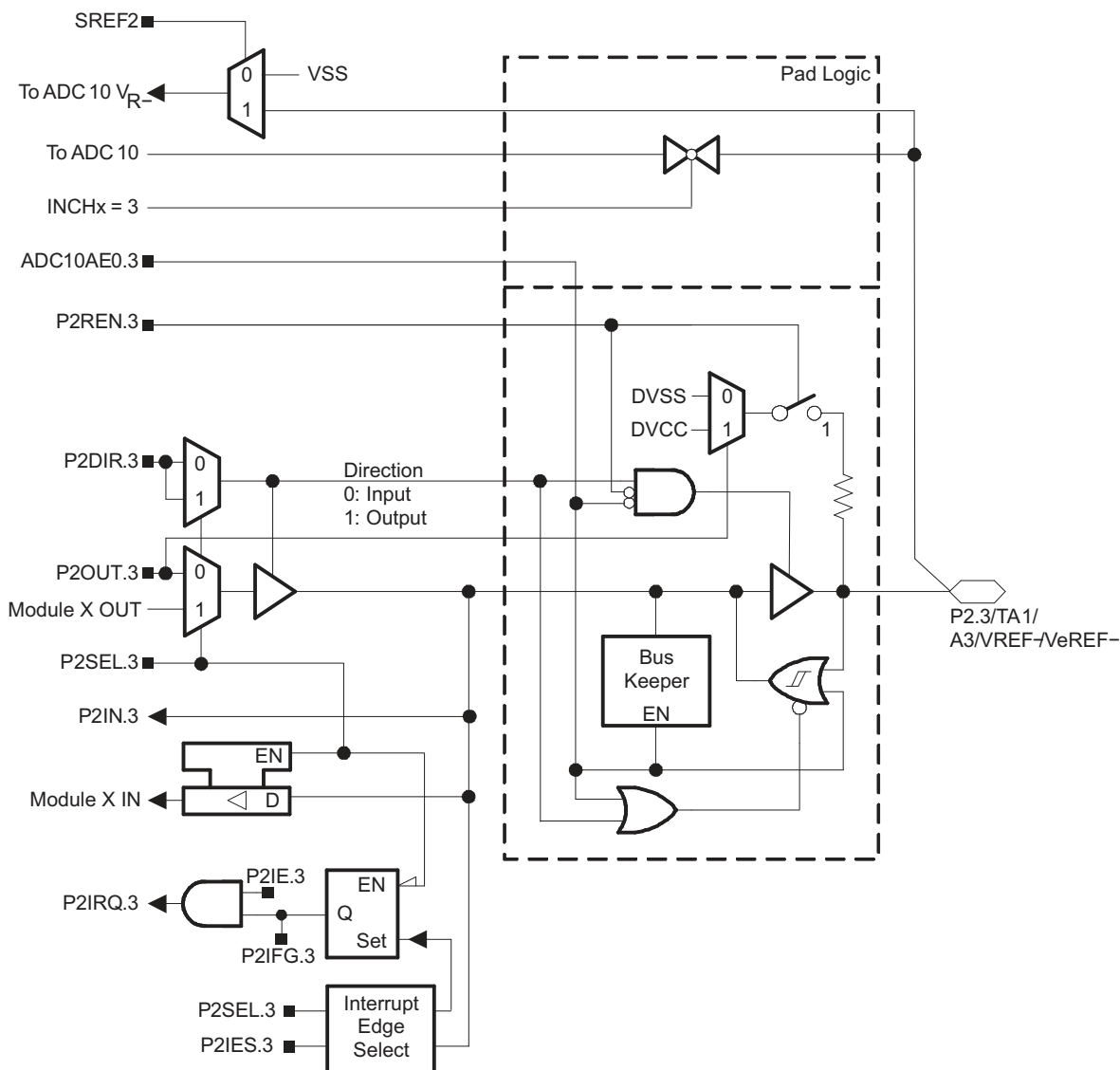
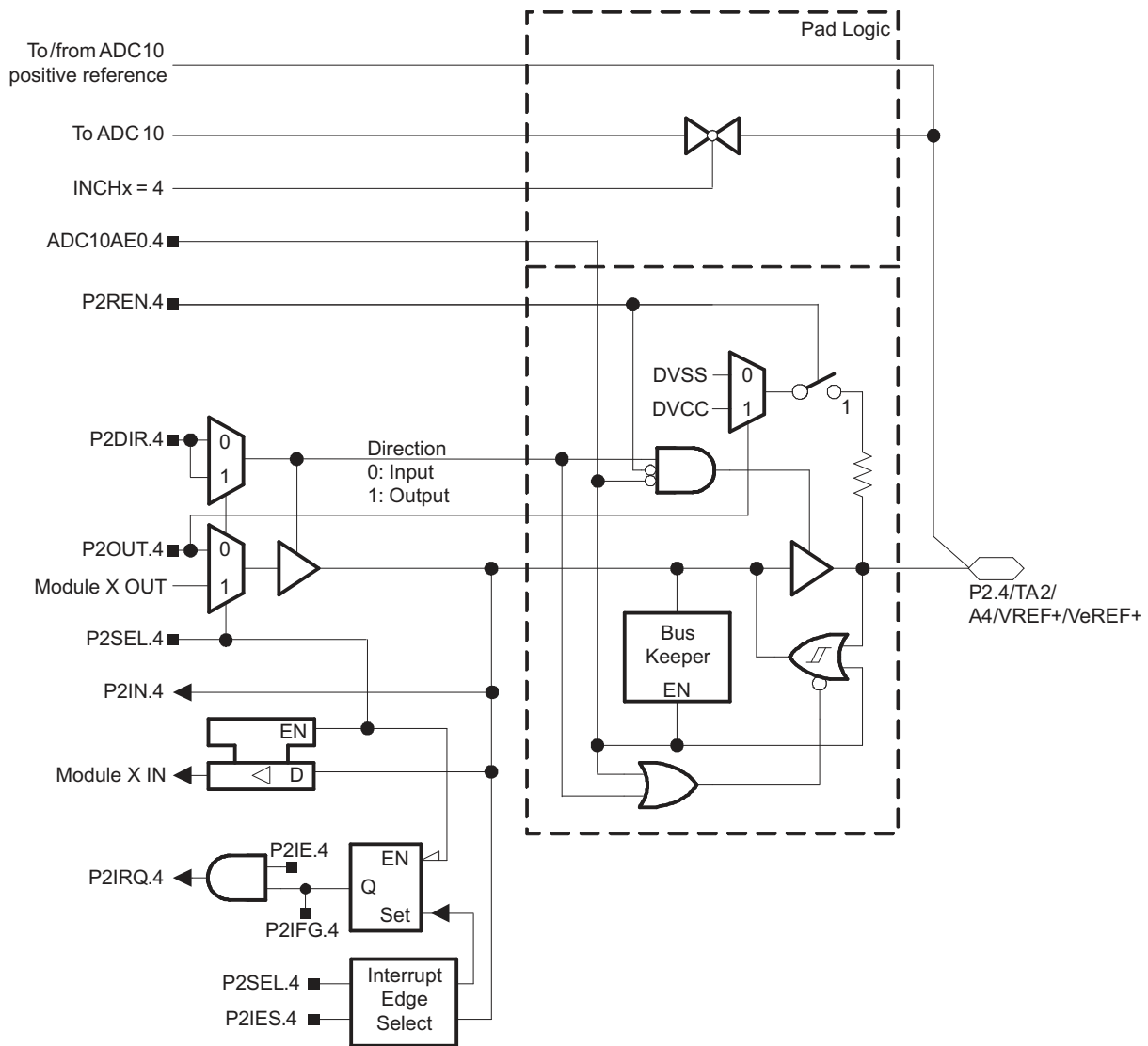

Table 21. Port P2 (P2.3) Pin Functions

PIN NAME (P2.x)	x	y	FUNCTION	CONTROL BITS/SIGNALS <sup>(1)</sup>		
				P2DIR.x	P2SEL.x	ADC10AE0.y
P2.3/TA1/A3/V <sub>REF-</sub> /V <sub>e</sub> REF-	3	3	P2.3 <sup>(2)</sup> (I/O)	I: 0; O: 1	0	0
			Timer_A3.CCI1B	0	1	0
			Timer_A3.TA1	1	1	0
			A3/V <sub>REF-</sub> /V <sub>e</sub> REF- <sup>(3)</sup>	X	X	1

- (1) X = Don't care
- (2) Default after reset (PUC/POR)
- (3) Setting the ADC10AE0.y bit disables the output driver as well as the input Schmitt trigger to prevent parasitic cross currents when applying analog signals.

**Port P2 Pin Schematic: P2.4, Input/Output With Schmitt Trigger**



**Table 22. Port P2 (P2.4) Pin Functions**

PIN NAME (P2.x)	x	y	FUNCTION	CONTROL BITS/SIGNALS <sup>(1)</sup>		
				P2DIR.x	P2SEL.x	ADC10AE0.y
P2.4/TA2/A4/V <sub>REF+</sub> / V <sub>eREF+</sub>	4	4	P2.4 <sup>(2)</sup> (I/O)	I: 0; O: 1	0	0
			Timer_A3.TA2	1	1	0
			A4/V <sub>REF+</sub> /V <sub>eREF+</sub> <sup>(3)</sup>	X	X	1

- (1) X = Don't care
- (2) Default after reset (PUC/POR)
- (3) Setting the ADC10AE0.y bit disables the output driver as well as the input Schmitt trigger to prevent parasitic cross currents when applying analog signals.

Port P2 Pin Schematic: P2.5, Input/Output With Schmitt Trigger and External R<sub>OSC</sub> for DCO

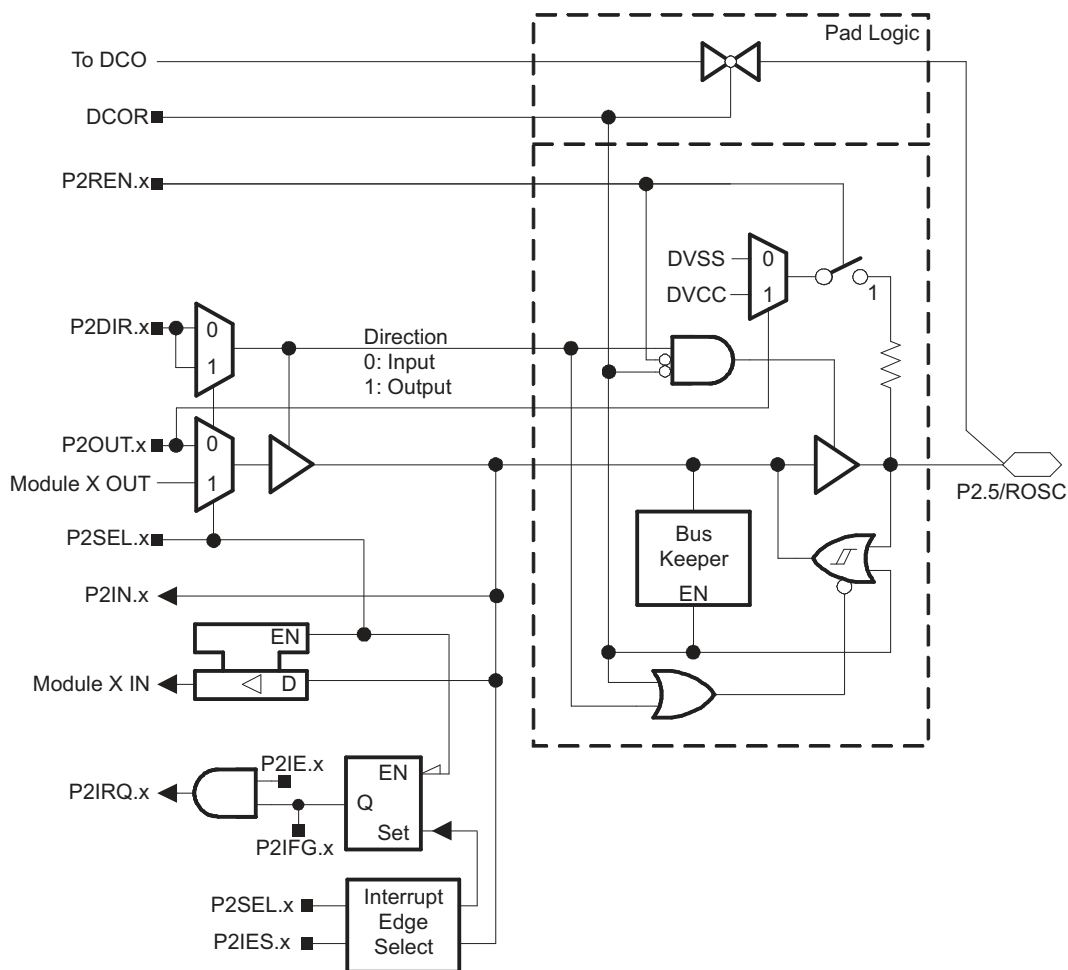
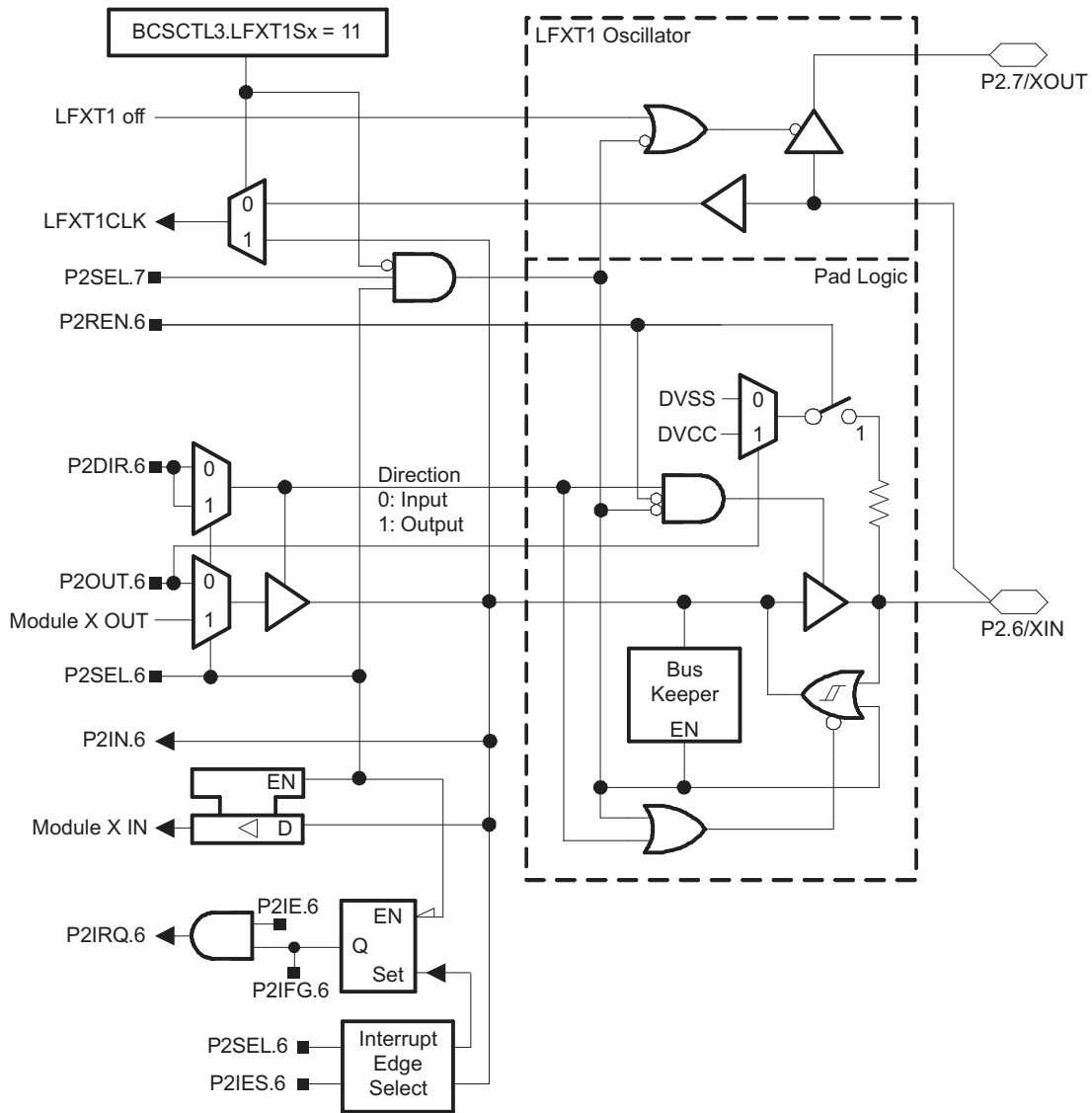

Table 23. Port P2 (P2.5) Pin Functions

PIN NAME (P2.x)	x	FUNCTION	CONTROL BITS/SIGNALS <sup>(1)</sup>		
			P2DIR.x	P2SEL.x	DCOR
P2.5/R <sub>OSC</sub>	5	P2.5 <sup>(2)</sup> (I/O)	I: 0; O: 1	0	0
		N/A <sup>(3)</sup>	0	1	0
		DV <sub>SS</sub>	1	1	0
		R <sub>OSC</sub>	X	X	1

- (1) X = Don't care
- (2) Default after reset (PUC/POR)
- (3) N/A = Not available or not applicable

**Port P2 Pin Schematic: P2.6, Input/Output With Schmitt Trigger and Crystal Oscillator Input**



**Table 24. Port P2 (P2.6) Pin Functions**

PIN NAME (P2.x)	x	FUNCTION	CONTROL BITS/SIGNALS <sup>(1)</sup>	
			P2DIR.x	P2SEL.x
P2.6/XIN	6	P2.6 (I/O)	I: 0; O: 1	0
		XIN <sup>(2)</sup>	X	1

(1) X = Don't care  
 (2) Default after reset (PUC/POR)

Port P2 Pin Schematic: P2.7, Input/Output With Schmitt Trigger and Crystal Oscillator Output

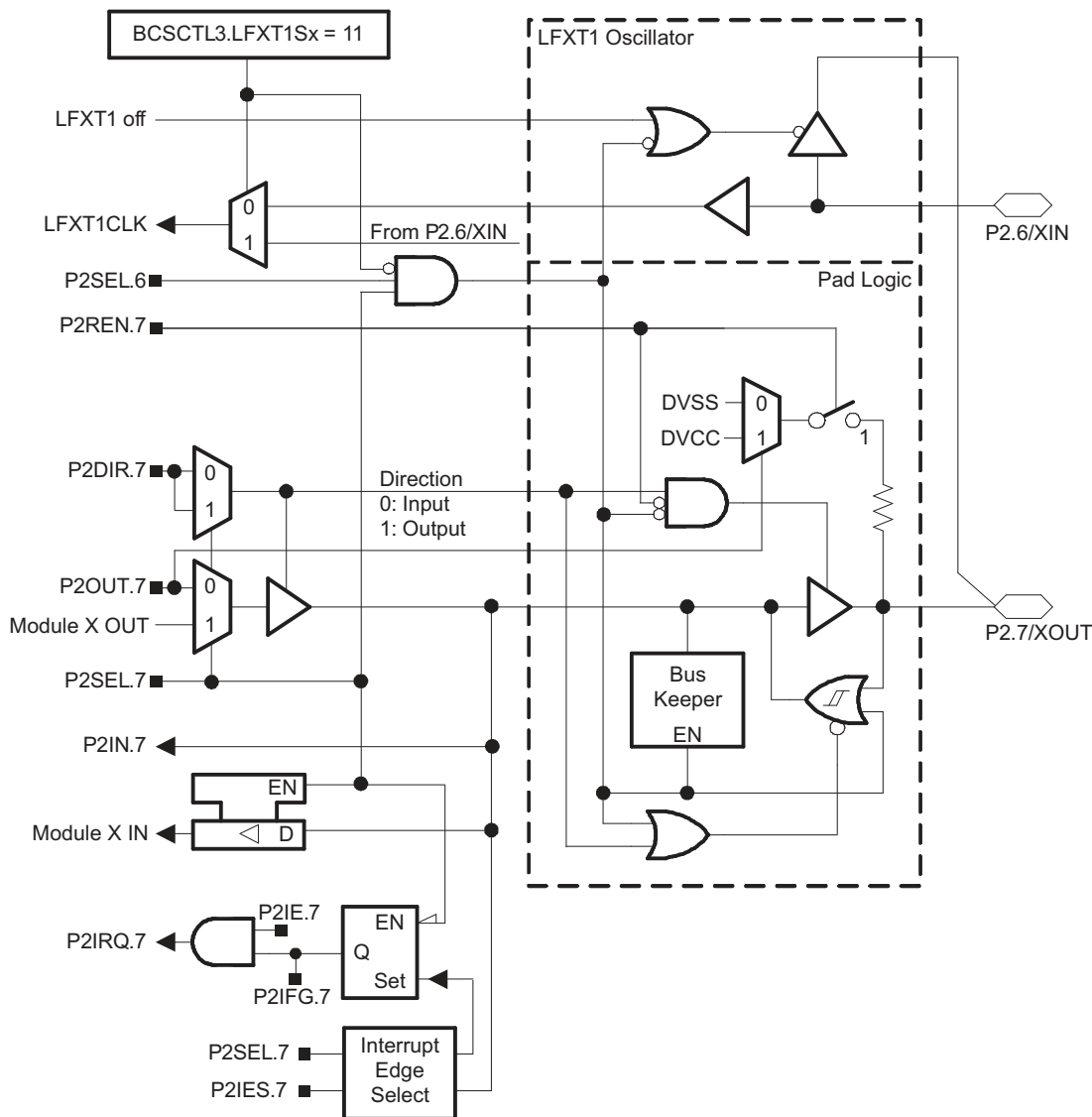

Table 25. Port P2 (P2.7) Pin Functions

PIN NAME (P2.x)	x	FUNCTION	CONTROL BITS/SIGNALS <sup>(1)</sup>	
			P2DIR.x	P2SEL.x
XOUT/P2.7	7	P2.7 (I/O)	I: 0; O: 1	0
		XOUT <sup>(2) (3)</sup>	X	1

(1) X = Don't care

(2) Default after reset (PUC/POR)

(3) If the pin XOUT/P2.7 is used as an input a current can flow until P2SEL.7 is cleared due to the oscillator output driver connection to this pin after reset.

**Port P3 Pin Schematic: P3.0, Input/Output With Schmitt Trigger**

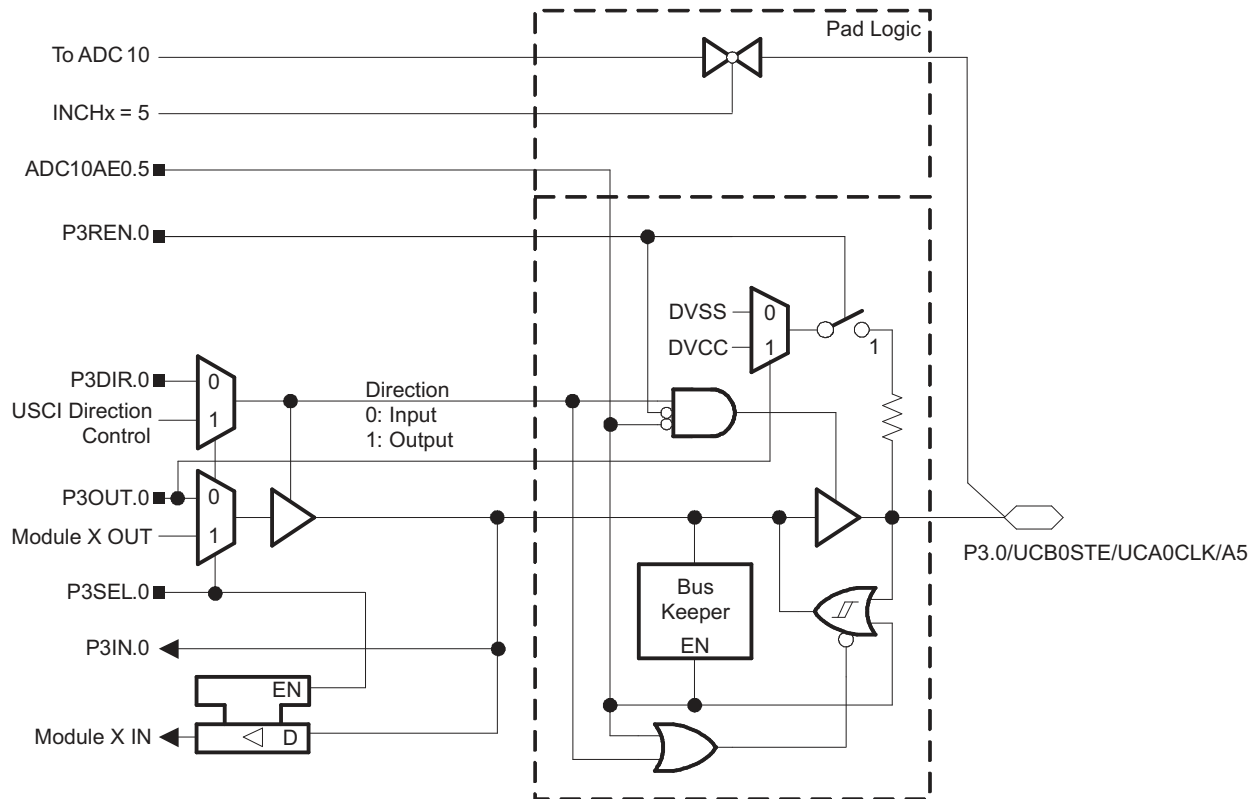

**Table 26. Port P3 (P3.0) Pin Functions**

PIN NAME (P1.x)	x	y	FUNCTION	CONTROL BITS/SIGNALS <sup>(1)</sup>		
				P3DIR.x	P3SEL.x	ADC10AE0.y
P3.0/UCB0STE/ UCA0CLK/A5	0	5	P3.0 <sup>(2)</sup> (I/O)	I: 0; O: 1	0	0
			UCB0STE/UCA0CLK <sup>(3) (4)</sup>	X	1	0
			A5 <sup>(5)</sup>	X	X	1

- (1) X = Don't care
- (2) Default after reset (PUC/POR)
- (3) The pin direction is controlled by the USCI module.
- (4) UCA0CLK function takes precedence over UCB0STE function. If the pin is required as UCA0CLK input or output, USCI\_B0 is forced to 3-wire SPI mode if 4-wire SPI mode is selected.
- (5) Setting the ADC10AE0.y bit disables the output driver as well as the input Schmitt trigger to prevent parasitic cross currents when applying analog signals.



Port P3 Pin Schematic: P3.1 to P3.5, Input/Output With Schmitt Trigger

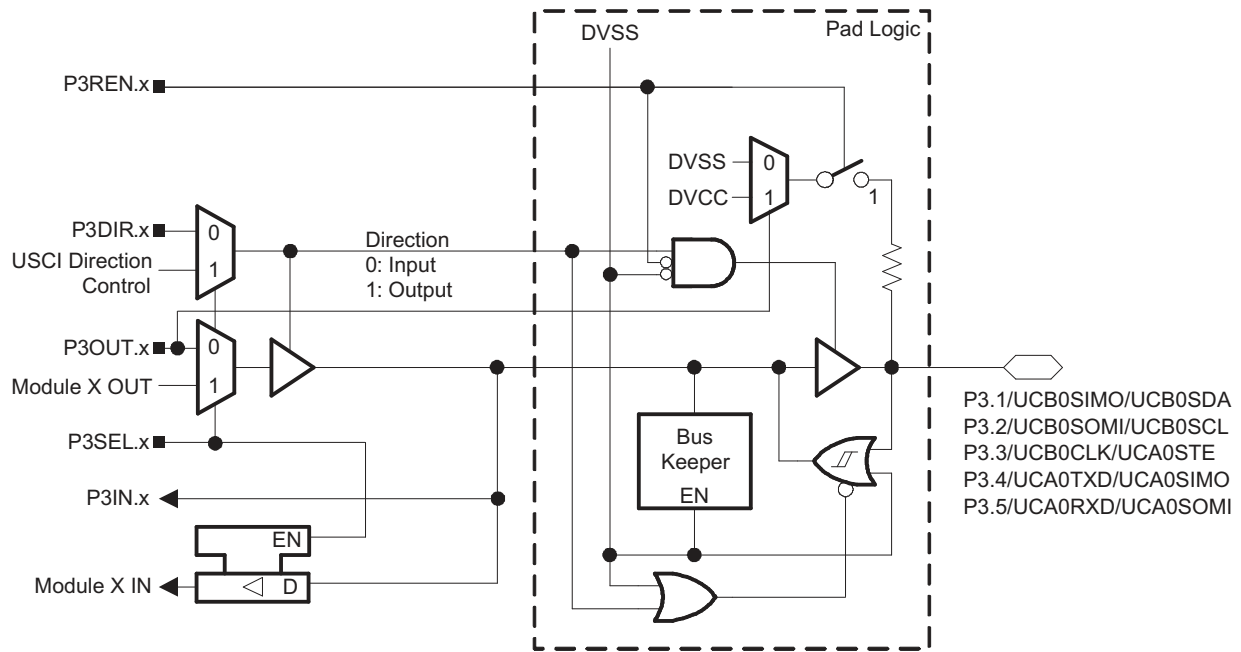
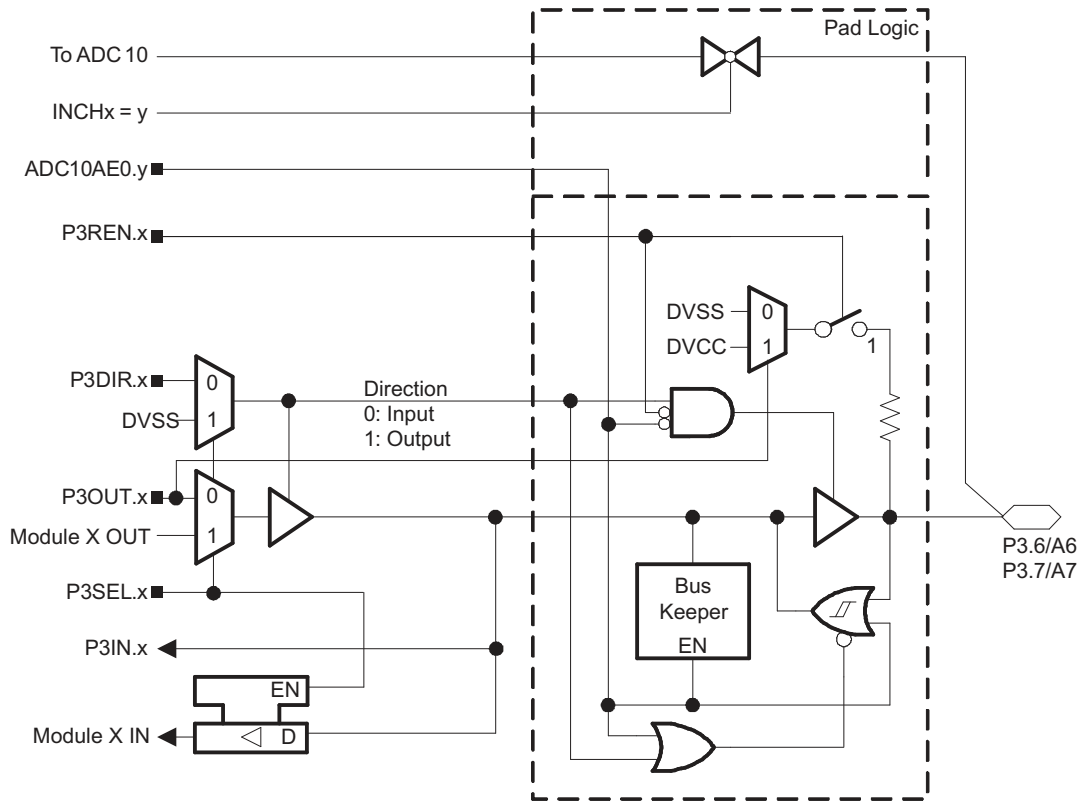

Table 27. Port P3 (P3.1 to P3.5) Pin Functions

PIN NAME (P3.x)	x	FUNCTION	CONTROL BITS/SIGNALS <sup>(1)</sup>	
			P3DIR.x	P3SEL.x
P3.1/UCB0SIMO/UCB0SDA	1	P3.1 <sup>(2)</sup> (I/O)	I: 0; O: 1	0
		UCB0SIMO/UCB0SDA <sup>(3)</sup>	X	1
P3.2/UCB0SOMI/UCB0SCL	2	P3.2 <sup>(2)</sup> (I/O)	I: 0; O: 1	0
		UCB0SOMI/UCB0SCL <sup>(3)</sup>	X	1
P3.3/UCB0CLK/UCA0STE	3	P3.3 <sup>(2)</sup> (I/O)	I: 0; O: 1	0
		UCB0CLK/UCA0STE <sup>(3) (4)</sup>	X	1
P3.4/UCA0TXD/UCA0SIMO	4	P3.4 <sup>(2)</sup> (I/O)	I: 0; O: 1	0
		UCA0TXD/UCA0SIMO <sup>(3)</sup>	X	1
P3.5/UCA0RXD/UCA0SOMI	5	P3.5 <sup>(2)</sup> (I/O)	I: 0; O: 1	0
		UCA0RXD/UCA0SOMI <sup>(3)</sup>	X	1

- (1) X = Don't care
- (2) Default after reset (PUC/POR)
- (3) The pin direction is controlled by the USC1 module.
- (4) UCB0CLK function takes precedence over UCA0STE function. If the pin is required as UCB0CLK input or output, USC1\_A0 is forced to 3-wire SPI mode even if 4-wire SPI mode is selected.

**Port P3 Pin Schematic: P3.6 to P3.7, Input/Output With Schmitt Trigger**



**Table 28. Port P3 (P3.6, P3.7) Pin Functions**

PIN NAME (P3.x)	x	y	FUNCTION	CONTROL BITS/SIGNALS <sup>(1)</sup>		
				P3DIR.x	P3SEL.x	ADC10AE0.y
P3.6/A6	6	6	P3.6 <sup>(2)</sup> (I/O)	I: 0; O: 1	0	0
			A6 <sup>(3)</sup>	X	X	1
P3.7/A7	7	7	P3.7 <sup>(2)</sup> (I/O)	I: 0; O: 1	0	0
			A7 <sup>(3)</sup>	X	X	1

- (1) X = Don't care
- (2) Default after reset (PUC/POR)
- (3) Setting the ADC10AE0.y bit disables the output driver as well as the input Schmitt trigger to prevent parasitic cross currents when applying analog signals.

Port P4 Pin Schematic: P4.0 to P4.2, Input/Output With Schmitt Trigger

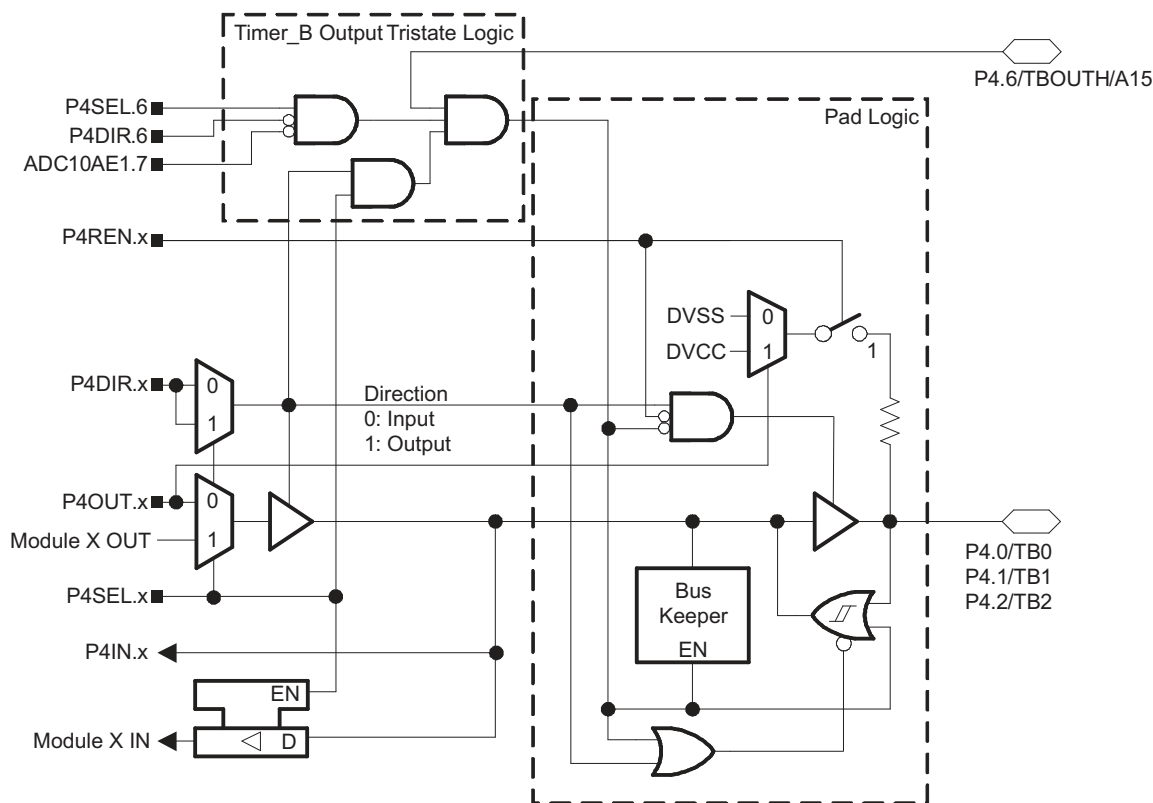
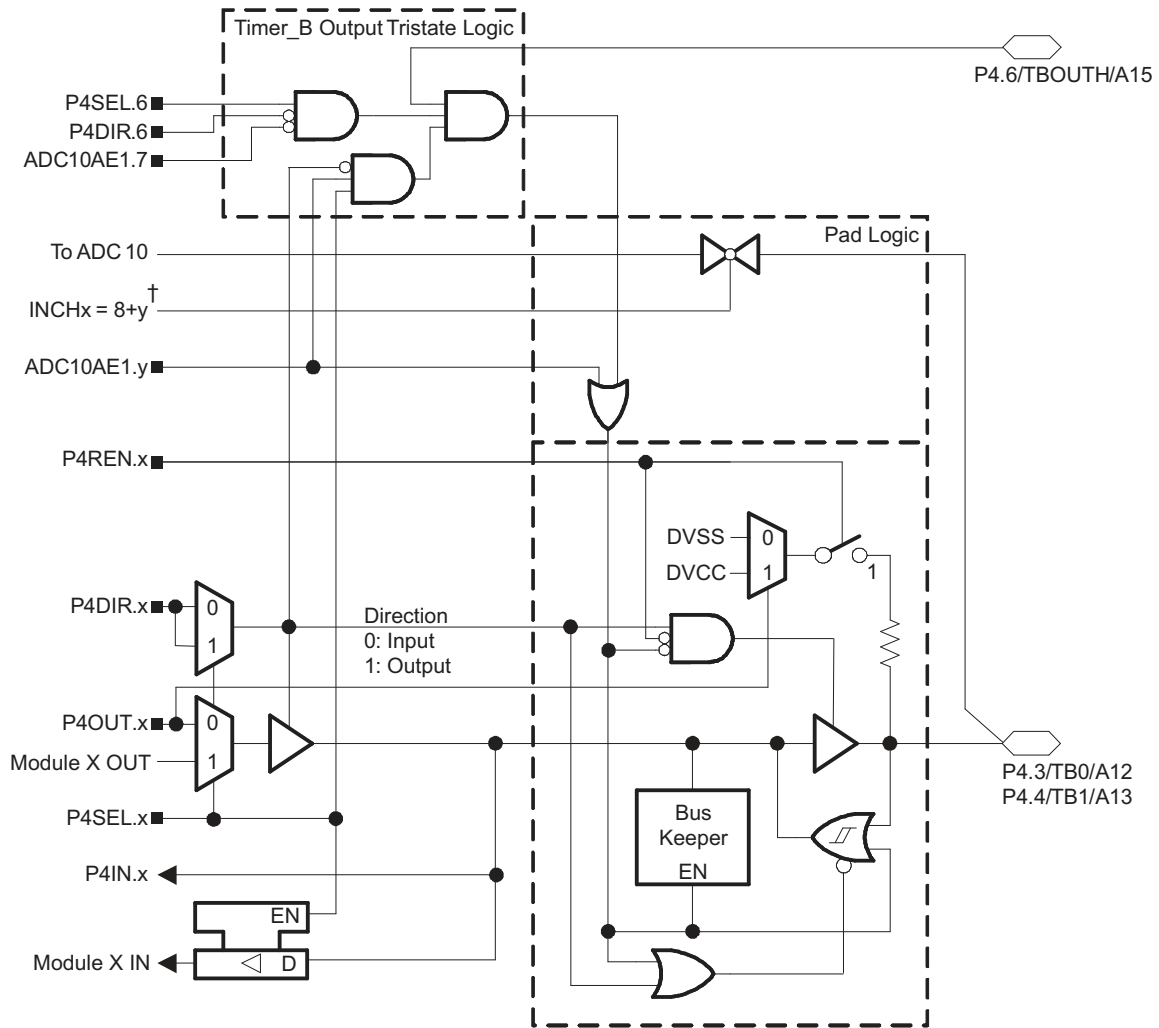

Table 29. Port P4 (P4.0 to P4.2) Pin Functions

PIN NAME (P4.x)	x	FUNCTION	CONTROL BITS/SIGNALS	
			P4DIR.x	P4SEL.x
P4.0/TB0	0	P4.0 <sup>(1)</sup> (I/O)	I: 0; O: 1	0
		Timer_B3.CCI0A	0	1
		Timer_B3.TB0	1	1
P4.1/TB1	1	P4.1 <sup>(1)</sup> (I/O)	I: 0; O: 1	0
		Timer_B3.CCI1A	0	1
		Timer_B3.TB1	1	1
P4.2/TB2	2	P4.2 <sup>(1)</sup> (I/O)	I: 0; O: 1	0
		Timer_B3.CCI2A	0	1
		Timer_B3.TB2	1	1

(1) Default after reset (PUC/POR)

**Port P4 Pin Schematic: P4.3 to P4.4, Input/Output With Schmitt Trigger**



**Table 30. Port P4 (P4.3 to P4.4) Pin Functions**

PIN NAME (P4.x)	x	y	FUNCTION	CONTROL BITS/SIGNALS <sup>(1)</sup>		
				P4DIR.x	P4SEL.x	ADC10AE1.y
P4.3/TB0/A12	3	4	P4.3 <sup>(2)</sup> (I/O)	I: 0; O: 1	0	0
			Timer_B3.CCI0B	0	1	0
			Timer_B3.TB0	1	1	0
			A12 <sup>(3)</sup>	X	X	1
P4.4/TB1/A13	4	5	P4.4 <sup>(2)</sup> (I/O)	I: 0; O: 1	0	0
			Timer_B3.CCI1B	0	1	0
			Timer_B3.TB1	1	1	0
			A13 <sup>(3)</sup>	X	X	1

(1) X = Don't care

(2) Default after reset (PUC/POR)

(3) Setting the ADC10AE1.y bit disables the output driver as well as the input Schmitt trigger to prevent parasitic cross currents when applying analog signals.

**Port P4 Pin Schematic: P4.5, Input/Output With Schmitt Trigger**

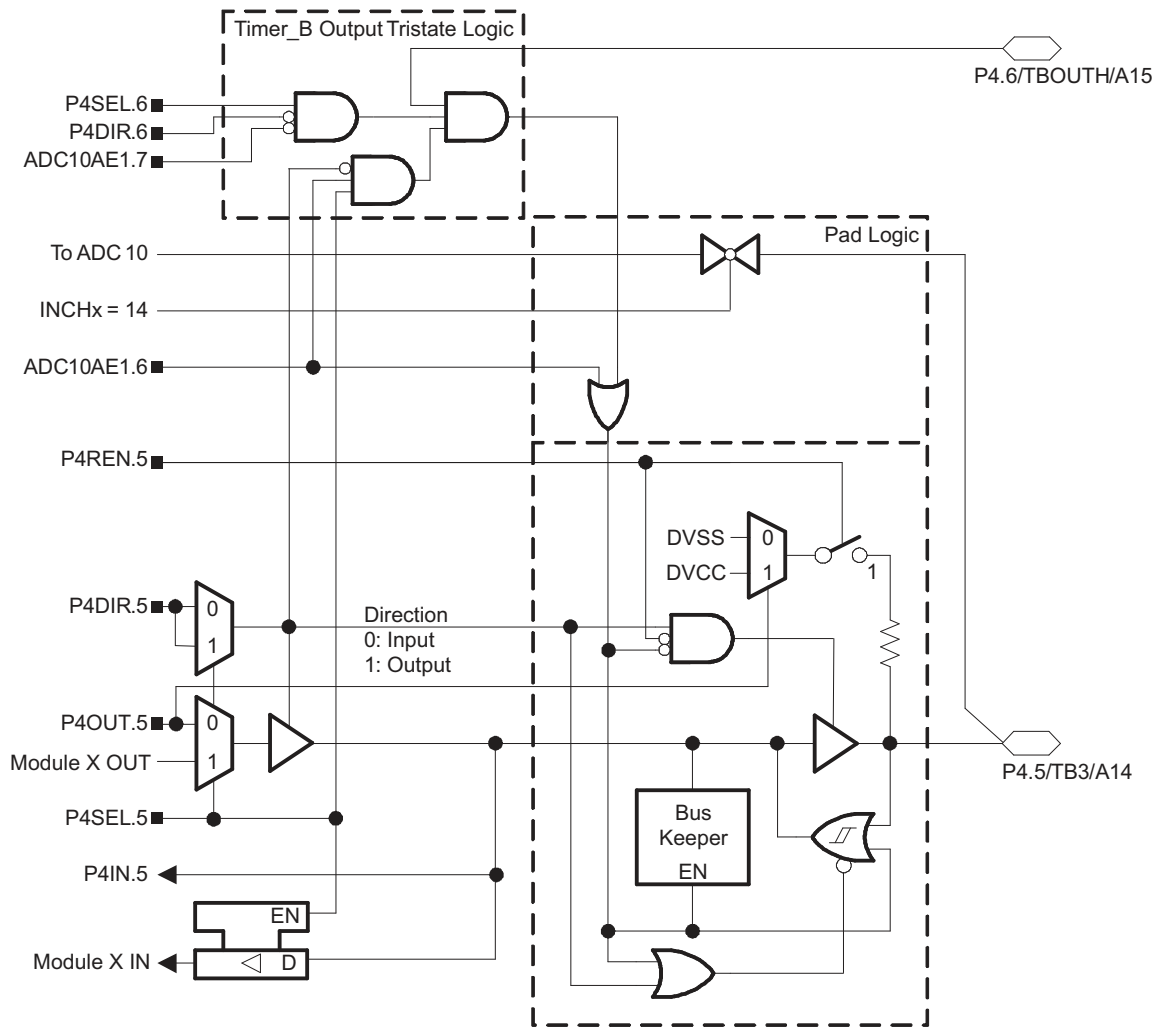

**Table 31. Port P4 (P4.5) Pin Functions**

PIN NAME (P4.x)	x	y	FUNCTION	CONTROL BITS/SIGNALS <sup>(1)</sup>		
				P4DIR.x	P4SEL.x	ADC10AE1.y
P4.5/TB3/A14	5	6	P4.5 <sup>(2)</sup> (I/O)	I: 0; O: 1	0	0
			Timer_B3.TB2	1	1	0
			A14 <sup>(3)</sup>	X	X	1

- (1) X = Don't care
- (2) Default after reset (PUC/POR)
- (3) Setting the ADC10AE1.y bit disables the output driver as well as the input Schmitt trigger to prevent parasitic cross currents when applying analog signals.

Port P4 Pin Schematic: P4.6, Input/Output With Schmitt Trigger

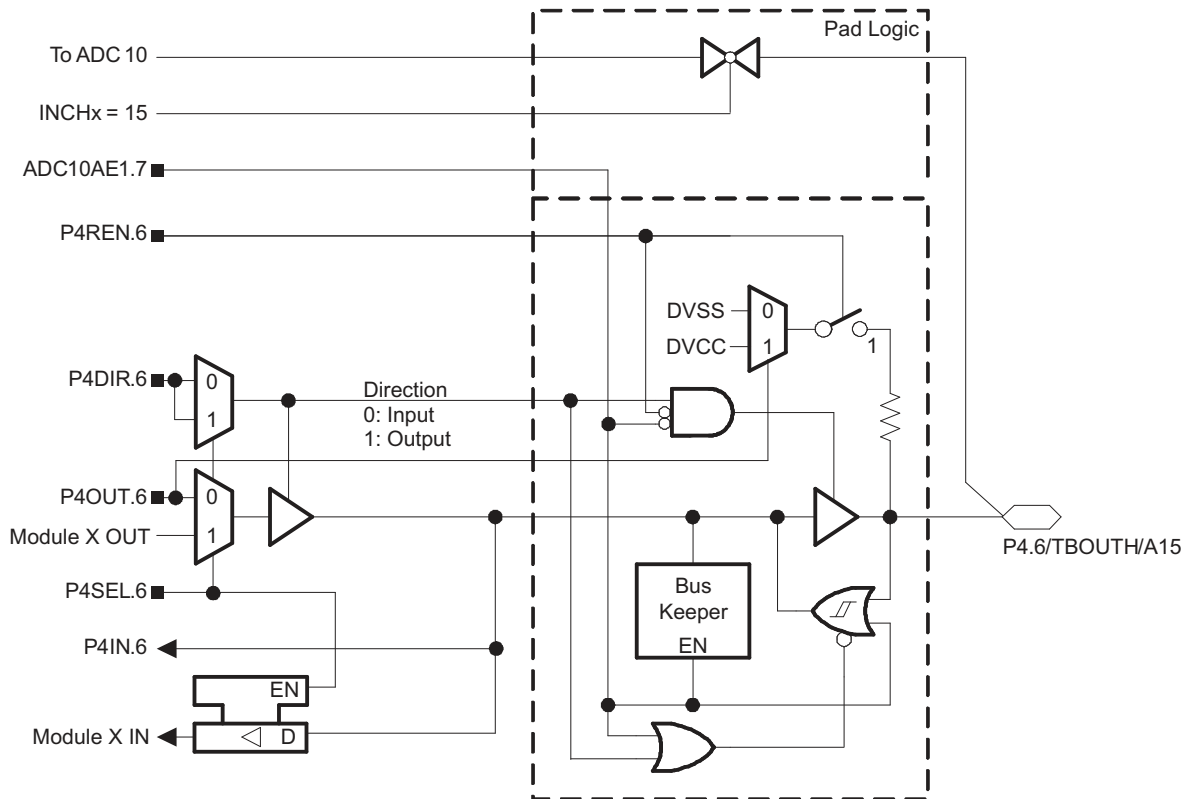
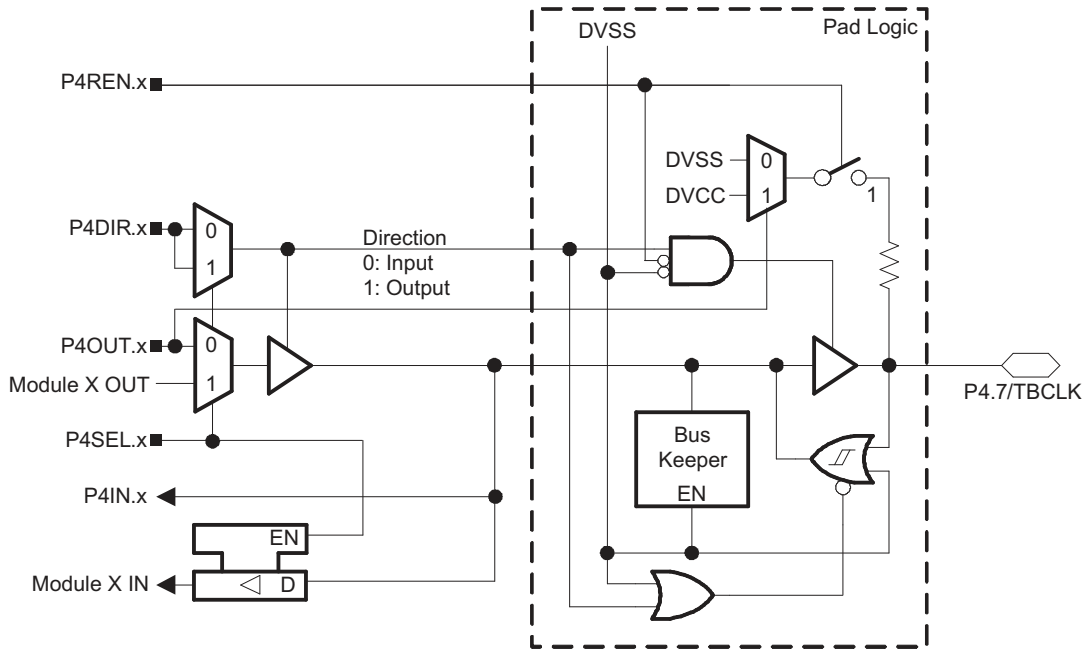

Table 32. Port P4 (P4.6) Pin Functions

PIN NAME (P4.x)	x	y	FUNCTION	CONTROL BITS/SIGNALS <sup>(1)</sup>		
				P4DIR.x	P4SEL.x	ADC10AE1.y
P4.6/TBOUTH/A15	6	7	P4.6 <sup>(2)</sup> (I/O)	I: 0; O: 1	0	0
			TBOUTH	0	1	0
			DV <sub>SS</sub>	1	1	0
			A15 <sup>(3)</sup>	X	X	1

- (1) X = Don't care
- (2) Default after reset (PUC/POR)
- (3) Setting the ADC10AE1.y bit disables the output driver as well as the input Schmitt trigger to prevent parasitic cross currents when applying analog signals.

**Port P4 Pin Schematic: P4.7, Input/Output With Schmitt Trigger**



**Table 33. Port P4 (Pr.7) Pin Functions**

PIN NAME (P4.x)	x	FUNCTION	CONTROL BITS/SIGNALS	
			P4DIR.x	P4SEL.x
P4.7/TBCLK	7	P4.7 <sup>(1)</sup> (I/O)	I: 0; O: 1	0
		Timer_B3.TBCLK	0	1
		DV <sub>SS</sub>	1	1

(1) Default after reset (PUC/POR)



## JTAG Fuse Check Mode

NN325-Q1 devices that have the fuse on the TEST terminal have a fuse check mode that tests the continuity of the fuse the first time the JTAG port is accessed after a power-on reset (POR). When activated, a fuse check current,  $I_{TF}$ , of 1 mA at 3 V, 2.5 mA at 5 V can flow from the TEST pin to ground if the fuse is not burned. Care must be taken to avoid accidentally activating the fuse check mode and increasing overall system power consumption.

When the TEST pin is again taken low after a test or programming session, the fuse check mode and sense currents are terminated.

Activation of the fuse check mode occurs with the first negative edge on the TMS pin after power up or if TMS is being held low during power up. The second positive edge on the TMS pin deactivates the fuse check mode. After deactivation, the fuse check mode remains inactive until another POR occurs. After each POR the fuse check mode has the potential to be activated.

The fuse check current flows only when the fuse check mode is active and the TMS pin is in a low state (see [Figure 25](#)). Therefore, the additional current flow can be prevented by holding the TMS pin high (default condition).

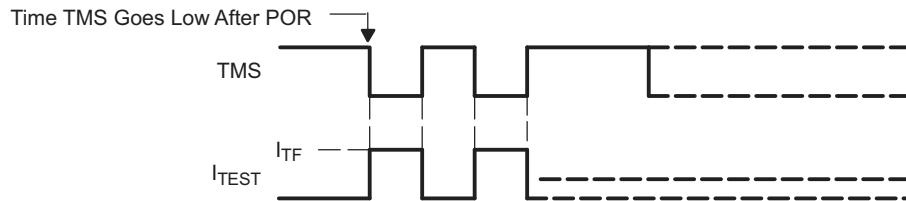

**Figure 25. Fuse Check Mode Current**

### NOTE

The CODE and RAM data protection is ensured if the JTAG fuse is blown and the 256-bit bootloader access key is used. Also, see the [Bootstrap Loader](#) section for more information.

**PACKAGING INFORMATION**

Orderable Device	Status (1)	Package Type	Package Drawing	Pins	Package Qty	Eco Plan (2)	Lead finish/ Ball material (6)	MSL Peak Temp (3)	Op Temp (°C)	Device Marking (4/5)	Samples
NN325TRHARQ1	ACTIVE	VQFN	RHA	40	2500	RoHS & Green	NIPDAU	Level-3-260C-168 HR	-40 to 105	NN325 TQ1	<b>Samples</b>

(1) The marketing status values are defined as follows:

**ACTIVE:** Product device recommended for new designs.

**LIFEBUY:** TI has announced that the device will be discontinued, and a lifetime-buy period is in effect.

**NRND:** Not recommended for new designs. Device is in production to support existing customers, but TI does not recommend using this part in a new design.

**PREVIEW:** Device has been announced but is not in production. Samples may or may not be available.

**OBSOLETE:** TI has discontinued the production of the device.

(2) **RoHS:** TI defines "RoHS" to mean semiconductor products that are compliant with the current EU RoHS requirements for all 10 RoHS substances, including the requirement that RoHS substance do not exceed 0.1% by weight in homogeneous materials. Where designed to be soldered at high temperatures, "RoHS" products are suitable for use in specified lead-free processes. TI may reference these types of products as "Pb-Free".

**RoHS Exempt:** TI defines "RoHS Exempt" to mean products that contain lead but are compliant with EU RoHS pursuant to a specific EU RoHS exemption.

**Green:** TI defines "Green" to mean the content of Chlorine (Cl) and Bromine (Br) based flame retardants meet JS709B low halogen requirements of <=100ppm threshold. Antimony trioxide based flame retardants must also meet the <=1000ppm threshold requirement.

(3) MSL, Peak Temp. - The Moisture Sensitivity Level rating according to the JEDEC industry standard classifications, and peak solder temperature.

(4) There may be additional marking, which relates to the logo, the lot trace code information, or the environmental category on the device.

(5) Multiple Device Markings will be inside parentheses. Only one Device Marking contained in parentheses and separated by a "~" will appear on a device. If a line is indented then it is a continuation of the previous line and the two combined represent the entire Device Marking for that device.

(6) Lead finish/Ball material - Orderable Devices may have multiple material finish options. Finish options are separated by a vertical ruled line. Lead finish/Ball material values may wrap to two lines if the finish value exceeds the maximum column width.

**Important Information and Disclaimer:**The information provided on this page represents TI's knowledge and belief as of the date that it is provided. TI bases its knowledge and belief on information provided by third parties, and makes no representation or warranty as to the accuracy of such information. Efforts are underway to better integrate information from third parties. TI has taken and continues to take reasonable steps to provide representative and accurate information but may not have conducted destructive testing or chemical analysis on incoming materials and chemicals. TI and TI suppliers consider certain information to be proprietary, and thus CAS numbers and other limited information may not be available for release.

In no event shall TI's liability arising out of such information exceed the total purchase price of the TI part(s) at issue in this document sold by TI to Customer on an annual basis.

**TAPE AND REEL INFORMATION**

**QUADRANT ASSIGNMENTS FOR PIN 1 ORIENTATION IN TAPE**

\*All dimensions are nominal

Device	Package Type	Package Drawing	Pins	SPQ	Reel Diameter (mm)	Reel Width W1 (mm)	A0 (mm)	B0 (mm)	K0 (mm)	P1 (mm)	W (mm)	Pin1 Quadrant
NN325TRHARQ1	VQFN	RHA	40	2500	330.0	16.4	6.3	6.3	1.1	12.0	16.0	Q2

**TAPE AND REEL BOX DIMENSIONS**

\*All dimensions are nominal

Device	Package Type	Package Drawing	Pins	SPQ	Length (mm)	Width (mm)	Height (mm)
NN325TRHARQ1	VQFN	RHA	40	2500	356.0	356.0	35.0

## GENERIC PACKAGE VIEW

**RHA 40**

**VQFN - 1 mm max height**

6 x 6, 0.5 mm pitch

PLASTIC QUAD FLATPACK - NO LEAD

This image is a representation of the package family, actual package may vary.  
Refer to the product data sheet for package details.

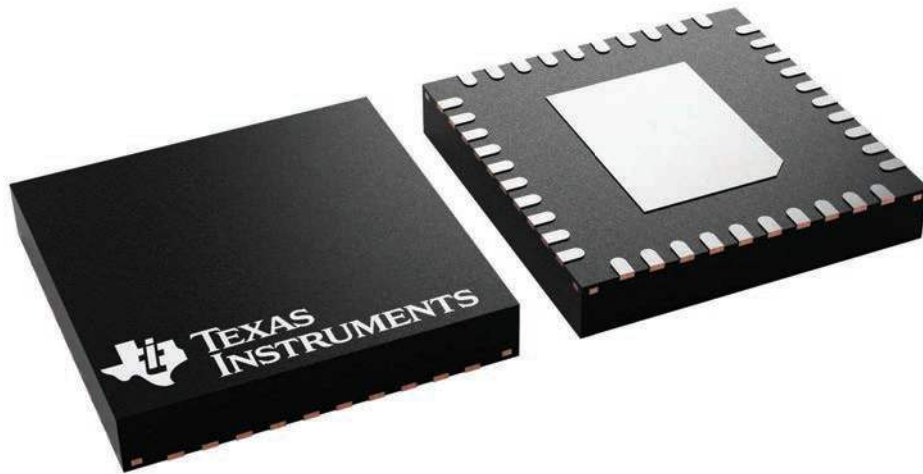

4225870/A

# RHA0040B



## PACKAGE OUTLINE

### VQFN - 1 mm max height

PLASTIC QUAD FLATPACK - NO LEAD

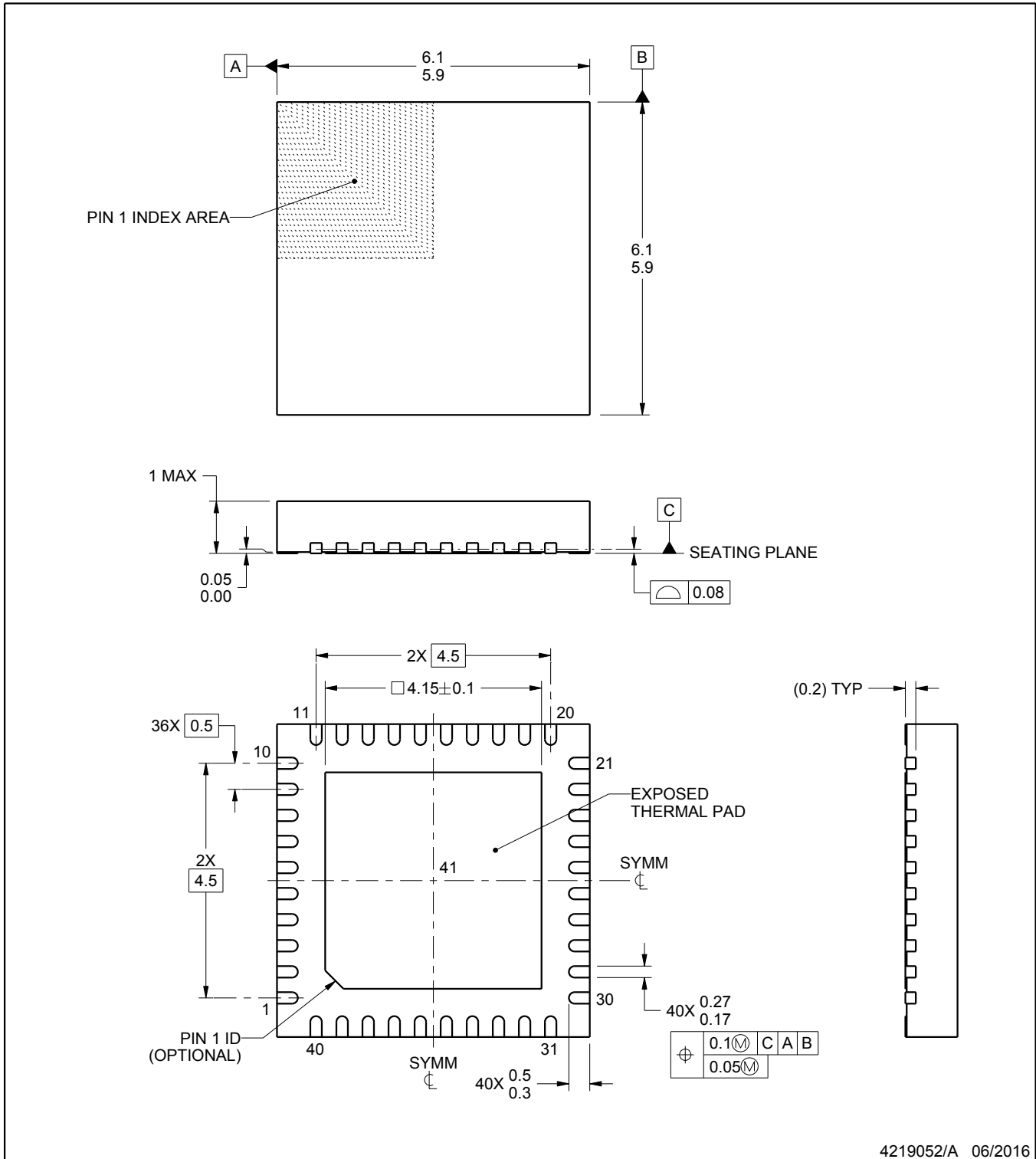

4219052/A 06/2016

#### NOTES:

1. All linear dimensions are in millimeters. Any dimensions in parenthesis are for reference only. Dimensioning and tolerancing per ASME Y14.5M.
2. This drawing is subject to change without notice.
3. The package thermal pad must be soldered to the printed circuit board for thermal and mechanical performance.

# EXAMPLE BOARD LAYOUT

RHA0040B

VQFN - 1 mm max height

PLASTIC QUAD FLATPACK - NO LEAD

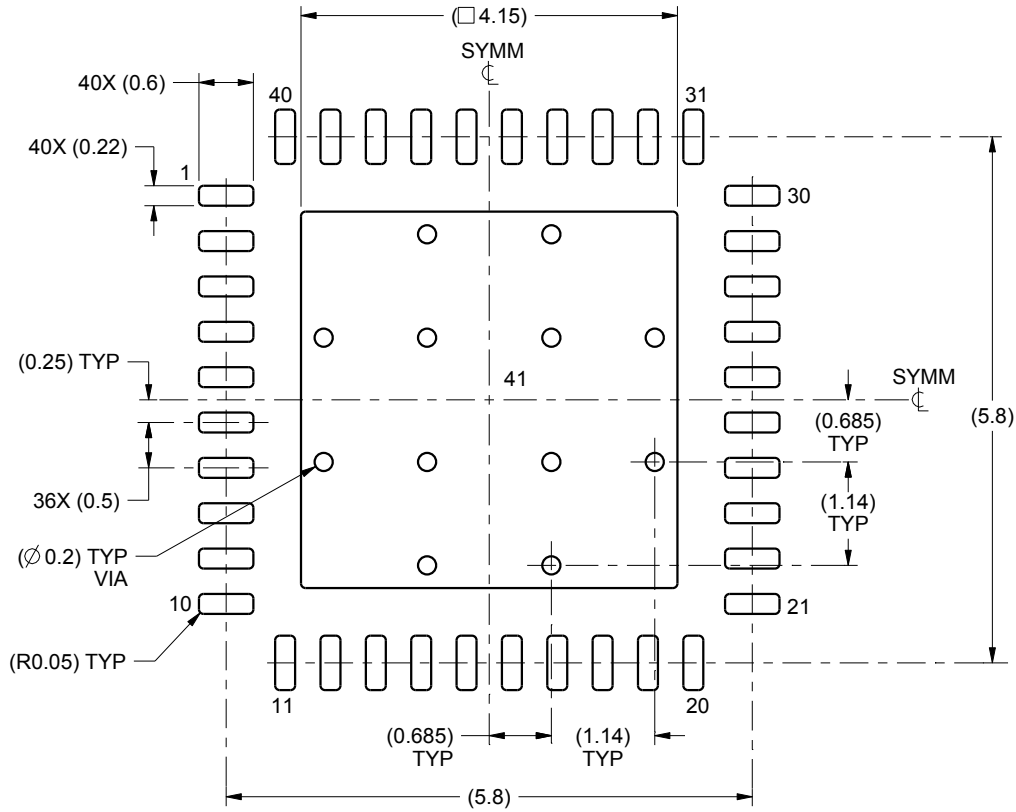

LAND PATTERN EXAMPLE  
SCALE:12X

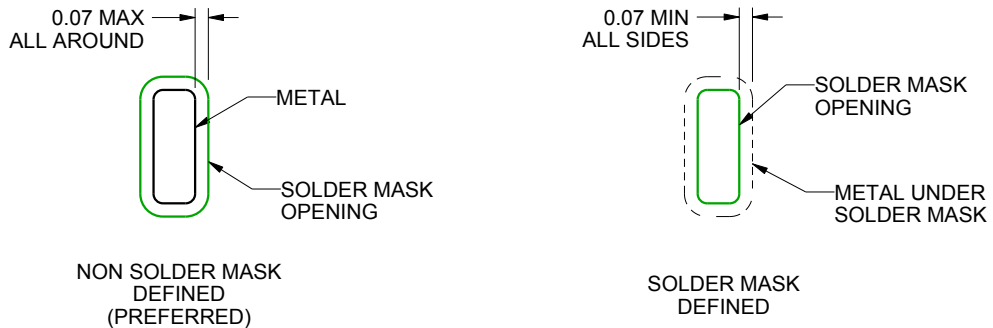

SOLDER MASK DETAILS

4219052/A 06/2016

NOTES: (continued)

4. This package is designed to be soldered to a thermal pad on the board. For more information, see Texas Instruments literature number SLUA271 ([www.ti.com/lit/slua271](http://www.ti.com/lit/slua271)).

# EXAMPLE STENCIL DESIGN

RHA0040B

VQFN - 1 mm max height

PLASTIC QUAD FLATPACK - NO LEAD

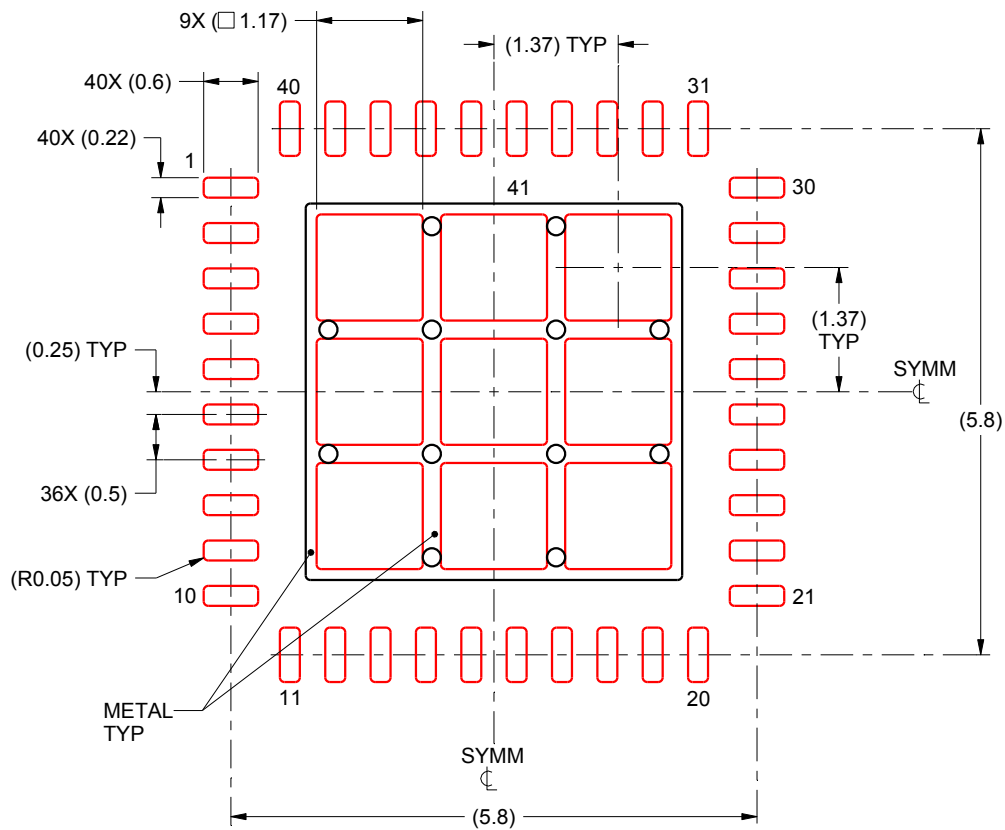

**SOLDER PASTE EXAMPLE**  
BASED ON 0.125 mm THICK STENCIL

EXPOSED PAD 41:  
72% PRINTED SOLDER COVERAGE BY AREA UNDER PACKAGE  
SCALE:12X

4219052/A 06/2016

NOTES: (continued)

5. Laser cutting apertures with trapezoidal walls and rounded corners may offer better paste release. IPC-7525 may have alternate design recommendations.



## IMPORTANT NOTICE AND DISCLAIMER

TI PROVIDES TECHNICAL AND RELIABILITY DATA (INCLUDING DATA SHEETS), DESIGN RESOURCES (INCLUDING REFERENCE DESIGNS), APPLICATION OR OTHER DESIGN ADVICE, WEB TOOLS, SAFETY INFORMATION, AND OTHER RESOURCES "AS IS" AND WITH ALL FAULTS, AND DISCLAIMS ALL WARRANTIES, EXPRESS AND IMPLIED, INCLUDING WITHOUT LIMITATION ANY IMPLIED WARRANTIES OF MERCHANTABILITY, FITNESS FOR A PARTICULAR PURPOSE OR NON-INFRINGEMENT OF THIRD PARTY INTELLECTUAL PROPERTY RIGHTS.

These resources are intended for skilled developers designing with TI products. You are solely responsible for (1) selecting the appropriate TI products for your application, (2) designing, validating and testing your application, and (3) ensuring your application meets applicable standards, and any other safety, security, regulatory or other requirements.

These resources are subject to change without notice. TI grants you permission to use these resources only for development of an application that uses the TI products described in the resource. Other reproduction and display of these resources is prohibited. No license is granted to any other TI intellectual property right or to any third party intellectual property right. TI disclaims responsibility for, and you will fully indemnify TI and its representatives against, any claims, damages, costs, losses, and liabilities arising out of your use of these resources.

TI's products are provided subject to [TI's Terms of Sale](#) or other applicable terms available either on [ti.com](http://ti.com) or provided in conjunction with such TI products. TI's provision of these resources does not expand or otherwise alter TI's applicable warranties or warranty disclaimers for TI products.

TI objects to and rejects any additional or different terms you may have proposed.

Mailing Address: Texas Instruments, Post Office Box 655303, Dallas, Texas 75265  
Copyright © 2022, Texas Instruments Incorporated