

HTADC12 (Die Deliverable) High Temperature 12-Bit, 100kSPS A/D Converter

The HTADC12 is a high temperature 12-bit, 100kSPS, analog-to-digital converter with on-chip buffered voltage reference and an on-chip analog input buffer. The HTADC12 uses a Successive Approximation Register (SAR) architecture that does not require an input sample-and-hold amplifier to provide 12-bit resolution at 100 kSPS data rates over the full operating temperature range of -55°C to +225°C.

The HTADC12 is fabricated on a high temperature Silicon On Insulator (SOI) CMOS process with very low power consumption.

The input of the HTADC12 allows for easy interfacing to sensors for data conversion applications. The direct input supports 0V to 2.5V signals and there is also an on-chip buffer to allow for full 5V input signals. The product is offered with both a serial and parallel digital output interface.

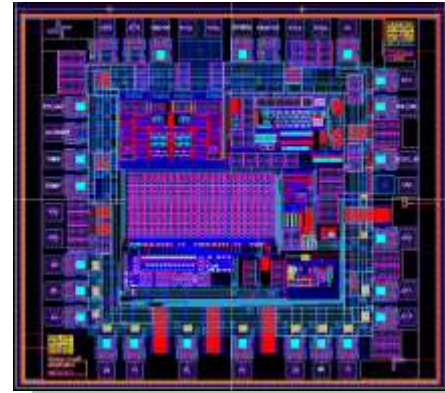

The switched capacitor charge-redistribution DAC architecture does not require a sample-and-hold input stage. It is well suited for both multiplexed systems that switch full-scale voltage levels in successive channels and also for sampling single-channel inputs at frequencies up to and well beyond the Nyquist rate. An internal clock is used to operate the HTADC12.

The digital output data is presented in straight binary output format. There are three output formats: 12 bit parallel, two 8 bit parallel, and serial.

FEATURES

- Monolithic 12-Bit, 100 kSPS A/D Converter
- Operating temperature range of -55°C to +225°C
- +5 V operation
- On-chip high temperature voltage reference
- Buffered voltage reference output pin
- On-chip analog input buffer
- Straight binary output data
- Typical INL of +/- 0.6 LSB at 225°C
- Parallel 12-bit output or serial output
- Input flexibility to use internal reference or off-chip reference.

Die Deliverable

The HTADC12 die can be incorporated in multi-chip packages.

Low Power

The HTADC12, at 10 mW, consumes a fraction of the power of presently available ADCs in existing monolithic solutions.

HTADC12

DIE BLOCK AND PIN DIAGRAMS

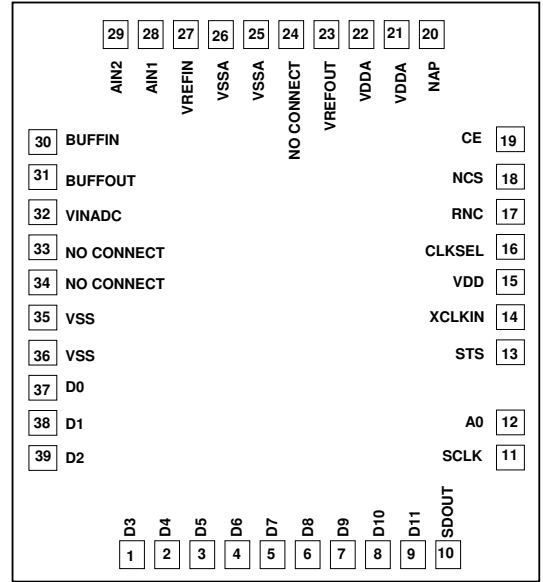
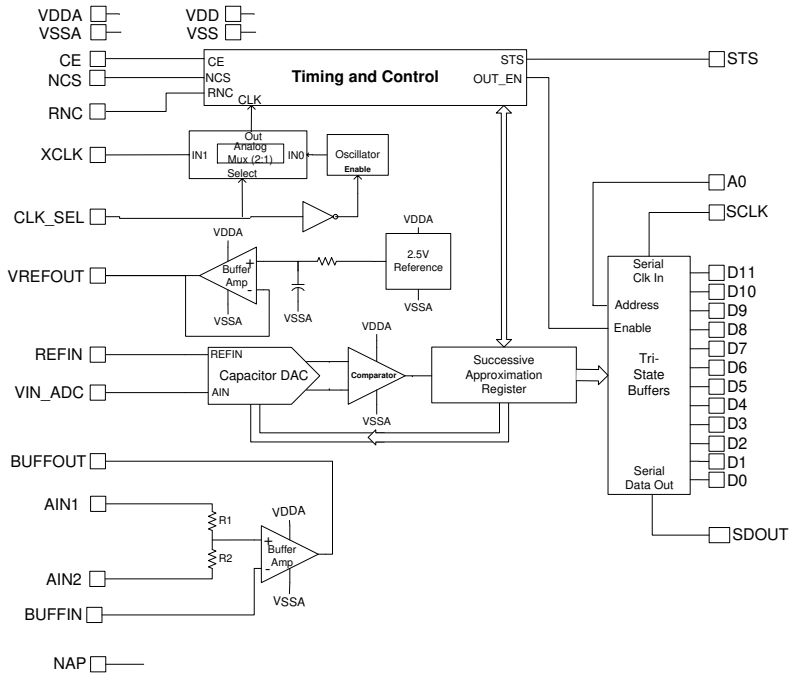

PIN DESCRIPTION

Pad	Pad Name	Description
1	D3	Data Output (Note 1)
2	D4	Data Output (Note 1)
3	D5	Data Output (Note 1)
4	D6	Data Output (Note 1)
5	D7	Data Output (Note 1)
6	D8	Data Output (Note 1)
7	D9	Data Output (Note 1)
8	D10	Data Output (Note 1)
9	D11	Data Output (Note 1)
10	SDOUT	Serial Data Output - Digital data output. (Note 1)
11	SCLK	Serial Clock Input - This signal is used to clock out the serial digital data.
12	A0	Output Data Byte Select Input - The digital data can be output as a standard 12 bit parallel output or can be presented in two 8-bit bytes for use with 8 bit microprocessors. The 8 bit bus will be aligned with D4 – D11. <u>When A0 is low</u> , the digital data is output in a standard 12 bit format (D0 = LSB). This will also represent the first byte (bits D4 – D11) for an 8 bit system. <u>When A0 is high</u> , the second byte will be available at the output. D11 through D8 now contain the 4 LSB's of the 12-bit parallel data (D0 – D3). The remaining bits are unused. D7-D4 are all zeroes. D3 - D0 retain their A0=0 values.
13	STS	Data Conversion Status Output - Status = 1, Conversion in progress.
14	XCLKIN	External clock input (Digital input). Function not supported. Wirebond to VSS.
15	VDD	5V Digital Supply (Note 2)
16	CLKSEL	Clock Select (Digital input). CLKSEL = 0, internal clock is selected. Wirebond to VSS.
17	RNC	Read/Not Convert Input - A high-to-low transition initiates an A-to-D conversion. When held low, the outputs are in a high impedance mode.
18	NCS	Not Chip Select Input – A low input will select the chip and enable the outputs. A high input will de-select the chip and place the outputs in a high impedance state.

HTADC12

Pad	Pad Name	Description
19	CE	Chip Enable Input - A high input will enable the chip and enable the outputs. A low input will disable the chip and place the outputs in a high impedance state.
20	NAP	Power down control (digital input). NAP=0 for normal operation.
21	VDDA	5V Analog Supply (Note 2)
22	VDDA	5V Analog Supply (Note 2)
23	VREFOUT	VREF Buffered Output. Nominally 2.5V buffered output of on-chip voltage reference. May be connected to VREFIN on the board.
24	NO CONNECT	Leave pad open
25	VSSA	Analog Ground (Note 2)
26	VSSA	Analog Ground (Note 2)
27	VREFIN	Voltage Reference Input. May be connected to VREFOUT or to an external voltage reference.
28	AIN1	Analog Input - Input to buffer amplifier
29	AIN2	Analog Input - Input to buffer amplifier
30	BUFFIN	Analog Input - Input to negative terminal of the buffer amplifier
31	BUFFOUT	Analog Output - Output of the buffer amplifier
32	VINADC	Analog Voltage Into A/D Converter
33	NO CONNECT	Leave pad open
34	NO CONNECT	Leave pad open
35	VSS	Digital Ground (Note 2)
36	VSS	Digital Ground (Note 2)
37	D0	Data Output. (Note 1)
38	D1	Data Output. (Note 1)
39	D2	Data Output. (Note 1)

Notes

- (1) The data outputs are tri-state drivers and may be put into a high impedance state according to truth table.
- (2) Where wirebond pads have the same labeling they are electrically connected on-chip (VDD, VDDA, VSS, and VSSA). VDDA and VDD should be connected externally to the same potential. VSSA and VSS should also be connected externally to the same potential. VDDA and VDD are separated on-chip to reduce inductive supply noise coupling to the analog front-end (from on-chip logic switching and/or output transients). VSSA and VSS are separated on-chip for the same reason.

TRUTH TABLE

CE	NCS	RNC	A0	Operation	Outputs
0	x	x	x	None	High Impedance
x	1	x	x	None	High Impedance
↑	0	0	x	Initiate conversion	High Impedance
1	↓	0	x	Initiate conversion	High Impedance
1	0	↓	x	Initiate conversion	High Impedance
1	0	1	x	Enable serial output	Enabled
1	0	1	0	Enable 12-bit parallel output (8 MSBs are read here when using 8-bit bus option)	Enabled
1	0	1	1	Enable 4 LSBs + 4 trailing zeroes, all super-imposed on 8 MSB outputs (8-bit bus option)	Enabled

HTADC12

ABSOLUTE MAXIMUM RATINGS (1)

Name	Parameter	Rating		Units
		Min	Max	
VDD	Supply Voltage (2)	-0.1	6.0	Volts
VPIN	Voltage on Any Pin (2)	-0.1	VDD+0.1	Volts
TSTORE	Storage Temperature	-55	300	°C
IOUT	Average Output Current		50	mA
ESD	Electrostatic Discharge Protection Voltage (3)		750	V
PJB	Die Thermal Resistance (Top Side Junction to Backside of Die)		0.54	°C/W

- (1) Stresses in excess of those listed above may result in immediate permanent damage to the device. These are stress ratings only, and operation at these levels is not implied. Frequent or extended exposure to absolute maximum conditions may affect device reliability.
- (2) Voltage referenced to VSS = 0V.
- (3) Class 1 Electrostatic Discharge (ESD) input protection voltage per MIL-STD-883, Method 3015

RECOMMENDED OPERATING CONDITIONS (1)

Symbol	Parameter	Description			
		Min	Typ	Max	
VDD	Supply Voltage	4.75	5.0	5.25	Volts
Temp Op	Operating Temperature	-55		225	°C
VPIN	Voltage on Any Pin	0.0		VDD	Volts
VREFIN	Input Voltage Reference	0.0		2.5	Volts

- (1) Voltages referenced to Vss = 0V.

DC ELECTRICAL CHARACTERISTICS (2)

Symbol	Parameter	Conditions(1)	Limits			Units
			Min	Typ	Max	
IDDA	VDD Quiescent Current	No external load on VREFOUT		2.5	5	mA
IDD	VDD Quiescent Current			150	250	µA
IDDA NAP	Quiescent Current VDDA	NAP=1 (on), No external load on VREFOUT.		500	1000	µA
IDD NAP	Quiescent Current VDD			150	250	µA
IOZ	Output Tri-State Leakage	Output High Impedance	-5		+5	µA
VIL	Low Level Input Voltage	Digital I/O signals			20	% of VDD (V)
VIH	High Level Input Voltage	Digital I/O signals	80			% of VDD (V)
VOH	High Level Output Voltage	Sourcing 4mA Current	VDD- 0.5			V
VOL	Low Level Output Voltage	Sinking 4mA Current			VSS+ 0.5	V
IIL	Input current at VIN=VSS	Digital I/O signals	-1		+1	µA
IIH	Input current at VIN=VDD	Digital I/O signals	-1		+1	µA

- (1) Unless otherwise specified, specifications apply over the full operating temperature range from -55°C to 225°C, VDDA externally connected to VDD = 5V, VSSA externally connected to VSS = 0V.
- (2) Electrical testing of wafers/die is conducted at 25°C only.

HTADC12

ELECTRICAL PERFORMANCE CHARACTERISTICS (6)

Symbol	Parameter	Conditions(1)	Limits			Units
			Min	Typ	Max	
# of Bits	Resolution (2)			12		Bits
INL	Integral Non-Linearity		-2.8		+2.8	LSB
DNL	Differential Non-Linearity		-1.0		+1.8	LSB
Offset	Offset Error	VIN value @ VOUT = Voltage equivalent to 0.0LSB (from Linear regression), T=25°C	-5	0	+5	LSB
OS_TC	Offset Error Tempco (7)		-5		+5	ppm/°C
FS_ERR	Full Scale Error	Maximum change in full scale calibration VREFIN = 2.5V, T=25°C	-0.3		+0.3	% of FS
FS_TC	FS Error Tempco (7)		-3		+3	ppm/°C
PSRA	Power Supply Rejection	Magnitude of Output Code	-1		1	LSB
PSRD	Power Supply Rejection		-1		1	LSB
VREFOUT	Reference Output Voltage		2.49		2.51	V
Δ VRO-TIME	VREFOUT Drift with time	T=225°C, Δt=1000 hours (2)	-3		+3	mV
ΔVRO /ΔVDDA	VREFOUT Line Regulation - DC		-1		+1	mV/V
ΔVRO /ΔIO	VREFOUT Load Regulation – DC (4)	0.0 mA ≤ Iout ≤ +8.0 mA			0.5	mV/mA
VRN	VREFOUT Noise (2)	f = 0.1Hz to 10kHz		110		μV rms
FSCLK	Serial Clock Frequency	Cload = 10pF, Note 3			40	MHz
TWAKEUP	Wake-up time from NAP (ADC ready to convert) (5)			30		μs
VOSAA	Auxiliary Amplifier Input Offset Voltage		-3	±1	+3	mV
BWAA	Auxiliary Amp Unity Gain Bandwidth (5)	Cload = 40pf	3	5		MHz
Δ R/R	Aux Amp Input Resistor Divider (/2)Matching (5)		-0.1		+0.1	%

Notes

- (1) Unless otherwise specified, specifications apply over the full operating temperature range from -55°C to 225°C, VDDA externally connected to VDD =5V, VSSA externally connected to VSS = 0V.
- (2) Guaranteed by initial qualification test.
- (3) Maximum serial clock frequency listed is for a 10pF load on SDOOUT. For greater capacitive loads, a lower clock frequency must be used. For Cload = 100pF, Fsclk = 10 MHz is the recommended maximum.
- (4) VREF_OUT can provide source current only.
- (5) Guaranteed by design.
- (6) Electrical testing of wafers/die is conducted at 25°C only.
- (7) Not tested at wafer or die level. Guaranteed by lot sample test of packaged parts.

HTADC12

SIGNAL DEFINITION

ANALOG INPUT OPTIONS

The analog input signal may be connected directly to the VIN ADC input or go through a buffer amplifier.

Direct into VINADC

The input range can be from 0V to VREFIN. This input is high impedance but should be driven by a low impedance source.

Input Utilizing Buffer Amp

The HTADC12 has an integrated buffer amplifier which can be used to condition the input signal. The access to the amplifier input and output pins provides the ability to create various conditioning circuits.

Both input terminals and the output terminal of the amplifier are available. On the positive terminal, the AIN1 and AIN2 inputs are configured to allow the signal to be divided by 2 through a resistor divider (with either AIN1 or AIN2 connected to VSSA = 0V). This provides the ability to use signals from 0V to 5V. The negative input terminal and output are on separate pins allowing additional circuits to be implemented. The maximum output value shall be VREFIN. The internal resistor values are 20k ohms.

This output may then be connected to VIN ADC which has an input range of 0V to VREFIN (or 2.5V maximum). The output buffer may also be used as a unity-gain input buffer by applying the analog input to both AIN1 and AIN2.

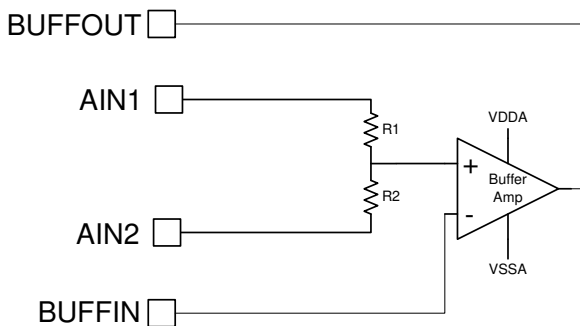

TRI-STATE OUTPUT CONTROL

The digital outputs are tri-state drivers. They are controlled by the CE, NCS, and RNC. To have the outputs active, CE and RNC must be high and NCS must be low.

RNC

The RNC signal is used to trigger an A-to-D Conversion by a high-to-low transition.

STS

This signal is a status indicator for the validity of the output data. STS is high while a conversion is in progress.

NAP

The NAP input may be used to put all analog circuitry except VREF into a low-current mode, saving power during inactive periods.

FUNCTIONAL DESCRIPTION

The A-to-D converter block consists of a 12-bit successive approximation analog-to-digital converter using an internal 12-bit capacitive charge re-distribution DAC. Conversions are initiated by a high-to-low transition on the RNC input. The analog input voltage range is from 0V to VREF_IN. While the conversion is in progress, the Status output (STS) is high and the parallel data outputs (D0 through D11) are in a high impedance state. When the conversion is complete, the data is made available on the parallel data output pins (D0 through D11). STS goes low indicating that data is ready. A complete A/D conversion cycle requires 38 clock cycles. The nominal internal clock frequency is 4 MHz.

ADC Clocking: The internal A/D clock is nominally 4 MHz, and is approximately temperature and supply independent. At the nominal clock frequency the ADC throughput is approximately 100KSamples/sec. Use of an external clock on XCLKIN (Pin 14) is not supported.

Voltage Reference Options: The full-scale input range of the ADC is 0V to VREFIN. The 12-bit ADC has an internal, buffered reference source VREFOUT. VREFOUT is within 2.49V to 2.51V over all conditions (-55°C to +225°C). The reference buffer is designed to provide a low-impedance output capable of settling within the sampling time of the ADC when operated with the 4MHz clock.

To use this reference connect VREFOUT directly to VREFIN. Do not add decoupling capacitors at this connection. The capacitance on VREFOUT should be minimized. An external voltage reference may be used instead of the internal reference source. In that case, the external source may be connected directly to VREFIN and VREFOUT may be left un-connected.

ADC Converter Control:

Four signals are used to control the ADC.

- Conversion Control: CE, NCS, and RNC
- Output Buffer Control: CE, NCS, and RNC
- Output Format: A0

Conversion Control

HTADC12

It is recommended to use RNC as the signal to trigger the conversion and read functions. CE and NCS should be used as enables. Refer to timing diagrams.

However, the CE, NCS, and RNC have equivalent signal functions. A conversion can be initiated by a

transition on the any of the control lines, as shown in the Truth Table.

Once a conversion is started, it can be terminated and restarted by reasserting the appropriate control lines.

RECOMMENDED OPERATING MODES

There are two main methods of operating the HTADC12, Open Loop and Closed Loop.

Open Loop

The HTADC12 can be used in an open loop mode in which the enable pins are held at a steady value and conversions are triggered by RNC. The output data is available and read when STS goes low. To trigger another conversion, only RNC has to be driven low.

(1) CE is held high and NCS is held low.

- (2) RNC is pulsed from a high to a low value which starts the conversion. RNC returns high before the conversion is completed.
- (3) The STS signal will then go to a high value.
- (4) When the conversion is complete, STS will go low indicating the data is available on the output bus.
- (5) The next conversion is started with another pulse on the RNC line.

OPEN LOOP TIMING DIAGRAM

Symbol	Parameter	Min	Typ	Max	Units
T1	STS Delay From RNC			100	ns
T2	Low RNC Pulse Width	20			ns
T3	Conversion Time (1)	9	10	11.5	μs
T4	STS Delay After Data Buffer Turn-On	50	80	110	ns
T5	Data Valid Hold Time after RNC low	20			ns

Notes

- (1) Conversion Time based on 38 cycles of the internal 4MHz clock.

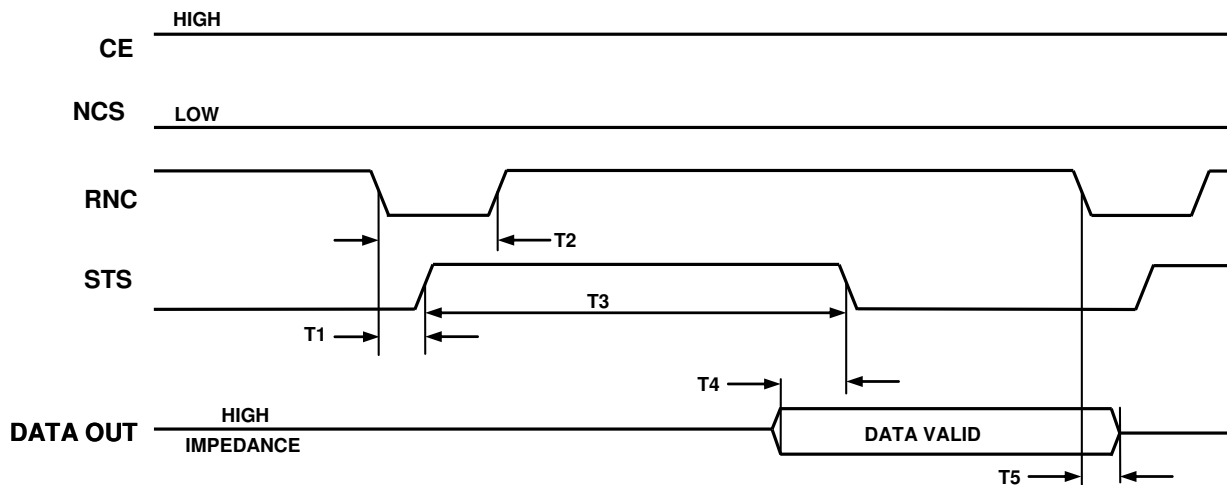

HTADC12

Closed Loop – Processor Controlled

This mode requires control of the input enable pins CE, NCS, and RNC. The STS signal will be used to notify the processor that a conversion is complete. The processor then changes the state of RNC to read the output data.

Assuming that CE is high and NCS is low, a typical conversion sequence may be:

- (1) CE and NCS are set to activate the device.
- (2) RNC is then changed from a high to a low value which starts the conversion.

- (3) The STS signal will then go to a high value.
- (4) When the conversion is complete, STS will go low. This will be detected by the processor/controller.
- (5) The controller then sets RNC back to a high level and signaling the data can be read at the outputs.
- (6) Following the read, CE and NCS are then set to disable the device and put the outputs into a high impedance state.

CLOSED LOOP TIMING DIAGRAM

Symbol	Parameter	Min	Typ	Max	Units
T7	Setup Time NCS To RNC	0	5		ns
T6	Setup Time CE To RNC	0	5		ns
T1	STS Delay From RNC			100	ns
T3	Conversion Time	9	10	11.5	μs
T8	READ Delay After Enable			100	ns
T5	Data Valid Hold Time	20			ns

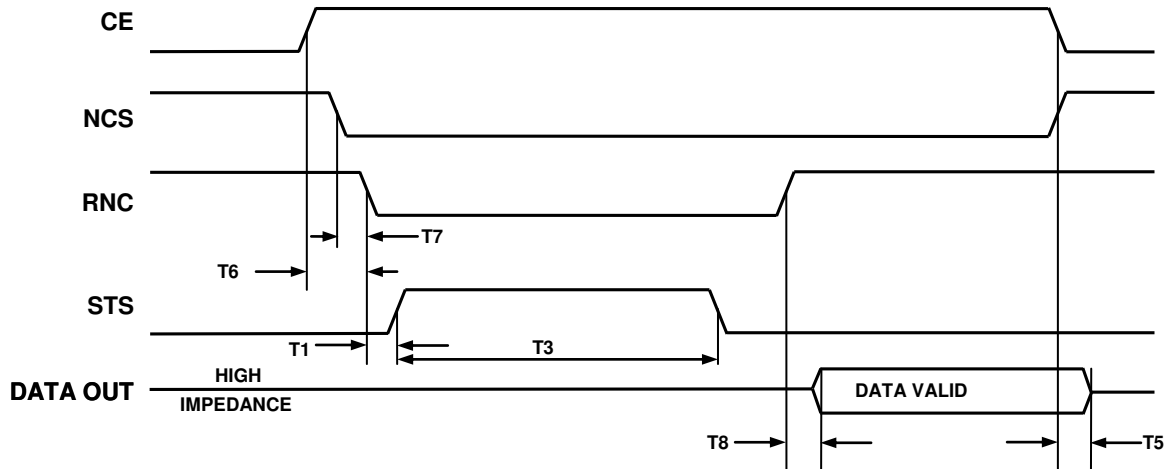

HTADC12

Data Output Formats: There are three output formats: 12 bit parallel, two 8 bit parallel, and serial.

Serial Output Control: Conversions in the serial output mode are initiated identically to the parallel output mode described above. The serial data output, SDO, is enabled identically as well.

Valid data becomes available at SDO immediately at the end of the conversion cycle (slightly prior to STS). Data is output MSB first, and advances one bit position with each SCLK falling edge.

Rising SCLK edges may be used to clock serial data into the master.

SCLK activity occurring other than when SDO is properly enabled for read is ignored.

The parallel data can be presented as either 12 straight binary bits or configured for a “two-byte READ” for use with 8 bit processor busses.

12-Bit Data Readout in 8-Bit Systems: The HTADC12’s 12-bit parallel data output can be read out by an 8-bit system in two 8-bit bytes. In this mode, the

8 MSB bit positions of the 12-bit output are utilized as the 8-bit bus. Address control of the byte of interest is handled by the logic state of the A0 control line.

- When A0=0, the output data assumes its normal 12-bit format with bits D11-D4 of the 12-bit word forming the 1st data byte.
- When A0=1, bits D3-D0 followed by 4 logic zeroes are superimposed onto the 8 MSB bit positions, forming the 2nd data byte.

Data Output Pins	Data Output Values	
	A0 = 0 (READ bits D4 – D11)	A0 = 1 (READ bits D0 – D3)
D11	D11	D3
D10	D10	D2
D9	D9	D1
D8	D8	D0
D7	D7	“0”
D6	D6	“0”
D5	D5	“0”
D4	D4	“0”
D3	D3	D3
D2	D2	D2
D1	D1	D1
D0	D0	D0

SERIAL OUTPUT TIMING DIAGRAM

Symbol	Parameter	Min	Typ	Max	Units
T4	STS Delay After Data Buffer Turn-On	50	80	110	ns
T9	Rising Edge of First Clock	0			ns

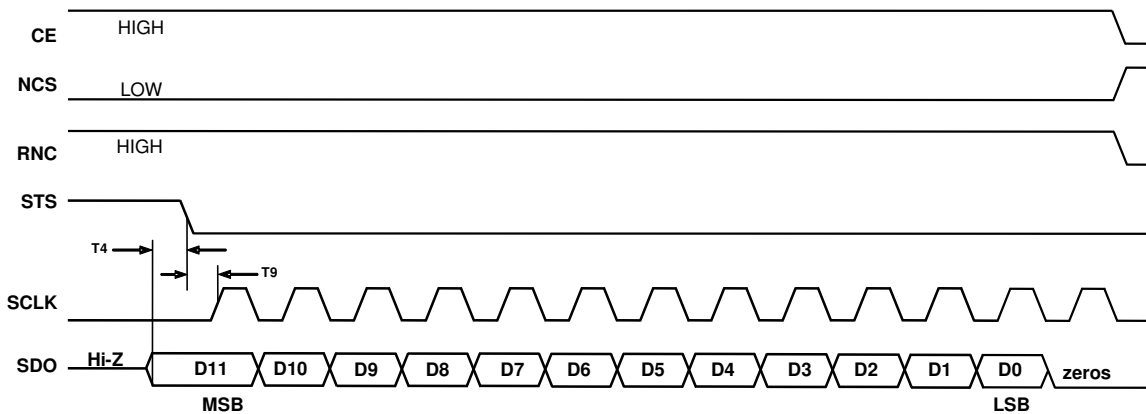

HTADC12

SWITCHING TIME

Delay time to achieve settled data when switching between the two data bytes will be dependent on the amount of load capacitance present on the output drivers. A general guideline for estimating the delay is given by the formula

$$TD = 4.0 \text{ ns} + 0.25 \text{ ns/pF} \times C_L$$

where TD is the delay time in ns, and C_L is the capacitive load on each output driver in pF.

TD represents the total time required for an output driver's voltage level to fall to 10% of its previous logic high value, or to rise to 90% of its logic high value from a logic low, after A0 is asserted.

Load (pF)	Approximate TD (ns)
10	6.5
50	32.5
100	65.0

GROUNDING AND DECOUPLING

Analog and Digital Grounding

Proper grounding is essential in any high speed, high-resolution system. Multilayer printed circuit boards (PCBs) are recommended to provide optimal grounding and power schemes. The use of ground and power planes offers distinct advantages:

1. The minimization of the loop area encompassed by a signal and its return path.
2. The minimization of the impedance associated with ground and power paths.
3. The inherent distributed capacitor formed by the power plane, PCB insulation and ground plane.

These characteristics result in both a reduction of electromagnetic interference (EMI) and an overall improvement in performance.

It is important to design a layout that prevents noise from coupling onto the input signal. Digital signals should not be run in parallel with analog input signal traces and should be routed away from the input circuitry. While the HTADC12 features separate analog and digital power and ground pins, it should be treated as an analog component. The VSSA and VSS pins must be joined together directly under the HTADC12. A solid ground plane under the A/D is acceptable if the power and ground return currents are carefully managed. Alternatively, the ground plane under the A/D may contain serrations to steer currents in predictable directions where cross coupling between analog and digital would otherwise be unavoidable.

Analog and Digital Driver Supply Decoupling

The HTADC12 features separate analog and digital supply and ground pins, helping to minimize digital corruption of sensitive analog signals.

In general, VDDA, the analog supply, should be decoupled to VSSA, the analog common, as close to the chip as physically possible.

RELIABILITY

Honeywell understands the stringent reliability requirements that high temperature systems require and has extensive experience in reliability testing on programs of this nature. Reliability attributes of the SOI CMOS process were characterized by testing specially designed structures to evaluate failure mechanisms including hot carriers, electro-migration, and time-dependent dielectric breakdown. The results are fed back to improve the process to ensure the highest reliability products.

HTADC12

DIE OUTLINE DIMENSIONS

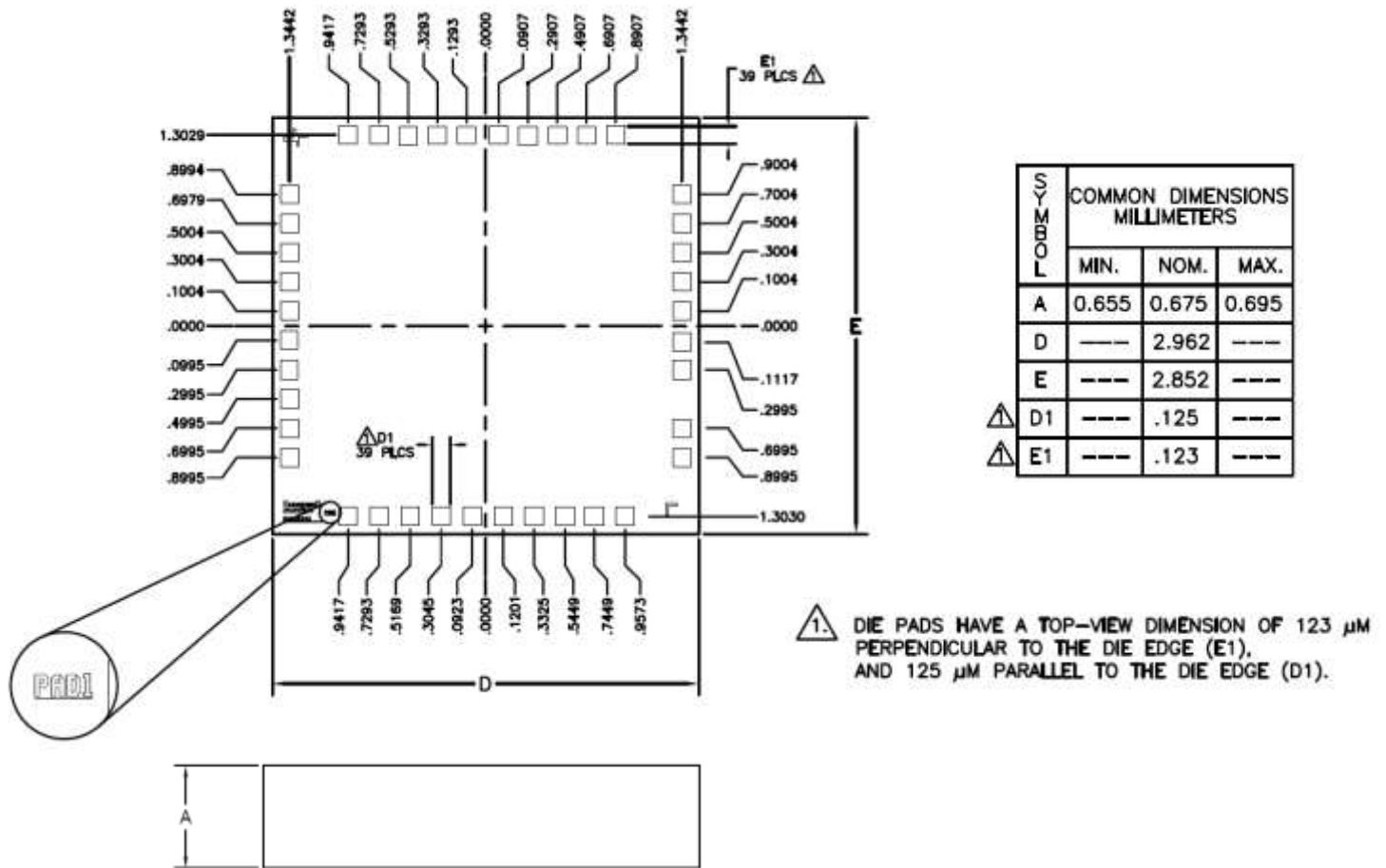

Notes:

- (1) Backside metalization is gold.
- (2) Metalization on the pads is aluminum.
- (3) The backside of the die is connected to VSS.

ASSEMBLY INFORMATION

Die Bonding

Honeywell recommends using a Eutectic Gold/Silicon perform or high temperature conductive adhesive for die bonding to a ceramic package.

Wirebonding

Aluminum bond wires must be used to achieve high temperature reliability. Wirebond the power and ground pads before the other signal pads.

DIE LEVEL SCREENING

The HTADC12 die are specified to operate over the entire temperature range. To meet this objective, three levels of screening are in place.

1. Wafer Level – Each die is 100% electrical tested at room temperature.
2. Sample Package Test – A sample of die from each wafer are assembled into packages and screened over the temperature range of -55C to +225C to verify performance.
3. The sample packaged parts also receive 44 hours of burn-in at 250C.

HTADC12

ORDERING INFORMATION

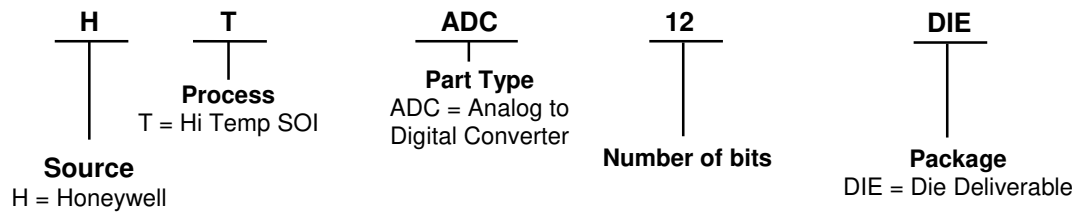

FIND OUT MORE

For more information on Honeywell's High Temperature Electronics visit us online at www.hightempsolutions.com, or contact us at 800-323-8295 or 763-954-2474. Customer Service Email: ssec.customer.service@honeywell.com.

Honeywell reserves the right to make changes of any sort without notice to any and all products, technology and testing identified herein. You are advised to consult Honeywell or an authorized sales representative to verify that the information in this data sheet is current before ordering this product. Absent express contract terms to the contrary, Honeywell does not assume any liability of any sort arising out of the application or use of any product or circuit described herein; nor does it convey any license or other intellectual property rights of Honeywell or of third parties.