

General

Ver 1.31

IoT-S300E is one of world's smallest model, of which persistent Stability and Temperature effect resistance besides various outputs, is much favored by customers whose application needs utmost big number of monitoring HVAC points.

ELT Sensor Data Sheet for IoT-S300E

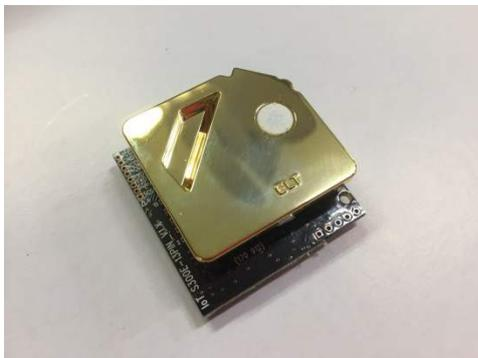

Features

- Gold-plated sensor provides long-term calibration stability.
- Pre-calibrated
- Available outputs : TTL-UART (Option: I2C)
- Installed re-calibration function
- Operate itself with ACDL mode (Automatic Calibration in Dimming Light mode) as default.
- MCDL mode (Manual Calibration in Dimming Light mode) is executable as customer needs.
- Size : 33mmx33mmx13.1mm
- Weight : 10 grams

IoT-S300E Specifications

General Performance

Operating Temperature : -10 ~ 50 °C
Operating Humidity : 0 ~ 95% RH (Non-condensing)
Operating Environment : Residential, Commercial spaces
Storage Temperature : -30 °C ~70 °C

CO₂ Measurement

Sensing Method : NDIR (Non-dispersive Infrared)
Measurement Range : 400 ~ 5,000ppm
Accuracy : ±50ppm ± 5% of reading with ACDL Logic condition. ⁽¹⁾⁽²⁾
Step Response Time (1/e) : 60 seconds
Sampling Interval: 5 seconds
Warming-up Time : < 6seconds (for Detection), 5 minutes (for Accuracy)

Electrical Data

Power Input : 5.0V (4.75~5.25V) ⁽³⁾
Power Consumption : Normal : 5.6mA, Max : 300mA at lamp on peak

Product Derivatives and Relative Functions

Products	Feature
IoT-S300E	UART, I2C, 10' MCDL, ACDL, 4+10 & 8 Connector
IoT-S300EA (S/W ACDL)	Calibration function is operated automatically every 7 days since power on unless 10' MCDL is on

(1) IAQ application, accuracy is defined after minimum 3 times calibration for 3 weeks.

(2) +/- 2% is added for absolute measurements for uncertainty of calibration gas mixture unless the measurement is done with certified calibration

(3) DC Supply should be regulated , low noise power source for best accuracy.,

Pin Map with J1(4PIN) & J2(10PIN) Connectors of IoT-S300E

TTL Level Voltage : $0 \leq V_{IL} \leq 0.8$, $1.8 \leq V_{IH} \leq V_{DD}$ (Volt), $0 \leq V_{OL} \leq 0.4$, $2.4 \leq V_{OH} \leq V_{DD}$ (Volt)

UART : J2:pin-1,2 : 38,400BPS, 8bit, No parity, 1 stop bit

I2C (Option) : Slave mode only, Internal pull up resistor, Support standard up to 100kHz clock

J1	Description
1/3	VCC
2/4	GND

J2	Description
1	TTL RXD (← CPU of Master Board)
2	TTL TXD (→ CPU of Master Board)
3	I2C SCL (option)
4	I2C SDA (option)
5	GND
6	Reserved
7	H/W based ACDL initiation
8	Reserved
9	10 min. Manual Calibration (H/W based MCDL, Low Active)
10	Reset (Low Active)

※ J1, J2 : 2mm pitch 2-row socket connector

Pin Map with J5 (8PIN) Side hole of IoT-S300E

J5	Description
1	SCL (option)
2	SDA (option)
3	TTL TXD
4	TTL RXD
5	ACDL
6	10 min. Manual Calibration(H/W based MCDL, Low Active)
7	GND
8	VCC

※ J5 : 1.27mm pitch Side hole

Dimensions unit : mm

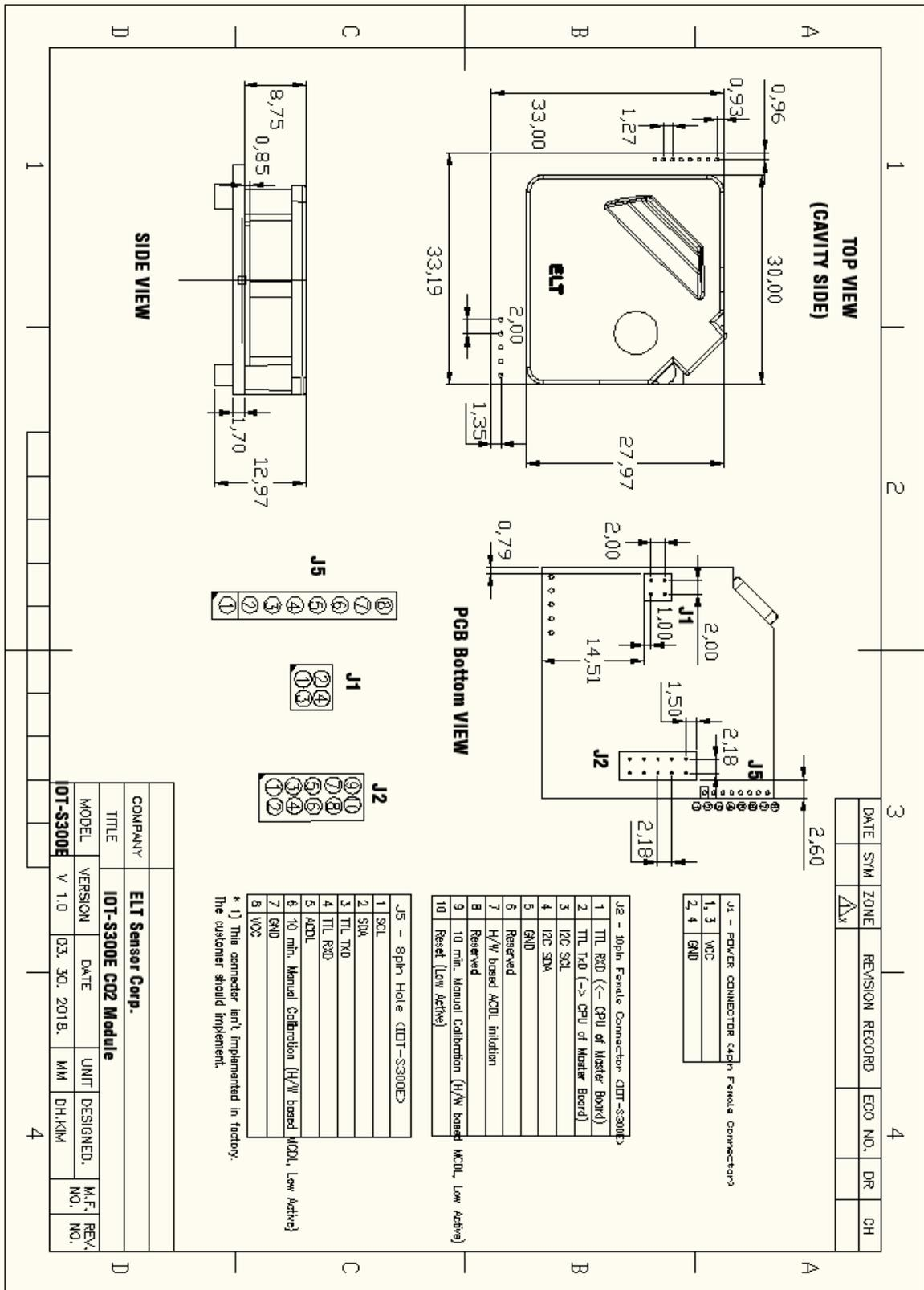

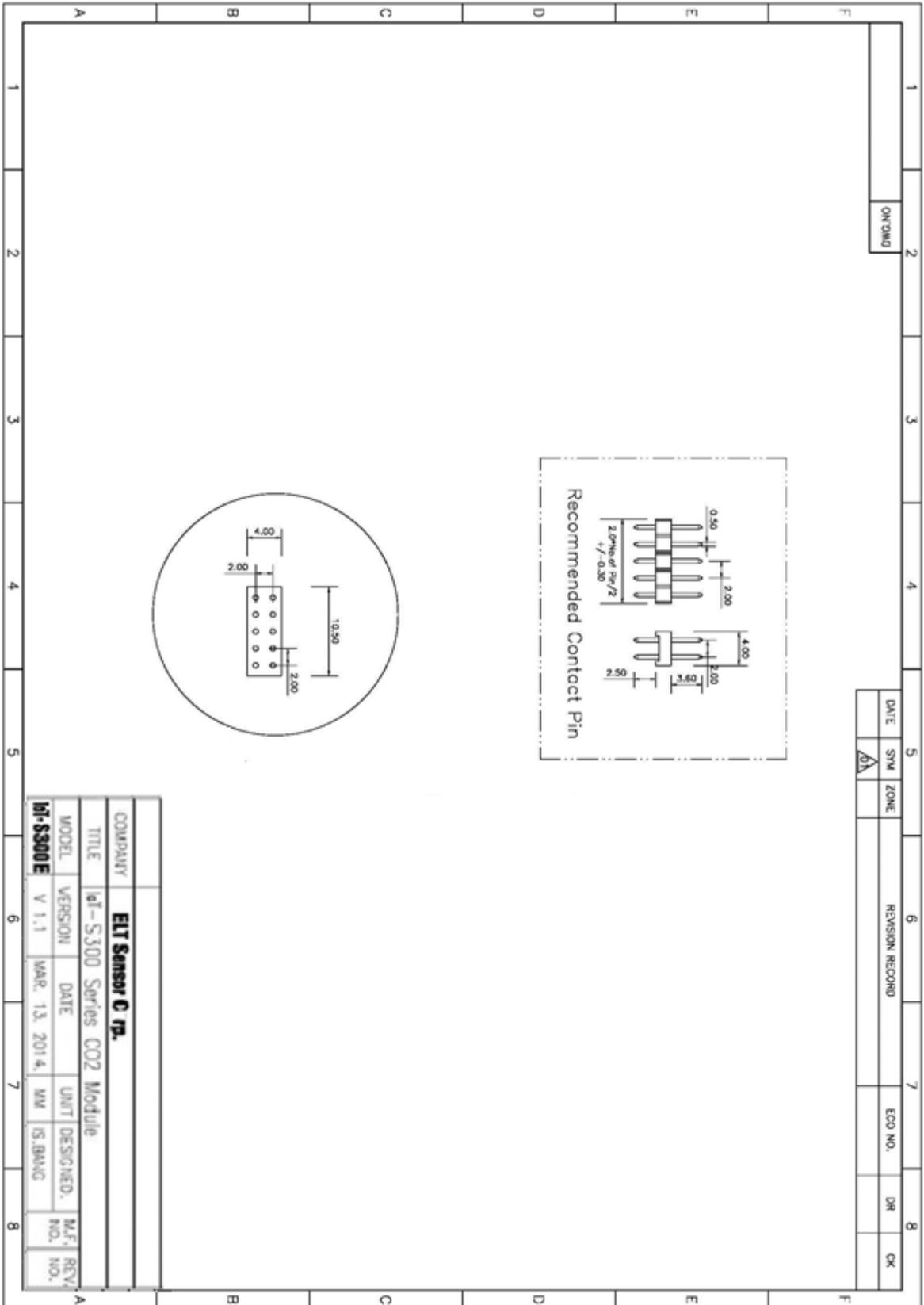

DATE	SYM	ZONE	REVISION RECORD	ECO NO.	DR	CK
	Δ/A					

COMPANY	ELT Sensor Corp.					
TITLE	EL-S300 Series CO2 Module					
MODEL	VERSION	DATE	UNIT DESIGNED.	M.F. NO.	REV. NO.	
EL-S300E	V 1.1	MAR. 13, 2014	MM	IS.BANG		

Output Descriptions

UART Descriptions

Data Transmit

Interval : 3 seconds

Handshake protocol : None (Data is transmitted to outer device periodically)

Data Format

D5	D4	D3	D2	D1	BL	'p'	'p'	'm'	CR	LF
----	----	----	----	----	----	-----	-----	-----	----	----

D1 ~ D5	5 byte CO2 density string
BL	Blank: 0x20
'ppm'	'ppm' string
R	Carriage return : 0x0D
LF	Line feed : 0x0A

EX) In case 1,255 ppm, 0x20 0x31 0x32 0x35 0x35 0x20 0x70 0x70 0x6D 0x0D 0x0A '1,255 ppm
<CR><LF>'

I2C Communication (Only Slave Mode Operation) - Option

Internal pull up resister

Slave Address: 0x31, Slave Address Byte: Slave Address(0x31) 7 Bit + R/W 1 Bit

Bit7	Bit6	Bit5	Bit4	Bit3	Bit2	Bit1	Bit0
0	1	1	0	0	0	1	R/W Bit

R/W Bit : Read = 1/Write = 0

When reading the data, Slave Address Byte is 0x63, When writing the data, Slave Address Byte is 0x62.

Block Diagram

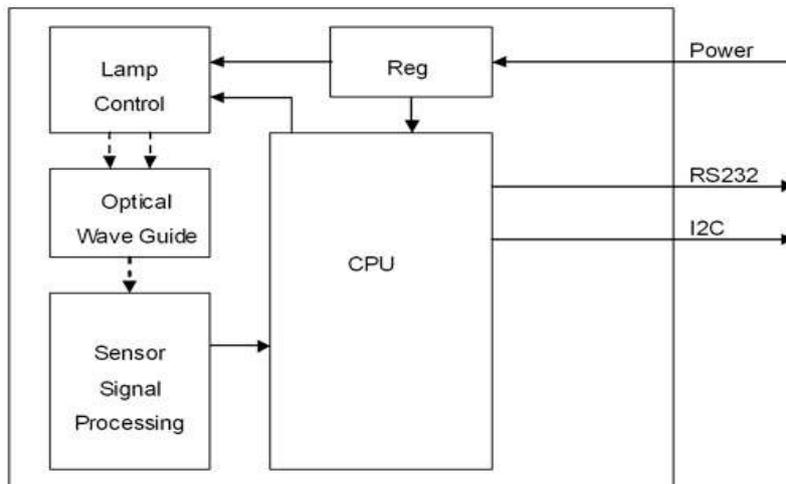

Transmission Sequence in Master

- 1) I2C Start Condition
- 2) Write Command(Slave Address + R/W Bit(0) = 0x62) Transmission and Check Acknowledge
- 3) Write Command(ASCII 'R' : 0x52) Transmission and Check Acknowledge
- 4) I2C Stop Command
- 5) I2C Start Command
- 6) Read Command(Slave Address + R/W Bit(1) = 0x63) Transmission and Check Acknowledge
- 7) Read 7 Byte Receiving Data from Module and Send Acknowledge
(Delay at least 1ms for reading each byte)

Configuration	CO ₂	reserved	reserved	reserved	reserved
1 Byte	2 Byte	0x00	0x00	0x00	0x00

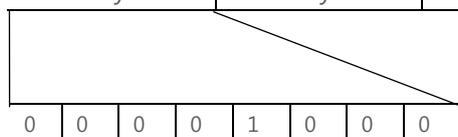

ACDL function (Automatic Calibration Function in Dimming light with period)

Method 1. **TRB-100ST (Test and Recalibration Board)** is purchasable to executable, letting sensor be located at ambient air-flow condition and execute by moving jumper following Manual, which is downloadable on the website.

ACDL pin level	MCDL pin level	Status	Notes
Low	High	ACDL mode	Automatic Recalibration mode monthly after 3 days since power-on, compensating the dimming effect of light source.

Method 2. **EK-100SL (Evaluation kit, with Emulation program ‘ELTWSO’)** or DK-100 (Download Kit is available.

Method 3. IOT-S300EA, which has Periodic Automatic Re-Calibration software in sensor, is selectable for Indoor Air-Quality Monitoring which could face ambient status with period. (2day at first, and every week as default).

10' MCDL function (10 minute Manual Calibration Function in Dimming light)

Method 1. To activate MCDL function, let TTL Low signal to MCDL pin for 10 minutes while as ACDL pin kept high.

ACDL pin level	MCDL pin level	Status	Notes
High	Low	MCDL - Recalibration	Manual Recalibration mode – Sensor should be located in 400ppm environment for 10 minutes and ‘High’ signal to ACDL pin. Calibration should be done no later than 18 minutes.

Method 2. Let Sensor install on Jig Board (**TRB-100ST: Test and Recalibration Board**) with ambient air-flow condition and execute by moving jumper following Manual, which is downloadable on the website.

Method 3. Send string command set below to RXD-pin of Sensor on Emulation program. **EK-100SL (Evaluation kit, with Emulation program ‘ELTWSO’)** is available.

※ Specification of IoT-S300 Series could be changed without notice.