

REVISIONS					
REV	DATE	DESCRIPTION	BY	CHK	APPV
G3	11MAR11	REVISED PER ECO-11-005027	RK	HMR	
G4	24MAY2017	REVISED PER ECO-16-018096	RK	PO	

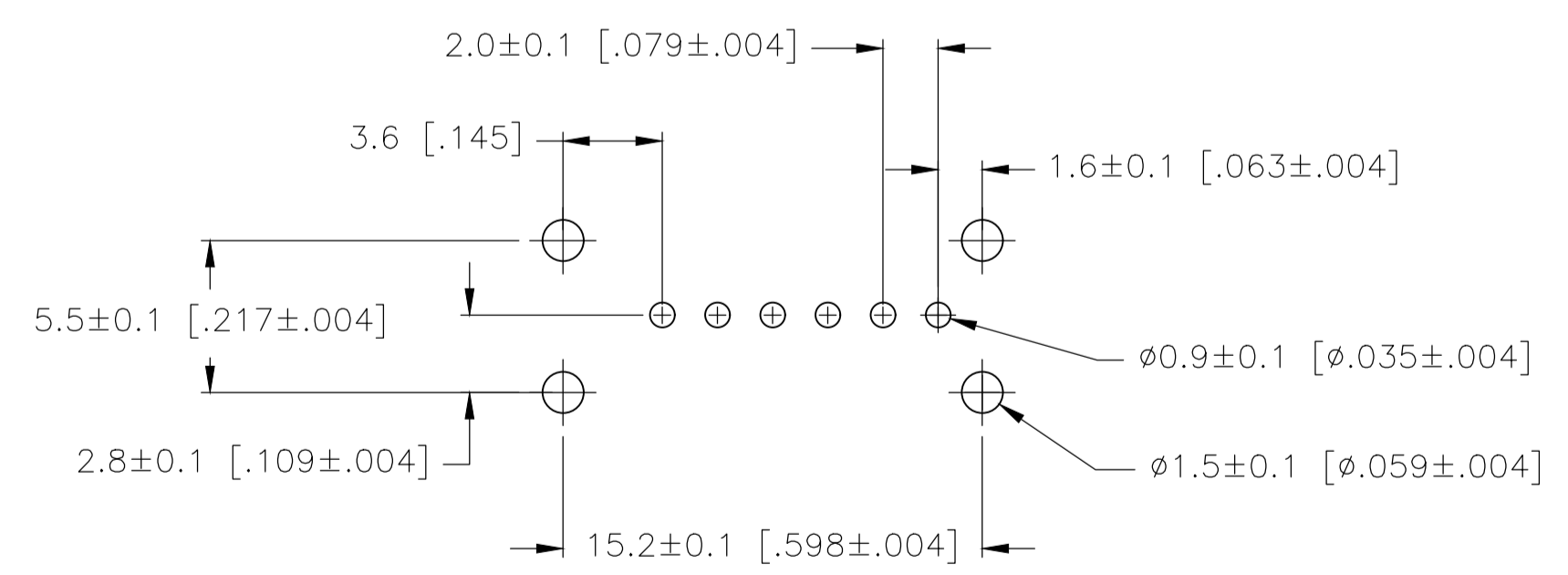

RECOMMENDED P.C. BOARD LAYOUT

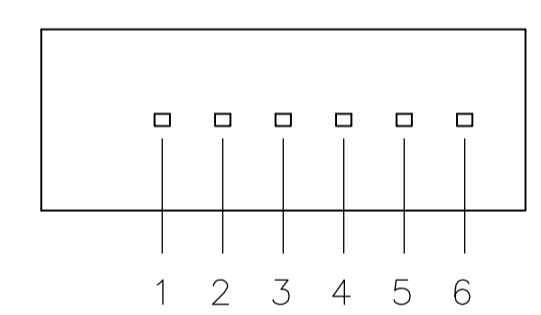
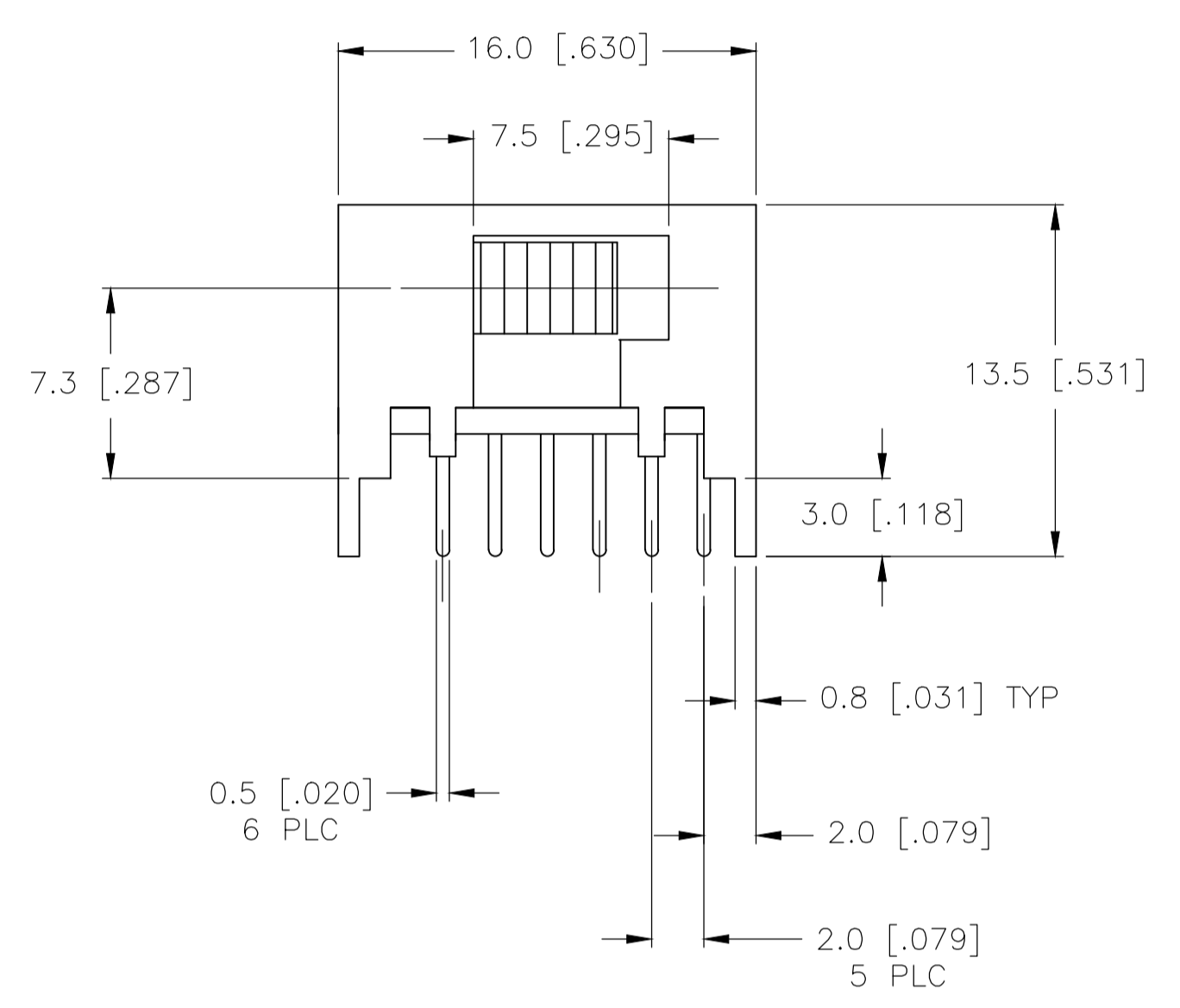
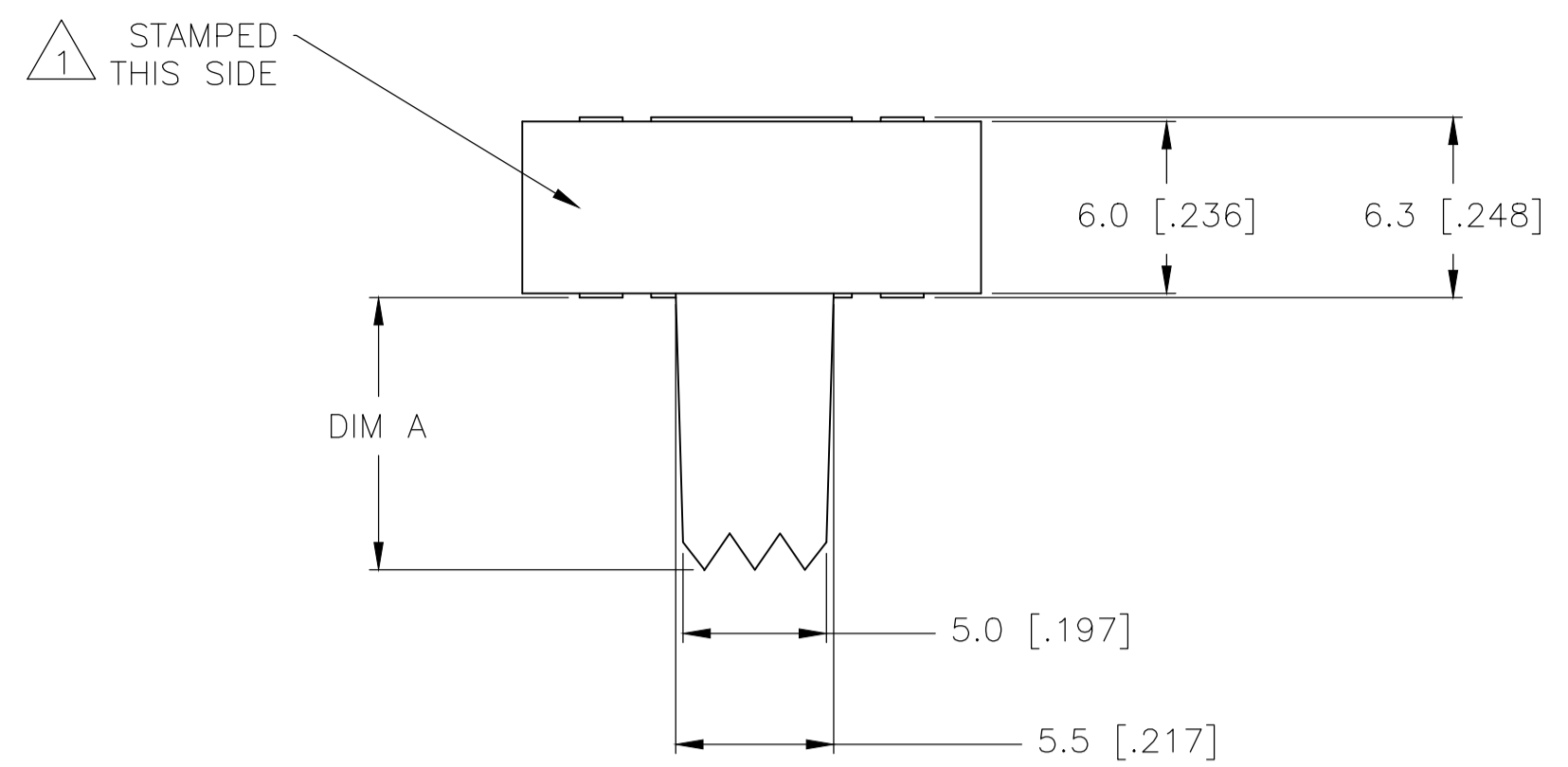
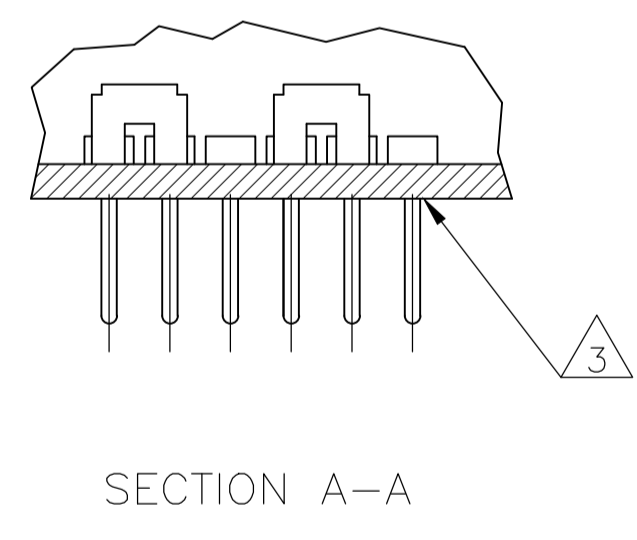
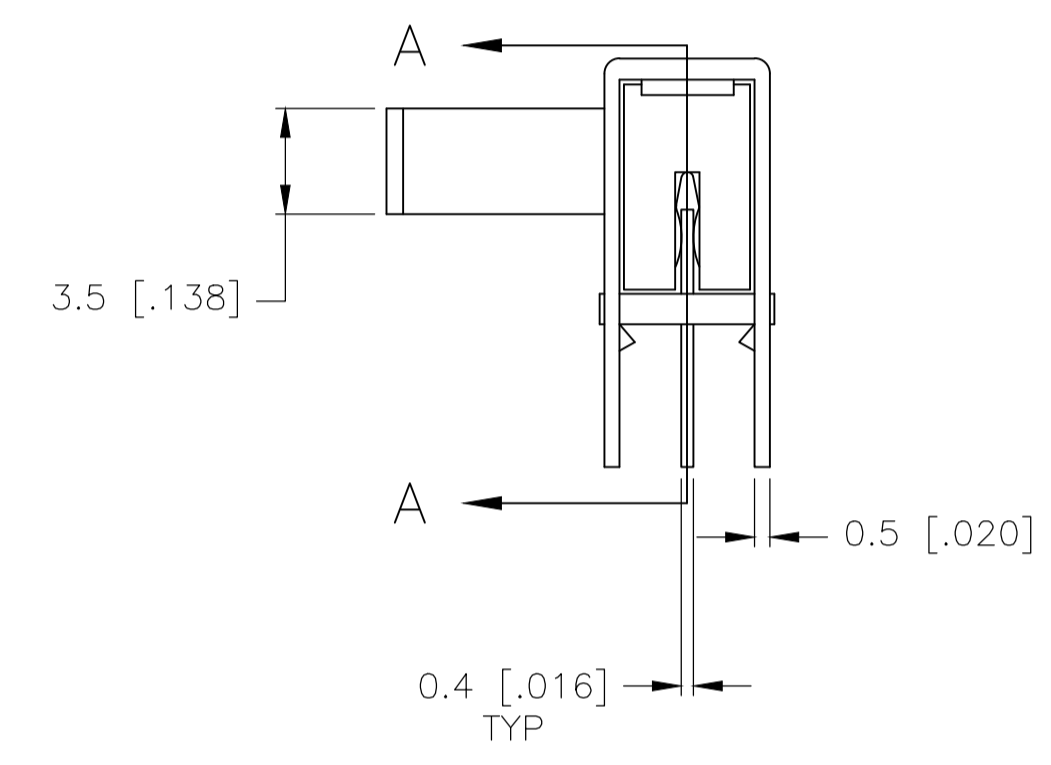

**SPECIFICATIONS**  
MAKE-BEFORE-BREAK

**MATERIALS:**  
 ACTUATOR- POM, UL94HB BLACK  
 TERMINAL BOARD- PHENOLIC LAMINATED SHEET, UL94HB, NATURAL  
 FRAME- STEEL, NICKEL PLATE  
 TERMINAL/FIXED CONTACT- COPPER ALLOY, GOLD OR SILVER OVER NICKEL PLATE  
 MOVING CONTACT- COPPER ALLOY, GOLD OR SILVER OVER NICKEL PLATE  
 DETENT BALL- STEEL  
 COIL SPRING- GALVANIZED SPRING WIRE  
 SEAL- EPOXY

**ELECTRICAL:**  
 CONTACT RATING- .4VA@20VDC OR PEAK AC (GOLD); 300mA@125V AC (SILVER)  
 INITIAL CONTACT RESISTANCE- 30 milliohm max.  
 FINAL CONTACT RESISTANCE- 100 milliohm max. (AFTER TEST)  
 INSULATION RESISTANCE- 1,000 Megohms min.  
 DIELECTRIC STRENGTH- 500V RMS@SEA LEVEL  
 LIFE EXPECTANCY- 15,000 CYCLES MIN.

**MECHANICAL:**  
 ACTUATION FORCE- 600+/-300 GRAMS  
 TRAVEL- 2.0 +/-0.50 (.079 +/-0.020)

**ENVIRONMENTAL:**  
 OPERATING TEMPERATURE- -20 TO +85 DEGREES C  
 STORAGE TEMPERATURE- -40 TO +100 DEGREES C  
 RESISTANCE TO SOLDER HEAT PER 109-202, CONDITION B  
 SOLDERABILITY PER EIA-364-52, CLASS 2, CATEGORY 1, 95% MIN COVERAGE

**NOTES:**

- 1 COUNTRY OF ORIGIN AND TE CONNECTIVITY LOGO LOCATED APPROXIMATELY AS SHOWN
- 2 ALL MATERIALS AND FINISHES SHALL COMPLY WITH EU DIRECTIVE 2002/95/EC OF 27JAN2003 (ROHS)
- 3 ANTI SOLDER WICK SEAL AT TERMINAL TO BOARD INTERFACE
- 4 ALL PERFORMANCE TESTING WAS DONE IN ACCORDANCE TO TE CONNECTIVITY SPECIFICATION 102-2469

STATUS	PART NO.	T&B PART NO.	PLATING	A	123456	123456
OBSOLETE	1571630-3	MSS2250RG04	GOLD	9.5(.374)	2 TO 1 5 TO 4	2 TO 3 5 TO 6
	1571630-2	MSS2250R04	SILVER	9.5(.374)	2 TO 1 5 TO 4	2 TO 3 5 TO 6
OBSOLETE	1571630-1	MSS2250RSA04	SILVER	3.2(.126)	2 TO 1 5 TO 4	2 TO 3 5 TO 6

TERMINALS CONNECTED WHEN SLIDE IS IN POSITION SHOWN.

THIS DRAWING IS A CONTROLLED DOCUMENT. DIN R BROWN 20DEC05. CHK M SARVER 20DEC05. APVD M SARVER 20DEC05. NAME SLIDE SWITCH, MSS 2250R SERIES, DP-DT, RIGHT ANGLE. PRODUCT SPEC. APPLICATION SPEC. SIZE A1. CAGE CODE 00779. DRAWING NO. 1571630. WEIGHT. RESTRICTED TO. MATERIAL. FINISH. WEIGHT. A1 00779 1571630. CUSTOMER DRAWING. SCALE 4:1. SHEET 1 OF 1. REV G4.