

1. General description

PTN5100 is a single port USB Type-C Power Delivery (PD) PHY and Protocol IC that provides Type-C Configuration channel interface and USB PD Physical and Protocol layer functions to a System PD Port Policy Controller (Policy Engine and Device Policy Manager, Alternate mode controller). It complies with USB PD[1] and Type-C[2] specifications and delta updates of PD spec. This IC is targeted for a wide range of platforms (Standard Notebook PCs, Desktop PCs, Chromebooks, Tablets, Convertibles, Smart phones) and PC Accessories (e.g. Docks, Monitors, Cable adapters etc.) applications. PTN5100 is architected to deliver robust performance, compliant behavior, configurability and system implementation flexibility that are essential to tide over interoperability and compliance hurdles in the platform applications.

PTN5100 can support system realization of the following PD roles: (i) Provider (P) only, (ii) Provider/Consumer (P/C) (iii) Consumer only (C) (iv) Consumer/Provider (C/P). Further, it can be register programmed to operate in Type-C specific Upstream Facing Port (UFP), Downstream Facing Port (DFP) or Dual Role Port (DRP) role.

PTN5100 implements VCONN low RON switch with register programmable Forward Current protection feature. The VCON switch also provides Reverse current protection feature to detect reverse current flow into the system whenever (inductive or) charged cable is unplugged from the connector.

PTN5100 operates from platform power supply VDD, or it can also be powered from USB power VBUS directly, which is especially required for operation under Dead Battery (DB) condition and certain platform use cases. The host interface operates on VIO supply to facilitate interfacing to systems that use IO supply rail different from VDD supply rail.

It provides SPI/I2C interface for system host control/status update. The interface choice is pre-configured in NXP factory.

PTN5100 is available in a small footprint package option: HVQFN20 4 mm x 4 mm, 0.5 mm pitch.

Remark:

1. The term 'EC' is used interchangeably with 'Embedded Controller', 'AP', 'Application Processor' or 'System Management Controller, SMC' or System Host Controller throughout this document.
2. The terms 'PMIC', 'Power Management Interface Controller', 'Charger IC' are used interchangeably throughout this document.

2. Features and benefits

2.1 USB PD and Type-C Features

Complies with USB PD[1] and USB Type-C[2] specifications.

- Supports implementation of various system PD roles: P, P/C, C, C/P
- Supports Type-C role configurability
 - ◆ Type-C role (DFP, UFP, DRP) is Non-Volatile Memory (NVM) and register programmable based on OEM platform requirements
 - ◆ Implements UFP role pull down behavior to handle dead battery condition on battery powered platforms
 - ◆ Supports register programmable and variable 'Rp' indication (for DRP/DFP usage and accessory detection)
 - ◆ Implements 'Rd' indication on CC pin (for Device side implementation)
 - ◆ CC detection/indication scheme based on Type-C role
 - ◆ Indication of orientation detection via CC_ORIENT pin and status register(s)
 - ◆ Debug and Audio Accessory detection and indication in status register(s)
- Cooperatively works under the control of Policy controller MCU for power delivery negotiation and contract(s), Alternate mode and VDM exchanges
 - ◆ Implements BMC (de)coding, 4B5B symbol (de)coding, CRC generation/checking, PD packet assembling/disassembling including Preamble, SOP, EOP, Good CRC response, Retries, Hard and Cable resets
 - ◆ PD PHY and Protocol layer interface control and status update handled via SPI/I2C interface
- SOP* Configurability
 - ◆ Register programmable to generate and receive SOP, SOP', SOP'-debug, SOP'', SOP''-debug" in DFP/DRP (host use case)
 - ◆ Register programmable to receive and respond on SOP, SOP'-debug and SOP''-debug commands
- Supports low RON VCONN switch with enable/disable (Hi-Z) support
 - ◆ Capable of maximum current delivery of 1 A over 2.7 V to 5.5 V
 - ◆ Supports register programmable Forward current protection control
 - ◆ Supports register programmable Reverse current protection

2.2 System protection features

- Back current protection on all pins when PTN5100 is unpowered
- CC1 and CC2 pins are 5.5 V tolerant
- VBUS pin and VBUS power path MOSFET enable pins are 28 V tolerant

2.3 General

- Delivers (active LOW enable) gate control signals for PMOS Power MOSFETs on VBUS source and sink power paths
- Provides dedicated IO pin (CC_ORIENT) for indicating Cable/plug orientation and IO pin (DBGACC_FOUND) for indicating Debug accessory detection
- Delivers up to 30 mA (max) for powering Policy controller MCU
- Supports SPI slave interface (SPI modes 1 and 2 supported) up to 30 MHz

- Supports I2C slave interface standard mode (100 kHz), Fast mode (400 kHz) and Fast mode plus (1 MHz)
- I2C Device slave address programmable up to 3 values
- Supports 3.3 V or 1.8 V capable I²C-bus or SPI interface
 - ◆ Supports register access - device configuration, control and status/interrupt interfacing through Slave I²C-bus interface
- Power supplies - VDD (3.3 V ±10 %) or VBUS
 - ◆ Tolerant up to 28 V on VBUS and operational up to maximum of 25 V on VBUS
- Operating temperature -20 °C to 85 °C
- ESD 8 kV HBM, 1 kV CDM
- Package: HVQFN20 4 mm × 4 mm, 0.5 mm pitch

3. Applications

- PC platforms: Notebook PCs, Desktop PCs, Ultrabooks, Chromebooks
- Tablets, 2:1 Convertibles, Smartphones and Portable devices
- PC accessories/peripherals: Docking, Mobile Monitors, Multi-Function Monitors, Portable/External hard drives, Cable adaptors, Dongles and accessories, etc.

4. Ordering information

Table 1. Ordering information

Type number	Topside marking	Package		
		Name	Description	Version
PTN5100BS	5100	HVQFN20	plastic thermal enhanced very thin quad flat package; no leads; 20 terminals; body 4 × 4 × 0.85 mm ^[2]	SOT917-4
PTN5100ABS	510A	HVQFN20	plastic thermal enhanced very thin quad flat package; no leads; 20 terminals; body 4 × 4 × 0.85 mm ^[3]	SOT917-4

[1] Total height after printed-circuit board mounting <=1 mm (maximum)

[2] Supported system interface - SPI

[3] Supported system interface - I²C

4.1 Ordering options

Table 2. Ordering options

Type number	Orderable part number	Package	Packing method	Minimum order quantity	Temperature
PTN5100BS	PTN5100BSMP	HVQFN20	Reel 13" Q2/T3 *standard mark SMD dry pack	6000	T _{amb} = -20 °C to +85 °C
PTN5100ABS	PTN5100ABSMP	HVQFN20	Reel 13" Q2/T3 *standard mark SMD dry pack	6000	T _{amb} = -20 °C to +85 °C

5. Block diagram

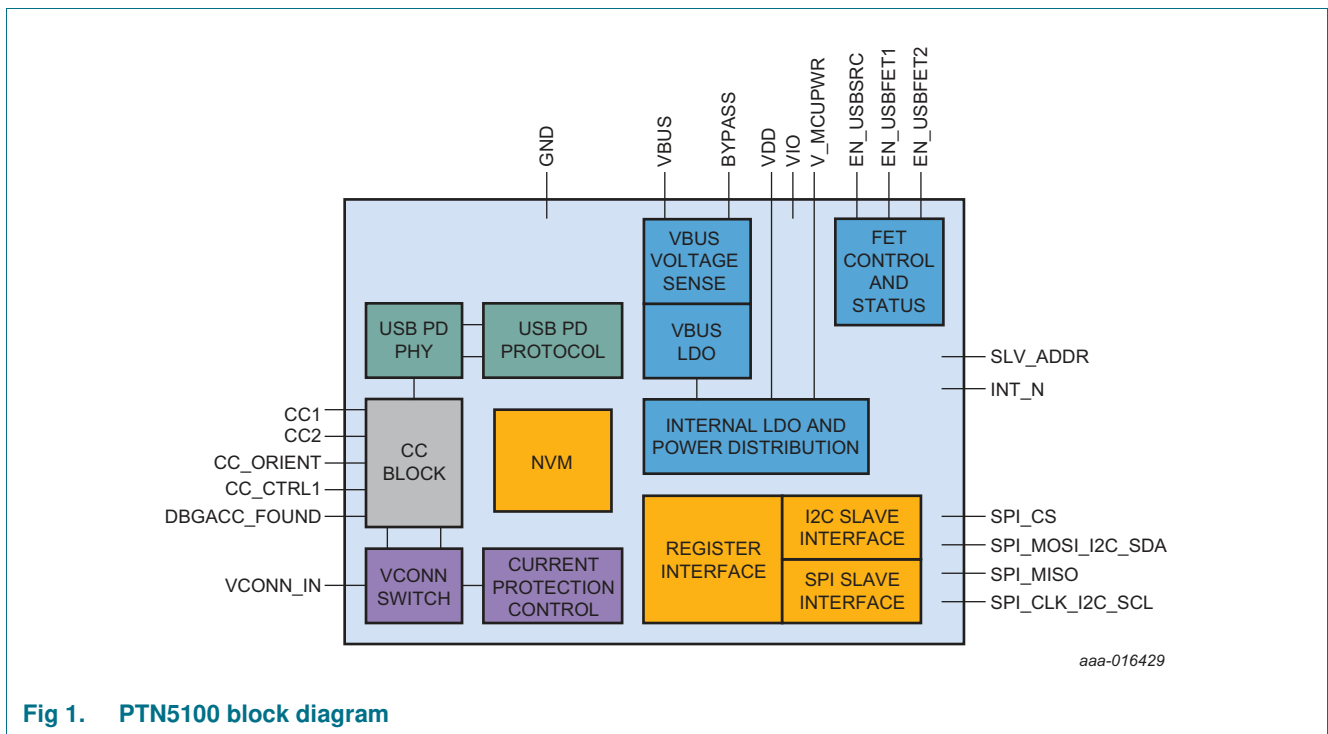
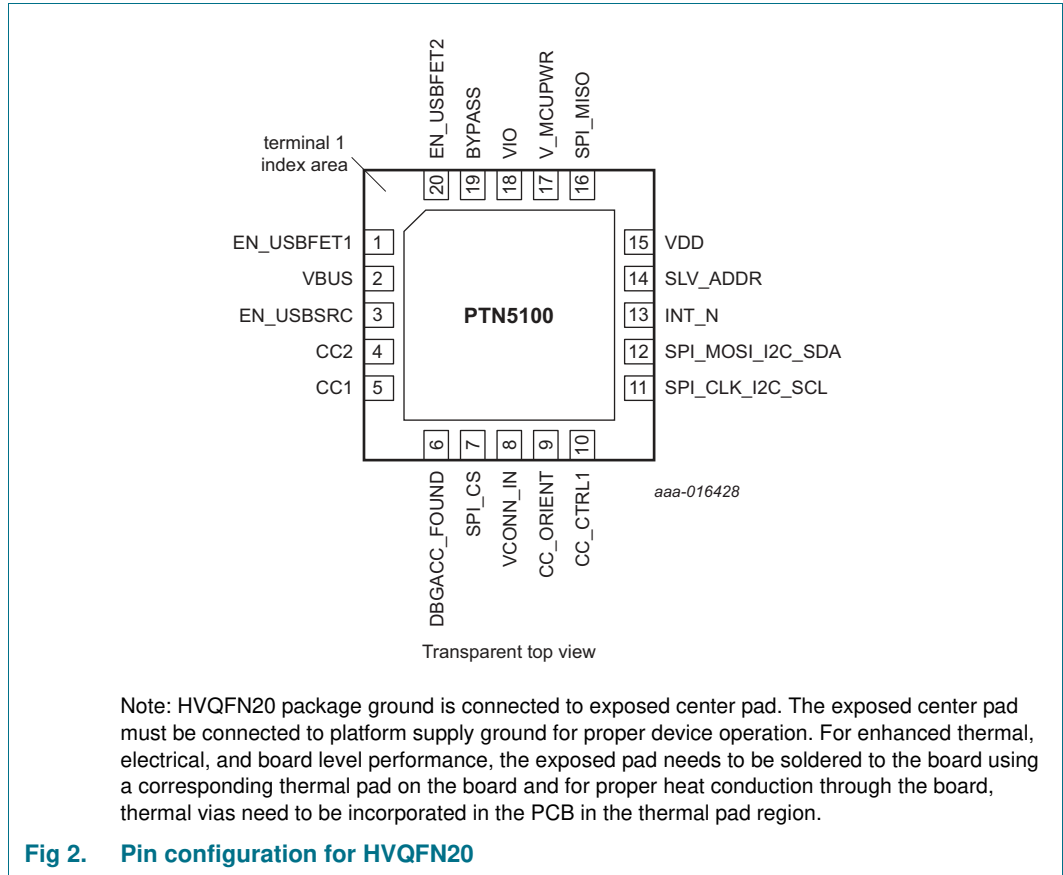

Fig 1. PTN5100 block diagram

6. Pinning information

6.1 Pinning



6.2 Pin description

Table 3. Pin description

Symbol	Pin	Pin direction	Pin Type	Description
EN_USBSRC	3	Output	Open drain	<p>USB PD VBUS Source Power path PMOS FET gate Active Low enable.</p> <p>At default/POR, this pin is Hi-Z; PTN5100 drives this pin LOW based on Type-C connection state and/or policy controller MCU command.</p> <p>The pin status can be read in the internal register(s).</p>
EN_USBFET1	1	Output	Open drain	<p>USB PD VBUS Source or Sink Power path PMOS FET gate Active Low enable.</p> <p>At default/POR, this pin is Hi-Z; PTN5100 drives this pin LOW based on Type-C connection state and/or policy controller MCU command.</p> <p>The pin status can be read in the internal register(s).</p>
EN_USBFET2	20	Output	Open drain	<p>USB PD VBUS Source or Sink Power path PMOS FET gate Active Low enable.</p> <p>At default/POR, this pin is Hi-Z; PTN5100 drives this pin LOW based on policy controller MCU command.</p> <p>The pin status can be read in the internal register(s).</p>
CC1	5	IO	Custom IO	<p>Type-C Configuration channel #1</p> <p>TVS or similar protection diode (e.g. PESD5V0S1USF, PESD5V0S1UL, etc.) shall be used to protect the CC1/2 pins from overshoot/undershoot during cable plug/unplug and cable discharge events.</p>
CC2	4	IO	Custom IO	<p>Type-C Configuration channel #2</p> <p>TVS protection diode (e.g. PESD5V0S1USF, PESD5V0S1UL, etc) shall be used to protect the CC1/2 pins from overshoot/undershoot during cable plug/unplug and cable discharge events.</p>
CC_ORIENT	9	Output	CMOS IO on VIO power rail	<p>This pin indicates Type-C cable plug orientation.</p> <p>The pin's polarity is inverted at power-on reset and the PD policy controller MCU has to initialize PTN5100D before the pin level is valid. After the initialization, the pin indicates orientation as follows:</p> <ul style="list-style-type: none"> LOW = Normal plug orientation (CC communication on CC1) HIGH = Reverse plug orientation (CC communication on CC2) <p>Default pin value is LOW even if there is no connection or normal plug connection</p>
CC_CTRL1	10	Input	Analog Input	<p>Input to indicate whether to present 'Rd' or Open on CC pin under Unpowered condition</p>
DBGACC_FOUND	6	Output	CMOS IO on VIO power rail	<p>Indicates the presence of Type-C Debug accessory</p> <p>Default/POR value is LOW</p>
VCONN_IN	8	Input	Power	<p>VCONN power input from system side</p>

Table 3. Pin description ...continued

Symbol	Pin	Pin direction	Pin Type	Description
SPI_MOSI_ I2C_SDA	12	IO	Open drain IO (I2C mode) referenced to VIO voltage V_MCUPWR power rail (SPI mode)	Dual purpose pin. In I2C slave mode, this serves as I2C data input/output (open drain) In SPI slave mode, this pin serves Master Output Slave Input function (push pull CMOS IO)
SPI_MISO	16	Output	V_MCUPWR rail	This serves Master Input Slave Output function of SPI interface
SPI_CLK_I2C_SCL	11	Input	Open drain IO (I2C mode) referenced to VIO voltage V_MCUPWR power rail (SPI mode)	Dual purpose pin. In I2C slave mode, this serves as I2C clock input (open drain). In SPI slave mode, it serves as SPI clock input pin
SPI_CS	7	Input	V_MCUPWR rail	This pin provides SPI chip select Input
INT_N	13	Output	Open drain	Level triggered interrupt. Open drain output; This pin needs to be externally pulled up VIO. This pin is usable only when VDD is valid
SLV_ADDR	14	Ternary input	V_MCUPWR rail	Ternary slave address (I2C) pin
V_MCUPWR	17	Output	Power	This pin delivers current up to 30 mA (max) to policy controller MCU. External supply de-coupling capacitor(s) (2.2 μF ±10 % ceramic capacitor) are required
VIO	18	Input	Power	IO domain power supply. External supply de-coupling capacitor(s) are required
VBUS	2	Input	Power	VBUS power supply. External supply de-coupling capacitor(s) are required
VDD	15	Input	Power	Core domain power supply. External supply de-coupling capacitor(s) are required
BYPASS	19	Internal	Internal power rail	Internal power rail. A ceramic capacitor (2.2 μF ±10 %) is to be connected to this pin
GND	Center pad		GND	Ground Center pad

7. Functional description

PTN5100 is a 1-port USB Type-C PD Physical and Protocol Layer IC that can be used to realize single or multi-port USB Type-C PD and/or Alternate mode implementations. It complies with USB PD [1] and Type-C specifications [2]. PTN5100 supports the following use configurations:

1. On a System Host (single or multi-port configuration)
 - a. Controlled by a PD Policy controller and/or Alternate mode control MCU
 - b. Controlled by Embedded controller or Application processor
2. On a Device platform

- a. Controlled by a PD policy controller or Alternate mode control MCU or existing processor

On the host and device use cases, different PD roles are possible: (P), (P/C), (C), (C/P).

PTN5100 supports two levels of configurability and programmability:

- NVM configuration options - configurability in the factory through NVM configuration utility
- I2C/SPI register programmable - read/write accesses at application/Firmware (FW) level

PTN5100 can be partitioned into the following major functional blocks along with their respective interfaces:

- Type-C Configuration Channel functional block
- USB Power Delivery function
- VCONN Low RON Switch
- Power FET Enable Control
- MCU interface and Control

The following subsections describe the PTN5100 with its major functional blocks.

7.1 Type-C Configuration Channel functional block

Type-C Configuration Channel (CC) function operates as a front end to cable/plug interface.

PTN5100 can operate autonomously or under MCU control. To support use cases especially with autonomous mode, PTN5100 implements HW circuitry to perform the following operations:

- Applying 'Rp' or 'Rd' depending on the (NVM) configured role
- Detecting cable/plug connect and disconnect events
- Indicating Type-C current limit level in a system under DFP role
- Detecting the current level supported by remote end under UFP role
- Identifying plug orientation and indicating through CC_ORIENT pin
- Identifying Type-C Debug accessory detection and indicating through DBGACC_FOUND pin
- Updating event, interrupt and status registers and raising interrupt signal using INT_N pin

In order to provide reliable connect/disconnect event triggers, debouncing is also implemented as per [2].

PTN5100 allows for NVM configurability and/or register programmability to enable usage under different platform configurations.

7.2 USB Power Delivery Function

In general, the Embedded Controller (EC) or System Management Controller (SMC) handles the overall Application/Platform power management given the system states, battery status, etc. It reviews capabilities and status of various power providers (USB PD, AC-DC adapter, battery, docking, etc.) dynamically and determines a specific source for powering/charging the platform - the power source selection is an important and platform dependent aspect of Application power delivery scheme.

- For example, in some computing applications, EC plays a central role in controlling the various power sources including USB PD. To support this, PTN5100 and Policy controller MCU can be configured to negotiate and agree on power contract based on command/response exchanges with EC
- In several applications, EC may not even exist or EC wants to play a hands-off role. To support these applications, PTN5100 and Policy controller MCU can be configured to operate autonomously

In a Type-C PD implementation, the system partitioning involves the following parts:

- Port PHY and Protocol layer functions → PTN5100
- Port policy engine and device policy management, Alternate mode support → Discrete policy controller MCU
- System management → EC or SMC

PTN5100 implements USB PD PHY layer and HW intensive Protocol functions and it works along with a discrete MCU to implement Full PD functionality. The combined 2-chip system solution (PTN5100 and MCU) can be configured to support one or more of the following PD roles:

1. PD Consumer (C)
2. PD Consumer/Provider (C/P)
3. PD Provider (P)
4. PD Provider/Consumer (P/C)

The interface between PTN5100 and Policy controller MCU can be either SPI or I2C. PTN5100 provides a transparent set of commands and register interface for the MCU to control the operation and ensure safe/suitable system behavior/response. PTN5100 Application Programming guide [3] describes the register set supported for the PD control, status updates and operational control/sequences.

The policy controller MCU implements PD port policy layer as per [1]. The default PD power profiles are configured in the MCU and the EC could request for specific profile and PD contract based on platform application. The 2-chip solution can operate autonomously or under EC control.

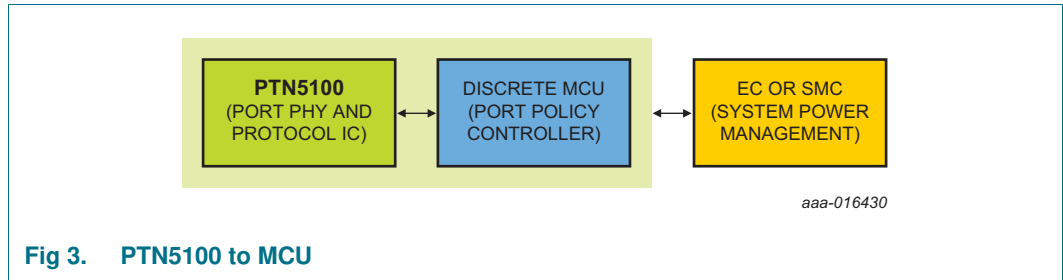

Fig 3. PTN5100 to MCU

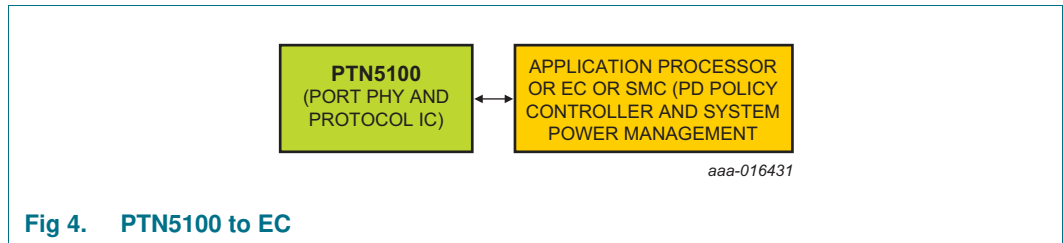

Fig 4. PTN5100 to EC

PTN5100 implements USB PD PHY layer function as follows:

- Slew rate controlled IO
- Bit transmission and data recovery
- Bi-phase Mark Coding
- 4B5B Line coding
- CRC computation and checking

It handles the following Protocol layer functions:

- Data Packetization and Extraction
- Good CRC Response
- Automated Retries
- Hard reset, Cable reset
- Tx and Rx buffer management

It handles both Transmit and Receive operation and it maintains dedicated TX and RX data buffers. To minimize chances of collision, PTN5100 checks the CC line before start of transmission. Once the data is transmitted or received, the I2C interface status is updated and MCU is interrupted.

BIST mode (Tx, Rx) is also supported.

Note: NXP is open to engage on Firmware licensing to give a head start to customers on USB PD Policy and Alternate mode Firmware front. Please contact NXP for further details.

7.3 VCONN Switch

Type-C specification defines a dedicated power pin VCONN_IN to deliver power to full featured cables, dongles and cable adapters.

PTN5100 implements very low RON switch that can deliver up to 1 A current. Depending on the pin over which CC communication is established, VCONN power is delivered into the other CC pin. With patented architecture, the switch implements Soft Start behavior to avoid heavy inrush current flow.

The VCONN switch is to be used only when VCONN_IN lies within the valid range (2.7 V to 5.5 V).

The VCONN switch can be enabled or disabled by Firmware. When in disabled condition, it presents Hi-Z condition. The switch implements two important features related to robustness:

- Forward Current Protection (FCP) that monitors over current condition (over current limit is register programmable) and trips the connection by disabling the switch
- Reverse Current Protection (RCP) that avoids reverse current flow back into the system due to inductive effects of cable unplug events

Further, both FCP and RCP circuitry shall be activated only when VCONN_IN is within valid range.

7.3.1 Forward Current Protection (FCP)

PTN5100 implements Forward current protection in VCONN switch that keeps monitoring for a current flow above the preconfigured level from the system side and whenever the threshold is exceeded, the switch is opened and an interrupt event is raised. The switch remains open until the port controller MCU reads the status and re-enables the switch.

7.3.2 Reverse Current Protection (RCP)

PTN5100 implements Reverse Current Protection in VCONN switch that watches for any instantaneous reverse current flow back into the system via VCONN and whenever the preconfigured threshold is exceeded, the switch is opened and an interrupt event is raised. The switch remains open until the port controller MCU reads the status and re-enables the switch.

7.4 Power FET control

PTN5100 implements three dedicated open drain IOs that can be used to control the external power MOSFETs and enable/disable VBUS source and sink power paths of the system. These are enabled or disabled based on PD power role (provider or consumer) of the Type-C interface. Based on PD negotiation and contract, the policy controller MCU enables/disables the specific power path (source FET or sink FETs).

- EN_USBSRC: This pin is used to enable/disable the power MOSFETs that corresponds to VBUS source (e.g. 5V regulated output). The FET enable can be configured and controlled through the register interface by the MCU. The pin status is monitored and updated in a status register.
- EN_USBFE1: This pin is used to enable/disable the power MOSFETs that corresponds to USB PD power from external power sources or delivering VBUS power to external peripherals. Its specific use as a VBUS source or sink path control is programmable. The FET enable can be configured and controlled through the register interface by the MCU. The pin status is monitored and updated in a status register.

- EN_USBFET2: This pin is used to enable/disable the power MOSFETs that corresponds to USB PD power from external power sources or delivering VBUS power to external peripherals. Its specific use as a VBUS source or sink path control is programmable. The FET enable can be configured and controlled through the register interface by the MCU. The pin status is monitored and updated in a status register.

7.5 MCU interface and control

PTN5100 works along with policy controller MCU to realize USB PD functionality and/or Alternate mode support. The MCU can control and interface with PTN5100 through a dedicated I2C/SPI interface. In a given system implementation, only one of the two interfaces (I2C, SPI) can be used. This selection can be static configured via NVM.

PTN5100 provides up to three I2C slave address combinations based on ternary pin (SLV_ADDR) setting as per the table below.

Table 4. I2C slave address combinations

SLV_ADDR pin	Device address (Write/read)
GND	0xE0/0xE1
VDDIO	0xE4/0xE5
Unconnected	0xE8/0xE9

7.5.1 I²C-bus interface

PTN5100 has a slave I2C interface through which it provides a mechanism for control and status interaction/communication with the MCU. It supports Standard mode, Fast mode and Fast mode plus.

7.5.1.1 I2C writes

The following figure shows the basic protocol for I2C writes. A 16-bit offset is used to address each register.

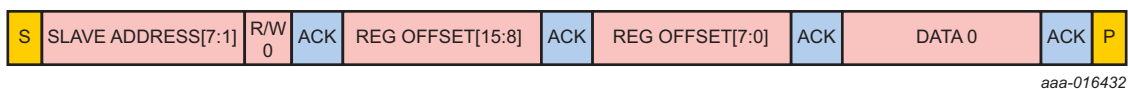

Fig 5. I2C writes

7.5.1.2 I2C reads

The following figure shows the basic protocol for I2C reads. They start off like I2C writes by specifying a 16-bit register offset. This is followed by a repeat start condition, the Slave Address (Read), and the read data.

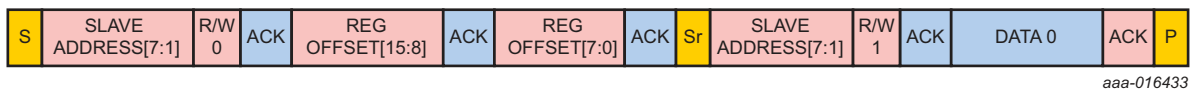

Fig 6. I2C reads

7.5.1.3 I2C address auto-incrementing

Bursts are allowed during writes and reads. Bit 15 of the register offset is the auto-increment indication. If '0' then the internally generated MMIO address will not increment with each data byte. If '1', then the address will increment with each data byte.

A detailed description of the I²C-bus specification, with applications, is given in user manual UM10204, "I²C-bus specification and user manual" [4]. Referring to I2C protocol, PTN5100 positively acknowledges all 256 register offset addresses, though there are certain undefined address offsets.

7.5.2 SPI interface

PTN5100 provides an SPI slave interface as well. It supports SPI modes 1 and 2. This interface exposes same register interface as that of I2C. Its main advantage is faster command and data transport and relaxes MCU response time/latency requirements.

7.5.3 Register interface

PTN5100 Application programming guide [3] describes the various registers with their bit definitions, POR values and the various functions. Also, sample 'C' programs corresponding to various functions and operations are given. This guide can be used by the platform system architects to implement the EC firmware to control the operations with PTN5100. Refer to programming guide for more information. The register definitions are also described in the guide.

7.5.4 Relevant Interface pins - SLV_ADDR, SPI_CLK_I2C_SCL, SPI_MOSI_I2C_SDA, SPI_CS, SPI_MISO, INT_N

- SLV_ADDR is a ternary input pin that is used to support up to 3 slave PTN5100 devices on a given platform. This pin can be pulled to V_MCUPWR rail, left open or pulled to GND.
- While in SPI mode, SPI_CLK_I2C_SCL, SPI_MISO, SPI_MOSI_I2C_SDA and SPI_CS provide the necessary interface for connecting to SPI master controller on the MCU.
- While in I2C mode, SPI_CLK_I2C_SCL and SPI_MOSI_I2C_SDA are used for I2C clock and data interfacing to MCU
- INT_N pin is used to raise Active LOW level triggered interrupt signal to EC. PTN5100 processes various events and raises interrupt that require SMC intervention. Once all relevant events are processed by the MCU, the INT_N pin goes HIGH. At POR, this pin remains HIGH (when VIO is valid). The specific events that can generate the interrupt can be selected.

7.6 Power supplies

PTN5100 is designed to operate under various power supplies. It can operate under both normal battery and dead battery environments (while drawing power from VBUS). PTN5100 handles power supply transitions (VBUS, VDD) transparently and there is no specific power supply ramp requirement imposed on the system (between VDD and VIO rails) also.

The following table highlights the power supplies and operating conditions for PTN5100.

Table 5. Power supplies vs. operating conditions

Valid power supply input combination	Operational condition	Remarks
VDD, VIO	Normal powered condition (both battery based or non-battery based platforms)	All interfaces operational
VDD, VIO, VBUS	Normal powered condition; Host Platform may be powered/charged through VBUS simultaneously	All interfaces operational
VBUS, VIO(=V_MCUPWR)	Dead battery in battery based platforms or Normal powered condition under other platforms; Host Platform powered/charged through USB PD	All interfaces operational
VBUS	Dead battery operation; PTN5100 draws power from VBUS for its operation; Host Platform may be powered/charged through USB PD later	PTN5100 pins (dependent on VIO rail) are not operational

Remark: The Policy controller MCU is powered by PTN5100.

The relevant pins associated with this functional block are:

- VDD
- VIO
- VBUS
- V_MCUPWR
- BYPASS

8. PTN5100 - Use case view

Given that USB Power Delivery could address the requirements of a wide set of markets and product segments, PTN5100 is designed to work over a range of product categories, platform applications, use cases and usage roles. With its configurability, it can be serve the needs of both general and custom applications. Not limited to these but the following subsections illustrate a set the use cases of PTN5100.

8.1 System use cases

8.1.1 USB PD Provider/Consumer - Notebook/Ultrabook/Chromebook/Tablet PC

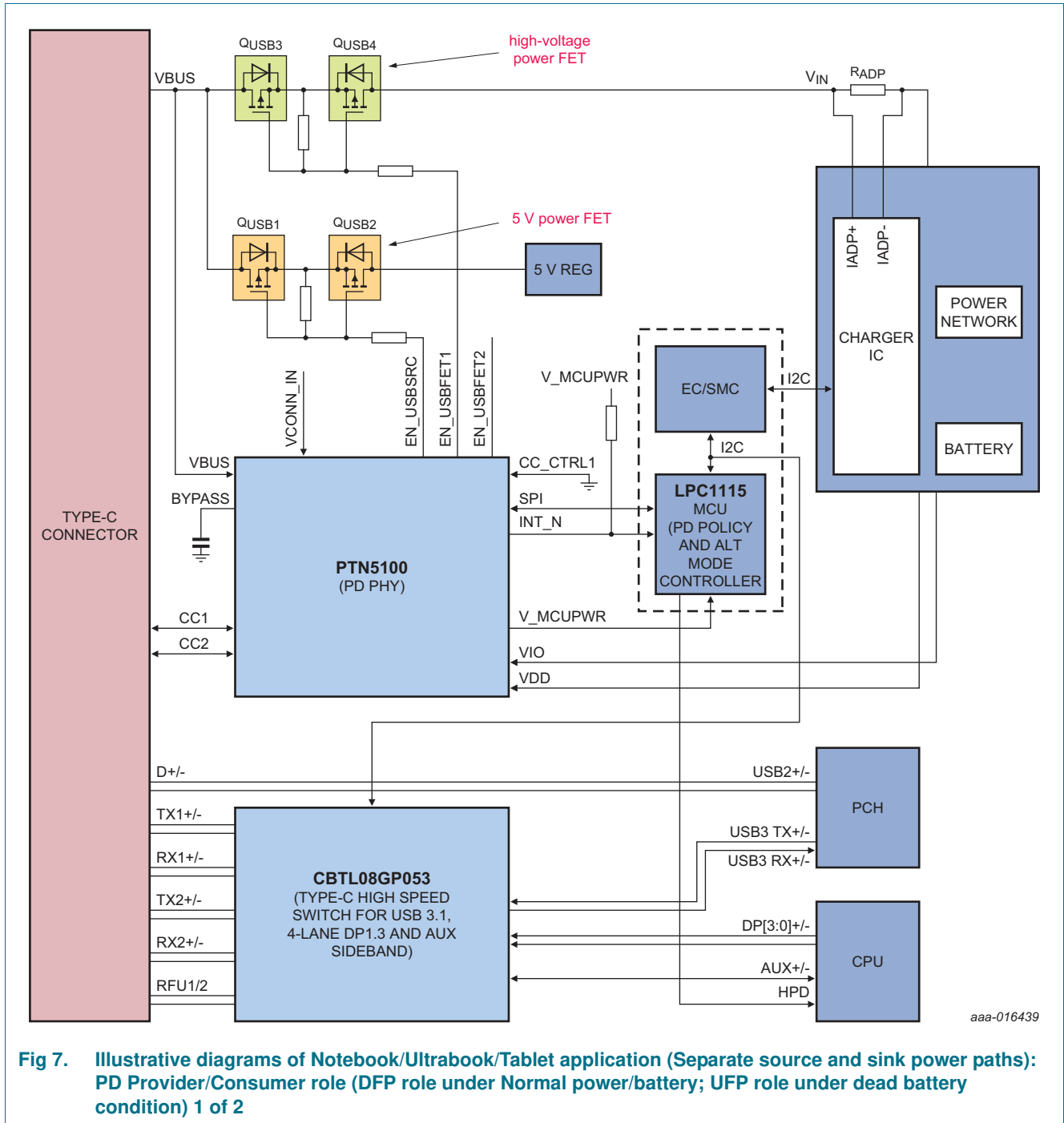
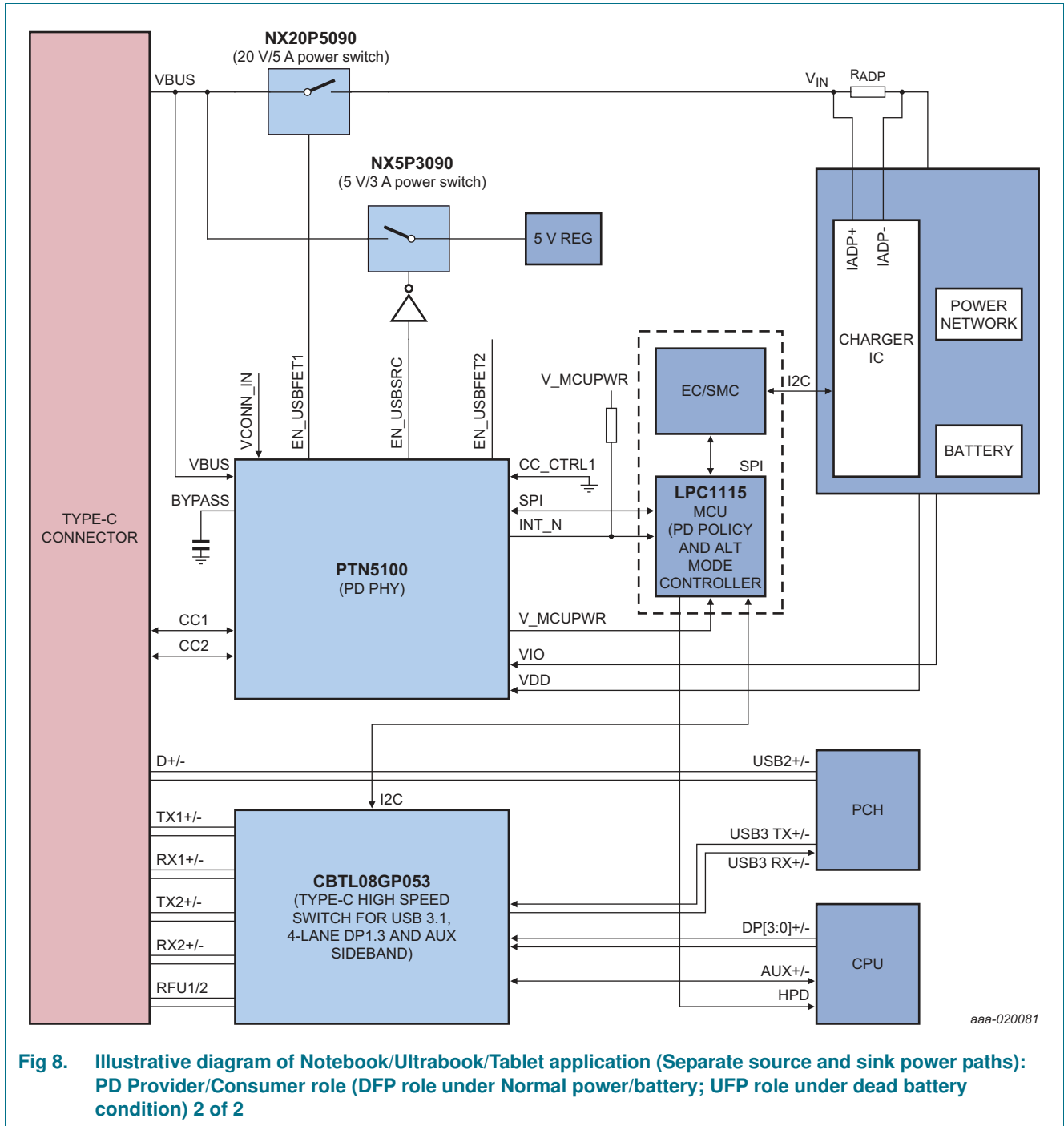

Fig 7. Illustrative diagrams of Notebook/Ultrabook/Tablet application (Separate source and sink power paths): PD Provider/Consumer role (DFP role under Normal power/battery; UFP role under dead battery condition) 1 of 2



aaa-020081

Fig 8. Illustrative diagram of Notebook/Ultrabook/Tablet application (Separate source and sink power paths): PD Provider/Consumer role (DFP role under Normal power/battery; UFP role under dead battery condition) 2 of 2

8.1.1.1 Brief description

In this illustration, the 2-chip solution (PTN5100 + Policy controller & Alternate mode MCU) is behind the Type-C receptacle and it is configured as a PD Provider/ Consumer. The EC interfaces with the Charger IC to configure at specific voltage/ current levels to perform battery charging and/or powering of the platform.

This application is expected to:

- Source VBUS 5 V (if not under dead battery)
- Charge from VBUS PD and AC barrel power, if applicable
- Source VCONN power

The EC communicates with controller MCU via an I2C bus and control the operations. The PTN5100 and MCU can operate autonomously or under the control of EC.

[Figure 7](#) and [Figure 8](#) illustrate the configurations with discrete MOSFETs and Power switches respectively. PTN5100 controls the power FETs/switch to determine charging (Green colored FETs/switch on VBUS power inputs) and 5 V VBUS power delivery (Orange colored FETs/switch on VBUS). If NXP5P3090 is used, then the Active HIGH switch enable control is required to be generated based on the EN_USBSRC control output.

An important aspect to consider here is that PTN5100 would indicate a 'Rd' pulldown (UFP) under dead battery condition and this enables the port partner to provide VBUS at 5 V (provided the port partner is capable of acting as DFP). However, after system starts up, role swap has to be performed to become DFP. This is handled by PTN5100 and MCU together.

CC_ORIENT and DBGACC_FOUND outputs can be used by the platform, if necessary.

8.1.2 USB PD Provider with Type-C receptacle - Desktop PC

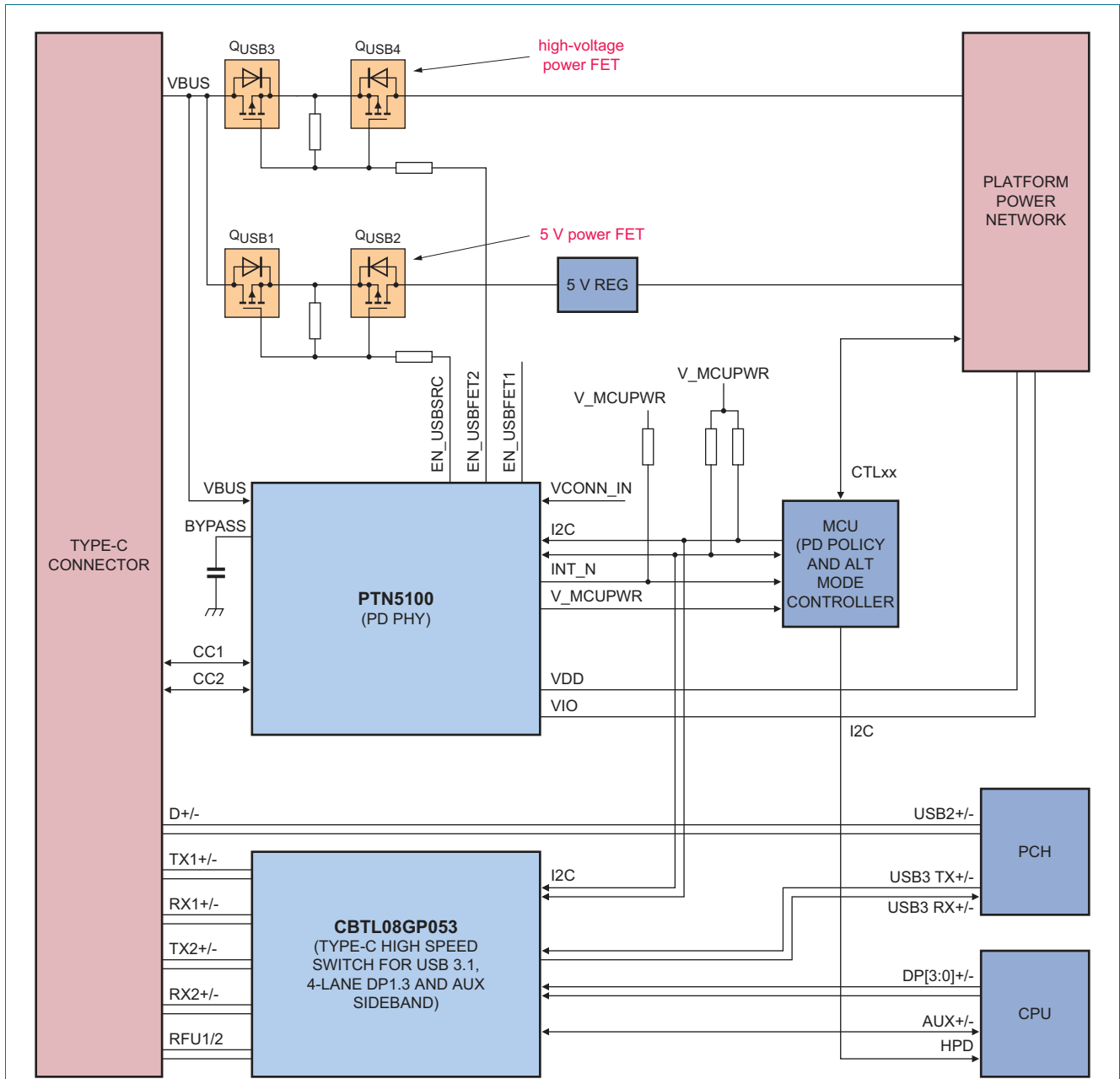

aaa-016440

Fig 9. Illustrative diagram of Desktop PC application (Source power paths and FETs/power switches): PD Provider only (DFP role under powered condition and open under unpowered condition) 1 of 2

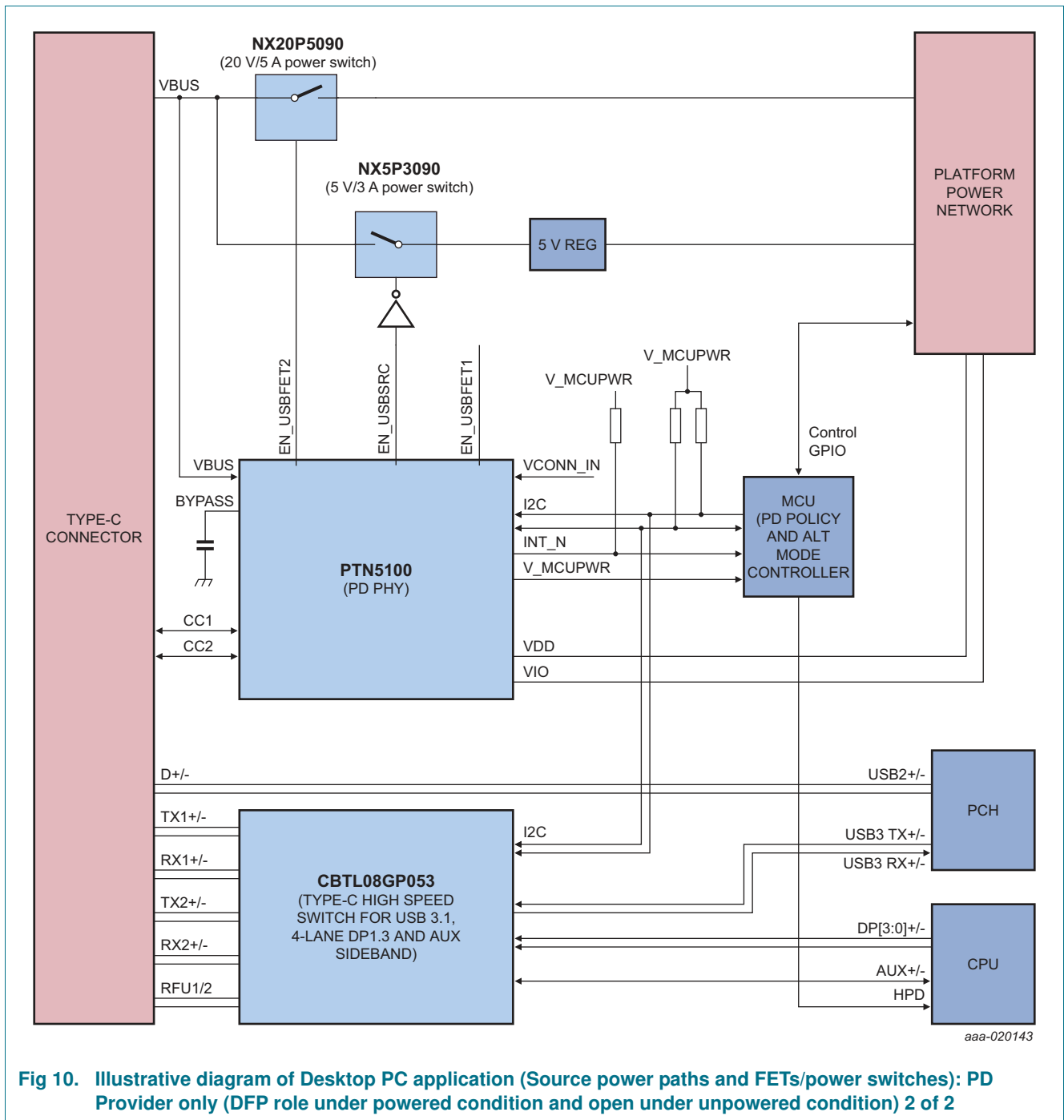

aaa-020143

Fig 10. Illustrative diagram of Desktop PC application (Source power paths and FETs/power switches): PD Provider only (DFP role under powered condition and open under unpowered condition) 2 of 2

8.1.2.1 Brief description

In this illustration also, the 2-chip solution (PTN5100+ Policy controller & Alternate mode control MCU) is behind Type-C receptacle and it is configured to act as a PD Provider (Autonomous mode) based on pre-configured Power profiles. The PC system uses the ATX or similar power supply and it can deliver power to all USB ports. In this diagram, there is no EC to interface with and so, the 2-chip solution (MCU and PTN5100) is configured for autonomous operation.

For USB ports, this application:

- Sources VBUS 5 V
- Sources USB PD power (specific wattage depends on the system application)
- Sources VCONN power

[Figure 9](#) and [Figure 10](#) illustrate the configurations with discrete MOSFETs and Power switches respectively. PTN5100 controls the power FETs/switches to VBUS 5V and PD power (Orange colored FETs/Switch). The handshake with power supply unit is dependent on OEM/ODM design.

An important aspect to consider here is that a Desktop PC does not have dead battery condition though it can be unpowered. If not powered, it presents 'Open' on CC pins. After power up initialization, PTN5100 would indicate 'Rp'. After PD negotiation, the Desktop platform could deliver higher voltage/current.

CC_ORIENT and DBGACC_FOUND connections can be used based on platform need.

8.1.3 USB PD Consumer/Provider (Smartphone use case) - Standalone PTN5100

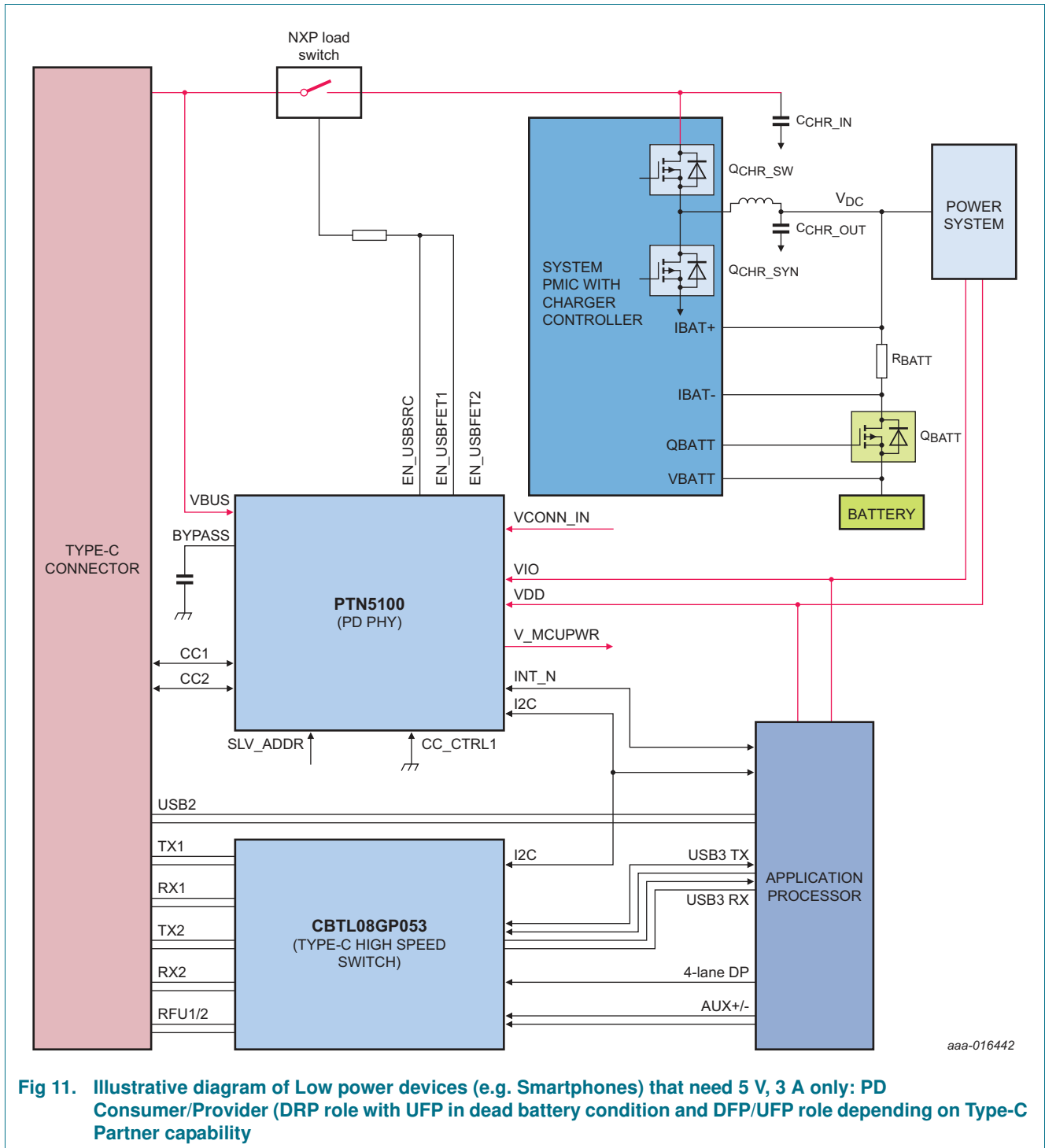

aaa-016442

Fig 11. Illustrative diagram of Low power devices (e.g. Smartphones) that need 5 V, 3 A only: PD Consumer/Provider (DRP role with UFP in dead battery condition and DFP/UFP role depending on Type-C Partner capability)

8.1.3.1 Application description

In this illustration, PTN5100 is behind Type-C receptacle and it is configured to act as a PD consumer/ Provider. It is important to note that there is no dedicated policy controller MCU associated with the PD functionality as this application can operate with 5V, 3A only. Under normal battery/powered condition, PTN5100 is configured as DFP, DRP or UFP based on register configuration setting and it performs cable/plug connect and disconnect detection, orientation detection. However, on dead battery condition, it defaults to UFP role. The power path FET control may or may not be used in the application depending on the capabilities of System PMIC.

This application is expected to

- Receive VBUS 5 V @ 3 A
- Provides VBUS 5 V @ 3 A
- Sourcing VCONN power is dependent on the Type-C role taken

PTN5100 operates autonomously but it is possible for the system processor to control it via I2C interface. Though there may not be a need to negotiate higher voltage/current, the platform may still need to support Alternate modes and VDMs. The Application Processor is used to handle those capabilities.

8.1.4 Type-C cable adapters with PTN5100

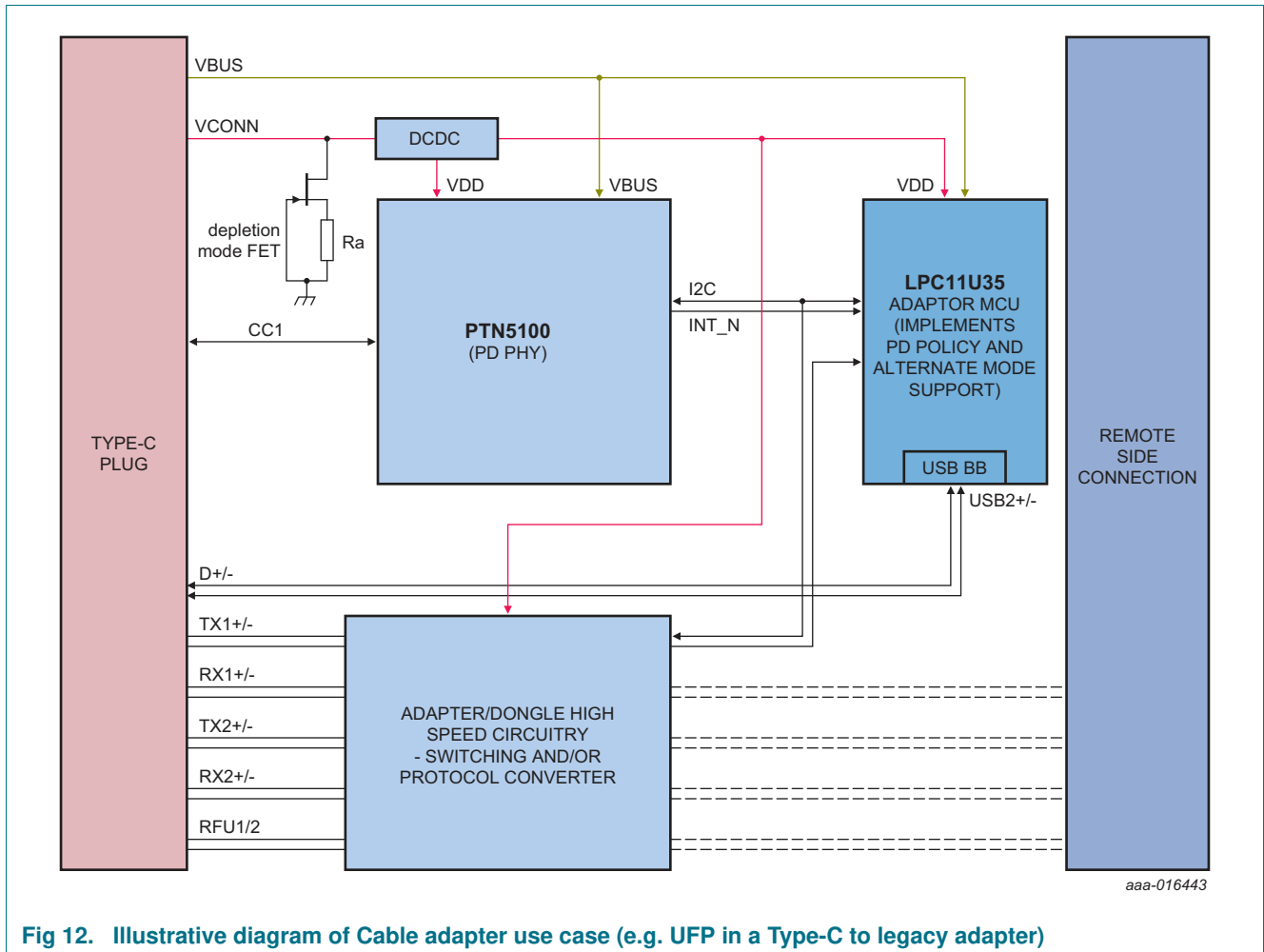

Fig 12. Illustrative diagram of Cable adapter use case (e.g. UFP in a Type-C to legacy adapter)

8.1.4.1 Application description

In this illustration, PTN5100 is inside Type-C cable adapter operating in UFP role. Some example use cases are Type-C to DP adapter, Type-C to VGA adapter, Type-C to Thunderbolt adapter etc. PTN5100 serves as PD PHY layer device for a Cable adapter management MCU or dedicated PD MCU wherein PD policy management, Alternate mode and VDM support are handled. The USB Billboard device is assumed to be implemented as part of adapter management MCU.

The cable adapter implementation operates on VCONN supply. Discrete depletion mode FET has to be used in the application for 'Ra' indication on CC pin.

8.1.5 USB PD Consumer/Provider with Type-C receptacle

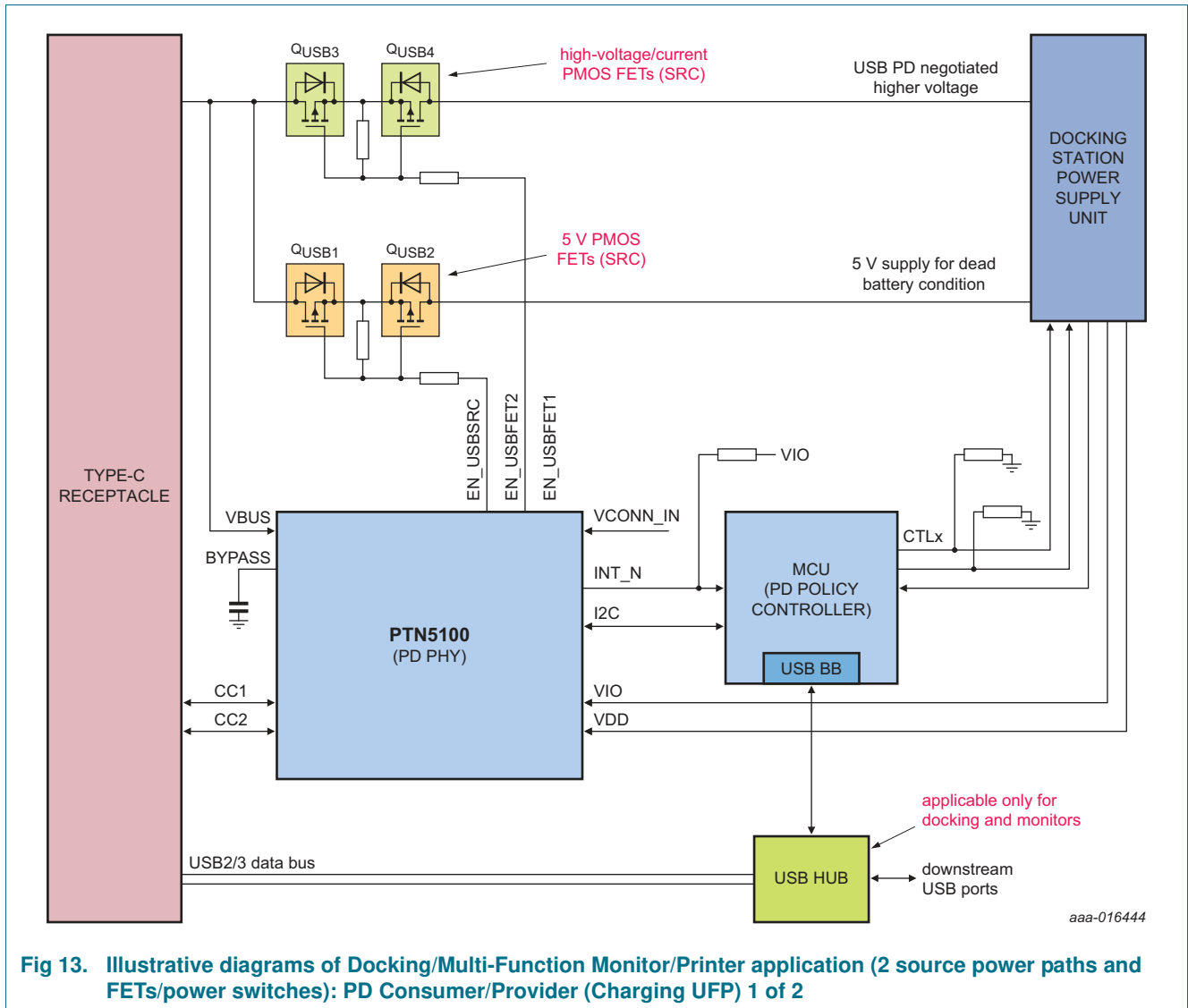

Fig 13. Illustrative diagrams of Docking/Multi-Function Monitor/Printer application (2 source power paths and FETs/power switches): PD Consumer/Provider (Charging UFP) 1 of 2

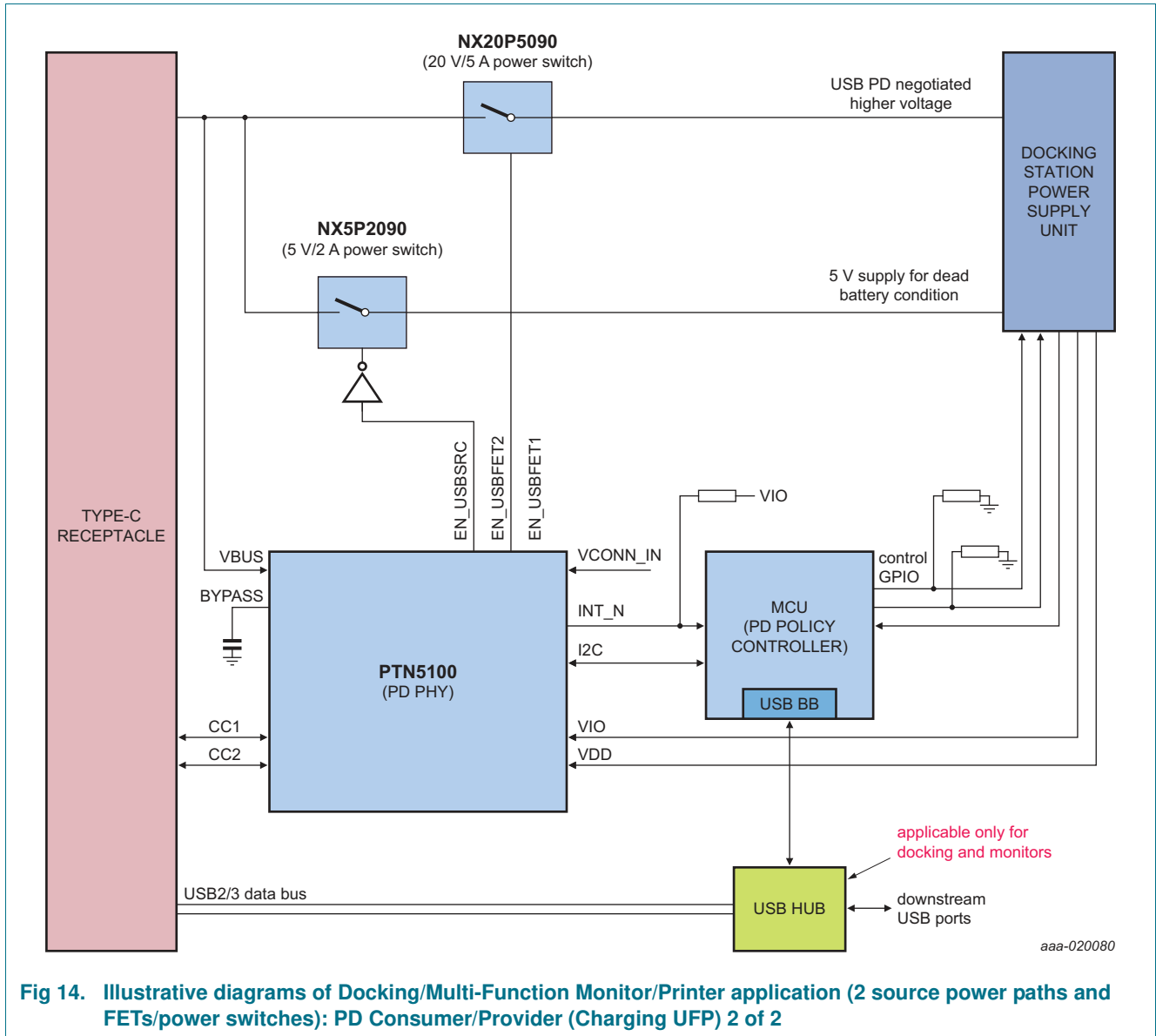

Fig 14. Illustrative diagrams of Docking/Multi-Function Monitor/Printer application (2 source power paths and FETs/power switches): PD Consumer/Provider (Charging UFP) 2 of 2

8.1.5.1 Application description

The example applications are Multi-function monitor, Dock or Printer. PTN5100 is configured for Charging UFP role. The policy controller MCU would probe PTN5100 to make sure there is no dead battery device connected at the other end. If a pull-down 'Rd' is detected at the remote cable end, this platform supplies VBUS 5V. Once the remote end system is capable of performing power role swap, the roles would be reversed.

This application is expected to:

- Receive VBUS 5 V (or provide power during Dead battery operation - VBUS 5 V)
- Provides VBUS PD power

The PD software running on the MCU controls the power FETs/switches to determine VBUS 5 V and USB PD power delivery (Orange colored power FETs/switch on VBUS).

8.1.6 USB PD Consumer with Type-C receptacle example

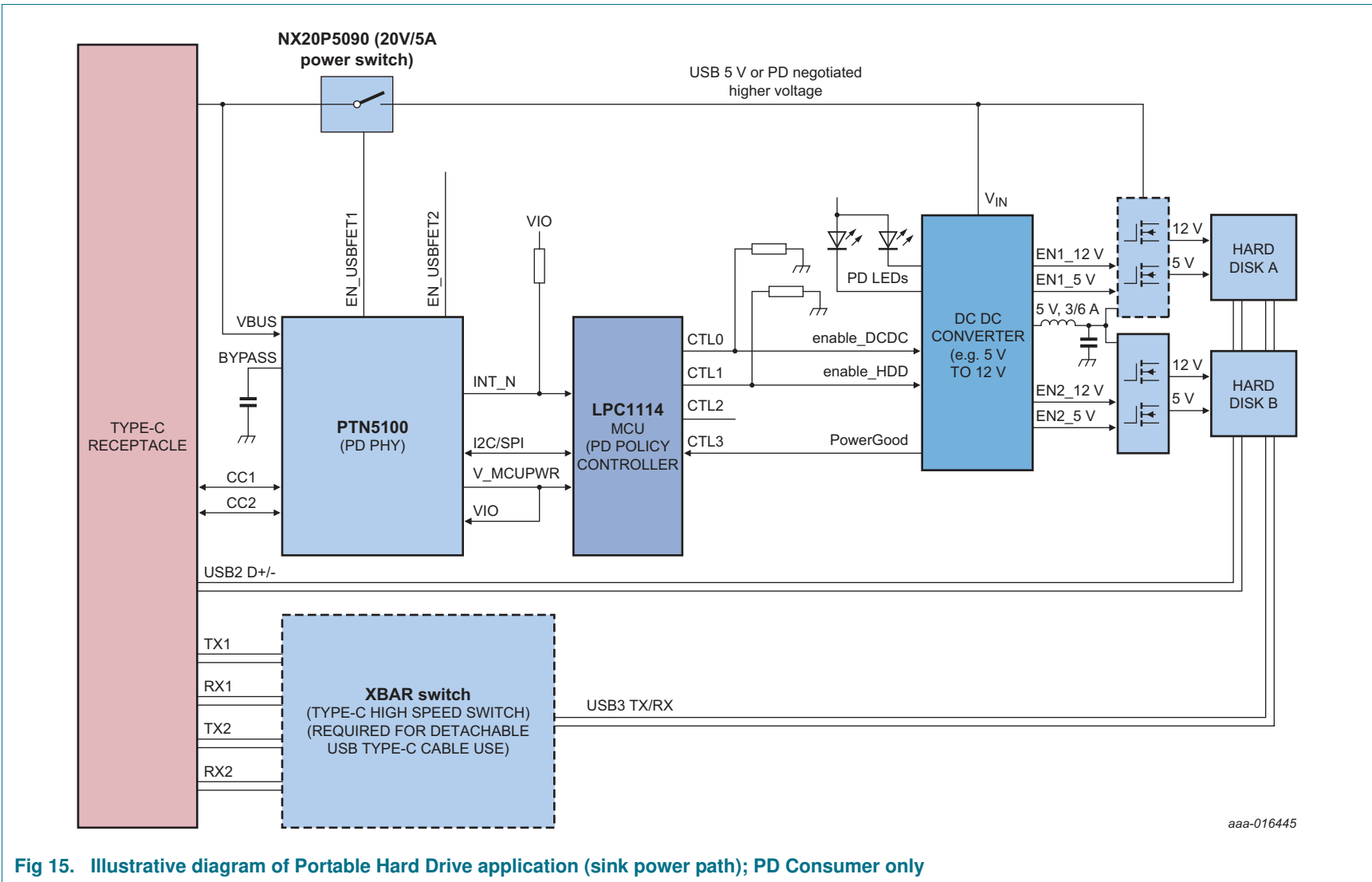

aaa-016445

Fig 15. Illustrative diagram of Portable Hard Drive application (sink power path); PD Consumer only

8.1.6.1 Application description

In a USB PD based hard drive application, PTN5100 + Policy controller MCU operates autonomously. At POR, PTN5100 presents UFP role and starts to receive VBUS 5 V. Then based on configured power profile, PD negotiation and contracting is performed. The MCU interfaces with Hard drive electronics and delivers power after handshake. The MCU's GPIO pins can be reused to handshake with DCDC converter and the handshake mechanism is OEM platform dependent.

This application is expected to:

- Receive VBUS 5 V, USB PD power

9. Limiting values

Table 6. Limiting values

In accordance with the Absolute Maximum Rating System (IEC 60134).

Symbol	Parameter	Conditions	Min	Max	Unit
V _{DD}	supply voltage		-0.5	+4.6	V
V _{IO}	IO voltage		-0.5	+4.6	V
VBUS	USB VBUS voltage		-0.5	+28	V
V _I	Input voltage	voltage at the pin			
		CC_CTRL1, CC_ORIENT, DBGACC_FOUND	-0.5	+4.6	V
		CC1, CC2	-0.5	+6.0	V
		EN_USBSRC, EN_USBFET1, EN_USBFET2	-0.5	+28	V
		BYPASS	-0.5	+2.5	V
		VCONN_IN	-0.5	+6.0	V
		INT_N	-0.5	+4.6	V
		SLV_ADDR	-0.5	+4.6	V
		SPI_CLK_I2C_SCL, SPI_MOSI_SDA, SPI_MISO, SPI_CS	-0.5	+4.6	V
T _{stg}	Storage temperature		-65	+150	°C
V _{ESD}	electrostatic discharge voltage	HBM: VBUS, CC1, CC2 [1][2]	8000	-	V
		HBM for internal pins: [2] CC_CTRL1, CC_ORIENT, DBGACC_FOUND, BYPASS, VCONN_IN, VDD, VIO, INT_N, SLV_ADDR, SPI, EN_USBFET1, EN_USBFET2 and EN_USBSRC signals	2000	-	V
		CDM [3]	1000	-	V

[1] All voltage values, except differential voltages, are with respect to network ground terminal.

[2] Human Body Model: ANSI/ESDA/JEDEC JDS-001-2012 (Revision of ANSI/ESDA/JEDEC JS-001-2011), ESDA/JEDEC Joint standard for ESD sensitivity testing, Human Body Model - Component level; Electrostatic Discharge Association, Rome, NY, USA; JEDEC Solid State Technology Association, Arlington, VA, USA.

[3] Charged Device Model: JESD22-C101E December 2009 (Revision of JESD22-C101D, October 2008), standard for ESD sensitivity testing, Charged Device Model - Component level; JEDEC Solid State Technology Association, Arlington, VA, USA.

10. Recommended operating conditions

Table 7. Operating conditions

Symbol	Parameter	Conditions	Specification guaranteed by	Min	Typ	Max	Unit
VDD	System supply voltage		ATE	3.0	-	3.6	V
VIO	System IO supply voltage	when 3.3 V supply is used	ATE	3.0	-	3.6	V
		when 1.8 V supply is used	ATE	1.7	-	1.9	V
VBUS	USB VBUS voltage		ATE or bench	3.7	-	25	V
V _I	input voltage on the pin		ATE		-		
		CC_CTRL1, CC_ORIENT, DBGACC_FOUND	ATE	-0.3	-	+3.6	V
		CC1, CC2	ATE	-0.3	-	+5.5	V
		EN_USBSRC, EN_USBFET1, EN_USBFET2	ATE	-0.3	-	+25	V
		VCONN_IN	ATE	-0.3	-	+5.5	V
		INT_N	ATE	-0.3	-	+3.6	V
		SLV_ADDR	ATE	-0.3	-	+3.6	V
T _{amb}	Ambient Operating temperature			-20	-	+85	°C

11. Characteristics

11.1 Device characteristics

Table 8. Device characteristics

Applicable across operating temperature and power supply ranges as per [Section 10](#) (unless otherwise noted). Typical values are specified at 27 °C (unless otherwise noted).

Symbol	Parameter	Conditions	Min	Typ	Max	Unit
T _{FET_EN}	Time duration between I2C write/ACK and FET enable asserted	Applicable to all FET enable pins	-	-	10	µs
T _{FET_DIS}	Time duration between I2C write/ACK and FET enable de-asserted	Applicable to all FET enable pins	-	-	10	µs
I _{DD,Active}	Active mode operating current	UFP role; attached condition; V _{DD} = 3.3 V	-	200	-	µA
		DFP role; attached condition; V _{DD} = 3.3 V	-	300	-	µA
		SPI interface is active	-	3	-	µA
		PD mode is functional; does not include power delivered on V _{MCUPWR} pin; V _{DD} = 3.3 V	-	3	-	mA
	Additional current consumed on VDD	VCONN switch is enabled without FCP and RCP; V _{DD} = 3.3 V	-	175	250	µA
		VCONN switch is enabled with FCP and RCP; V _{DD} = 3.3 V	-	250	340	µA
I _{DD(idle)}	Idle mode current on VDD	UFP role; Unattached condition	-	50	-	µA
		DFP role; Unattached condition (R _p at standard current level)	-	70	-	µA
		DRP mode; Unattached condition	-	100	-	µA
I _{VIO(idle)}	Idle mode supply current (VIO)		-	-	10	µA
I _{bckdrv}	Backdrive current	Backdrive current on VDD pin when that pin is at 0 V				
		CC1, CC2 = 5V	-10	-	10	µA
I _{LIH,EN}	HIGH-level input leakage current	V _I =3.3V, applies to CC1, CC2	-	-	20	µA
I _{LIL,EN}	LOW-level input leakage current	V _I =GND, Applies to CC1, CC2	-20	-	0	µA

11.2 USB PD and Type-C characteristics

Table 9. USB PD and Type-C AC/DC characteristics

Applicable across operating temperature and power supply ranges as per [Section 10](#) (unless otherwise noted). Typical values are specified at 27 °C (unless otherwise noted).

Symbol	Parameter	Conditions	Min	Typ	Max	Unit
USB PD normative specification						
f _{Bitrate}	Bit rate		270	300	330	Kbps
t _{UnitInterval}	unit interval		3.03	-	3.7	μs
p _{BitRate}	Maximum difference between the bit-rate during the payload and the reference bit-rate (The reference bit rate is the average bit rate of the last 32 bits of the preamble)	At the transmitter	-	-	0.25	%
t _{InterFrameGap}	Time from the end of last bit of a Frame until the start of the first bit of the next Preamble.		25	-	-	μs
t _{StartDrive}	Time before the start of the first bit of the Preamble when the transmitter shall start driving the line.		-1	-	1	μs
USB PD transmitter normative specification						
t _{EndDriveBMC}	Time to cease driving the line after the end of the last bit of the Frame.	Min value is limited by t _{HoldLowBMC}	-	-	23	μs
t _{Fall}	Fall time	10 % and 90 % amplitude points, minimum is under unloaded condition	300	-	-	ns
t _{HoldLowBMC}	Time to cease driving the line after the final high-to-low transition	Max value is limited by t _{EndDriveBMC}	1	-	-	us
t _{Rise}	Rise time	10 % and 90 % amplitude points, minimum is under unloaded condition	300	-	-	ns
V _{Swing}	Voltage swing		1.05	1.125	1.2	V
Z _{Driver}	Transmitter output impedance	Source output impedance at the Nyquist frequency of [USB2.0] low speed (750 kHz) while the source is driving the CC line.	33	-	75	Ω
USB PD receiver normative specification						
C _{Receiver}	CC Receiver capacitance	The CC pin (DFP or UFP) capacitance when not transmitting on the line	200	-	600	pF
n _{TransitionCount}	Transitions for signal detect		3	-	-	
t _{RxFilter}	Time constant of Rx bandwidth limiting filter		100	-	-	ns
t _{TransitionWindow}	Time window for detecting non-idle		12	-	20	μs
Z _{BmcRx}	Receiver Input Impedance		10	-	-	MΩ

Table 9. USB PD and Type-C AC/DC characteristics ...continued

Applicable across operating temperature and power supply ranges as per [Section 10](#) (unless otherwise noted). Typical values are specified at 27 °C (unless otherwise noted).

Symbol	Parameter	Conditions	Min	Typ	Max	Unit
Type-C specification						
I _{pullup}	Current source for DFP pullup indication	Default current	64	80	96	μA
		1.5 A	166	180	194	μA
		3 A	314	330	346	μA
R _{pulldn}	Pulldown termination on UFP	After on-board calibration is completed	4.6	5.1	5.6	kΩ
Z _{OPEN}	UFP CC termination	Applies to self-powered UFP to remain undetectable by DFP	126	-	-	kΩ
V _{CLAMPH}	High current mode clamp voltage	UFP mode; VDD = 0, VBUS = 0	0.85	-	2.18	V
V _{CLAMPM}	Medium current mode clamp voltage	UFP mode; VDD = 0, VBUS = 0	0.45	-	1.25	V
V _{CLAMPD}	Default current mode clamp voltage	UFP mode; VDD = 0, VBUS = 0	0.25	-	1.25	V
V _{TUM}	Medium current mode detection threshold	UFP mode	1.16	1.23	1.31	V
V _{TUS}	Standard current mode detection threshold	UFP mode	0.61	0.66	0.70	V
V _{TURa}	Powered Accessory (Ra) mode detection threshold	UFP mode	0.15	0.2	0.25	V
V _{TDH,Ra}	High current mode Ra detection threshold	DFP mode	0.75	0.8	0.85	V
V _{TD,Rd}	Rd detection threshold	DFP mode	2.45	2.6	2.75	V
V _{TDM,Ra}	Medium current mode Ra detection threshold	DFP mode	0.35	0.4	0.45	V
V _{TDS,Ra}	Standard current mode Ra detection threshold	DFP mode	0.15	0.2	0.25	V

11.3 VCONN switch characteristics

Table 10. VCONN switch characteristics

Applicable across operating temperature and power supply ranges as per [Section 10](#) (unless otherwise noted). Typical values are specified at 27 °C (unless otherwise noted).

Symbol	Parameter	Conditions	Min	Typ	Max	Unit
V _{VCONN_IN}	VCONN_IN voltage		2.7	-	5.5	V
I _{VCONN_IN}	DC Current		-	-	1	A
R _{ON}	ON resistance		-	150	240	mΩ
C _{ON}	ON capacitance		-	450	-	pF
C _{OFF}	OFF Capacitance		-	250	-	pF
I _{inrush}	Inrush current	When VCONN switch is enabled; corresponding CCx pin voltage is zero; CC capacitance = 10 μF	-	-	150	mA

Table 10. VCONN switch characteristics ...continued

Applicable across operating temperature and power supply ranges as per [Section 10](#) (unless otherwise noted). Typical values are specified at 27 °C (unless otherwise noted).

Symbol	Parameter	Conditions	Min	Typ	Max	Unit
I _{FCP}	Forward Current Protection Limit	@ threshold of 250 mA	125	250	350	mA
		@ threshold of 500 mA	350	500	700	mA
		@ threshold of 1 A	700	1000	1300	mA
I _{RCP}	Reverse Current Protection limit		-	60	110	mA
T _{dis}	VCONN Switch disable time due to FCP or RCP fault		-	-	300	µs

11.4 Power AC/DC characteristics

Table 11. Power AC/DC characteristics

Applicable across operating temperature and power supply ranges as per [Section 10](#) (unless otherwise noted). Typical values are specified at 27 °C (unless otherwise noted).^[1]

Symbol	Parameter	Conditions	Min	Typ	Max	Unit
V _{MCUPWR}	DC Voltage on V_MCUPWR pin	Applies to both VBUS and VDD	2.5	-	3.6	V
I _{MCUPWR}	DC Current delivered out of V_MCUPWR pin	Applies to both VBUS and VDD; 2.2 µF ±10 % De-coupling capacitor on V_MCUPWR pin	-	-	30	mA
I _{inrush}	Inrush current	2.2 µF capacitors on BYPASS and V_MCUPWR pins, these pins are at 0 V	-	150	-	mA
V _{OUT_load}	V_MCUPWR voltage	VBUS @ 3.7 V, load current 30 mA	2.5	-	3.6	V
V _{Line_reg}	Line voltage regulation	VBUS sweep 3.7 V to 25 V; load current 30 mA	-	-	200	mV
V _{Load_reg}	Load voltage regulation	VBUS @ 3.7 V; load current sweep 0 mA to 30 mA	-	-	50	mV
V _{Load_step}	Load voltage variation under load step	VBUS @ 3.7 V; load current step from 0 to 30 mA over 30 µs interval	-	-	150	mV
PSRR	Power supply rejection ratio	VBUS @ 3.7 V to 25 V				
		DC		70		dB
		F = 100 kHz		50		dB
		F = 1 MHz		30		dB

[1] For all the specification measurements, supply decoupling capacitor 2.2 µA ±10 % is considered to be present on V_MCUPWR pin. Also, the capacitor is charged up to V_MCUPWR voltage unless otherwise specified.

11.5 I2C characteristics

Table 12. I2C characteristics

Applicable across operating temperature and power supply ranges as per [Section 10](#) (unless otherwise noted). Typical values are specified at 27 °C (unless otherwise noted).^[1]

Symbol	Parameter	Conditions	Min	Typ	Max	Unit
F _{I2C}	I2C clock frequency		0	-	1000	kHz
V _{IH}	HIGH-level Input voltage		0.7 × VDDIO	-	-	V
V _{IL}	LOW-level Input voltage		-	-	0.3 × VDDIO	V
V _{hys}	Hysteresis of Schmitt trigger inputs	VDDIO > 2 V	0.05× VDDIO	-	-	V
		VDDIO < 2 V	0.1 × VDDIO	-	-	V
V _{OL}	LOW-level output voltage at 3mA sink current	VDDIO > 2 V	0	-	0.4	V
		VDDIO < 2 V	0	-	0.2× VDDIO	V
I _{OL}	LOW-level output current	V _{OL} = 0.4 V; Standard and Fast modes	3	-	-	mA
		V _{OL} = 0.4 V; Fast mode plus	20	-	-	mA
		V _{OL} = 0.6 V; Fast mode	6	-	-	mA
I _{IL}	LOW-level input current	Pin voltage - 0.1×VDDIO to 0.9×VIO, max	-10	-	10	μA
C _I	Capacitance of IO pin		-	-	10	pF
t _{HD,STA}	Hold time (repeated) START condition	Fast mode plus; After this period, the first clock pulse is generated	0.26	-	-	μs
t _{LOW}	LOW period of I2C clock	Fast mode plus	0.5	-	-	μs
t _{HIGH}	HIGH period of I2C clock	Fast mode plus	0.26	-	-	μs
t _{SU,STA}	Setup time (repeated) START condition	Fast mode plus	0.26	-	-	μs
t _{HD,DAT}	Data Hold time	Fast mode plus	0	-	-	μs
t _{SU,DAT}	Data Setup time	Fast mode plus	50	-	-	ns
t _r	Rise time of I2C_SCL and I2C_SDA signals	Fast mode plus	-	-	120	ns
t _f	Fall time of I2C_SCL and I2C_SDA signals	Fast mode plus	-	-	120	ns
t _{SU,STO}	Setup time for STOP condition	Fast mode plus	0.26	-	-	μs
t _{BUF}	Bus free time between STOP and START condition	Fast mode plus	0.5	-	-	μs

Table 12. I2C characteristics ...continued

Applicable across operating temperature and power supply ranges as per [Section 10](#) (unless otherwise noted). Typical values are specified at 27 °C (unless otherwise noted).^[1]

Symbol	Parameter	Conditions	Min	Typ	Max	Unit
$t_{VD;DAT}$	Data valid time	Fast mode plus	0.45	-	-	μ s
$t_{VD;ACK}$	Data valid acknowledge time	Fast mode plus	0.45	-	-	μ s
t_{SP}	Pulse width of spikes that must be suppressed by input filter		-	-	50	ns

[1] V_{DDIO} is I2C bus pull up voltage.

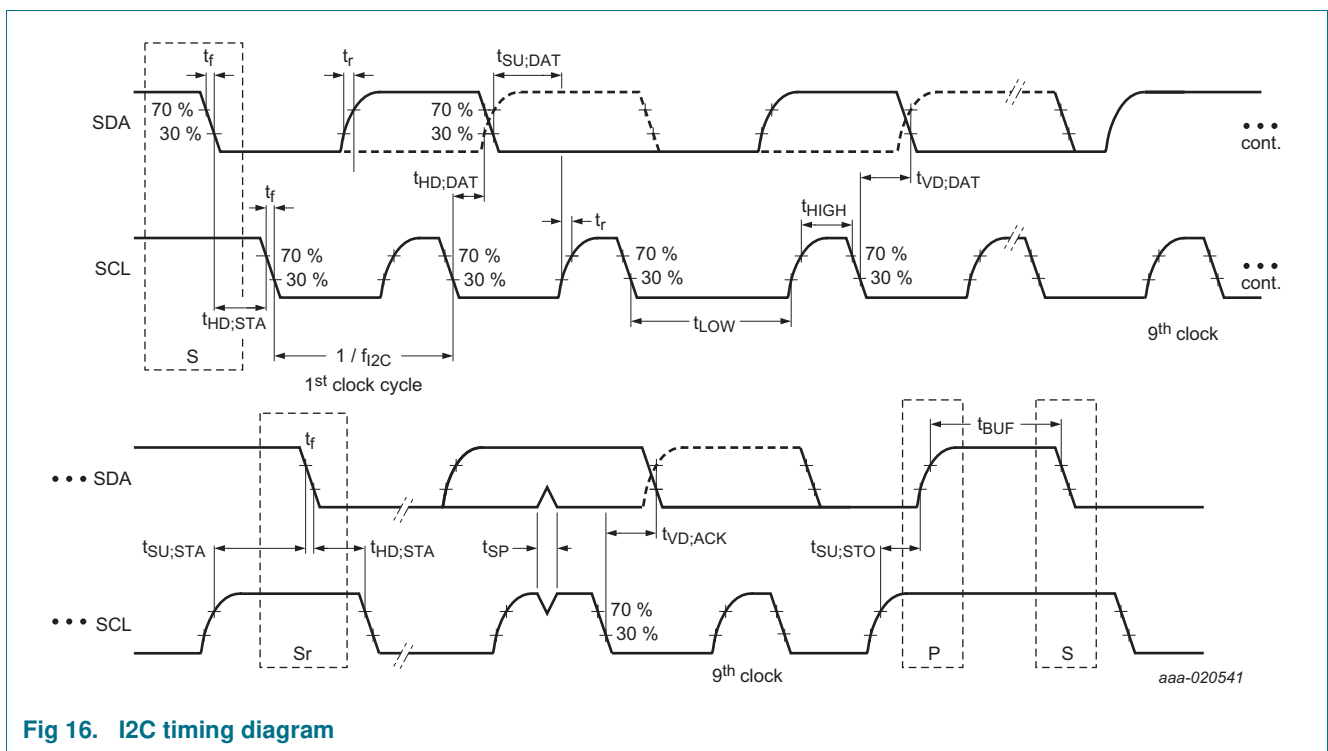

Fig 16. I2C timing diagram

11.6 SPI characteristics

Table 13. SPI interface: AC/DC characteristics

Applicable across operating temperature and power supply ranges as per [Section 10](#) (unless otherwise noted). Typical values are specified at 27 °C (unless otherwise noted).

Symbol	Parameter	Conditions	Min	Typ	Max	Unit
f _{SPI}	SPI clock frequency (SPI_CLK)	Applies to both TX and RX	-	-	20	MHz
t _{SPI;HI}	SPI clock HIGH time		20	-	-	ns
t _{SPI;LO}	SPI clock LOW time		20	-	-	ns
t _{SPI;rise}	SPI clock (LOW to HIGH) rise time		0.1	-	-	V/ns
t _{SPI;fall}	SPI clock (HIGH to LOW) fall time		0.1	-	-	V/ns
t _{SPI;CSNS}	SPI_CS Not Setup time	Relative to SPI clock pin	0	-	-	ns
t _{SPI;CSNH}	SPI_CS Not Hold time	Relative to SPI clock pin	0	-	-	ns
t _{SPI;DINS}	Data In Setup time	Applies to SPI_MOSI_I2C_SDA; relative to SPI clock	5	-	-	ns
t _{SPI;DINH}	Data In Hold time	Applies to SPI_MOSI_I2C_SDA; relative to SPI clock	5	-	-	ns
t _{SPI;DONS}	SPI clock edge to Valid Data Out	Applies to SPI_MISO	-	-	7	ns
t _{SPI;DONH}	SPI clock edge to Data Out Hold time	Applies to SPI_MISO	0	-	-	ns
C _{L;SPI}	Maximum IO capacitance supported	SPI_CLK_I2C_SCL, SPI_MOSI_I2C_SDA	-	-	10	pF
C _{IN;SPI}	Maximum IO capacitance	SPI_MISO, SPI_CS	-	-	10	pF
V _{IH;SPI}	HIGH-level input voltage	SPI_MISO	0.7 × V _{MCUPWR}	-	-	V
V _{IL;SPI}	LOW-level input voltage	SPI_MISO	-	-	0.3 × V _{MCUPWR}	V
V _{OL;SPI}	LOW-level output voltage	SPI_CLK_I2C_SCL, SPI_CS, SPI_MOSI_I2C_SDA IOL = 4 mA	-	-	0.5	V
V _{OH;SPI}	HIGH-level output voltage	SPI_CLK_I2C_SCL, SPI_CS, SPI_MOSI_I2C_SDA IOH = -4 mA	V _{MCUPWR} - 0.5	-	-	V
I _{LIH;EN}	HIGH-level input leakage current	VI = 3.3 V	-1	-	1	μA
I _{LIL;EN}	LOW-level input leakage current	VI = GND	-1	-	1	μA

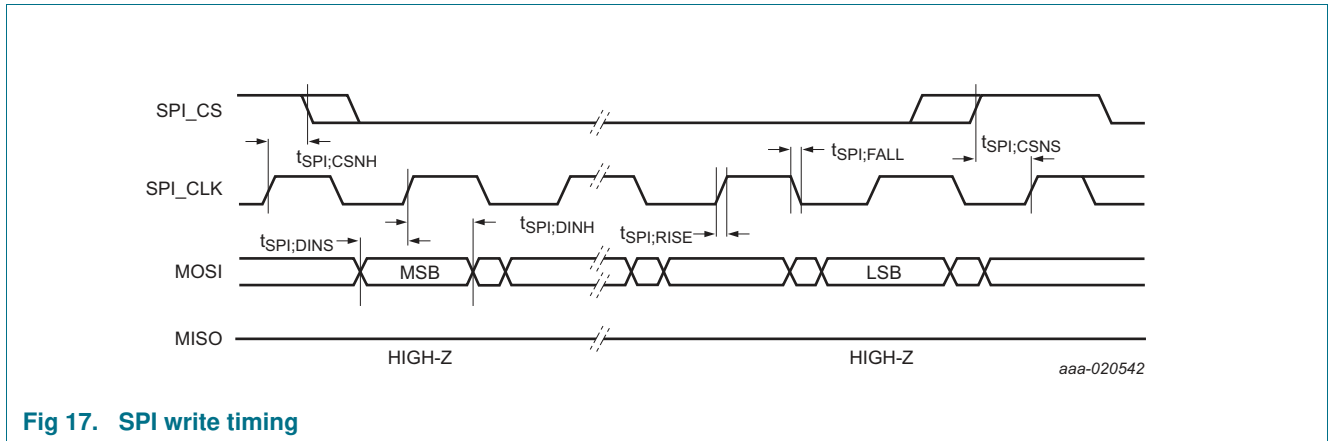

Fig 17. SPI write timing

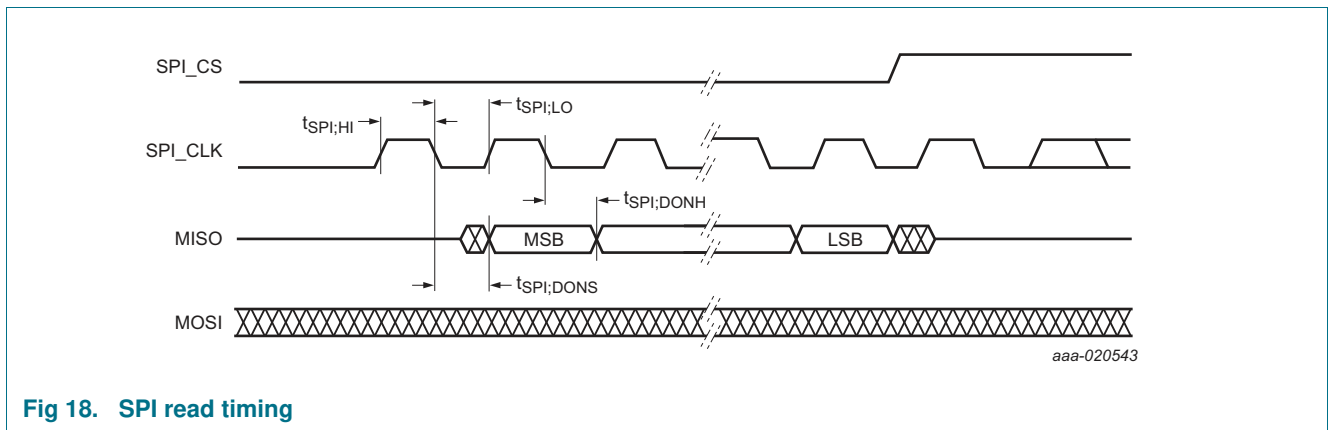

Fig 18. SPI read timing

11.7 CONTROL IO characteristics

Table 14. Control I/O characteristics

Applicable across operating temperature and power supply ranges as per [Section 10](#) (unless otherwise noted). Typical values are specified at 27 °C (unless otherwise noted).

Symbol	Parameter	Conditions	Min	Typ	Max	Unit
System side CMOS output pins (CC_ORIENT, DBGACC_FOUND)						
V_{OH}	HIGH-level Output voltage	$I_{OH} = -4 \text{ mA}$	$V_{IO} - 0.5$	-		V
V_{OL}	LOW-level Output voltage	$I_{OL} = 4 \text{ mA}$	-	-	0.5	V
C_I	Capacitance of IO pin		-	-	20	pF
$I_{LIH,EN}$	HIGH-level input leakage current	$V_I = 3.3 \text{ V}$	-1	-	1	μA
$I_{LIL,EN}$	LOW-level input leakage current	$V_I = \text{GND}$	-1	-	1	μA
System side input pins (CC_CTRL1)						
V_{IL}	LOW-level Input voltage	applies to CC_CTRL1	-	-	0.4	V
		applies to SLV_ADDR	-	-	$0.3 \times V_{DD}$	V

Table 14. Control I/O characteristics ...continued

Applicable across operating temperature and power supply ranges as per [Section 10](#) (unless otherwise noted). Typical values are specified at 27 °C (unless otherwise noted).

Symbol	Parameter	Conditions	Min	Typ	Max	Unit
V _{IH}	HIGH-level input voltage	applies to SLV_ADDR	0.7 × VDD	-	-	V
C _I	Capacitance of IO pin	applies to CC_CTRL1, SLV_ADDR	-	-	20	pF
I _{LIH,EN}	HIGH-level input leakage current	V _I = 3.3 V	-1	-	1	μA
I _{LIL,EN}	LOW-level input leakage current	V _I = GND	-1	-	1	μA
System side open drain interface pins (INT_N); pulled up to VDDIO						
V _{OL}	LOW-level Output voltage	I _{OL} = 4 mA	-	-	0.5	V
C _I	Capacitance of IO pin		-	-	20	pF

Table 14. Control I/O characteristics ...continued

Applicable across operating temperature and power supply ranges as per [Section 10](#) (unless otherwise noted). Typical values are specified at 27 °C (unless otherwise noted).

Symbol	Parameter	Conditions	Min	Typ	Max	Unit
FET enable pins (EN_USBSRC, EN_USBFET1, EN_USBFET2)						
V _{OL,EN}	LOW-level output voltage	I _{OL} = 4 mA	-	-	0.5	V
V _{IH,EN}	HIGH-level input voltage	FET enable pins are in Hi-Z	0.7 × V _{MCUPWR}	-	25	V
I _{LIH,EN}	HIGH-level input leakage current	V _I = 25 V	-1	-	1	μA
I _{LIL,EN}	LOW-level input leakage current	V _I = GND	-1	-	1	μA

[1] VFET_Bias is the bias voltage on the FET enable pins

12. Package outline

HVQFN20: plastic thermal enhanced very thin quad flat package; no leads;
20 terminals; body 4 x 4 x 0.85 mm

SOT917-4

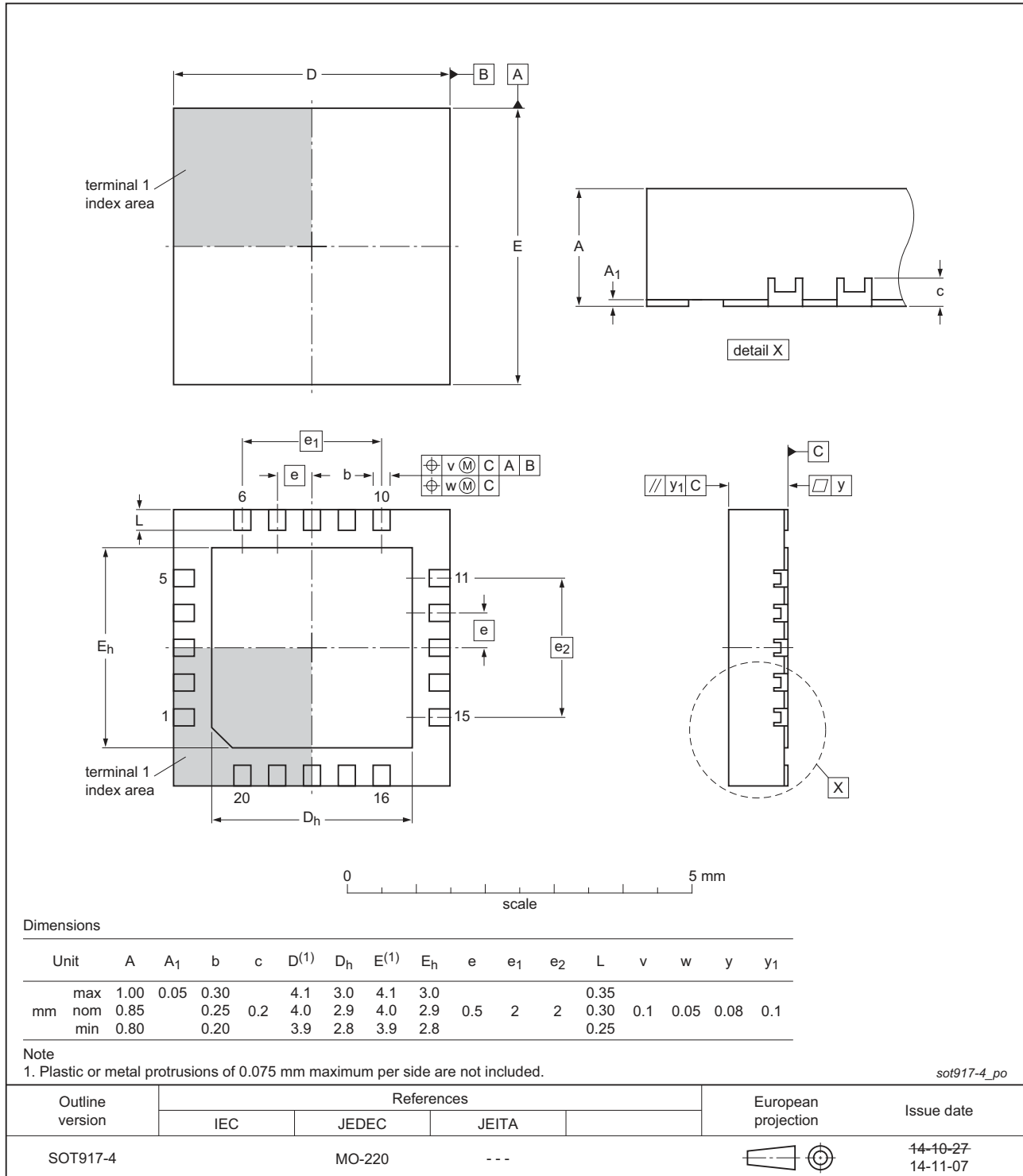

Fig 19. Package outline SOT917-4 (HVQFN20)

13. Packing information

13.1 SOT917-4: HVQFN20; Reel pack, SMD, 13" Q2/T3 standard product orientation; Orderable part number ending ,128 or HP; Ordering code (12NC) ending 128

13.1.1 Packing method

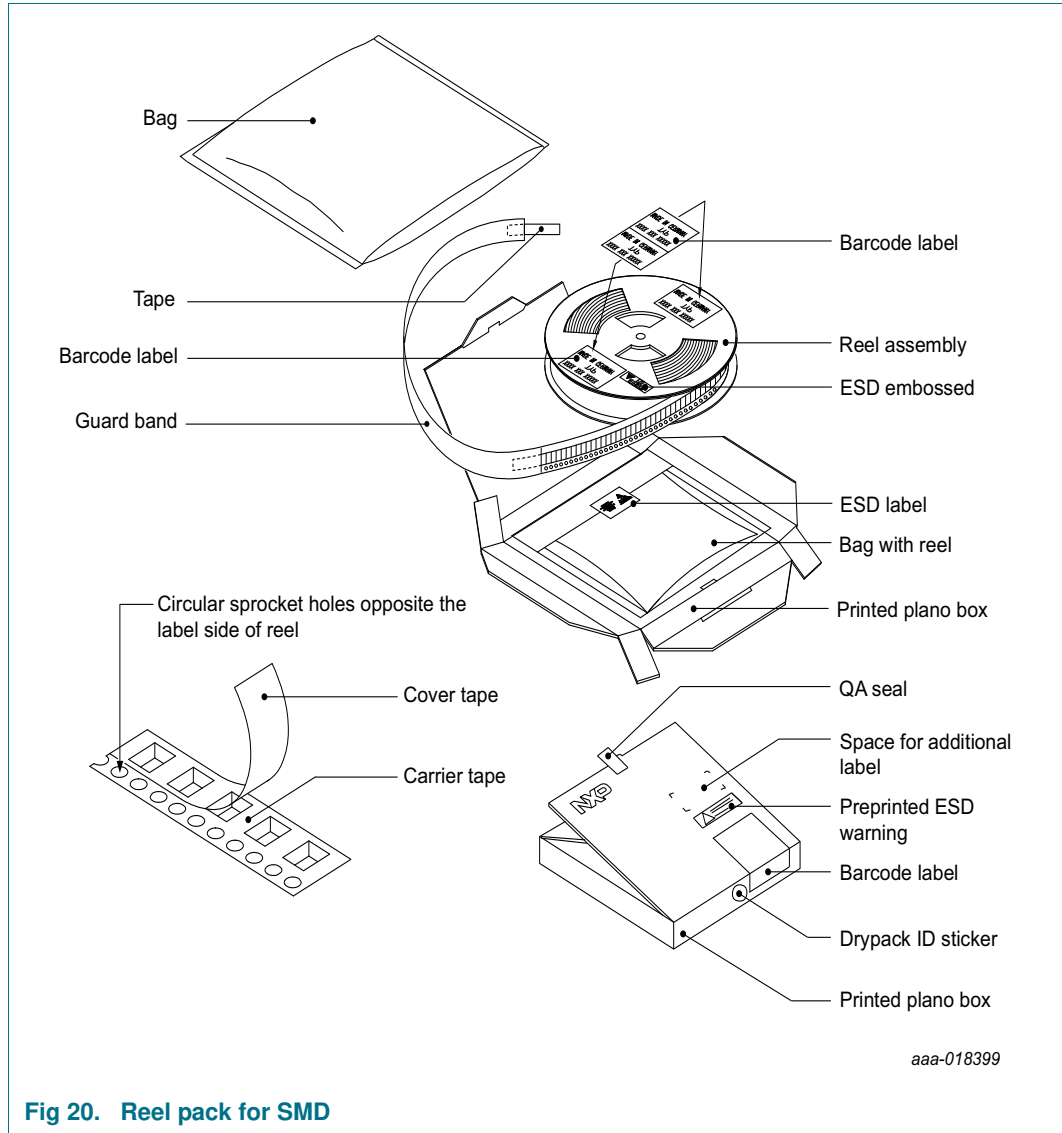

Table 15. Dimensions and quantities

Reel dimensions d × w (mm) [1]	SPQ/PQ (pcs)[2]	Reels per box	Outer box dimensions l × w × h (mm)
330 × 12	6000	1	342 × 338 × 27

[1] d = reel diameter; w = tape width.

[2] Packing quantity dependent on specific product type.

View ordering and availability details at [NXP order portal](#), or contact your local NXP representative.

13.1.2 Product orientation

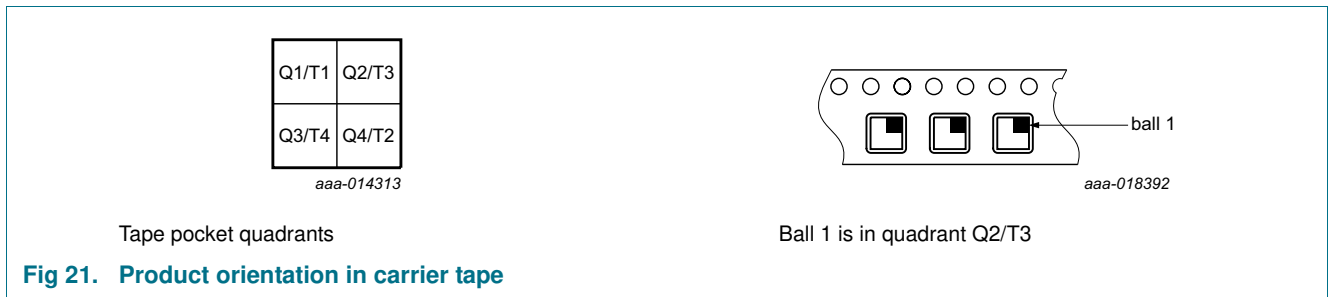

13.1.3 Carrier tape dimensions

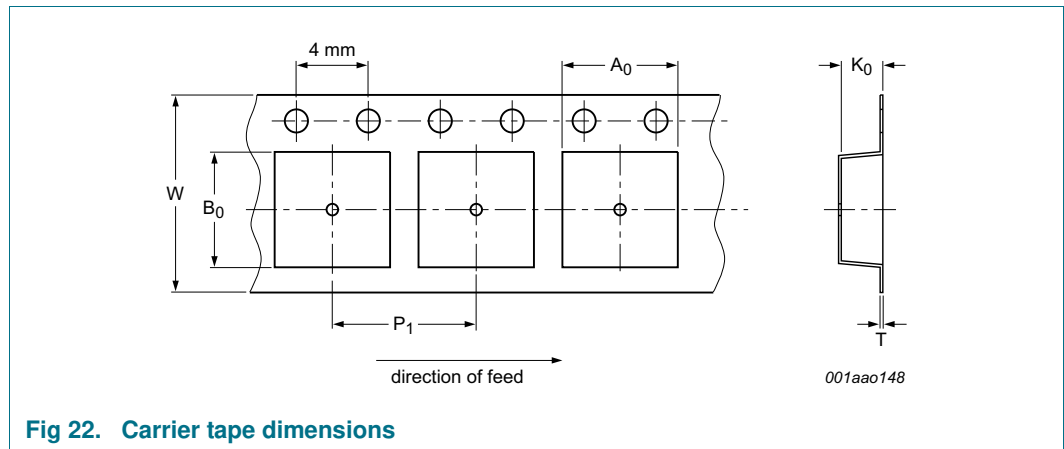

Table 16. Carrier tape dimensions

In accordance with IEC 60286-3.

A ₀ (mm)	B ₀ (mm)	K ₀ (mm)	T (mm)	P ₁ (mm)	W (mm)
4.30 ± 0.10	4.30 ± 0.10	1.10 ± 0.10	0.30 ± 0.05	8.0 ± 0.10	12 ± 0.30

13.1.4 Reel dimensions

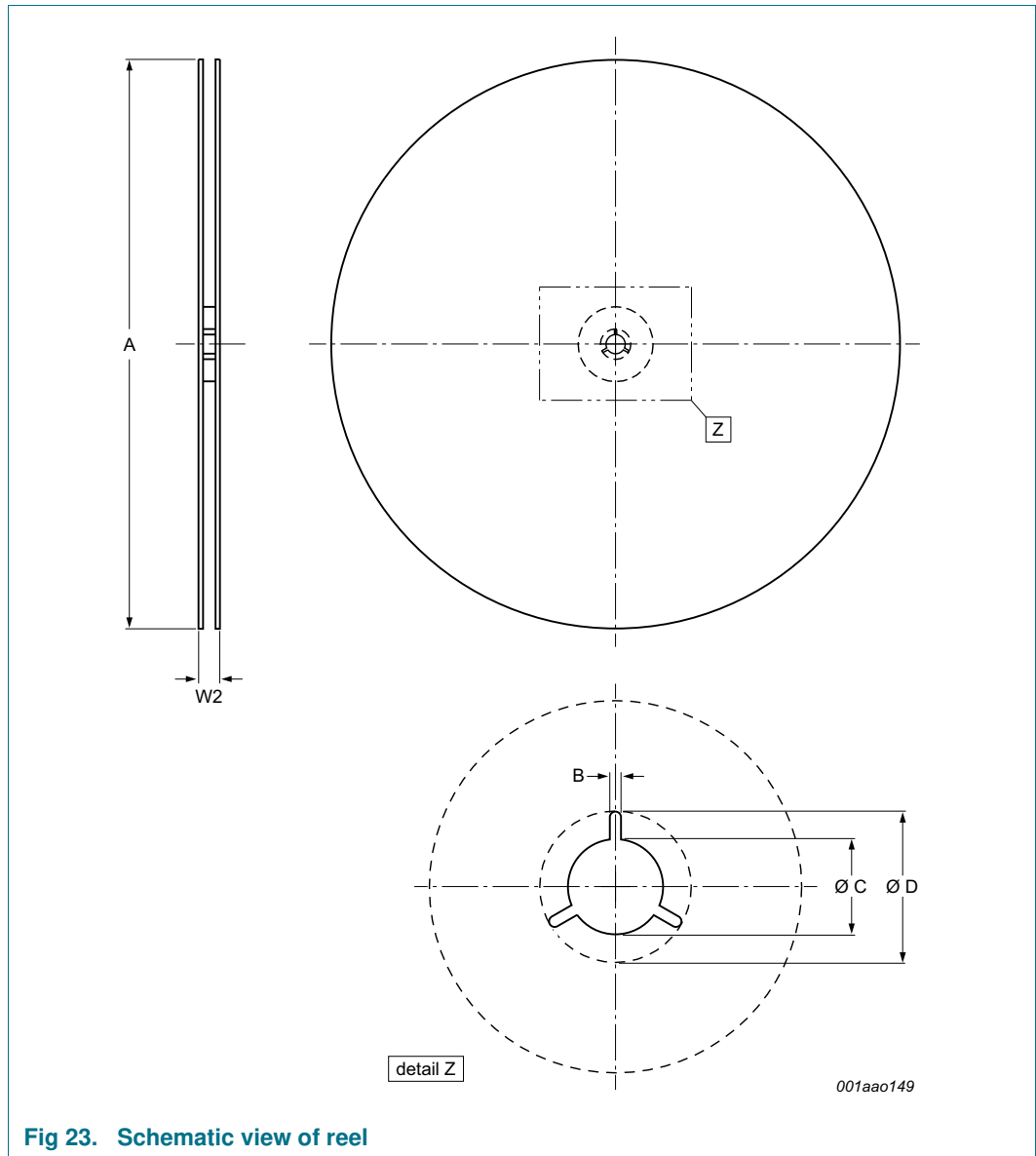

Fig 23. Schematic view of reel

Table 17. Reel dimensions
In accordance with IEC 60286-3.

A [nom] (mm)	W2 [max] (mm)	B [min] (mm)	C [min] (mm)	D [min] (mm)
330	18.4	1.5	12.8	20.2

13.1.5 Barcode label

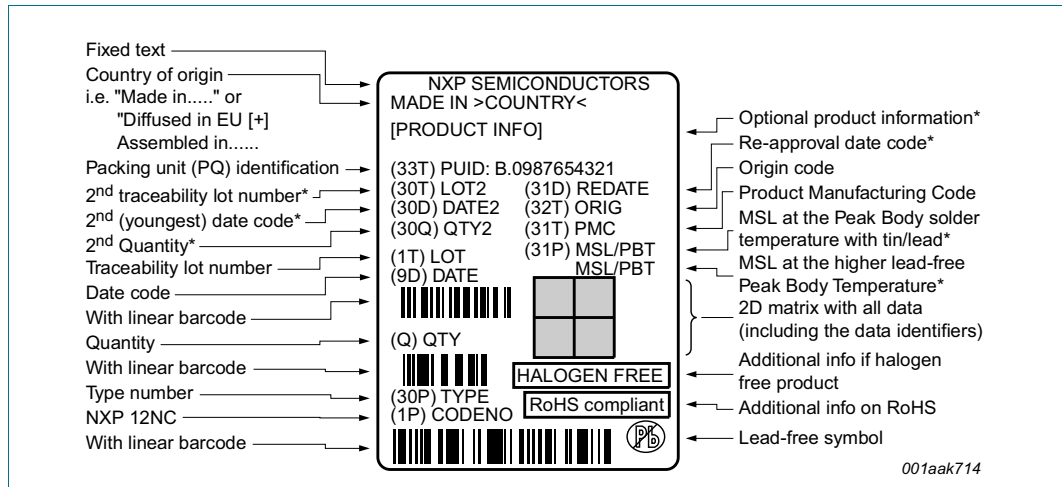

Fig 24. Example of typical box and reel information barcode label

Table 18. Barcode dimensions

Box barcode label l × w (mm)	Reel barcode label l × w (mm)
100 × 75	100 × 75

14. Soldering of SMD packages

This text provides a very brief insight into a complex technology. A more in-depth account of soldering ICs can be found in Application Note *AN10365 "Surface mount reflow soldering description"*.

14.1 Introduction to soldering

Soldering is one of the most common methods through which packages are attached to Printed Circuit Boards (PCBs), to form electrical circuits. The soldered joint provides both the mechanical and the electrical connection. There is no single soldering method that is ideal for all IC packages. Wave soldering is often preferred when through-hole and Surface Mount Devices (SMDs) are mixed on one printed wiring board; however, it is not suitable for fine pitch SMDs. Reflow soldering is ideal for the small pitches and high densities that come with increased miniaturization.

14.2 Wave and reflow soldering

Wave soldering is a joining technology in which the joints are made by solder coming from a standing wave of liquid solder. The wave soldering process is suitable for the following:

- Through-hole components
- Leaded or leadless SMDs, which are glued to the surface of the printed circuit board

Not all SMDs can be wave soldered. Packages with solder balls, and some leadless packages which have solder lands underneath the body, cannot be wave soldered. Also, leaded SMDs with leads having a pitch smaller than ~0.6 mm cannot be wave soldered, due to an increased probability of bridging.

The reflow soldering process involves applying solder paste to a board, followed by component placement and exposure to a temperature profile. Leaded packages, packages with solder balls, and leadless packages are all reflow solderable.

Key characteristics in both wave and reflow soldering are:

- Board specifications, including the board finish, solder masks and vias
- Package footprints, including solder thieves and orientation
- The moisture sensitivity level of the packages
- Package placement
- Inspection and repair
- Lead-free soldering versus SnPb soldering

14.3 Wave soldering

Key characteristics in wave soldering are:

- Process issues, such as application of adhesive and flux, clinching of leads, board transport, the solder wave parameters, and the time during which components are exposed to the wave
- Solder bath specifications, including temperature and impurities

14.4 Reflow soldering

Key characteristics in reflow soldering are:

- Lead-free versus SnPb soldering; note that a lead-free reflow process usually leads to higher minimum peak temperatures (see [Figure 25](#)) than a SnPb process, thus reducing the process window
- Solder paste printing issues including smearing, release, and adjusting the process window for a mix of large and small components on one board
- Reflow temperature profile; this profile includes preheat, reflow (in which the board is heated to the peak temperature) and cooling down. It is imperative that the peak temperature is high enough for the solder to make reliable solder joints (a solder paste characteristic). In addition, the peak temperature must be low enough that the packages and/or boards are not damaged. The peak temperature of the package depends on package thickness and volume and is classified in accordance with [Table 19](#) and [20](#)

Table 19. SnPb eutectic process (from J-STD-020D)

Package thickness (mm)	Package reflow temperature (°C)	
	Volume (mm ³)	
	< 350	≥ 350
< 2.5	235	220
≥ 2.5	220	220

Table 20. Lead-free process (from J-STD-020D)

Package thickness (mm)	Package reflow temperature (°C)		
	Volume (mm ³)		
	< 350	350 to 2000	> 2000
< 1.6	260	260	260
1.6 to 2.5	260	250	245
> 2.5	250	245	245

Moisture sensitivity precautions, as indicated on the packing, must be respected at all times.

Studies have shown that small packages reach higher temperatures during reflow soldering, see [Figure 25](#).

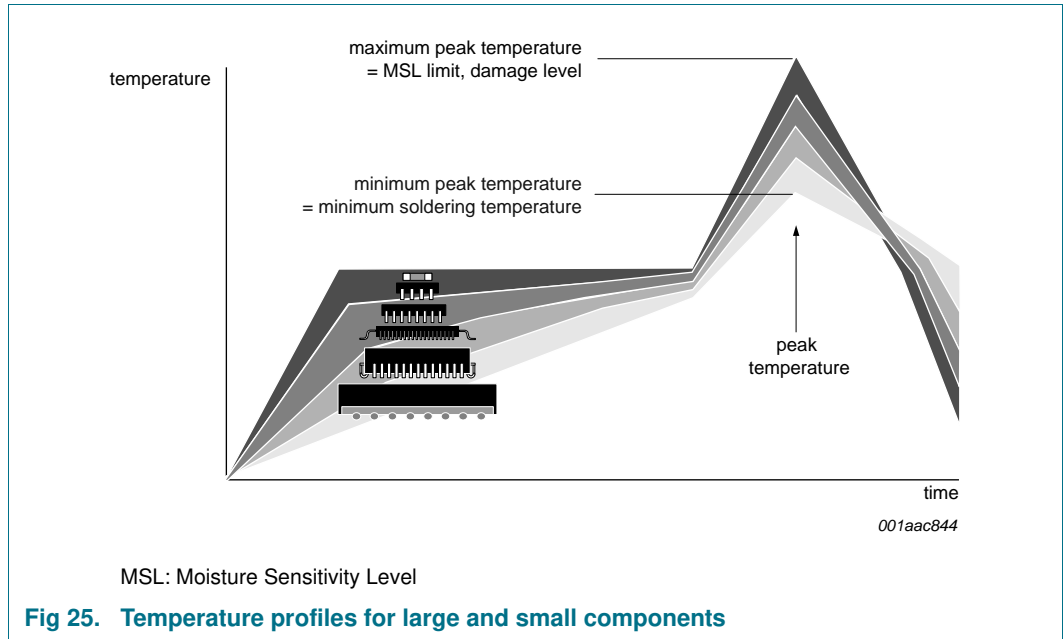

For further information on temperature profiles, refer to Application Note *AN10365* “Surface mount reflow soldering description”.

15. Soldering: PCB footprints

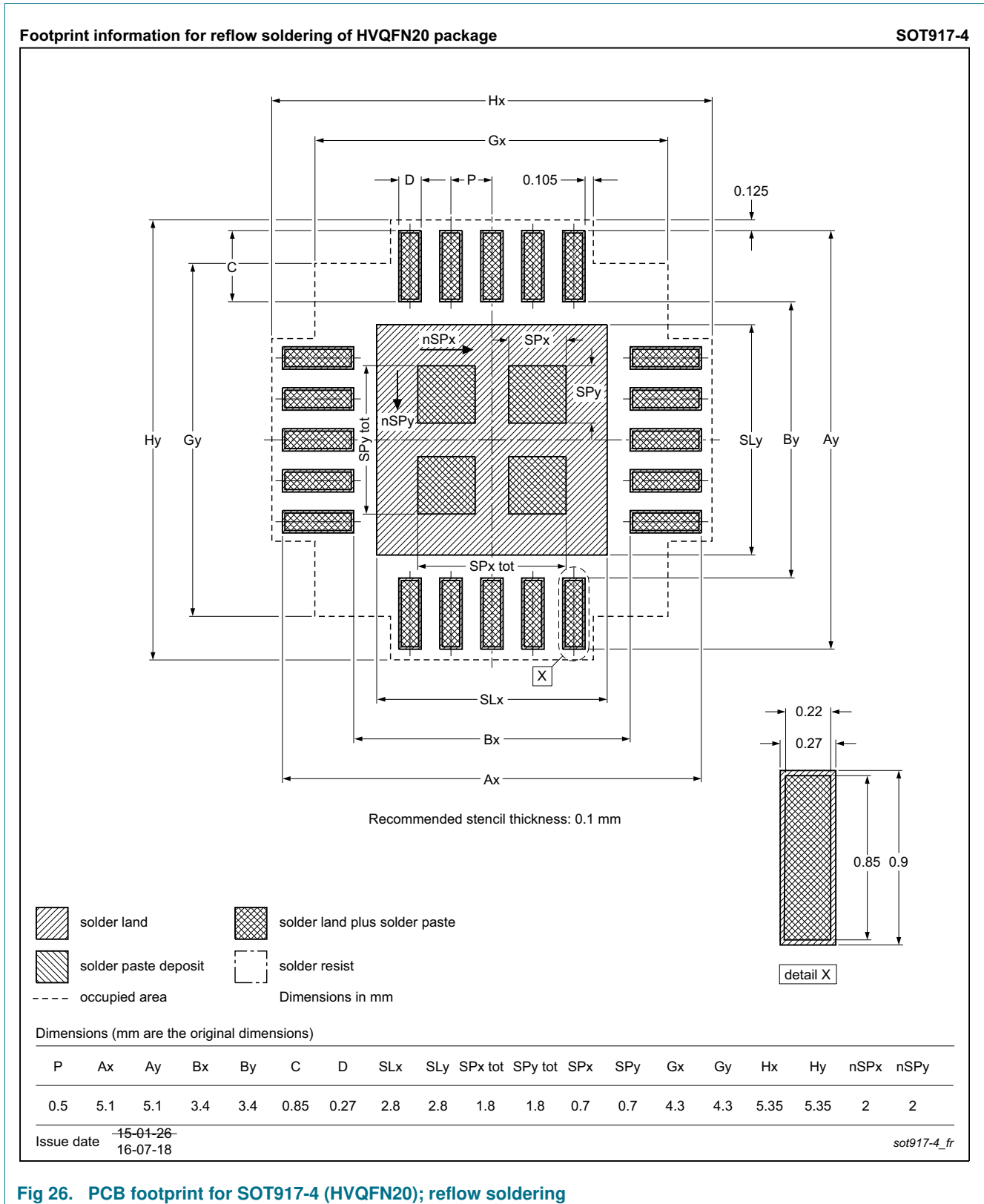

Fig 26. PCB footprint for SOT917-4 (HVQFN20); reflow soldering

16. Abbreviations

Table 21. Abbreviations

Acronym	Description
AP	Application Processor
ASIC	Application Specific Integrated Circuit
CDM	Charged Device Model, an ESD standard
CPU	Central Processing Unit
DBP	Dead Battery Provisioning
DFP	Downstream Facing Port
DRP	Dual Role Port
EC	Embedded Controller
FCP	Forward Current Protection
FS	USB Full Speed signaling
HBM	Human Body Model, an ESD standard
HS	USB High Speed signaling
LDO	Low Drop-Out regulator
LS	USB Low Speed signaling
MM	Machine Model, an ESD standard
OC	Over-Current condition
OCD	Over-Current Detection
PCH	Platform Controller Hub
PD	Power Delivery specification
PMIC	Power Management IC
POR	Power ON Reset
RCP	Reverse Current Protection
SS	USB3.0 Super Speed Signaling
UFP	Upstream Facing Port
USB	Universal Serial Bus

17. References

- [1] USB Power Delivery Specification Revision 2.0, version 1.1, May 2015
- [2] USB Type-C Cable and Connector Specification Revision 1, April 2015
- [3] PTN5100 Application Programming guide
- [4] UM10204, "I²C-bus specification and user manual"; NXP Semiconductors, Revision 03 June 19, 2007

18. Revision history

Table 22. Revision history

Document ID	Release date	Data sheet status	Change notice	Supersedes
PTN5100 v.1.1	20170725	Product data sheet	-	PTN5100 v.1
Modifications:	<ul style="list-style-type: none">Figure 15: Replaced “CBTL04GP043” with “XBAR switch” in Type-C high speed switch block			
PTN5100 v.1	20160801	Product data sheet	-	-

19. Legal information

19.1 Data sheet status

Document status ^{[1][2]}	Product status ^[3]	Definition
Objective [short] data sheet	Development	This document contains data from the objective specification for product development.
Preliminary [short] data sheet	Qualification	This document contains data from the preliminary specification.
Product [short] data sheet	Production	This document contains the product specification.

[1] Please consult the most recently issued document before initiating or completing a design.

[2] The term 'short data sheet' is explained in section "Definitions".

[3] The product status of device(s) described in this document may have changed since this document was published and may differ in case of multiple devices. The latest product status information is available on the Internet at URL <http://www.nxp.com>.

19.2 Definitions

Draft — The document is a draft version only. The content is still under internal review and subject to formal approval, which may result in modifications or additions. NXP Semiconductors does not give any representations or warranties as to the accuracy or completeness of information included herein and shall have no liability for the consequences of use of such information.

Short data sheet — A short data sheet is an extract from a full data sheet with the same product type number(s) and title. A short data sheet is intended for quick reference only and should not be relied upon to contain detailed and full information. For detailed and full information see the relevant full data sheet, which is available on request via the local NXP Semiconductors sales office. In case of any inconsistency or conflict with the short data sheet, the full data sheet shall prevail.

Product specification — The information and data provided in a Product data sheet shall define the specification of the product as agreed between NXP Semiconductors and its customer, unless NXP Semiconductors and customer have explicitly agreed otherwise in writing. In no event however, shall an agreement be valid in which the NXP Semiconductors product is deemed to offer functions and qualities beyond those described in the Product data sheet.

19.3 Disclaimers

Limited warranty and liability — Information in this document is believed to be accurate and reliable. However, NXP Semiconductors does not give any representations or warranties, expressed or implied, as to the accuracy or completeness of such information and shall have no liability for the consequences of use of such information. NXP Semiconductors takes no responsibility for the content in this document if provided by an information source outside of NXP Semiconductors.

In no event shall NXP Semiconductors be liable for any indirect, incidental, punitive, special or consequential damages (including - without limitation - lost profits, lost savings, business interruption, costs related to the removal or replacement of any products or rework charges) whether or not such damages are based on tort (including negligence), warranty, breach of contract or any other legal theory.

Notwithstanding any damages that customer might incur for any reason whatsoever, NXP Semiconductors' aggregate and cumulative liability towards customer for the products described herein shall be limited in accordance with the *Terms and conditions of commercial sale* of NXP Semiconductors.

Right to make changes — NXP Semiconductors reserves the right to make changes to information published in this document, including without limitation specifications and product descriptions, at any time and without notice. This document supersedes and replaces all information supplied prior to the publication hereof.

Suitability for use — NXP Semiconductors products are not designed, authorized or warranted to be suitable for use in life support, life-critical or safety-critical systems or equipment, nor in applications where failure or malfunction of an NXP Semiconductors product can reasonably be expected to result in personal injury, death or severe property or environmental damage. NXP Semiconductors and its suppliers accept no liability for inclusion and/or use of NXP Semiconductors products in such equipment or applications and therefore such inclusion and/or use is at the customer's own risk.

Applications — Applications that are described herein for any of these products are for illustrative purposes only. NXP Semiconductors makes no representation or warranty that such applications will be suitable for the specified use without further testing or modification.

Customers are responsible for the design and operation of their applications and products using NXP Semiconductors products, and NXP Semiconductors accepts no liability for any assistance with applications or customer product design. It is customer's sole responsibility to determine whether the NXP Semiconductors product is suitable and fit for the customer's applications and products planned, as well as for the planned application and use of customer's third party customer(s). Customers should provide appropriate design and operating safeguards to minimize the risks associated with their applications and products.

NXP Semiconductors does not accept any liability related to any default, damage, costs or problem which is based on any weakness or default in the customer's applications or products, or the application or use by customer's third party customer(s). Customer is responsible for doing all necessary testing for the customer's applications and products using NXP Semiconductors products in order to avoid a default of the applications and the products or of the application or use by customer's third party customer(s). NXP does not accept any liability in this respect.

Limiting values — Stress above one or more limiting values (as defined in the Absolute Maximum Ratings System of IEC 60134) will cause permanent damage to the device. Limiting values are stress ratings only and (proper) operation of the device at these or any other conditions above those given in the Recommended operating conditions section (if present) or the Characteristics sections of this document is not warranted. Constant or repeated exposure to limiting values will permanently and irreversibly affect the quality and reliability of the device.

Terms and conditions of commercial sale — NXP Semiconductors products are sold subject to the general terms and conditions of commercial sale, as published at <http://www.nxp.com/profile/terms>, unless otherwise agreed in a valid written individual agreement. In case an individual agreement is concluded only the terms and conditions of the respective agreement shall apply. NXP Semiconductors hereby expressly objects to applying the customer's general terms and conditions with regard to the purchase of NXP Semiconductors products by customer.

No offer to sell or license — Nothing in this document may be interpreted or construed as an offer to sell products that is open for acceptance or the grant, conveyance or implication of any license under any copyrights, patents or other industrial or intellectual property rights.

Export control — This document as well as the item(s) described herein may be subject to export control regulations. Export might require a prior authorization from competent authorities.

Quick reference data — The Quick reference data is an extract of the product data given in the Limiting values and Characteristics sections of this document, and as such is not complete, exhaustive or legally binding.

Non-automotive qualified products — Unless this data sheet expressly states that this specific NXP Semiconductors product is automotive qualified, the product is not suitable for automotive use. It is neither qualified nor tested in accordance with automotive testing or application requirements. NXP Semiconductors accepts no liability for inclusion and/or use of non-automotive qualified products in automotive equipment or applications.

In the event that customer uses the product for design-in and use in automotive applications to automotive specifications and standards, customer (a) shall use the product without NXP Semiconductors' warranty of the

product for such automotive applications, use and specifications, and (b) whenever customer uses the product for automotive applications beyond NXP Semiconductors' specifications such use shall be solely at customer's own risk, and (c) customer fully indemnifies NXP Semiconductors for any liability, damages or failed product claims resulting from customer design and use of the product for automotive applications beyond NXP Semiconductors' standard warranty and NXP Semiconductors' product specifications.

Translations — A non-English (translated) version of a document is for reference only. The English version shall prevail in case of any discrepancy between the translated and English versions.

19.4 Trademarks

Notice: All referenced brands, product names, service names and trademarks are the property of their respective owners.

20. Contact information

For more information, please visit: <http://www.nxp.com>

For sales office addresses, please send an email to: salesaddresses@nxp.com

21. Contents

1	General description	1	8.1.6	USB PD Consumer with Type-C receptacle example	26
2	Features and benefits	2	8.1.6.1	Application description	27
2.1	USB PD and Type-C Features	2	9	Limiting values	28
2.2	System protection features	2	10	Recommended operating conditions	29
2.3	General	2	11	Characteristics	30
3	Applications	3	11.1	Device characteristics	30
4	Ordering information	3	11.2	USB PD and Type-C characteristics	31
4.1	Ordering options	4	11.3	VCONN switch characteristics	32
5	Block diagram	4	11.4	Power AC/DC characteristics	33
6	Pinning information	5	11.5	I2C characteristics	34
6.1	Pinning	5	11.6	SPI characteristics	36
6.2	Pin description	6	11.7	CONTROL IO characteristics	37
7	Functional description	7	12	Package outline	40
7.1	Type-C Configuration Channel functional block	8	13	Packing information	41
7.2	USB Power Delivery Function	9	13.1	SOT917-4: HVQFN20; Reel pack, SMD, 13" Q2/T3 standard product orientation; Orderable part number ending ,128 or HP; Ordering code (12NC) ending 128.	41
7.3	VCONN Switch	10	13.1.1	Packing method	41
7.3.1	Forward Current Protection (FCP)	11	13.1.2	Product orientation	42
7.3.2	Reverse Current Protection (RCP)	11	13.1.3	Carrier tape dimensions	42
7.4	Power FET control	11	13.1.4	Reel dimensions	43
7.5	MCU interface and control	12	13.1.5	Barcode label	44
7.5.1	I2C-bus interface	12	14	Soldering of SMD packages	45
7.5.1.1	I2C writes	12	14.1	Introduction to soldering	45
7.5.1.2	I2C reads	12	14.2	Wave and reflow soldering	45
7.5.1.3	I2C address auto-incrementing	13	14.3	Wave soldering	45
7.5.2	SPI interface	13	14.4	Reflow soldering	46
7.5.3	Register interface	13	15	Soldering: PCB footprints	48
7.5.4	Relevant Interface pins - SLV_ADDR, SPI_CLK_I2C_SCL, SPI_MOSI_I2C_SDA, SPI_CS, SPI_MISO, INT_N	13	16	Abbreviations	49
7.6	Power supplies	13	17	References	49
8	PTN5100 - Use case view	14	18	Revision history	50
8.1	System use cases	15	19	Legal information	51
8.1.1	USB PD Provider/Consumer - Notebook/Ultrabook/Chromebook/Tablet PC	15	19.1	Data sheet status	51
8.1.1.1	Brief description	16	19.2	Definitions	51
8.1.2	USB PD Provider with Type-C receptacle - Desktop PC	18	19.3	Disclaimers	51
8.1.2.1	Brief description	19	19.4	Trademarks	52
8.1.3	USB PD Consumer/Provider (Smartphone use case) - Standalone PTN5100	21	20	Contact information	52
8.1.3.1	Application description	22	21	Contents	53
8.1.4	Type-C cable adapters with PTN5100	23			
8.1.4.1	Application description	23			
8.1.5	USB PD Consumer/Provider with Type-C receptacle	24			
8.1.5.1	Application description	25			

Please be aware that important notices concerning this document and the product(s) described herein, have been included in section 'Legal information'.

© NXP Semiconductors N.V. 2017. All rights reserved.

For more information, please visit: <http://www.nxp.com>
 For sales office addresses, please send an email to: salesaddresses@nxp.com

Date of release: 25 July 2017
 Document identifier: PTN5100