

3mm (T1) Package Discrete LED BLUE



3BW~~X~~-~~X~~

- ◆ Industry Standard 3mm (T1) Package
- ◆ RoHS Compliant
- ◆ Water Clear (C), Diffused (D), and Tinted (T) Lenses
- ◆ Available in Flange (F) and Shouldered (S) Lead Frame Styles
- ◆ Ideal for Status Indication and Display

Bivar 3mm T1 Package LED may be used in almost any application. Bivar offers water clear LED lens for maximum light output, diffused LED lens for uniform light output, and tinted lens to identify the color of the LED. The Flanged LED is ideal for Panel Mount Clip & Ring assemblies. The Shouldered Lead frame LED is ideal for vertical spacer assemblies without lead bends and also has a built in strain relief feature which is ideal for right angle holder assemblies that require lead bends.

Part Number	Material	Emitted Color	Peak. Wavelength λ_p (nm) TYP.	Lens Appearance	Viewing Angle
3BWC-F	GaN/SiC	BLUE	430nm	Water Clear	20°
3BWD-F				Blue Diffused	35°
3BWT-F				Blue Tinted	20°
3BWC-S				Water Clear	30°
3BWD-S				Blue Diffused	40°
3BWT-S				Blue Tinted	30°

Part Number Designation

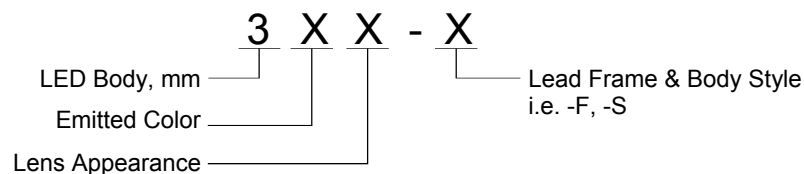

Bivar reserves the right to make changes at any time without notice.

3mm (T1) Package Discrete LED BLUE



Outline Dimensions

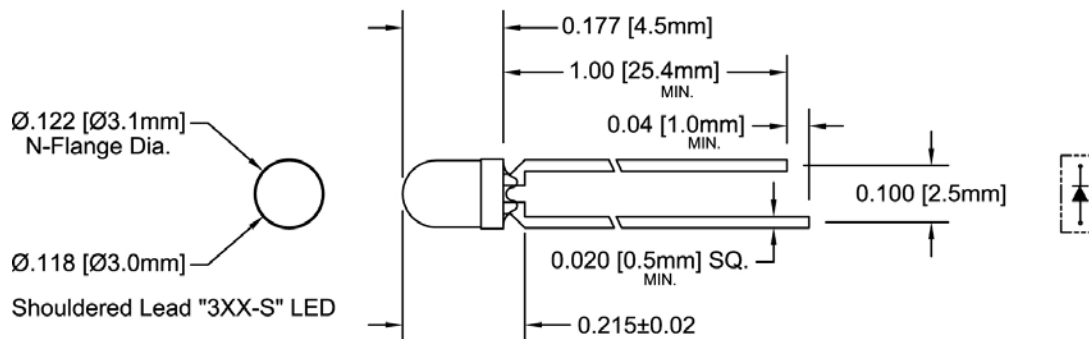
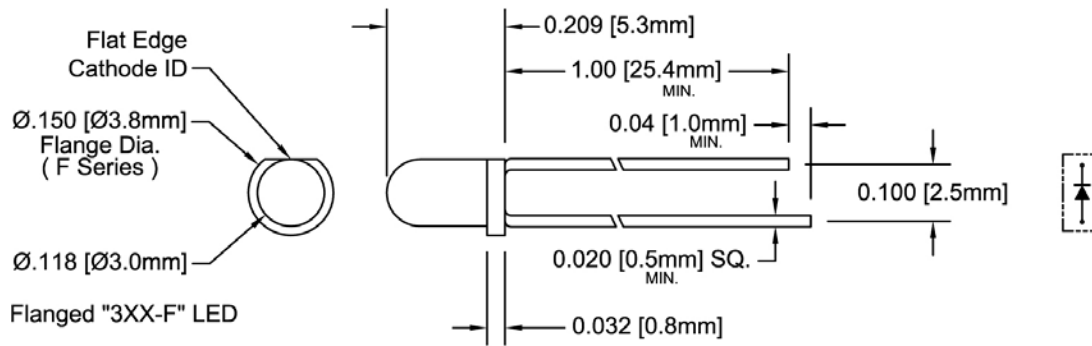

Recommended Mounting
Hole Size = $\text{Ø}0.032^{+0.003}_{-0.002}$

Outline Drawings Notes:

1. All dimensions are in inches [millimeters].
2. Standard tolerance: ± 0.010 " unless otherwise noted.
3. Tolerance of overall epoxy outline: ± 0.020 " unless otherwise noted.
4. Epoxy meniscus may extend to 0.060" max.

Bivar reserves the right to make changes at any time without notice.

Absolute Maximum Ratings

T_A = 25°C unless otherwise noted

Power Dissipation	150 mW
Forward Current (DC)	25 mA
Peak Forward Current ¹	70 mA
Reverse Voltage	5 V
Operating Temperature Range	-25 ~ +85°C
Storage Temperature Range	-30 ~ +100°C
Lead Soldering Temperature (3 mm from the base of the epoxy bulb) ²	260°C

Notes: 1. 10% Duty Cycle, Pulse Width ≤ 0.1 msec. 2. Solder time less than 5 seconds at temperature extreme.

Electrical / Optical Characteristics

T_A = 25°C & I_F = 20 mA unless otherwise noted

Part Number	Forward Voltage (V) ¹			Recommend Forward Current (mA)			Reverse Current (μA)	Dominant Wavelength (nm) ²			Luminous Intensity I _v (mcd)			Viewing Angle 2Θ ½ (deg)
	MIN	TYP	MAX	MIN	TYP	MAX	MAX	MIN	TYP	MAX	MIN	TYP	MAX	TYP
3BWC-F								/	/	/	10	15	30	20
3BWD-F	/	4.0	4.5	/	20	/	100	/	/	/	5	10	20	35
3BWT-F								/	/	/	10	15	30	20
3BWC-S								/	/	/	15	25	50	30
3BWD-S	/	4.0	4.5	/	20	/	100	/	/	/	5	10	20	40
3BWT-S								/	/	/	15	25	50	30

Notes: 1. Tolerance of forward voltage : ±0.05V. 2. Tolerance of dominant wavelength : ±1.0nm.

Typical Electrical / Optical Characteristics

$T_A = 25^\circ\text{C}$ unless otherwise noted

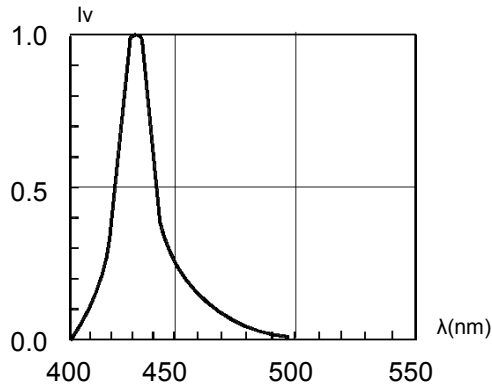

Fig. 1 Relative Luminous Intensity vs. Wavelength @ 20mA

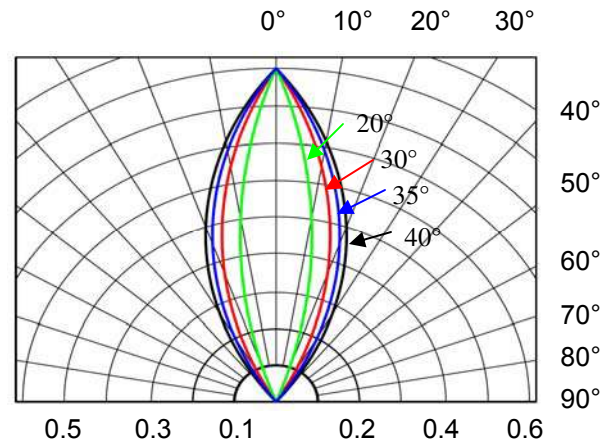

Fig. 2 Directivity Radiation Diagram

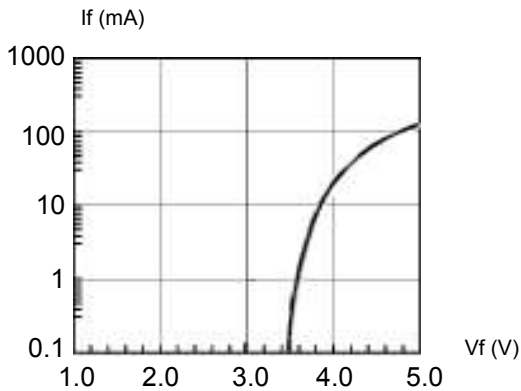

Fig. 3 Forward Current vs. Forward Voltage

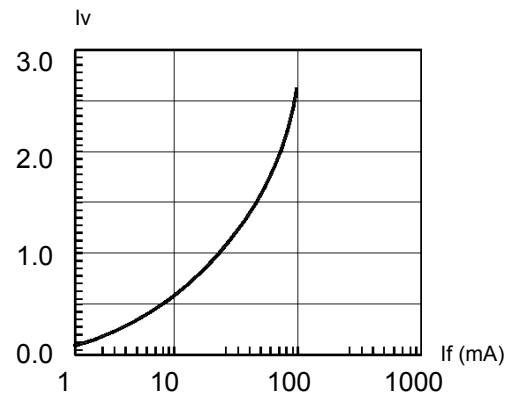

Fig. 4 Relative Luminous Intensity vs. Forward Current Normalize @ 20 mA

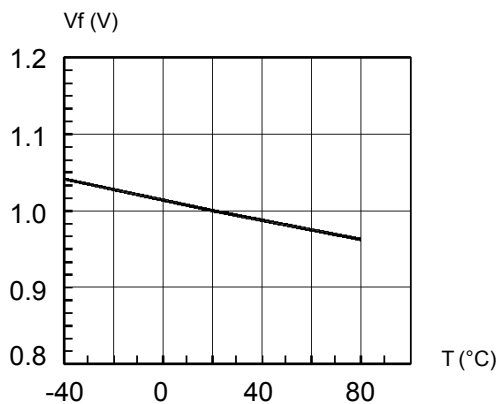

Fig. 5 Forward Voltage vs. Temperature

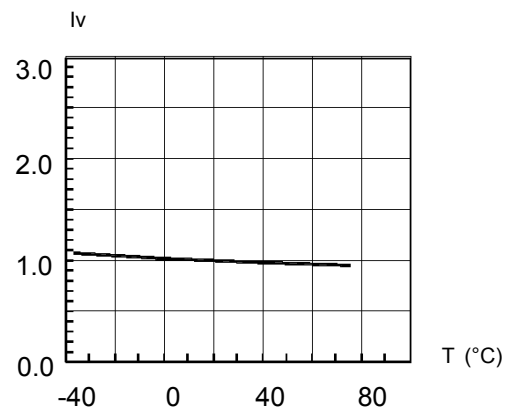

Fig. 6 Relative Luminous Intensity vs. Temperature

Bivar reserves the right to make changes at any time without notice.

3mm (T1) Package Discrete LED BLUE



Recommended Soldering Conditions

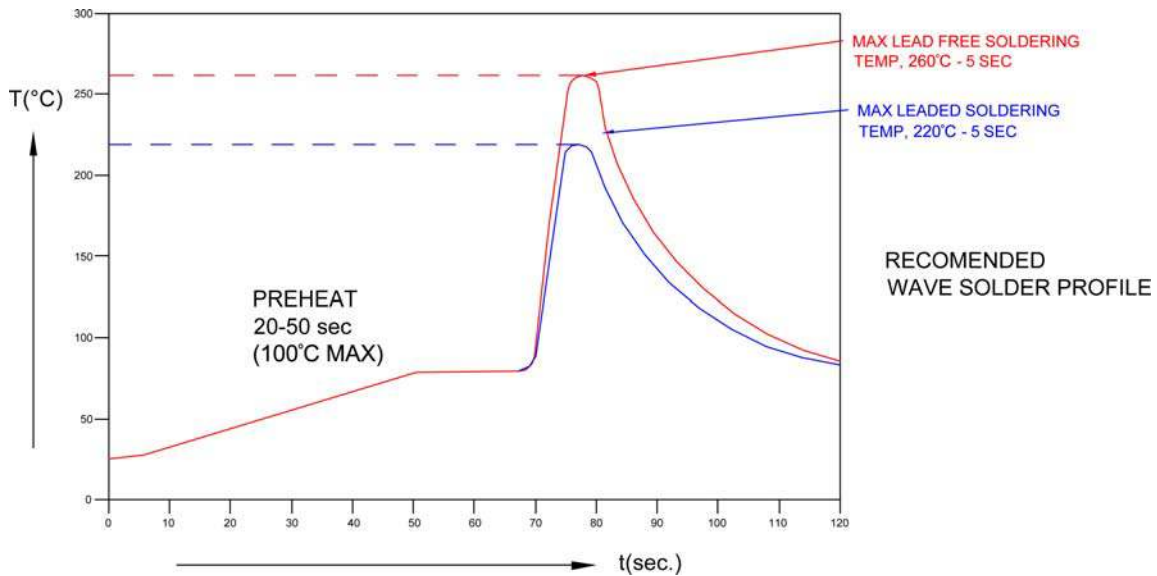

Recommended Lead Free Wave Soldering Profile	
Preheat Temperature: 100°C Max.	Peak Temperature: 260°C Max.
Preheat Time: 20 ~ 50 Seconds	Solder Time Above 217°C: 5 Seconds Max.
Note: Turn off top heater at preheat to prevent the lamp body directly exposed to the heat source.	

Packaging and Labeling Plan



Bivar, Inc. MSL 1

4 Thomas, Irvine, CA 92618-2593
LOT: XXX.XXXXX.XX



Part: **XXXX-XXX-XXX**

Quantity: **.500**

RoHS
Compliant

AntiStatic Poly Bag with Desiccant
(500 pcs Max. per Bag)

Bivar reserves the right to make changes at any time without notice.