

**HS2 L 7 M 26 B - K**

Dura-Pull Series

Connector Type:  
**C** - Cable-End  
**P** - Panel, Front-Mount  
**L** - Cable-to-Cable

# of contacts:  
**2-5** for #20  
**6-9** for #26

Gender:  
**M** - Male (Pin)  
**F** - Female (Socket)

Options:  
**K** - Kit Packaging (one unit/bag)  
**[blank]** - Bulk Packaging  
 Consult factory for other options

Clamp Set per Cable O.D. Range for Cable-End and Cable-to-Cable only:  
**A** - 0.110 - 0.140 [2.8 - 3.6]  
**B** - 0.140 - 0.180 [3.6 - 4.6]  
**C** - 0.180 - 0.216 [4.6 - 5.5]

Contact Size:  
**20** - 20, 22, 24, 26 AWG wires  
**26** - 26, 28, 30 AWG wires

Refer to HS2P SERIES drawing for mating Panel-mount connectors.  
 Refer to HS2C SERIES drawing for mating Cable-End connectors.

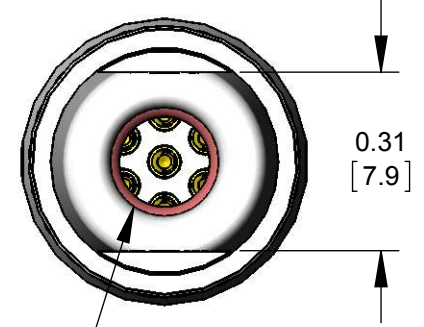
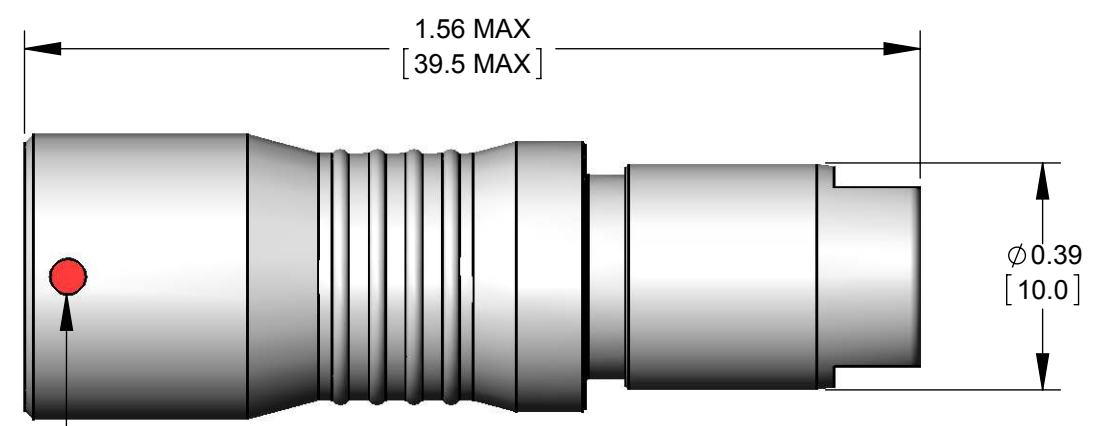
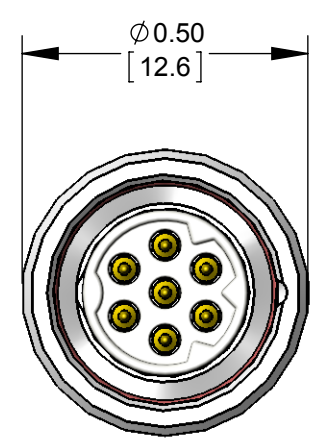
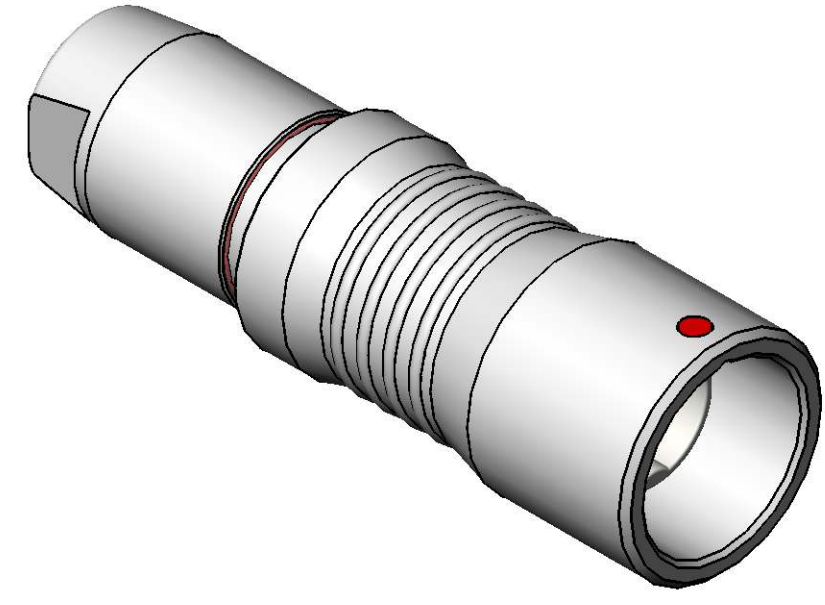

HS2C7M26B SHOWN HERE  
 ALL DIMENSIONS FOR REFERENCE ONLY

CONNECTOR MATING VISUAL AID,  
 STANDARD RED SHOWN

BACK NUT DIA.  
 SIZE A: 0.150 [3.81] DIA.  
 SIZE B: 0.190 [4.83] DIA.  
 SIZE C: 0.230 [5.84] DIA.

SPECIFICATIONS:	
<b>MECHANICAL</b>	
Mating / Locking Type:	Push-Pull automatic locking/unlocking
Life	5,000 cycles minimum
Operating Forces	10 lb. [44.5 N] maximum Insertion or Withdrawal
Vibration	Mil-Std 202G Method 201A
Panel-Mount Hex Nut Tongue	40 in-lb [4.5 Nm] maximum
Cable Securing System:	Threaded on metal Clamp
<b>ELECTRICAL</b>	
Voltage Rating	125 V AC/DC for 2-5 contact arrangements 30 V AC/DC for 6-9 contact arrangements
Current Rating	Refer to Current Carry Capacity Table
Insulation Resistance	1000 MΩ minimum
Contact Resistance	10 mΩ typical
EMI Shielding	360°
<b>ENVIRONMENTAL</b>	
Temperature Limits	-40°C to +135°C (-40°F to +275°F)
Operating Temperature Range	Refer to Current Carry Capacity Table
Moisture Resistance	Mil-Std 202G Method 106G
Insulation Resistance	Mil-Std 202G Method 302
Thermal Shock	Mil-Std 202G Method 107G
Salt Atmosphere (Corrosion)	Mil-Std 202G Method 101E
Ingress Protection Ratings	IP66, IP67, IP68 (6 ft. for 24 hours) per IEC60529, NEMA 250 6P
<b>MATERIAL</b>	
Outer Shell Metal components	Copper Alloy, electroless nickel plated
Hex Nut & Inner Metal components	Copper Alloy, nickel plated
Ground Spring Washer	Stainless Steel
Electrical Insulator	Medical Technology LCP, natural
Seal O-rings	Silicone, red
Contacts	Copper Alloy, gold plated

Contacts	Wire (awg)	Current Rating (A) at Operating Temperature (°C)					Minimum Test Voltage (V rms)	Voltage (V rms) tested per UL2238
		45°C max.	65°C max.	85°C max.	100°C max.	110°C max.		
2 #20	20	10	9	8	7*	6	1400	125
	22	8.5	7.5	7.5	5.5*	4.5		
	24	7	6	5	4.5*	3.5		
	26	4	4	3.5	3.5*	2.5		
3 #20	20	9.5	8.5	7.5	6.5*	5		
	22	8	7	6	5*	4		
	24	6	5.5	4.5	4*	3		
	26	3.5	3.5	3	3*	2.5		
4 #20	20	9	8	7	6*	5		
	22	7.5	6.5	5.5	4.5*	3.5		
	24	5	4.5	4	3.5*	2.5		
	26	3	3	2.5	2.5*	2		
5 #20	20	8	7.5	6.5	5.5*	4.5		
	22	6.5	5.5	5	4*	3		
	24	4.5	4	3.5	3*	2.5		
	26	2.5	2.5	2	2*	1.5		
6-7 #26	26	2.5	2.5	2	2*	1.5		
	28	2	2	1.5	1.5*	1		
	30	1.5	1.5	1	1*	.5		
	26	2	2	1.5	1.5*	1		
8-9 #26	28	1.5	1.5	1	1*	.5		
	30	1	1	.5	.5*	.5		

\*Temperature Rise does not exceed 30°C when tested according to UL2238. All other recommended current ratings are based on the Relative Thermal Index of the insulating material.

**PRELIMINARY**

TOOL	TOOL TYPE	POSITIONER	CONTACT SIZE	WIRE SIZES
EN3CR	HAND CRIMP TOOL	EN2POS20	20 and 22	20 and 22 AWG
		EN3POS26	26	26, 28, and 30 AWG
EN3CRAUTO	PNEUMATIC CRIMP TOOL	EN2POS20	20 and 22	20 and 22 AWG
		EN3POS26	26	26, 28, and 30 AWG
EN2CRL	HAND CRIMP TOOL LARGE FRAME	EN2POS20L	20 and 22	20, 22, 24, and 26 AWG
EN2CRAUTOL	PNEUMATIC CRIMP TOOL LARGE FRAME			
EN3INS20	CONTACT INSERTION	--	20 and 22	20, 22, 24, and 26 AWG
EN3INS26		--	26	26, 28, and 30 AWG
REMT00L20	CONTACT EXTRACTION	--	20	20, 22, 24, and 26 AWG
REMT00L26		--	26	26, 28, and 30 AWG

**CUSTOMER DRAWING**

THIS DRAWING DESCRIBES A DESIGN CONSIDERED PROPRIETARY IN NATURE, DEVELOPED AND MANUFACTURED BY SWITCHCRAFT INC. AND IS RELEASED ON A CONFIDENTIAL BASIS FOR IDENTIFICATION PURPOSES ONLY.

SIZE	WIDTH	MULT	LBS/M	TEMPER
FINISH		MATERIAL		
SPEC No.		SPEC No.		
FIRST USED ON		SCALE		
		3:1		
DATE DRAWN	BY	CHKD	APVD	
01/06/16	PNK	01/06/16	01/06/16	
NAME		PART No.		REV
CABLE-TO-CABLE		HS2 SERIES CONNECTOR		0A
REVISIONS		DO NOT SCALE DRAWING		

UNLESS OTHERWISE SPECIFIED

1. ALL DIMENSIONS IN INCHES [mm]  
 - TWO PLACE DECIMALS ±0.02 [0.5]  
 - THREE PLACE DECIMALS ±0.005 [0.13]

0A PRELIMINARY 01/06/16 PNK SRC

REVISIONS

DO NOT SCALE DRAWING

SolidWorks CAD File

# HS2 SERIES CABLE-TO-CABLE FIELD ASSEMBLY INSTRUCTIONS:

1. FEED THE FREE END OF CABLE THROUGH THE NUT, O-RING, WASHER, AND CLAMP IN THE ORDER SHOWN.
2. STRIP THE CABLE END AND THE CONDUCTORS AS SHOWN HERE.

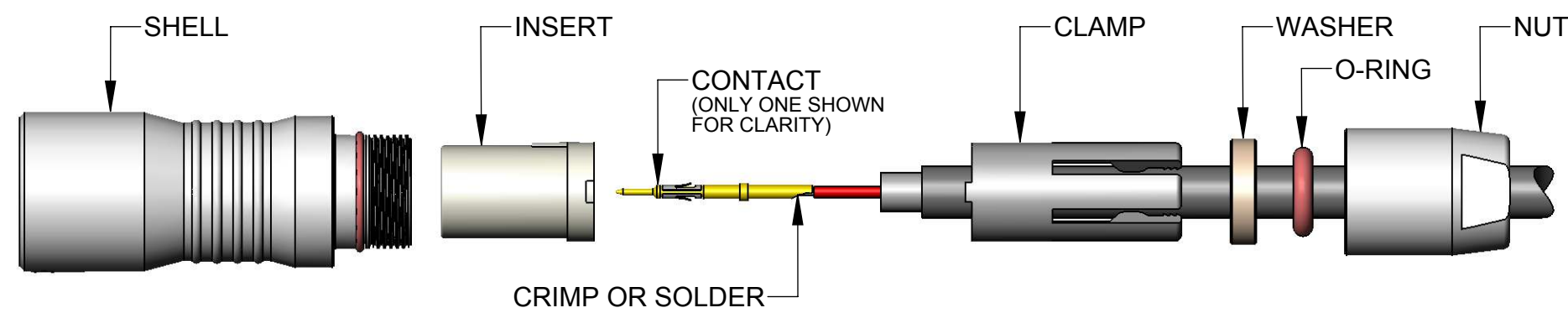
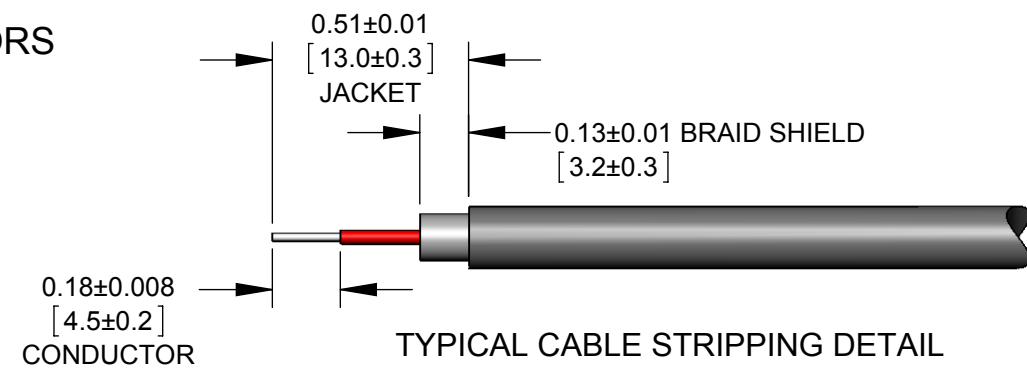

3. CRIMP CONDUCTORS TO CONTACTS USING HAND OR PNEUMATIC CRIMP TOOL\* WITH CRIMP POSITIONER\* SET PER CONTACT SIZE AND WIRE GAGE. IF SOLDERING, IT IS RECOMMENDED TO SOLDER CONDUCTORS TO CONTACTS BEFORE INSERTING THEM INTO INSERT.
4. GUIDE EACH WIRED CONTACT INTO INSERT HOLE AND PUSH UNTIL CONTACT SNAPS IN PLACE. USE INSERTION TOOL\* IF NECESSARY. COLORED CONDUCTORS CAN BE ASSIGNED TO CONTACT POSITION NUMBERS AS DESIRED. TO REMOVE A CONTACT, INSERT THE EXTRACTION TOOL\* FROM THE FRONT OF INSERT AND LIGHTLY PRESS THE SPRING LOADED PLUNGER INWARD TO PUSH THE CONTACT OUT.

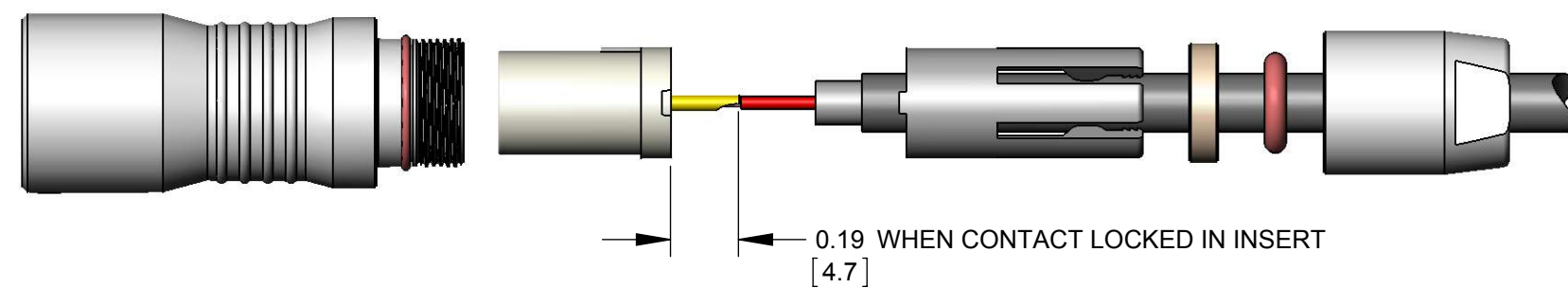

5. ALIGN INSERT ASSEMBLY INTO SHELL FOLLOWED BY THE CLAMP. PUSH CLAMP LIGHTLY FORWARD AND ROTATE UNTIL THE ASSEMBLY SNAPS IN THE FINAL POSITION SHOWN.

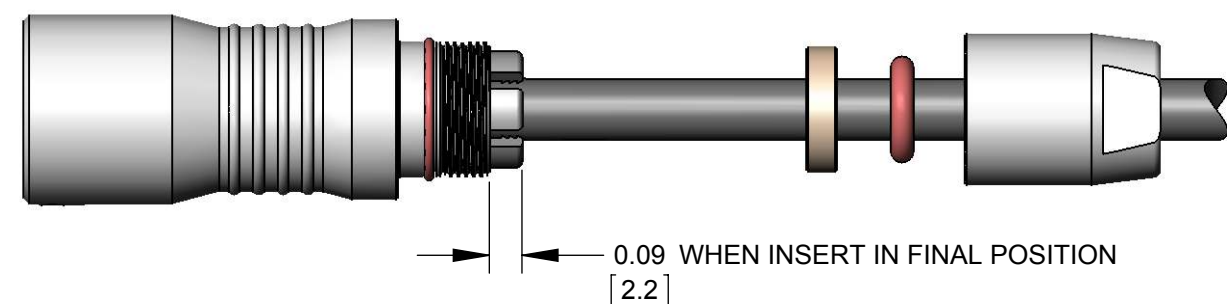

6. SLIDE WASHER, O-RING, AND NUT AGAINST CLAMP AND THREAD NUT ON UNTIL TIGHT, UP TO 12 IN-LB [1.4 Nm] TORQUE. A 5/16" [8mm] WRENCH CAN BE USED, IF NECESSARY.

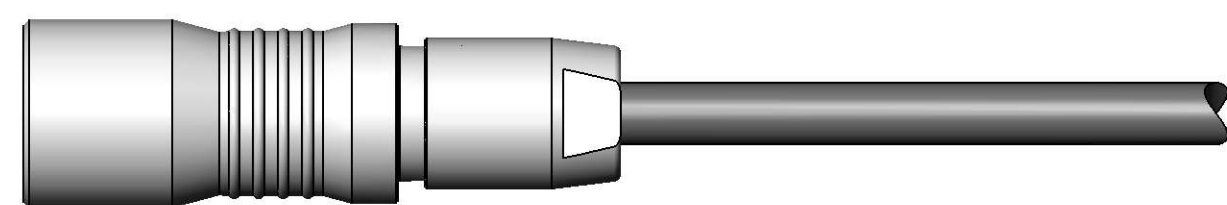

\*REFER TO TOOLS TABLE ON THIS DRAWING FOR SELECTION OF TOOLS PER CONTACT AND WIRE SIZE.

SCALE 2:1	Switchcraft®	
DATE DRAWN *		
DRAWN BY *	PART No. HS2L SERIES_CD	REV *
SHEET 2 OF 2		