

CLASSIFICATION	SPECIFICATIONS	No. 151S-ECJ-KI609E
SUBJECT	Low ESR Type Multilayer Ceramic Chip Capacitor "1632" Type (EIA 0612 type) Individual Specification	PAGE 1 of 2
		DATE 21-Sep-01

1. Scope

This specification applies to MATSUSHITA'S Low ESR Type Multilayer Ceramic Chip Capacitor "1632" Type (EIA 0612Type) rated voltage 16VDC..

2. Style and Dimensions

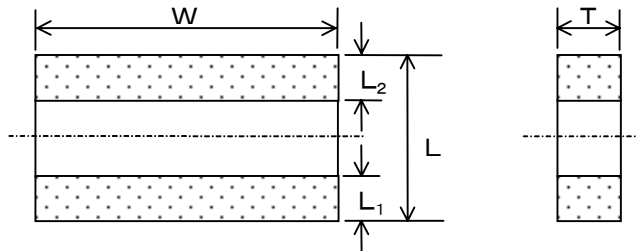

Table 1

Symbol	Dimensions(mm)
L	1.60 +/- 0.20
W	3.20 +/- 0.20
T	0.85 +/- 0.10
L1,L2	0.30 +/- 0.20

3. Operating Temperature Range

Table 2

	Temperature Characteristics	Operating Temp. Range.
Class2	X7R (334)	-55 to +125°C
	X5R (105)	-55 to +85°C

4. Individual Specification

Table 3

Part Number	Rated Voltage	Temp.Char.	Nominal Capacitance	Cap. Tolerance	Tan δ
ECY39RC334□◇	16V D.C.	X7R	0.33 uF	+/-10% or +/-20%	0.025 max
ECY39RC105□◇	16V D.C.	X5R	1.0 uF	+/-10% or +/-20%	0.025 max

5. Explanation of Part Numbers

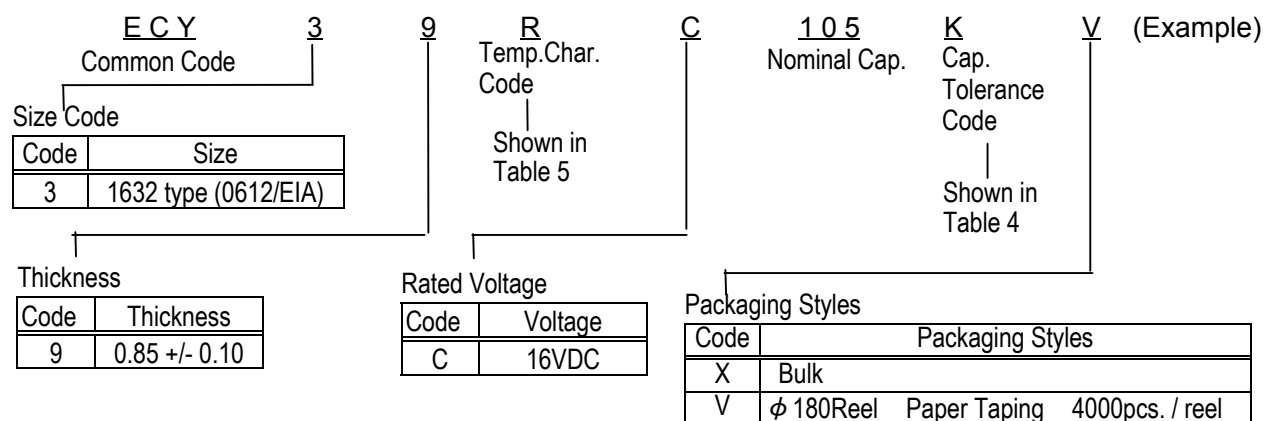

Note :

CERAMIC BUSINESS UNIT LCR DEVICE COMPANY
MATSUSHITA ELECTRONIC COMPONENTS CO., LTD.
KADOMA, OSAKA, JAPAN

APPROVAL

CHECK

DESIGN

CLASSIFICATION	SPECIFICATIONS	NO. 151S-ECJ- KI609E
SUBJECT	Low ESR Type Multilayer Ceramic Chip Capacitor "1632" Type (EIA 0612 Type) Individual Specification	PAGE
		DATE

2 of 2
21-Sep-01

6. Capacitance Tolerance

Table 4

Part No. Code	Cap. Tolerance	Temp. Char.	Class
K	+/- 10%	X7R	2
M	+/- 20%	X5R	

7. Temperature Characteristics

Temperature Characteristics of Class 2 Capacitors

Table 5

Temp. Char. Code	Capacitance Change rate from Temperature			Measurement Temperature Range	Reference Temperature
	Temp. Char.	Without voltage application	With 1/2 Rated voltage application		
R	X7R (334)	± 15%	---	-55 to +125°C	+25°C
	X5R (105)	± 15%	---	-55 to +85°C	+25°C

8. Soldering method

Soldering method of Multilayer ceramic chip capacitor shall be reflow soldering.

9. Part Number List

Table 5

Capacitance (uF)	B	
	16VDC	
	Part Number	T (mm)
0.33	ECY39RC334□V	0.85
1.0	ECY39RC105□V	0.85

* □ : Capacitance Tolerance Code ; K(±10%) or M(±20%)

Note