

REVISIONS					
P	LTR	DESCRIPTION	DATE	DWN	APVD
	A1	REVISED PER ECO-10-010249	15MAY2010	HMR	NE
	A2	ECR-22-156505	27JAN2023	KW	MD

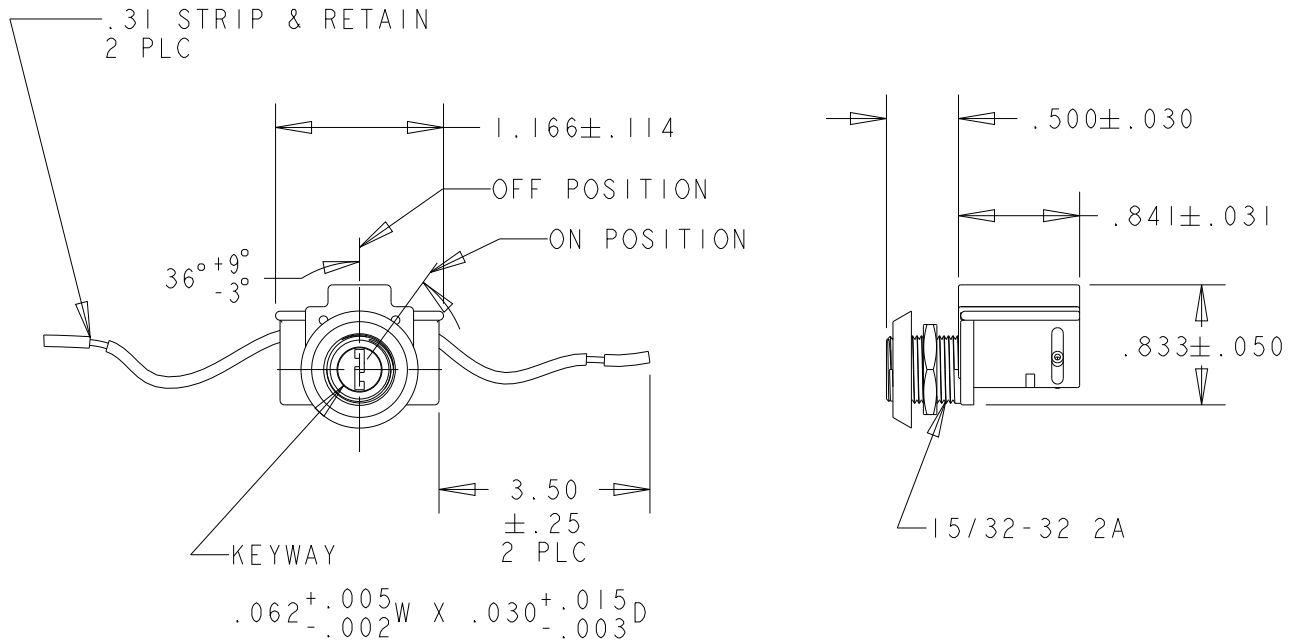

NOTES:

- KEY REMOVABLE BOTH POSITIONS.
- KEYSWITCH SUPPLIED WITH 1 HEX NUT, 1 DRESS NUT AND 1 KEY.
- WIRE: 18 AWG BOND WIRE, TINNED, PVC INSULATED, W/ 80°C AND 300 V RATING (UL 1007).  
CONTACT MATERIAL: MOVABLE-BRONZE, SILVER PLATED;  
STATIONARY-BRASS, SILVER PLATED.  
CIRCUIT: SPST  
ACTION: OFF-ON
- ELECTRICAL SPECIFICATIONS:  
KEYSWITCH RATING: 6A, 125V AC; 3A, 250V AC  
DIELECTRIC VOLTAGE: 1000V RMS MIN.  
INSULATION RESISTANCE: 100 MΩ MIN.  
CONTACT RESISTANCE: 100 mΩ MAX.  
CYCLE LIFE: 6000 OPERATIONS MIN.  
TEMPERATURE RISE: <30°C AT 6000 OPERATIONS

- ENVIRONMENTAL SPECIFICATIONS:  
OPERATING TEMP: -18°C TO 65°C
- 6 UL/CSA RECOGNITION.
- 7 TYCO ELECTRONICS LOGO PER TEC-202-36 LOCATED APPROXIMATELY AS SHOWN

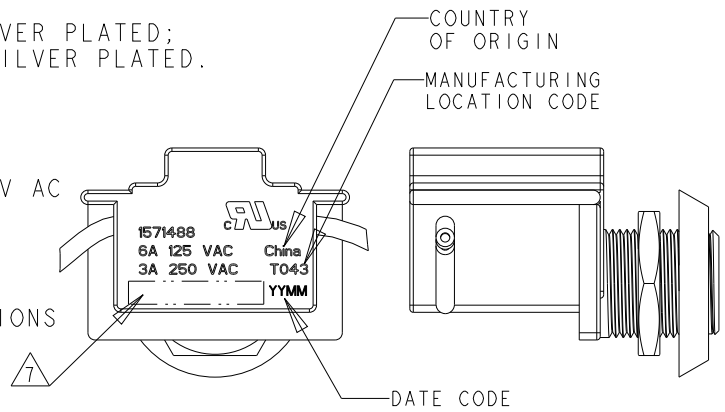

SCALE 6:5

© 2023 TE Connectivity. All Rights Reserved.

1571488-1	PART NUMBER
-----------	-------------

DIMENSIONS: INCHES	DWN J.C. YOSLER	11NOV2003	MATERIAL	-	FINISH	-
	CHK J.C. YOSLER	11NOV2003	<b>TE</b> TE Connectivity			
TOLERANCES UNLESS OTHERWISE SPECIFIED:	APVD M. WILBOURN	07NOV2006				
0 PLC ±	PRODUCT SPEC	-	NAME	KEYSWITCH SPST		
1 PLC ±.03	APPLICATION SPEC	-	SIZE	CAGE CODE	DRAWING NO	RESTRICTED TO
2 PLC ±.015			A4	00779	C-1571488	-
3 PLC ±.010						
4 PLC ±						
ANGLES ±1/2	WEIGHT	-				
	CUSTOMER DRAWING		SCALE	3:4	SHEET	1 OF 1
						REV A2