

NHD-12232DZ-FSW-GBW

Graphic Liquid Crystal Display Module

NHD-	Newhaven Display
12232-	122 x 32 pixels
DZ-	Model
F-	Transflective
SW-	Side White LED Backlight
G-	STN- Gray
B-	6:00 view
W-	Wide Temperature (-20°C ~+70°C)
	RoHS Compliant

Newhaven Display International, Inc.

2511 Technology Drive, Suite 101

Elgin IL, 60124

Ph: 847-844-8795

Fax: 847-844-8796

www.newhavendisplay.com

nhtech@newhavendisplay.com

nhsales@newhavendisplay.com

Document Revision History

Revision	Date	Description	Changed by
0	5/19/2008	Initial Release	-
1	3/12/2010	User guide reformat	BE
2	4/14/2010	Pin description updated	BE

Functions and Features

- 122 x 32 pixels
- Built-in AX6120 Controller
- +5.0V power supply
- 1/32 duty cycle; 1/6 bias
- RoHS Compliant

Mechanical Drawing

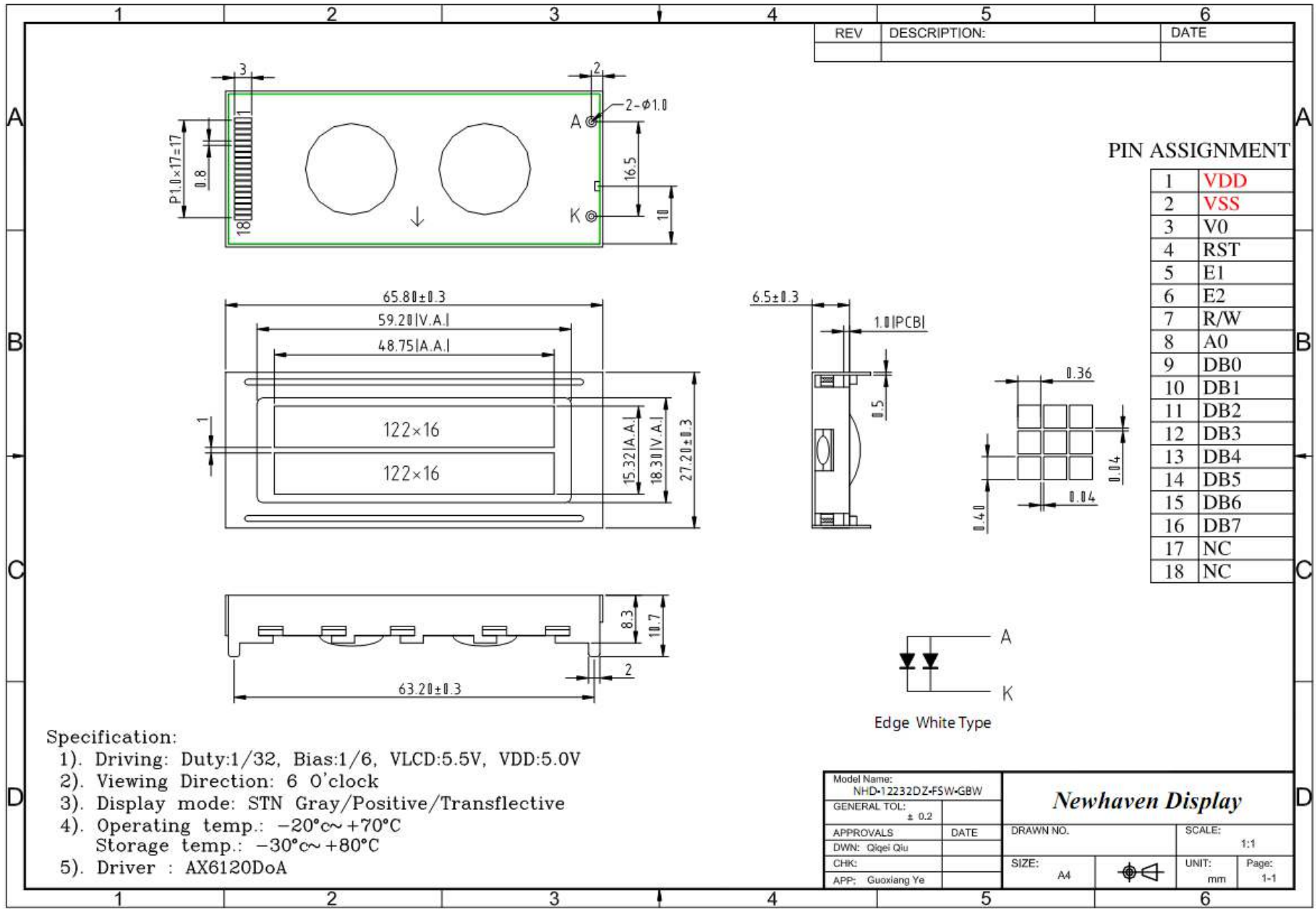

REV	DESCRIPTION:	DATE

PIN ASSIGNMENT

1	VDD
2	VSS
3	V0
4	RST
5	E1
6	E2
7	R/W
8	A0
9	DB0
10	DB1
11	DB2
12	DB3
13	DB4
14	DB5
15	DB6
16	DB7
17	NC
18	NC

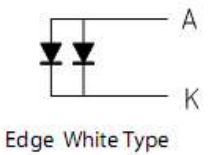

Specification:

- 1). Driving: Duty:1/32, Bias:1/6, VLCD:5.5V, VDD:5.0V
- 2). Viewing Direction: 6 O'clock
- 3). Display mode: STN Gray/Positive/Transflective
- 4). Operating temp.: $-20^{\circ}\text{C} \sim +70^{\circ}\text{C}$
Storage temp.: $-30^{\circ}\text{C} \sim +80^{\circ}\text{C}$
- 5). Driver : AX6120DoA

Model Name: NHD-12232DZ-FSW-GBW		Newhaven Display	
GENERAL TOL: ± 0.2			
APPROVALS	DATE	DRAWN NO.	SCALE: 1:1
DWN: Qiwei Qiu		SIZE: A4	UNIT: mm
CHK:			Page: 1-1
APP: Guoxiang Ye			

Pin Description and Wiring Diagram

Pin No.	Symbol	External Connection	Function Description
1	VDD	Power Supply	Power supply for logic (+5.0V)
2	VSS	Power Supply	Ground
3	V0	Adj Power Supply	Power supply for contrast (approx.- 0.5V)
4	RST	MPU	Active low Reset
5	E1	MPU	Operation enable signal. Falling edge triggered, SEG (1~60)
6	E2	MPU	Operation enable signal. Falling edge triggered, SEG (61~120)
7	R/W	MPU	Read/Write select signal, R/W=1: Read R/W: =0: Write
8	A0	MPU	Register select signal. A0=0: Command, A0=1: Data
9-16	DB0-DB7	MPU	This is an 8-bit bi-directional data bus
17	NC	-	No Connect
18	NC	-	No Connect
A	LED+	Power Supply	Power supply for LED Backlight (+3.0V)
K	LED-	Power Supply	Ground for Backlight

Recommended LCD connector: 1.0mm pitch pins

Backlight connector: - Mates with: -

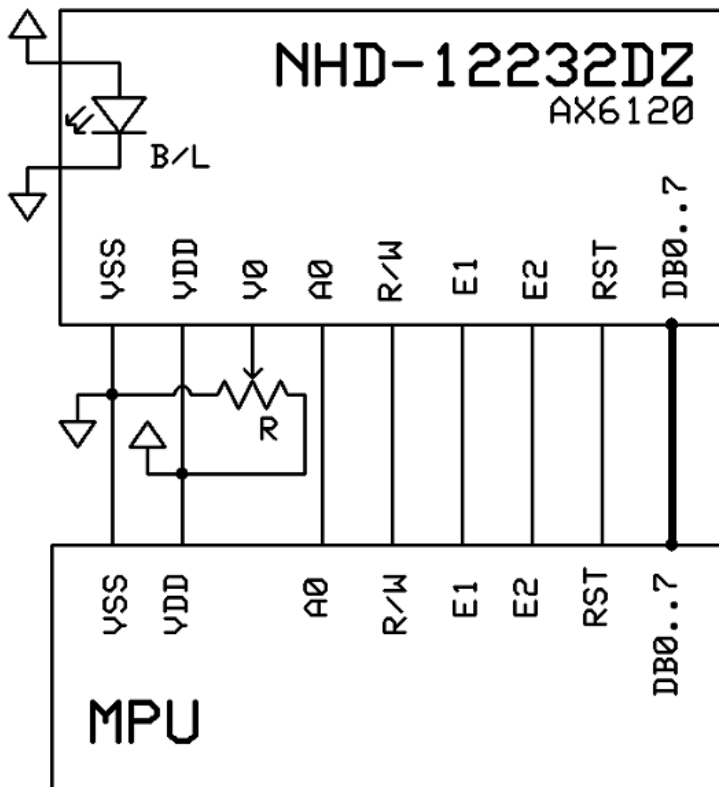

Electrical Characteristics

Item	Symbol	Condition	Min.	Typ.	Max.	Unit
Operating Temperature Range	Top	Absolute Max	-20	-	+70	°C
Storage Temperature Range	Tst	Absolute Max	-30	-	+80	°C
Supply Voltage	VDD		4.7	5.0	5.5	V
Supply Current	IDD	Ta=25°C, VDD=5.0V	-	1.2	1.5	mA
Supply for LCD (contrast)	VDD-V0	Ta=25°C	-	5.5	-	V
"H" Level input	VIH		2.2	-	VDD	V
"L" Level input	VIL	-	0	-	0.6	V
"H" Level output	VOH	-	2.4	-	-	V
"L" Level output	VOL	-	-	-	0.4	V
Backlight Supply Voltage	VLED		-	3.0	-	V
Backlight Supply Current	ILED	VLED=3.0V	-	36	-	mA

Optical Characteristics

Item	Symbol	Condition	Min.	Typ.	Max.	Unit
Viewing Angle - Vertical (top)	AV	Cr ≥ 3	-	10	-	
Viewing Angle – Vertical (bottom)	AV	Cr ≥ 3	-	60	-	°
Viewing Angle – Horizontal (left)	AH	Cr ≥ 3	-	45	-	
Viewing Angle - Horizontal (right)	AH	Cr ≥ 3	-	45	-	°
Contrast Ratio	Cr		-	5	-	-
Response Time (rise)	Tr	-	-	100	150	ms
Response Time (fall)	Tf	-	-	150	200	ms

Controller Information

Built-in AX6120. Download specification at http://www.newhavendisplay.com/app_notes/AX6120.pdf

Timing Characteristics

- MPU Bus Read/Write i (80-family MPU)

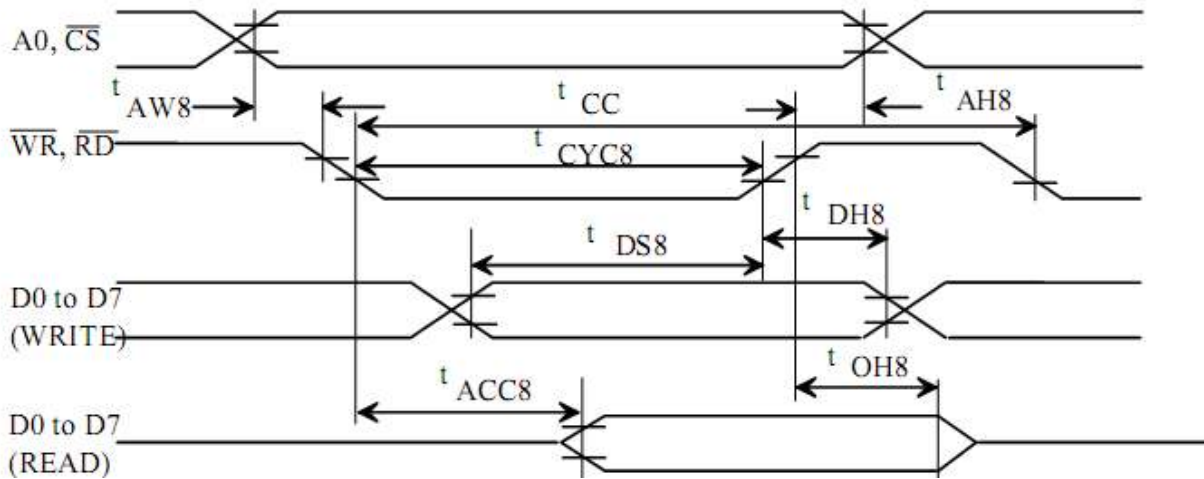

$T_a = -20$ to 75 deg. C, $V_{SS} = -1.0 \pm 10\%$ unless stated otherwise

Parameter	Symbol	Condition	Rating		Unit	Signal
			min	max		
Address hold time	t_{AH8}		10	--	ns	A0, CS
Address setup time	t_{AW8}		20	--	ns	
System cycle time	t_{CYC8}		1,000	--	ns	WR, RD
Control pulsewidth	t_{CC}		200	--	ns	
Data setup time	t_{DS8}		80	--	ns	D0 to D7
Data hold time	t_{DH8}		10	--	ns	
RD access time	t_{ACC8}	CL = 100pF	--	90	ns	
Output disable time	t_{CH8}		10	60	ns	

Notes : 1. Increase parameter values by 200% when $V_{SS} = -3.0V$.

2. All inputs must have a rise and fall time of less than 15 ns.

• MPU Bus Read/Write II (68-family MPU)

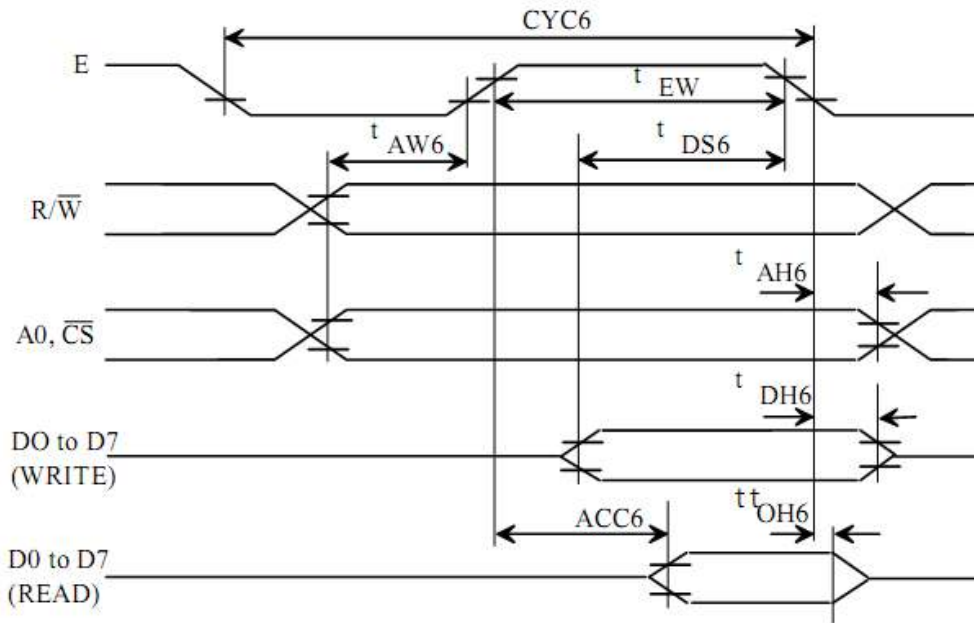

Ta= -20 to 75 deg. C. Vss= -5V ± 10 unless stated otherwise

Parameter	Symbol	Condition	Rating		Unit	Signal
			min	max		
System cycle time	tCYC6		1,000	--	ns	A0, \bar{CS} , R/ \bar{W}
Address setup time	tAW6		20	--	ns	
Address hold time	tAH6		10	--	ns	
Data setup time	tDS6		80	--	ns	D0 to D7
Data hold time	tDH6		10	--	ns	
Output disable time	tOH6		10	60	ns	
Access time	tACC6	CL= 100pF	--	90	ns	
Enable pulsewidth	Read	tEW	100	--	ns	E
	Write		8	--	ns	

- Notes :
1. tCYC6 is the cycle time of \bar{CS} . E=H. not the cycle time of E.
 2. Increase parameter values by 200% when Vss= -3.0V.
 3. all inputs must have a rise and fall time of less than 15 ns.

Table of Commands

Command	Code											Function
	A0	\overline{RD}	\overline{WR}	D7	D6	D5	D4	D3	D2	D1	D0	
Display On/Off	0	1	0	1	0	1	0	1	1	1	0/1	Turns display on or off. 1 : ON, 0 : OFF
Display start line	0	1	0	1	1	0	Display start address (0 to 31)				Specifies RAM line corresponding to top line of display.	
Set page address	0	1	0	1	0	1	1	1	0	Page (0 to 3)		Sets display RAM page in page address register.
Set column (segment) address	0	1	0	0	Column address (0 to 79)						Sets display RAM column address in column address register.	
Read status	0	0	1	Busy	ADC	ON/OFF	Reset	0	0	0	0	Reads the following status : BUSY 1 : Busy 0 : Ready ADC 1 : CW output 0 : CCW output ON/OFF 1 : Display off 0 : Display on RESET 1 : Being reset 0 : Normal
Write display data	1	1	0	Write data							Writes data from data bus into display RAM.	
Read display data	1	0	1	Read data							Reads data from display RAM onto data bus.	
Select ADC	0	1	0	1	0	1	0	0	0	0	0/1	0 : CW output, 1 : CCW output
Static drive ON/OFF	0	1	0	1	0	1	0	0	1	0	0/1	Selects static driving operation. 1 : Static drive, 0 : Normal driving
Select duty	0	1	0	1	0	1	0	1	0	0	0/1	Selects LCD duty cycle 1 : 1/32, 0 : 1/16
Read-Modify-Write	0	1	0	1	1	1	0	0	0	0	0	Read-modify-write ON
End	0	1	0	1	1	1	0	1	1	1	0	Read-modify-write OFF
Reset	0	1	0	1	1	1	0	0	0	1	0	Software reset

Example Initialization Program:

```
/******  
void Comleft(char i)  
{  
  P1 = i;  
  R_W = 0;  
  D_I = 0;  
  E1 = 1;  
  delay(2);  
  E1 = 0;  
}  
  
void Comright(char i)  
{  
  P1 = i;  
  R_W = 0;  
  D_I = 0;  
  E2 = 1;  
  delay(2);  
  E2 = 0;  
}  
  
void Writeleft(char i)  
{  
  P1 = i;  
  R_W = 0;  
  D_I = 1;  
  E1 = 1;  
  delay(2);  
  E1 = 0;  
}  
  
void Writerright(char i)  
{  
  P1 = i;  
  R_W = 0;  
  D_I = 1;  
  E2 = 1;  
  delay(2);  
  E2 = 0;  
}  
/******  
void bothSides(char i)  
{  
  Comleft(i);  
  Comright(i);  
}  
/******  
  
void init()  
{  
  P1 = 0;  
  P3 = 0;  
  RST = 0; //      Reset RST  
  delay(1);  
  RST = 1; //      Reset RST= M68 Interface  
  delay(10);  
  D_I = 0;  
  E1 = 1;  
  E2 = 1;  
  R_W = 1;  
  
  bothSides(0xE2);  
  delay(10);  
  bothSides(0xA4);  
  bothSides(0xA9);  
  bothSides(0xA0);  
  bothSides(0xEE);  
  bothSides(0xC0);  
  bothSides(0xAF);  
}  
/******
```

Quality Information

Test Item	Content of Test	Test Condition	Note
High Temperature storage	Endurance test applying the high storage temperature for a long time.	+80°C , 200hrs	2
Low Temperature storage	Endurance test applying the low storage temperature for a long time.	-30°C , 200hrs	1,2
High Temperature Operation	Endurance test applying the electric stress (voltage & current) and the high thermal stress for a long time.	+70°C 200hrs	2
Low Temperature Operation	Endurance test applying the electric stress (voltage & current) and the low thermal stress for a long time.	-20°C , 200hrs	1,2
High Temperature / Humidity Operation	Endurance test applying the electric stress (voltage & current) and the high thermal with high humidity stress for a long time.	+60°C , 90% RH , 96hrs	1,2
Thermal Shock resistance	Endurance test applying the electric stress (voltage & current) during a cycle of low and high thermal stress.	-20°C,30min -> 25°C,5min -> 70°C,30min = 1 cycle 10 cycles	
Vibration test	Endurance test applying vibration to simulate transportation and use.	10-55Hz , 15mm amplitude. 60 sec in each of 3 directions X,Y,Z For 15 minutes	3
Static electricity test	Endurance test applying electric static discharge.	VS=800V, RS=1.5kΩ, CS=100pF One time	

Note 1: No condensation to be observed.

Note 2: Conducted after 4 hours of storage at 25°C, 0%RH.

Note 3: Test performed on product itself, not inside a container.

Precautions for using LCDs/LCMs

See Precautions at www.newhavendisplay.com/specs/precautions.pdf

Warranty Information and Terms & Conditions

http://www.newhavendisplay.com/index.php?main_page=terms