

PART NUMBER	REVISION	DESCRIPTION	FEED TYPE
2266115-1	D	FINE CRIMP HEIGHT ADJUST	MECHANICAL
2266115-2	D	FINE CRIMP HEIGHT ADJUST	PNEUMATIC
5-2266115-1	D	SEAL STRIPPER CRIMPER TERMINATING UNIT	MECHANICAL
5-2266115-2	D	SEAL STRIPPER CRIMPER TERMINATING UNIT	PNEUMATIC
7-2266115-1	D	MECHANICAL AND CRIMP TOOLING KIT	MECHANICAL
7-2266115-2	D	PNEUMATIC AND CRIMP TOOLING KIT	PNEUMATIC
7-2266115-7	B	CRIMP TOOLING KIT	-
7-2266115-8	B	APPLICATOR CONVERSION KIT	-

ATLANTIC VERSION TERMINATOR INTERFACE ADAPTER

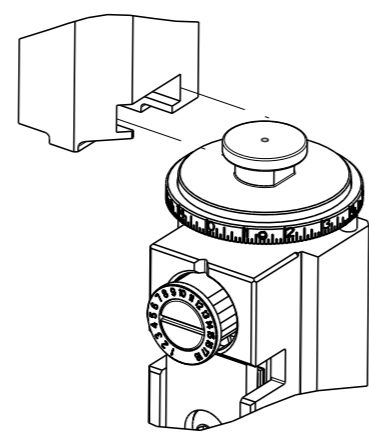

APPLICATOR DATA		
CRIMP	SIZE	TYPE
WIRE	2.62 mm [.103]	F
INSUL	2.03 mm [.080]	O

APPLICATOR CONVERSION KITS	
PART NUMBER	INSULATION DIAMETER RANGE
7-2266112-8	Ø3.15-3.56mm [.124-.140]
7-2266113-8	Ø2.72-3.12mm [.107-.123]
7-2266114-8	Ø2.29-2.69mm [.090-.106]
7-2266115-8	Ø1.91-2.26mm [.075-.089]

TERMINAL DATA: DEUTSCH TERMINAL		TE CRIMP SPECIFICATION	
TERMINAL NAME: STAMPED CONTACT PIN SIZE 16			
WIRE STRIP LENGTH		INSULATION DIAMETER RANGE	
4.44-5.72 mm [.175-.225 IN]		Ø1.91-2.26 mm [.075-.089 IN]	
TERMINAL APPLICATION SPECIFICATION	114-151001		
TERMINALS APPLIED			
TE TERMINAL	DEUTSCH TERMINAL	TE TERMINAL	DEUTSCH TERMINAL
2113238-1	1060-16-1222	2113238-2	1060-16-1244
2113238-3	1060-16-1277		

TERMINAL DATA: DEUTSCH TERMINAL		TE CRIMP SPECIFICATION	
TERMINAL NAME: STAMPED CONTACT SOCKET SIZE 16			
WIRE STRIP LENGTH		INSULATION DIAMETER RANGE	
4.44-5.72 mm [.175-.225 IN]		Ø1.91-2.26 mm [.075-.089 IN]	
TERMINAL APPLICATION SPECIFICATION	114-151001		
TERMINALS APPLIED			
TE TERMINAL	DEUTSCH TERMINAL	TE TERMINAL	DEUTSCH TERMINAL
1949119-1	1062-16-1222	1949119-2	1062-16-1244
1949119-3	1062-16-1277	1949119-4	1062-16-1422
1949119-5	1062-16-1444	1949119-6	1062-16-1477

WIRE SIZE	CRIMP HEIGHT mm [INCH]	CRIMP HEIGHT REFERENCE SETTING
14 AWG	1.65+0.03/-0.05 [0.065+0.001/-0.002]	6.1
2.00mm2	1.63+0.03/-0.05 [0.064+0.001/-0.002]	6.3
1.50mm2	1.50+0.03/-0.05 [0.059+0.001/-0.002]	7.6
16 AWG	1.47+0.03/-0.05 [0.058+0.001/-0.002]	7.9
1.00mm2	1.40+0.03/-0.05 [0.055+0.001/-0.002]	8.6

- RECOMMENDED SPARE PARTS
- REFER TO SUPPLIED INSTRUCTION SHEET FOR CLEANING, LUBRICATION AND STORAGE OF APPLICATOR.
- APPLY PART NUMBER 2-23419-6 LOCTITE TO THREADS OF ITEM 242. APPLY PART NUMBER 1-23419-5 LOCTITE TO THREADS OF ITEM 180.
- CRIMP HEIGHT REFERENCE SETTING WAS THE SETTING USED WHEN THE APPLICATOR WAS QUALIFIED AT THE FACTORY. ADJUSTMENT MAY BE NECESSARY WHEN RUNNING APPLICATOR IN THE FIELD.
- TERMINAL LUBRICANT IS RECOMMENDED.
- 6. UNLESS SPECIFIED OTHERWISE TORQUE VALUES SHALL BE USED PER DOCUMENT, 101-35000.
- SEE APPROPRIATE APPLICATOR LOG SHEETS FOR APPLIED TERMINALS, WIRE RANGE AND MEMORY CHIP

**\*WARNING**  
ON INSTALLATION, SET WIRE DISC TO CRIMP HEIGHT REFERENCE SETTING FOR LARGEST WIRE SIZE. CRIMP HEIGHT REFERENCE SETTINGS GREATER THAN THE VALUE SHOWN MAY CAUSE DAMAGE TO THE CRIMP TOOLING. REFER TO THE INSTRUCTION SHEET FOR PROPER SETUP AND ADJUSTMENTS.

**ATLANTIC VERSION**  
Shown on sheets 1 of 4 & 2 of 4  
(Pacific version shown on sheets 3 of 4 & 4 of 4)

LOC	DIST	REVISIONS					
A	66	#	LYR	DESCRIPTION	DATE	OWN	APVD
		B2		ECR-17-004351	28MAR2017	RS	LZ
		B3		ECR-18-001282	26JAN2018	MZ	GB
		C		ECR-18-013550	25AUG2018	TB	TE
		D		ECR-21-003825	30MAR2021	FJ	TE

-	-	-	-	1	1	-	-	1803515-3	RAM ASSEMBLY, SF ATLANTIC	293
-	-	-	-	1	1	-	-	2-1803583-1	APPLICATOR BASIC ASSEMBLY, SF	292
-	-	1	-	1	-	1	-	2119641-1	FEED CAM, AIR FEED	248
-	-	1	1	1	1	1	1	2119082-9	CAM, SNAIL, INSULATION ADJUSTMENT	244
-	-	1	1	1	1	1	1	2079764-1	WASHER, WAVE SPRING, CREST-TO-CREST	243
-	-	1	1	1	1	1	1	2119083-1	RETAINER, INSULATION DIAL	242
-	-	1	1	1	1	1	1	7-18023-7	SCR, SKT HD CAP M3 X 4.0	241
-	-	1	-	1	-	1	-	2119580-1	MECHANICAL FEED ASSEMBLY	239
-	-	1	-	1	-	1	-	2844940-1	AIR FEED MODULE	238
-	-	-	-	1	1	-	-	4-1722335-3	STRIPPER, SIDE FEED	182
-	-	-	-	1	1	-	-	1-5018030-0	NUT, HEX, REG, RoHS, M3.5	181
-	-	-	-	1	1	-	-	1-1752354-9	STANDOFF, HOLD-DOWN	180
-	-	-	-	1	1	-	-	993111-1	PIN, SLOTTED SPRING 3.0 X 20.0	177
-	-	-	-	1	1	-	-	5-22280-0	SPRING, COMPRESSION	176
-	-	-	-	1	1	-	-	1752353-3	GUIDE PIN, HOLDDOWN	175
-	-	-	-	1	1	-	-	1901680-2	GUIDE PIN, HOLDDOWN	174
-	-	REF	REF	REF	REF	REF	REF	994970-2	COUNTER, MAGNETIC	164
-	-	1	1	1	1	1	1	1-18028-2	WASHER, FLAT, REG M4	119
-	-	1	1	1	1	1	1	2119955-1	ASSY, LUBRICATOR, SIDE FEED	113
-	-	1	1	1	1	1	1	2844908-1	SCREW, LOCKING	99
-	-	1	1	1	1	1	1	2844907-1	POST, LOCKING	98
-	-	1	1	1	1	1	1	455888-4	SPACER, CRIMPER	82
1	-	-	-	-	-	-	-	2266115	PRINT, APPLICATOR LOG SHEET	72
-	-	1	1	1	1	1	1	1803607-3	DOCUMENTATION PACKAGE	71
-	-	2	2	2	2	2	2	2119791-9	DEPRESSOR, WIRE	70
-	-	1	1	1	1	1	1	2119740-1	TAG, IDENTIFICATION	67
-	-	2	2	2	2	2	2	2168078-1	SCREW, DRIVE, RH, RoHS, 2 x .188	66
-	-	1	1	1	1	1	1	2168083-2	SCR, SKT HD CAP, RoHS, M4 X 8.0	60
-	-	1	1	1	1	1	1	5-18022-5	SCR, HEX HD CAP, M4 X 6.0	59
-	-	1	1	1	1	1	1	1338685-1	PAWL, FEED	56
-	-	4	4	4	4	4	4	2168083-3	SCR, SKT HD CAP, RoHS, M4 X 12.0	54
-	-	2	2	2	2	2	2	2168083-3	SCR, SKT HD CAP, RoHS, M4 X 12.0	53
-	-	1	1	1	1	1	1	5018030-1	NUT, HEX, REG, RoHS, M3	52
-	-	1	1	1	1	1	1	811242-5	BUMPER, HOLD DOWN	51
-	-	1	1	1	1	1	1	690753-2	SPACER, TONKER	50
-	-	1	2	1	2	1	2	18023-9	SCR, SKT HD CAP M4 X 6.0	49
-	-	1	-	1	-	1	-	2119652-1	FEED CAM, PRE FEED	48
-	-	1	-	1	-	1	-	2119653-1	FEED CAM, POST FEED	47
-	-	1	1	-	-	1	1	1803583-9	APPLICATOR BASIC ASSEMBLY, SF	46
-	-	1	1	-	-	1	1	1803515-1	RAM ASSEMBLY, SF ATLANTIC	44
-	-	1	1	1	1	1	1	1803602-1	SCR, BHSC, RoHS (M8 X 25)	41
-	-	1	1	1	1	1	1	2-1752356-0	SUPPORT, TERMINAL	34
-	-	2	2	2	2	2	2	2079383-5	SCR, BHSC, RoHS (M4 X 20)	33
-	-	2	2	2	2	2	2	2-2844962-8	SPACER, CYLINDRICAL, STRIP GUIDE	30
-	-	1	1	1	1	1	1	2844992-1	ASSEMBLY, STRIP GUIDE	29
-	-	1	1	1	1	1	1	1320928-6	STRIP GUIDE	24
-	-	1	1	-	-	1	1	2168083-2	SCR, SKT HD CAP, RoHS, M4 X 8.0	21
-	-	2	2	1	1	2	2	1-18028-2	WASHER, FLAT, REG M4	20
-	-	1	1	-	-	1	1	2119533-1	STRIPPER, SIDE FEED	19
-	-	1	1	1	1	1	1	2119806-1	INSERT, SHEAR	13
-	-	1	1	1	1	1	1	3-22280-3	SPRING, COMPRESSION	12
-	-	1	1	1	1	1	1	1-356885-4	STOP, SHEAR	11
-	-	1	1	1	1	1	1	2119805-1	SHEAR HOLDER, FRONT	10
-	-	1	1	1	1	1	1	1803095-1	FLOATING SHEAR, FRONT	9
1	1	2	2	1	1	1	1	1-1803293-1	ANVIL, COMBINATION DEUTSCH STYLE	8
-	-	1	1	1	1	1	1	2-240641-8	SPACER	7
-	-	-	-	-	-	-	-	-	-	6
-	-	1	1	1	1	1	1	1-2119757-0	DEPRESSOR, SHEAR	5
-	-	1	1	1	1	1	1	238011-9	BLOCK, CRIMPER SPACER	4
1	1	2	2	1	1	1	1	1803019-6	CRIMPER, INSULATION O	3
-	-	1	1	1	1	1	1	455888-7	SPACER, CRIMPER	2
-	-	1	2	2	1	1	1	4-1633713-2	CRIMPER, WIRE PREMIUM	1

DIMENSIONS:		TOLERANCES UNLESS OTHERWISE SPECIFIED:		OWN	CHK	APVD	DATE	NAME		RESTRICTED TO
mm	0 PLC ±	1 PLC ±	2 PLC ±	R. KNEPPER	G. BAILEY	M. CLIFFORD	15-Oct-13	Ocean Side Feed Applicator		
	3 PLC ±	4 PLC ±	ANGLES FINISH *					Customer Accessible Production Drawing		
MATERIAL								SIZE	CAGE CODE	DRAWING NO
								A1	00779	©=2266115
								SCALE	SHEET	REV
								1:2	1 of 4	D

LOC	DIST	REVISIONS			
A	66	REV	DATE	OWN	APVD
-	-	SEE SHEET 1	-	-	-

# FEED TYPE MECHANICAL

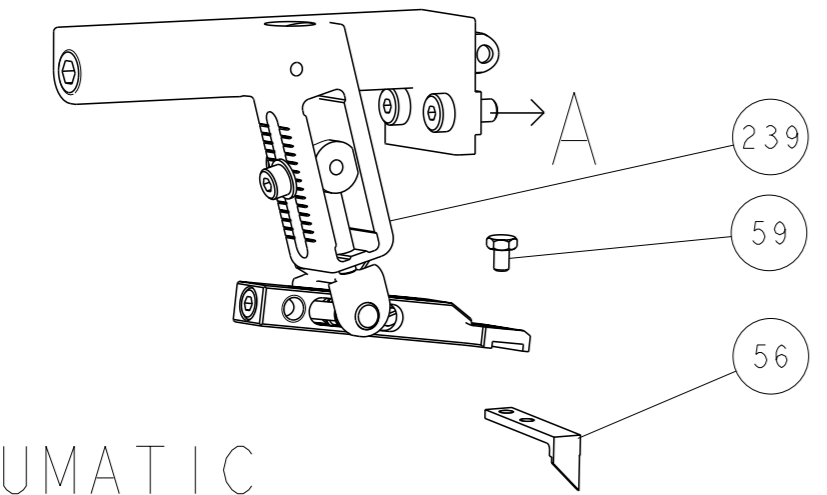

## PNEUMATIC

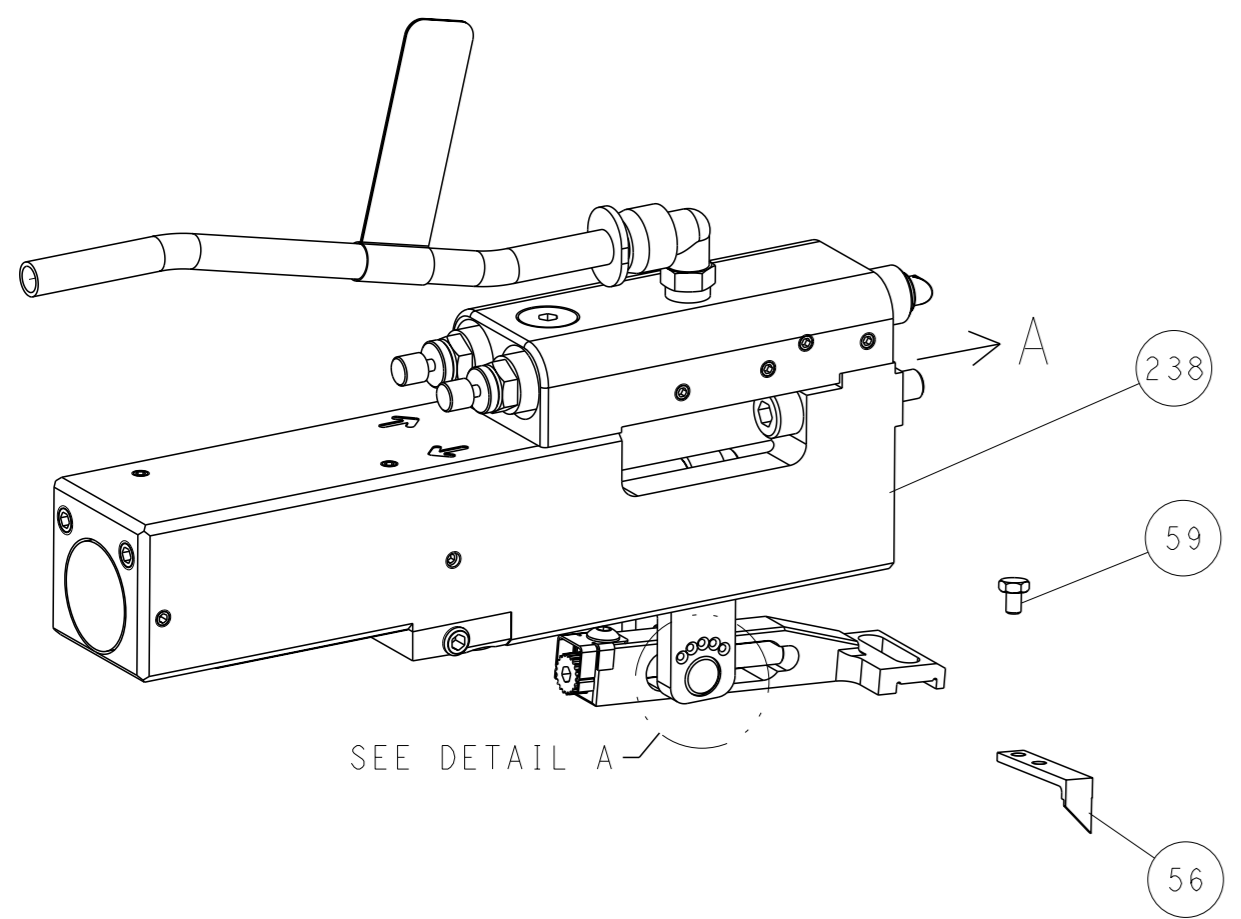

### FEED SPRING SETTING POSITION (SHOWN FROM REAR SIDE)

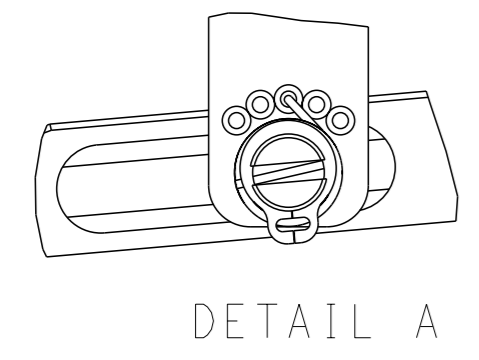

DETAIL A

# CAM POSITIONS

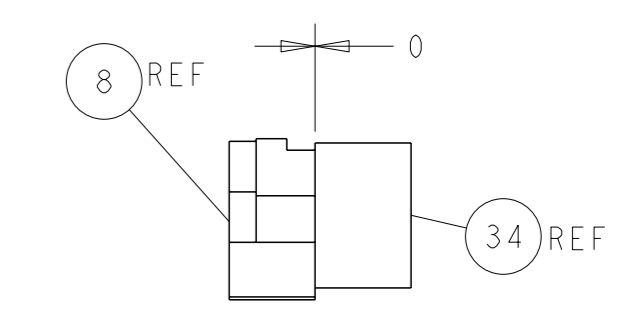
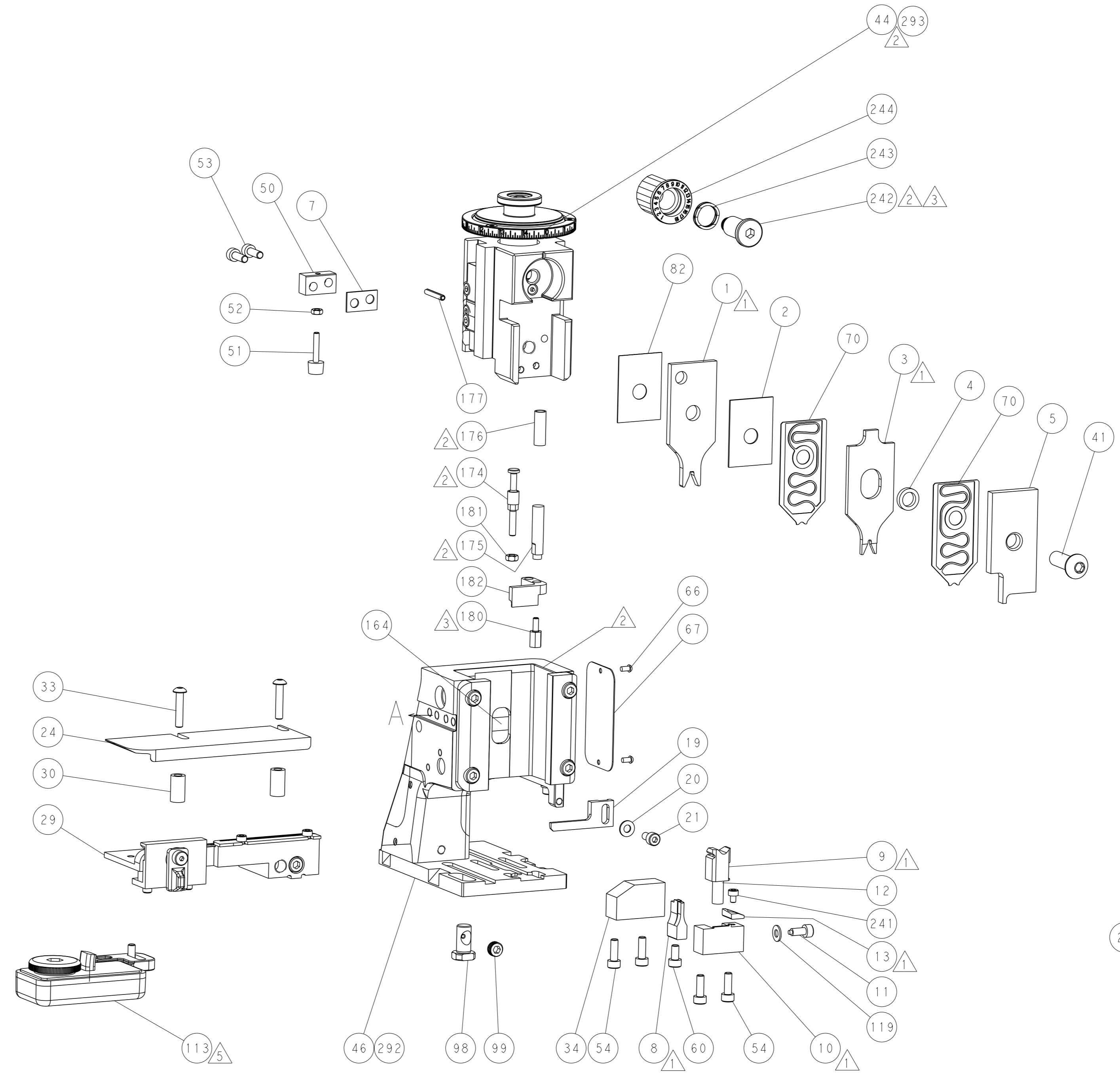
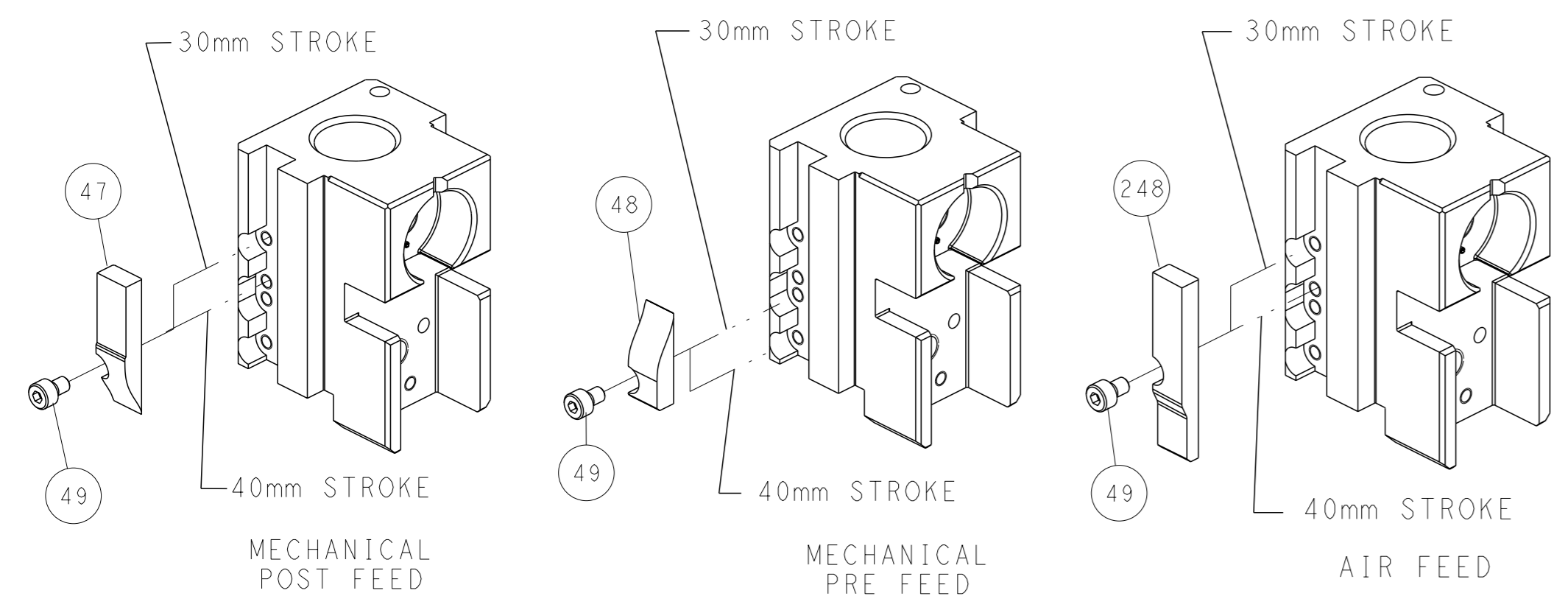

TERMINAL SUPPORT LOCATION

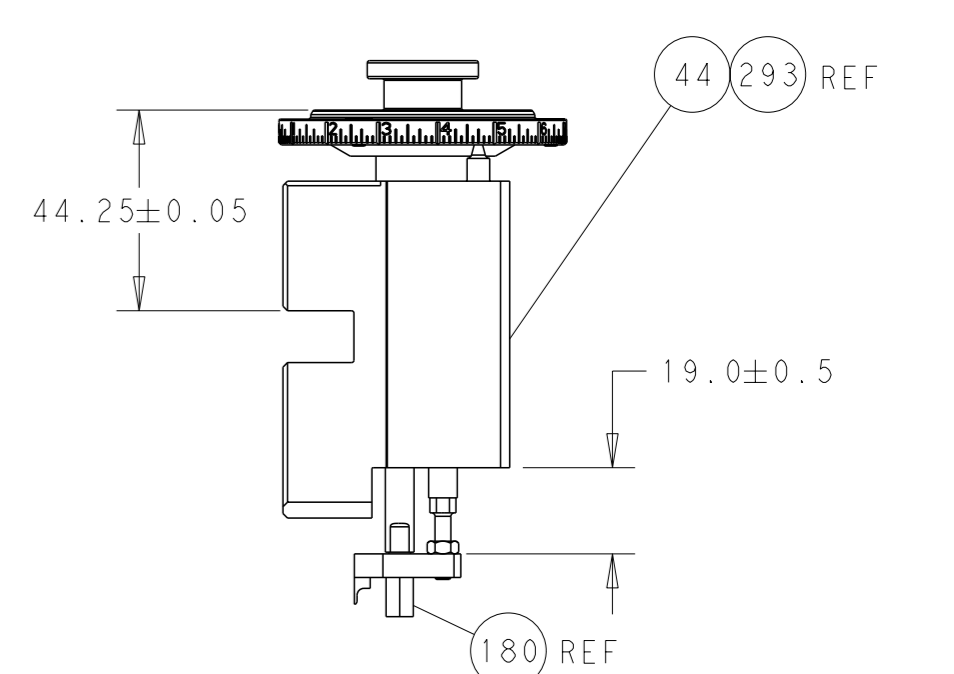

RAM AND HOLDDOWN SET-UP

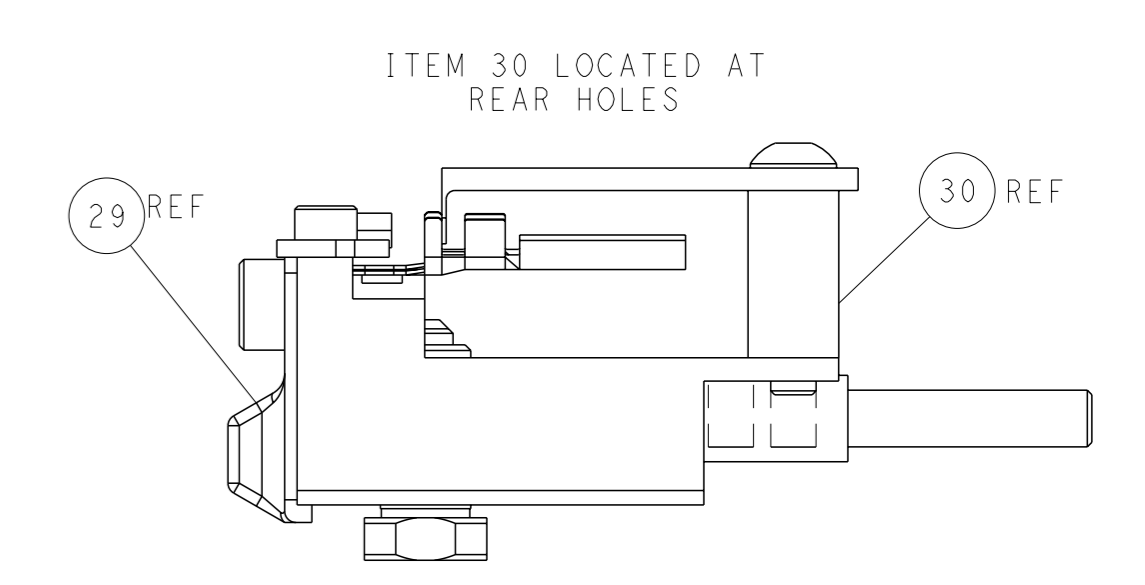

ITEM 30 LOCATED AT REAR HOLES

**ATLANTIC VERSION**  
 Shown on sheets 1 of 4 & 2 of 4  
 (Pacific version shown on sheets 3 of 4 & 4 of 4)

DIMENSIONS: mm 		TOLERANCES UNLESS OTHERWISE SPECIFIED: 0 PLC ± 1 PLC ± 2 PLC ± 3 PLC ± 4 PLC ± ANGLES ± FINISH ±		OWN R. KNEPPER 15-Oct-13 CHK G. BAILEY 15-Oct-13 APVD M. CLIFFORD 15-Oct-13 PRODUCT SPEC APPLICATION SPEC WEIGHT Customer Accessible Production Drawing		NAME Ocean Side Feed Applicator SIZE A1 CAGE CODE 00779 DRAWING NO. C=2266115 SCALE 1:2 SHEET 2 of 4 REV D		TE Connectivity Harrisburg, PA 17105-3608	
-----------------------	--	---	--	---	--	--	--	--	--

PART NUMBER	REVISION	DESCRIPTION	FEED TYPE
2-2266115-1	D	FINE CRIMP HEIGHT ADJUST	MECHANICAL
2-2266115-2	D	FINE CRIMP HEIGHT ADJUST	PNEUMATIC
7-2266115-7	B	CRIMP TOOLING KIT	-
7-2266115-8	B	APPLICATOR CONVERSION KIT	-

PACIFIC VERSION TERMINATOR  
INTERFACE ADAPTER

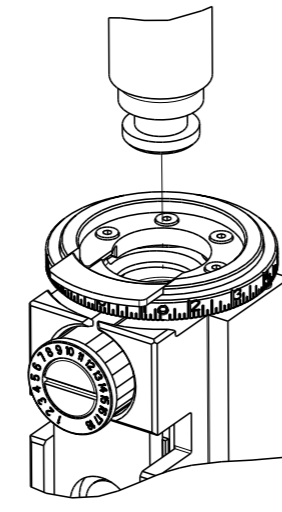

APPLICATOR DATA		
CRIMP	SIZE	TYPE
WIRE	2.62 mm [.103]	F
INSUL	2.03 mm [.080]	O
APPLICATOR INSTRUCTIONS 408-35042		

APPLICATOR CONVERSION KITS	
PART NUMBER	INSULATION DIAMETER RANGE
7-2266112-8	Ø3.15-3.56mm [.124-.140]
7-2266113-8	Ø2.72-3.12mm [.107-.123]
7-2266114-8	Ø2.29-2.69mm [.090-.106]
7-2266115-8	Ø1.91-2.26mm [.075-.089]

TERMINAL DATA: DEUTSCH TERMINAL TE CRIMP SPECIFICATION			
TERMINAL NAME: STAMPED CONTACT PIN SIZE 16			
WIRE STRIP LENGTH	INSULATION DIAMETER RANGE	TE TERMINAL	DEUTSCH TERMINAL
4.44-5.72 mm [.175-.225 IN]	Ø1.91-2.26 mm [.075-.089 IN]	2113238-1	1060-16-1222
TERMINAL APPLICATION SPECIFICATION		2113238-2	1060-16-1244
TERMINALS APPLIED		2113238-3	1060-16-1277

TERMINAL DATA: DEUTSCH TERMINAL TE CRIMP SPECIFICATION			
TERMINAL NAME: STAMPED CONTACT SOCKET SIZE 16			
WIRE STRIP LENGTH	INSULATION DIAMETER RANGE	TE TERMINAL	DEUTSCH TERMINAL
4.44-5.72 mm [.175-.225 IN]	Ø1.91-2.26 mm [.075-.089 IN]	1949119-1	1062-16-1222
TERMINAL APPLICATION SPECIFICATION		1949119-2	1062-16-1244
TERMINALS APPLIED		1949119-3	1062-16-1277
		1949119-4	1062-16-1422
		1949119-5	1062-16-1444
		1949119-6	1062-16-1477

WIRE SIZE	CRIMP HEIGHT mm [INCH]	CRIMP HEIGHT REFERENCE SETTING
14 AWG	1.65+0.03/-0.05 [.065+.001/-0.002]	6.1
2.00mm2	1.63+0.03/-0.05 [.064+.001/-0.002]	6.3
1.50mm2	1.50+0.03/-0.05 [.059+.001/-0.002]	7.6
16 AWG	1.47+0.03/-0.05 [.058+.001/-0.002]	7.9
1.00mm2	1.40+0.03/-0.05 [.055+.001/-0.002]	8.6

**\*WARNING**  
ON INSTALLATION, SET WIRE DISC TO CRIMP HEIGHT REFERENCE SETTING FOR LARGEST WIRE SIZE. CRIMP HEIGHT REFERENCE SETTINGS GREATER THAN THE VALUE SHOWN MAY CAUSE DAMAGE TO THE CRIMP TOOLING. REFER TO THE INSTRUCTION SHEET FOR PROPER SETUP AND ADJUSTMENTS.

- RECOMMENDED SPARE PARTS
- REFER TO SUPPLIED INSTRUCTION SHEET FOR CLEANING, LUBRICATION AND STORAGE OF APPLICATOR.
- APPLY PART NUMBER 2-23419-6 LOCTITE TO THREADS OF ITEM 242.
- CRIMP HEIGHT REFERENCE SETTING WAS THE SETTING USED WHEN THE APPLICATOR WAS QUALIFIED AT THE FACTORY. ADJUSTMENT MAY BE NECESSARY WHEN RUNNING APPLICATOR IN THE FIELD.
- TERMINAL LUBRICANT IS RECOMMENDED.
- UNLESS SPECIFIED OTHERWISE TORQUE VALUES SHALL BE USED PER DOCUMENT, 101-35000.
- SEE APPROPRIATE APPLICATOR LOG SHEETS FOR APPLIED TERMINALS, WIRE RANGE AND MEMORY CHIP

LOC	DIST	REV	DESCRIPTION	DATE	OWN	APVD
A	66	-	SEE SHEET 1	-	-	-

-	-	1	1	2119082-9	CAM, SNAIL, INSULATION ADJUSTMENT	244
-	-	1	1	2079764-1	WASHER, WAVE SPRING, CREST-TO-CREST	243
3	-	1	1	2119083-1	RETAINER, INSULATION DIAL	242
-	-	1	1	7-18023-7	SCR, SKT HD CAP M3 X 4.0	241
-	-	-	1	2119580-1	MECHANICAL FEED ASSEMBLY	239
-	-	1	-	2844940-1	AIR FEED MODULE	238
-	-	REF	REF	994970-2	COUNTER, MAGNETIC	164
-	-	1	-	2119641-2	FEED CAM, AIR FEED	151
-	-	1	1	2168083-8	SCR, SKT HD CAP, RoHS, M4 X 16	144
-	-	4	4	2168083-9	SCR, SKT HD CAP, RoHS, M4 X 20	143
-	-	-	1	2119653-2	FEED CAM, POST FEED	142
-	-	1	1	1-1803583-0	APPLICATOR BASIC ASSEMBLY, SF	141
-	-	1	1	1803516-1	RAM ASSEMBLY, SF PACIFIC	140
-	-	1	1	1-18028-2	WASHER, FLAT, REG M4	119
5	-	1	1	2119955-1	ASSY, LUBRICATOR, SIDE FEED	113
-	-	1	1	2844908-1	SCREW, LOCKING	99
-	-	1	1	2844907-1	POST, LOCKING	98
-	-	1	1	455888-4	SPACER, CRIMPER	82
1	-	-	-	2266115	PRINT, APPLICATOR LOG SHEET	72
-	-	1	1	1803607-3	DOCUMENTATION PACKAGE	71
-	-	2	2	2119791-9	DEPRESSOR, WIRE	70
-	-	1	1	2119740-1	TAG, IDENTIFICATION	67
-	-	2	2	2168078-1	SCREW, DRIVE, RH, RoHS, 2 x .188	66
-	-	1	1	5-18022-5	SCR, HEX HD CAP, M4 X 6.0	59
-	-	1	1	1338685-1	PAWL, FEED	56
-	-	2	2	2168083-3	SCR, SKT HD CAP, RoHS, M4 X 12.0	53
-	-	1	1	5018030-1	NUT, HEX, REG, RoHS, M3	52
-	-	1	1	811242-5	BUMPER, HOLD DOWN	51
-	-	1	1	690753-2	SPACER, TONKER	50
-	-	1	2	18023-9	SCR, SKT HD CAP M4 X 6.0	49
-	-	-	1	2119652-1	FEED CAM, PRE FEED	48
-	-	1	1	1803602-1	SCR, BHSC, RoHS (M8 X 25)	41
-	-	1	1	2-1752356-0	SUPPORT, TERMINAL	34
-	-	2	2	2079383-5	SCR, BHSC, RoHS (M4 X 20)	33
-	-	2	2	2-2844962-8	SPACER, CYLINDRICAL, STRIP GUIDE	30
-	-	1	1	2844992-1	ASSEMBLY, STRIP GUIDE	29
-	-	1	1	1320928-6	STRIP GUIDE	24
-	-	1	1	2168083-2	SCR, SKT HD CAP, RoHS, M4 X 8.0	21
-	-	1	1	1-18028-2	WASHER, FLAT, REG M4	20
-	-	1	1	2119533-1	STRIPPER, SIDE FEED	19
1	-	1	1	2119806-1	INSERT, SHEAR	13
-	-	1	1	3-22280-3	SPRING, COMPRESSION	12
-	-	1	1	1-356885-4	STOP, SHEAR	11
1	-	1	1	2119805-1	SHEAR HOLDER, FRONT	10
1	-	1	1	1803095-1	FLOATING SHEAR, FRONT	9
1	1	1	1	1-1803293-1	ANVIL, COMBINATION DEUTSCH STYLE	8
-	-	1	1	2-240641-8	SPACER	7
-	-	-	-	-	-	6
-	-	1	1	1-2119757-0	DEPRESSOR, SHEAR	5
-	-	1	1	238011-9	BLOCK, CRIMPER SPACER	4
1	1	1	1	1803019-6	CRIMPER, INSULATION O	3
-	-	1	1	455888-7	SPACER, CRIMPER	2
1	-	1	1	4-1633713-2	CRIMPER, WIRE PREMIUM	1
-	-	78	77	22	21	PART NO
-	-	-	-	-	-	DESCRIPTION
-	-	-	-	-	-	ITEM NO

PACIFIC VERSION  
Shown on sheets 3 of 4 & 4 of 4  
(Atlantic version shown on sheets 1 of 4 & 2 of 4)

DIMENSIONS:		TOLERANCES UNLESS OTHERWISE SPECIFIED:		APPLICATOR DATA	
mm	0 PLC ±	1 PLC ±	2 PLC ±	3 PLC ±	4 PLC ±
ANGLES	FINISH		MATERIAL		
WEIGHT		SCALE		SHEET	
Customer Accessible Production Drawing		SCALE 1:2		SHEET 3 of 4	

LOC		DIST		REVISIONS			
A	66	P	LYR	DESCRIPTION	DATE	OWN	APVD
		-		SEE SHEET 1	-	-	-

# FEED TYPE MECHANICAL

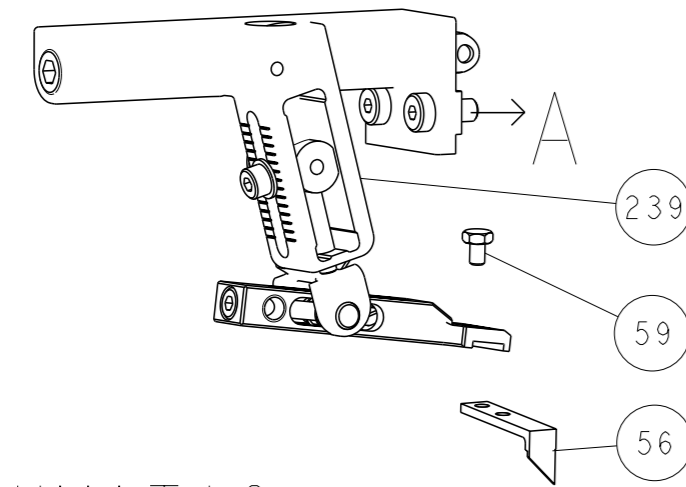

## PNEUMATIC

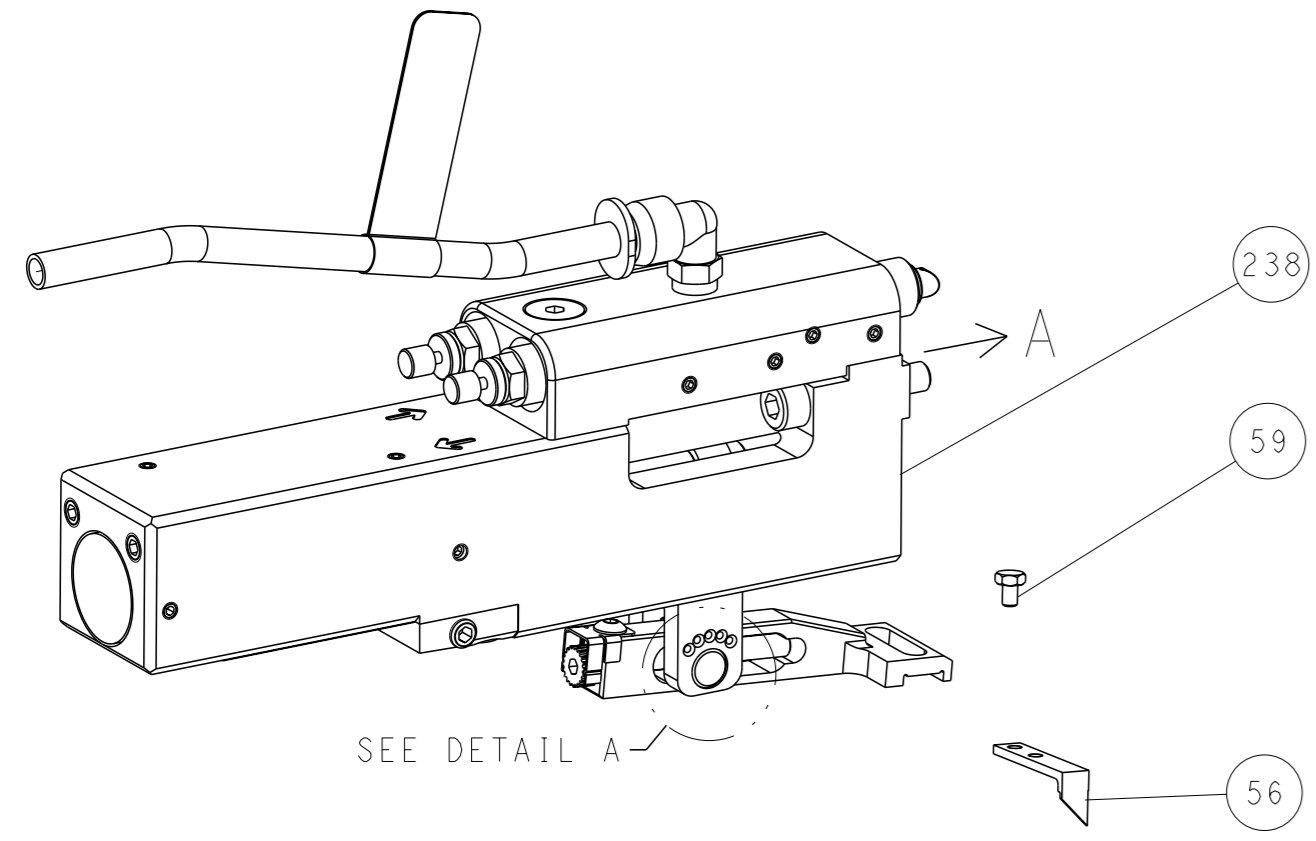

### FEED SPRING SETTING POSITION (SHOWN FROM REAR SIDE)

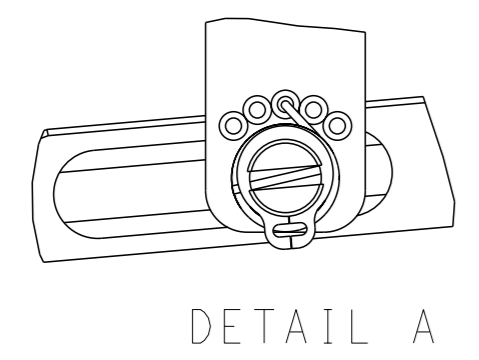

DETAIL A

## CAM POSITIONS

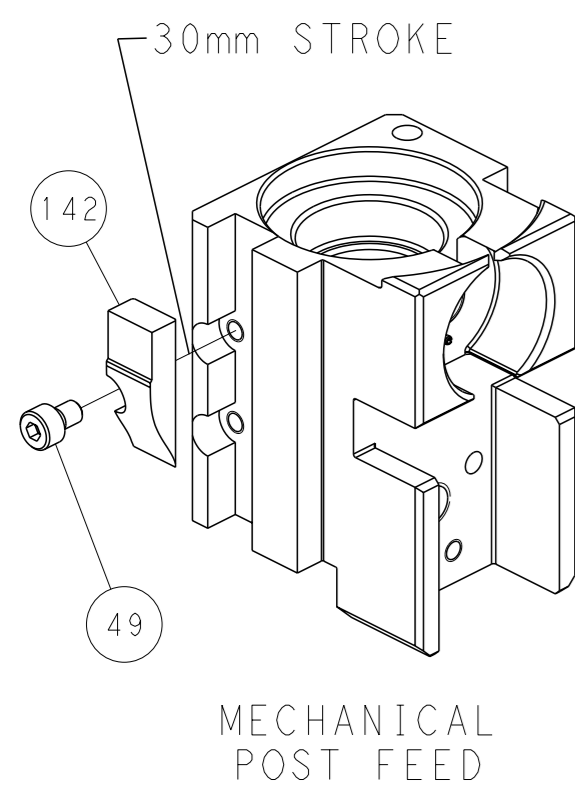

MECHANICAL  
POST FEED

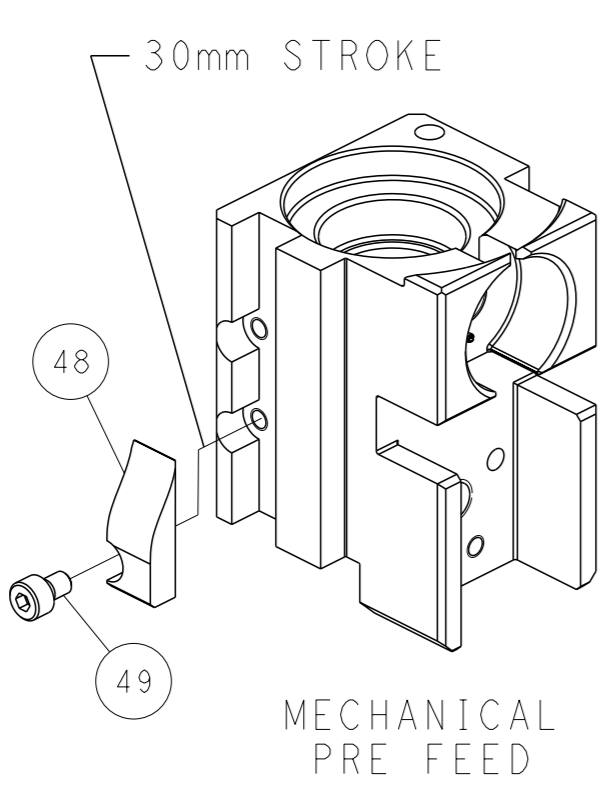

MECHANICAL  
PRE FEED

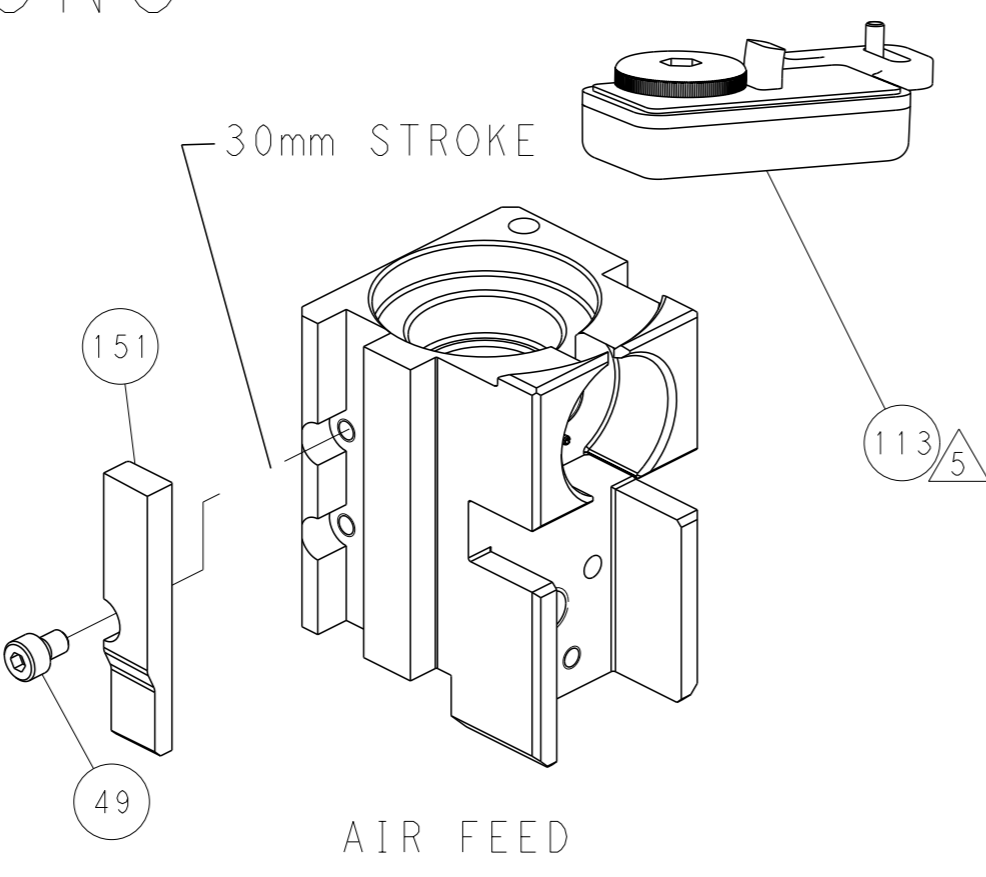

AIR FEED

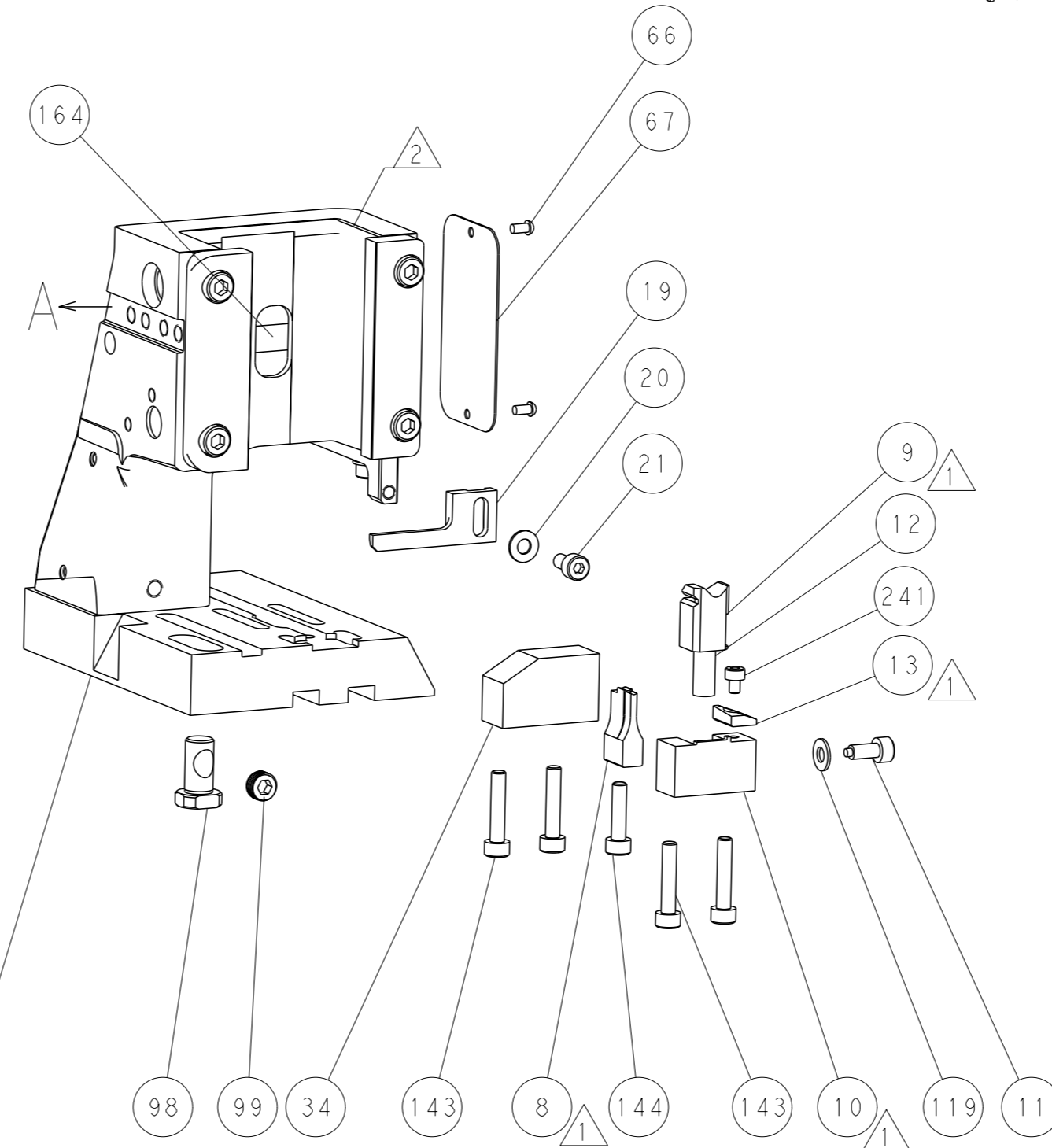
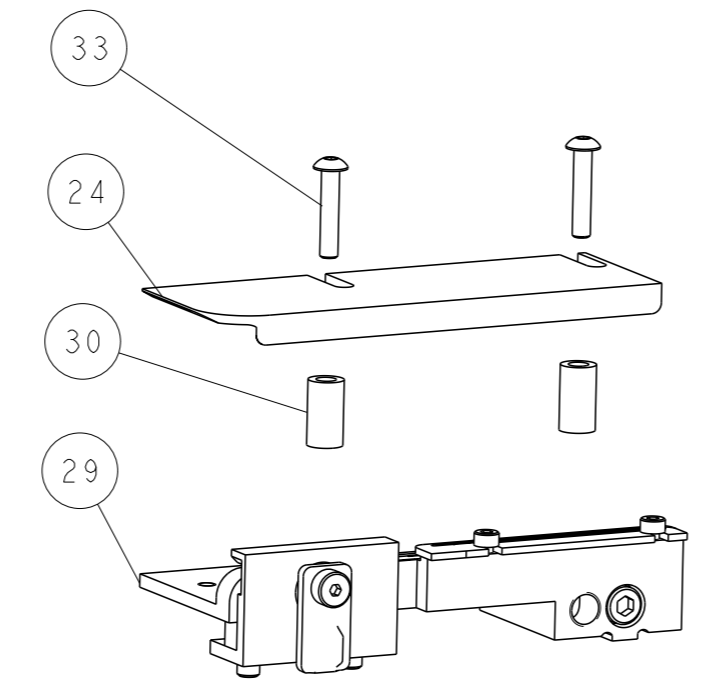

**PACIFIC VERSION**  
 Shown on sheets 3 of 4 & 4 of 4  
 (Atlantic version shown on sheets 1 of 4 & 2 of 4)

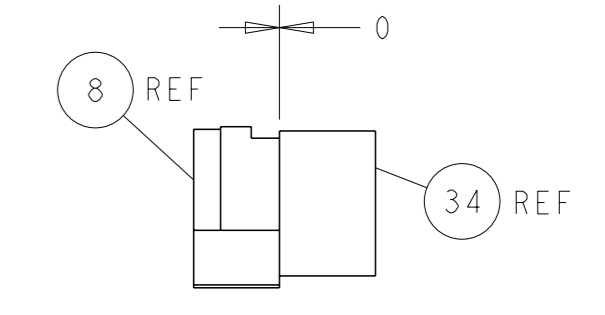

TERMINAL SUPPORT LOCATION

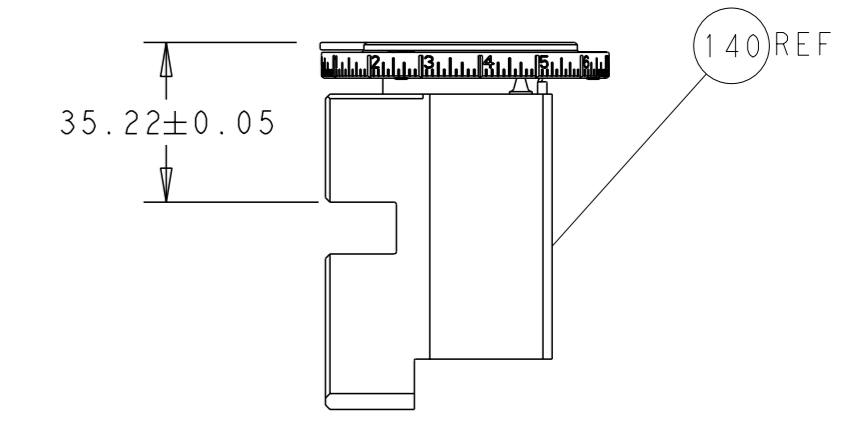

RAM SET-UP

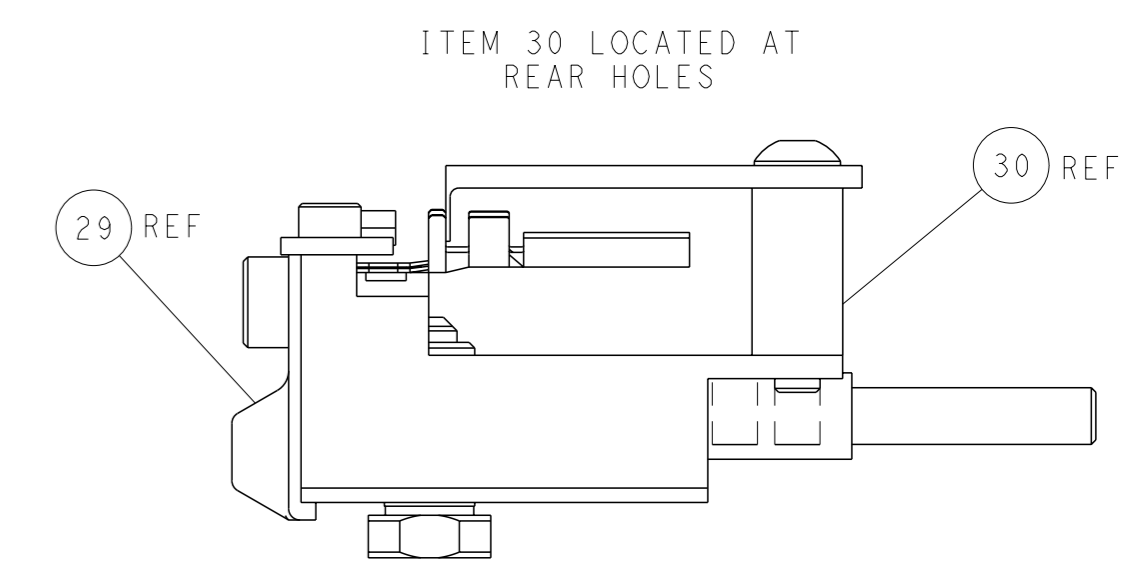

FEED TRACK POSITION  
GUIDE BY INSULATION BARREL

<small>THIS DRAWING IS A CONTROLLED DOCUMENT FOR TYCO ELECTRONICS CORPORATION. IT IS SUBJECT TO CHANGE AND THE USER'S RESPONSIBILITY TO OBTAIN THE LATEST REVISION SHOULD BE CONTACTED FOR THE LATEST REVISION.</small>		DWN R. KNEPPER 15-Oct-13 CHK G. BAILEY 15-Oct-13 APVD M. CLIFFORD 15-Oct-13	TE Connectivity Harrisburg, PA 17105-3608
DIMENSIONS: mm TOLERANCES UNLESS OTHERWISE SPECIFIED: 0 PLC ± 1 PLC ± 2 PLC ± 3 PLC ± 4 PLC ± ANGLES FINISH ±		NAME Ocean Side Feed Applicator APPLICATION SPEC SIZE CAGE CODE DRAWING NO. A1 00779 C=2266115 WEIGHT Customer Accessible Production Drawing	RESTRICTED TO SCALE 1:2 SHEET 4 OF 4 REV D