

PART NUMBER	REVISION	DESCRIPTION	FEED TYPE
2266673-1	L	FINE CRIMP HEIGHT ADJUST	MECHANICAL
2266673-2	L	FINE CRIMP HEIGHT ADJUST	PNEUMATIC
3-2266673-2	L	FINE CRIMP HEIGHT ADJUST	DOUBLE ACTING PNEUMATIC WITH SENSORS
7-2266673-1	L	MECHANICAL AND CRIMP TOOLING KIT	MECHANICAL
7-2266673-2	L	PNEUMATIC AND CRIMP TOOLING KIT	PNEUMATIC
7-2266673-7	F	CRIMP TOOLING KIT	-

ATLANTIC VERSION TERMINATOR INTERFACE ADAPTER

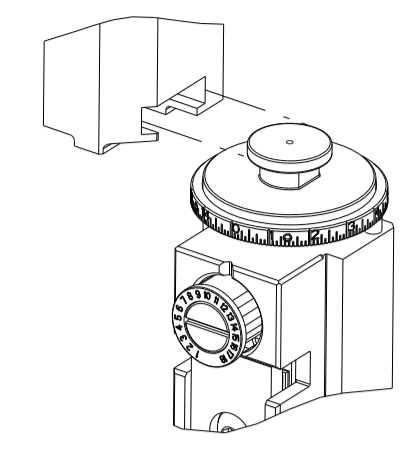

APPLICATOR DATA		
CRIMP	SIZE	TYPE
WIRE	1.07 mm [.042]	F
INSUL	1.55 mm [1.061]	O

APPLICATOR INSTRUCTIONS 408-35042

TERMINAL DATA: TE TERMINAL TE CRIMP SPECIFICATION			
TERMINAL NAME: CONTACT, MALE/FEMALE, GENERATION Y, 0.64			
WIRE STRIP LENGTH		INSULATION DIAMETER RANGE	
4.00-4.50 mm [1.57-.177 IN]		Ø1.10-1.40 mm [1.043-.055 IN]	
TERMINAL APPLICATION SPECIFICATION		114-13183	
TERMINALS APPLIED			
TE TERMINAL	TE TERMINAL	TE TERMINAL	TE TERMINAL
1924968-8	1-2035334-8	1-1456574-8	1-2138699-4
1924955-8	1-1924727-4	2098762-4	1-2138699-8
1-1924955-8	2035170-4	1456968-8	1-2098753-4
1-1456841-8	1-2035170-4	1-1456968-8	2203242-4
2035334-8	1924275-8		

WIRE SIZE	CRIMP HEIGHT mm [INCH]	CRIMP HEIGHT REFERENCE SETTING
0.35mm2 OR 22 AWG	0.91+/-0.03 [0.036+/-0.001]	8.8

- RECOMMENDED SPARE PARTS
- REFER TO SUPPLIED INSTRUCTION SHEET FOR CLEANING, LUBRICATION AND STORAGE OF APPLICATOR.
- APPLY PART NUMBER 2-23419-6 LOCTITE TO THREADS OF ITEM 242.
- CRIMP HEIGHT REFERENCE SETTING WAS THE SETTING USED WHEN THE APPLICATOR WAS QUALIFIED AT THE FACTORY. ADJUSTMENT MAY BE NECESSARY WHEN RUNNING APPLICATOR IN THE FIELD.
- TERMINAL LUBRICANT IS RECOMMENDED.
- UNLESS SPECIFIED OTHERWISE TORQUE VALUES SHALL BE USED PER DOCUMENT, 101-35000.
- THIS APPLICATOR HAS BEEN DESIGNED TO APPLY WIRES WITH THIN WALL (FLR) INSULATION.
- DIMENSION 1.0±0.5 ON TERMINAL SUPPORT VIEW APPLIES TO ALL SOCKET TERMINALS.
- DIMENSION 4.2±0.5 ON TERMINAL SUPPORT VIEW APPLIES TO ALL PIN TERMINALS.
- THIS APPLICATOR IS EQUIPPED WITH THE DOUBLE ACTING PNEUMATIC FEED WITH SENSORS, AND IS APPLICATION SPECIFIC AND DOES NOT REQUIRE ITEMS 49 & 248.

**\*WARNING**  
 ON INSTALLATION, SET WIRE DISC TO CRIMP HEIGHT REFERENCE SETTING FOR LARGEST WIRE SIZE. CRIMP HEIGHT REFERENCE SETTINGS GREATER THAN THE VALUE SHOWN MAY CAUSE DAMAGE TO THE CRIMP TOOLING. REFER TO THE INSTRUCTION SHEET FOR PROPER SETUP AND ADJUSTMENTS.

LOC		DIST		REVISIONS				
A	66	P	LTN	DESCRIPTION	DATE	OWN	APVD	
		K1		ECR-21-006819	12JUL2021	FJ	YY	
		L		ECR-22-128749	07FEB2022	FZ	TE	
		L1		ECR-22-154414	30SEP2022	JWC	TE	
		L2		ECR-23-167818	01MAR2023	FZ	JAH	

-	1	1	1	1	1	22278-9	SPRING, COMPRESSION	300
-	2	2	2	2	2	4-18032-3	SCR, SET, FLT PNT, M3 X 6.0	299
-	1	1	1	1	1	1803945-4	TONKER	298
-	1	1	1	1	1	1803944-1	SPACER, TONKER	297
-	-	-	1	-	-	2844950-1	AIR FEED MODULE	290
-	1	-	-	1	-	2119641-1	FEED CAM, AIR FEED	248
-	1	1	1	1	1	2119082-5	CAM, SNAIL, INSULATION ADJUSTMENT	244
-	1	1	1	1	1	2079764-1	WASHER, WAVE SPRING, CREST-TO-CREST	243
-	1	1	1	1	1	2119083-1	RETAINER, INSULATION DIAL	242
-	1	1	1	1	1	7-18023-7	SCR, SKT HD CAP M3 X 4.0	241
-	-	1	-	-	1	2119580-1	MECHANICAL FEED ASSEMBLY	239
-	1	-	-	1	-	2844940-1	AIR FEED MODULE	238
-	REF	REF	REF	REF	REF	994970-2	COUNTER, MAGNETIC	164
-	1	1	1	1	1	1-18028-2	WASHER, FLAT, REG M4	119
-	1	1	1	1	1	2119955-1	ASSY, LUBRICATOR, SIDE FEED	113
-	1	1	1	1	1	2844908-1	SCREW, LOCKING	99
-	1	1	1	1	1	2844907-1	POST, LOCKING	98
-	1	1	1	1	1	455888-4	SPACER, CRIMPER	82
-	1	1	1	1	1	1803607-3	DOCUMENTATION PACKAGE	71
-	1	1	1	1	1	2119791-9	DEPRESSOR, WIRE	70
-	1	1	1	1	1	2119740-1	TAG IDENTIFICATION	67
-	2	2	2	2	2	2168078-1	SCREW, DRIVE, RH, RoHS, 2 x .188	66
-	1	1	1	1	1	2168083-2	SCR, SKT HD CAP, RoHS, M4 X 8.0	60
-	1	1	1	1	1	5-18022-5	SCR, HEX HD CAP, M4 X 6.0	59
-	1	1	1	1	1	1338685-1	PAWL, FEED	56
-	4	4	4	4	4	2168083-3	SCR, SKT HD CAP, RoHS, M4 X 12.0	54
-	2	2	2	2	2	2168083-3	SCR, SKT HD CAP, RoHS, M4 X 12.0	53
-	1	2	-	1	2	18023-9	SCR, SKT HD CAP M4 X 6.0	49
-	-	1	-	-	1	2119652-1	FEED CAM, PRE FEED	48
-	-	1	-	-	1	2119653-1	FEED CAM, POST FEED	47
-	1	1	1	1	1	1803583-9	APPLICATOR BASIC ASSEMBLY, SF	46
-	1	1	1	1	1	1803515-1	RAM ASSEMBLY, SF ATLANTIC	44
-	1	1	1	1	1	1803602-1	SCR, BHSC, RoHS (M8 X 25)	41
-	1	1	1	1	1	6-1752356-2	SUPPORT, TERMINAL	34
-	2	2	2	2	2	2079383-5	SCR, BHSC, RoHS (M4 X 20)	33
-	2	2	2	2	2	2-2844962-4	SPACER, CYLINDRICAL, STRIP GUIDE	30
-	1	1	1	1	1	2844992-4	ASSEMBLY, STRIP GUIDE	29
-	1	1	1	1	1	240792-1	DRAG, TERMINAL	25
-	1	1	1	1	1	1320928-2	STRIP GUIDE	24
-	1	1	1	1	1	2168083-2	SCR, SKT HD CAP, RoHS, M4 X 8.0	21
-	1	1	1	1	1	1-18028-2	WASHER, FLAT, REG M4	20
-	1	1	1	1	1	2119533-1	STRIPPER, SIDE FEED	19
-	1	1	1	1	1	2119806-1	INSERT, SHEAR	13
-	1	1	1	1	1	3-22280-3	SPRING, COMPRESSION	12
-	1	1	1	1	1	1-356885-4	STOP, SHEAR	11
-	1	1	1	1	1	2119805-1	SHEAR HOLDER, FRONT	10
-	1	1	1	1	1	1803095-6	FLOATING SHEAR, FRONT	9
-	1	2	2	1	1	1-1803058-6	ANVIL, COMBINATION	8
-	-	-	-	-	-	-	-	7
-	-	-	-	-	-	-	-	6
-	1	1	1	1	1	2119757-3	DEPRESSOR, SHEAR	5
-	1	1	1	1	1	3-238011-1	BLOCK, CRIMPER SPACER	4
-	1	2	2	1	1	1-1803019-1	CRIMPER, INSULATION O	3
-	1	1	1	1	1	455888-3	SPACER, CRIMPER	2
-	1	2	2	1	1	8-1633860-6	CRIMPER, WIRE	1

ATLANTIC VERSION  
 Shown on sheets 1 of 4 & 2 of 4  
 (Pacific version shown on sheets 3 of 4 & 4 of 4)

DIMENSIONS: mm 		TOLERANCES UNLESS OTHERWISE SPECIFIED: 0 PLC ± 1 PLC ± 2 PLC ± 3 PLC ± 4 PLC ± ANGLES ± FINISH		DWG: J.HOU 06FEB2015 CHK: L.ZHANG 06FEB2015 APVD: J.GUO 06FEB2015		NAME: Ocean Side Feed Applicator SIZE: A1 CAGE CODE: 00779 DRAWING NO: 2266673 RESTRICTED TO:	
MATERIAL:				WEIGHT:		SCALE: 1:2	
Customer Accessible Production Drawing				SHEET 1 of 4		REV. L2	

LOC	DIST	REVISIONS					
A	66	P	LTN	DESCRIPTION	DATE	OWN	APVD
		-		SEE SHEET 1			

# FEED TYPE MECHANICAL

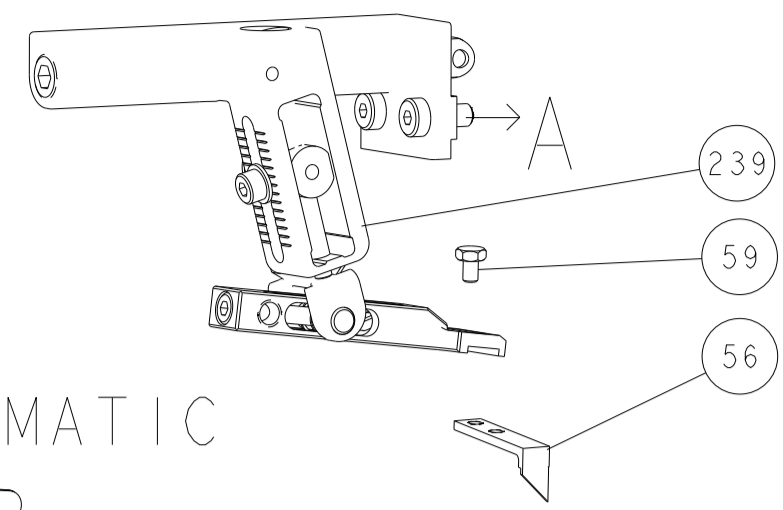

## PNEUMATIC

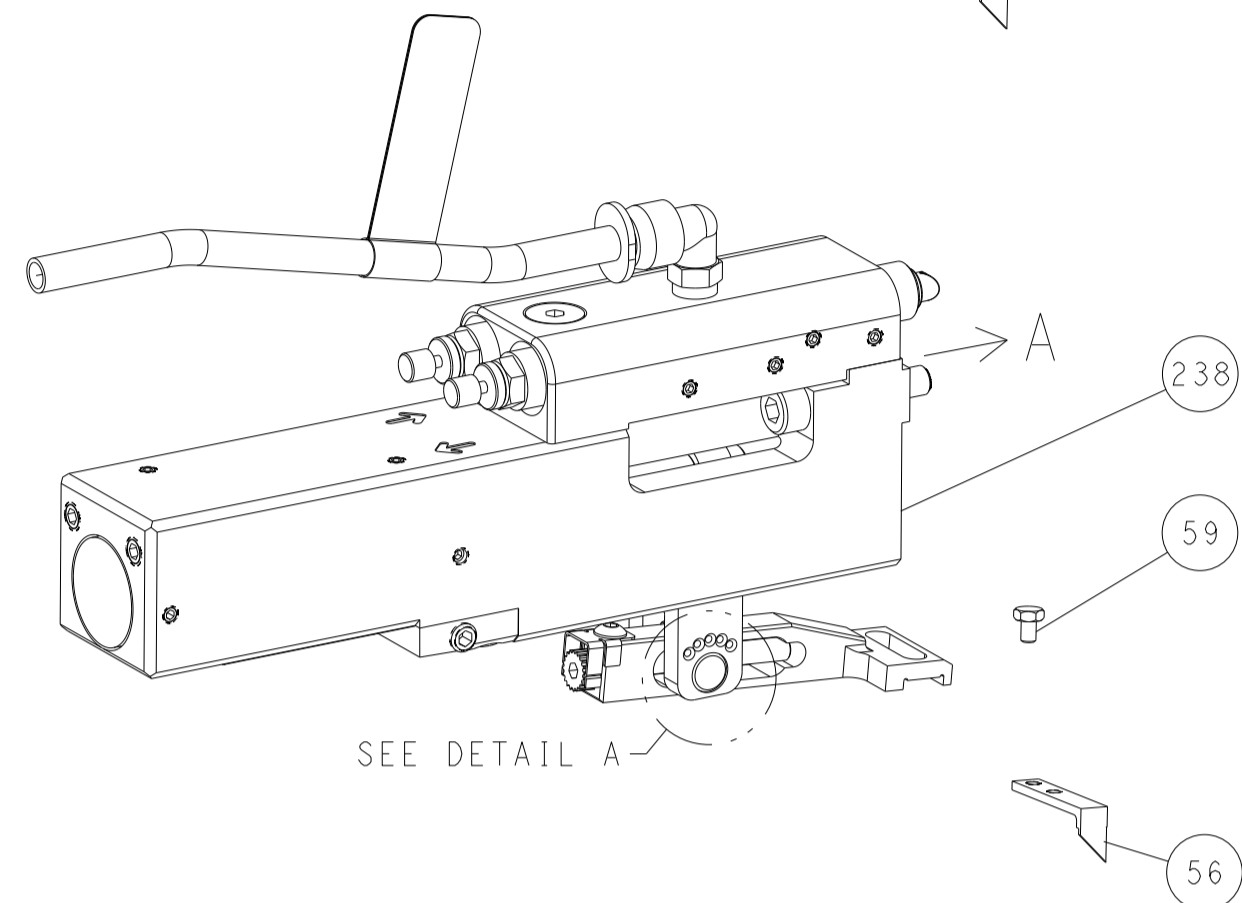

## FEED SPRING SETTING POSITION (SHOWN FROM REAR SIDE)

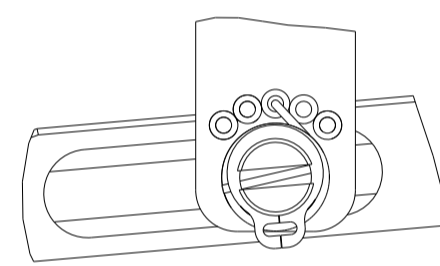

DETAIL A

## DOUBLE ACTING PNEUMATIC WITH SENSORS

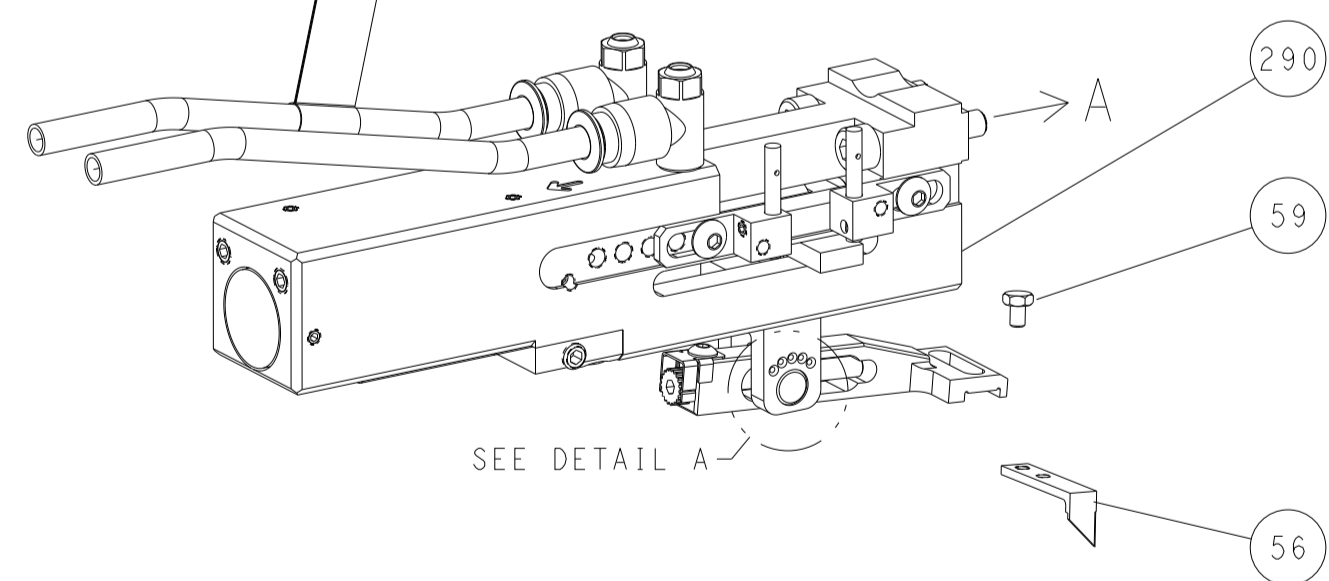

# CAM POSITIONS

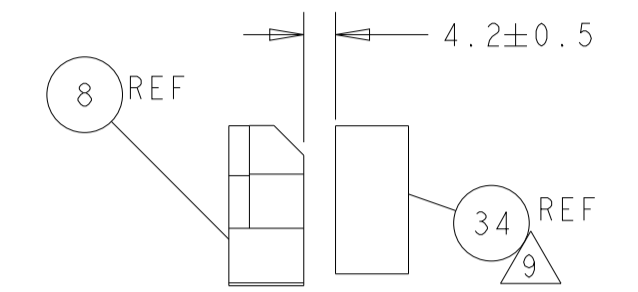
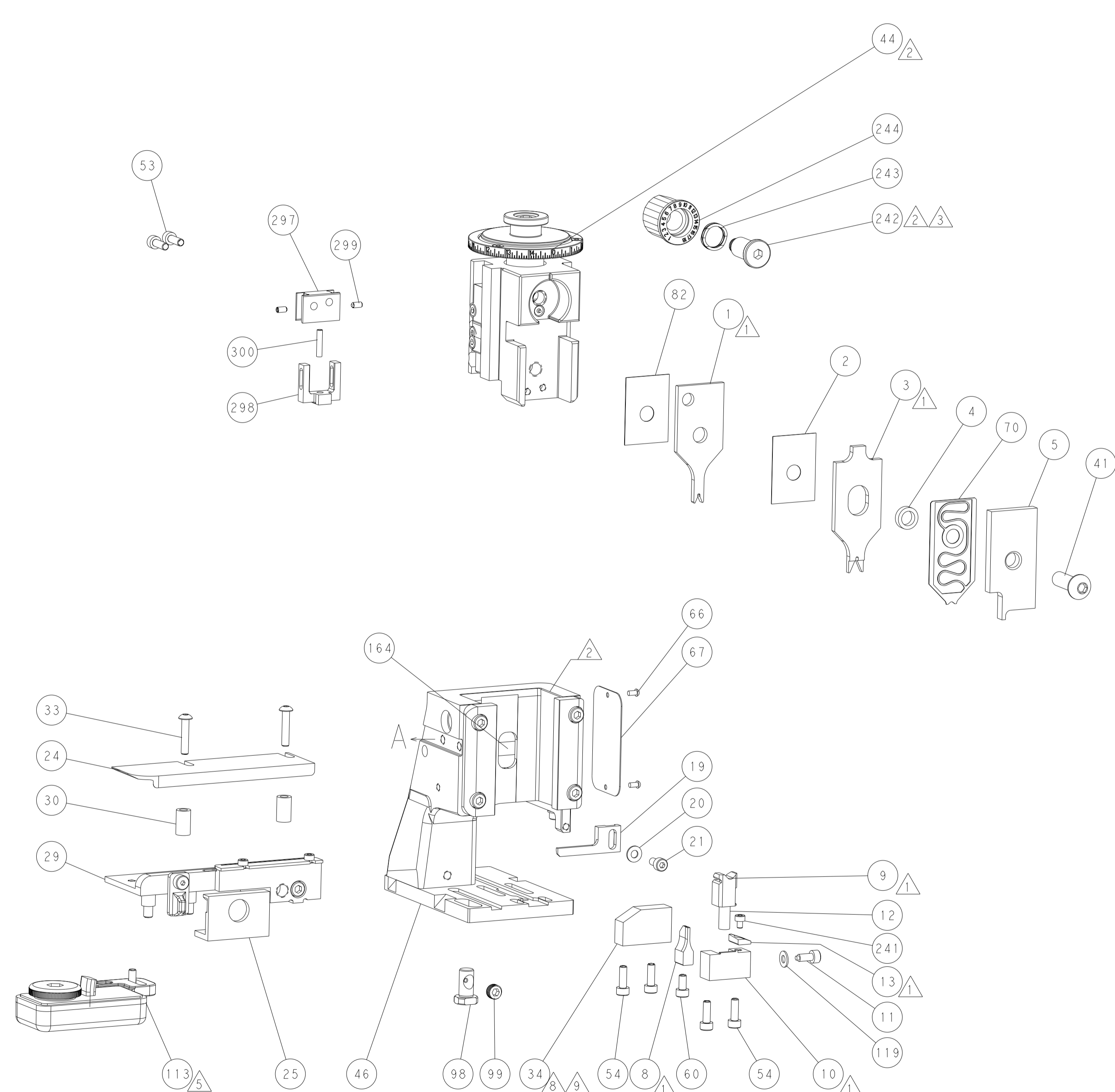
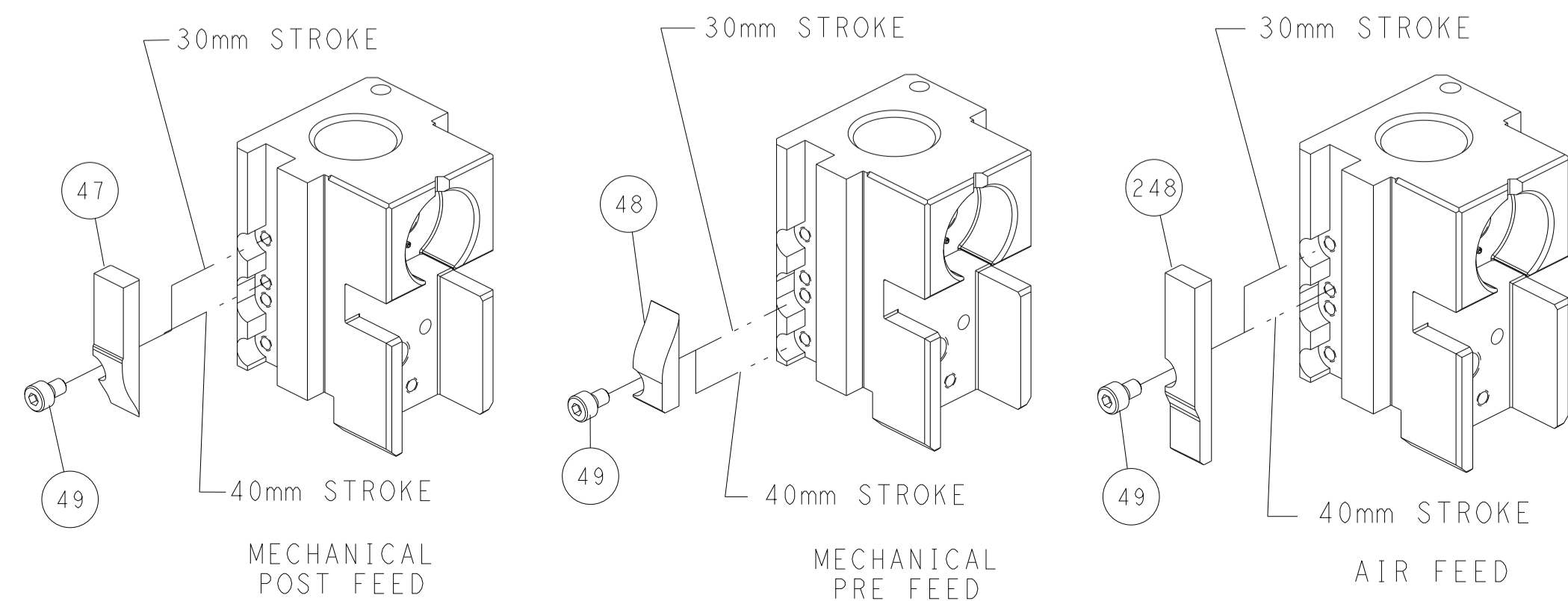

TERMINAL SUPPORT LOCATION FOR ALL PIN TERMINALS

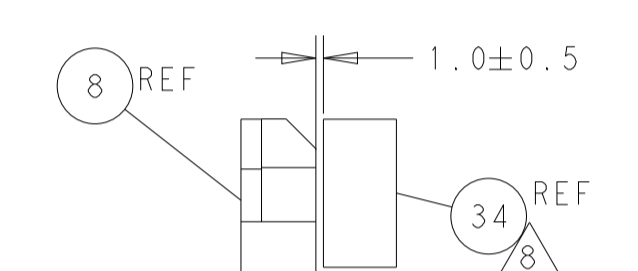

TERMINAL SUPPORT LOCATION FOR ALL SOCKET TERMINALS

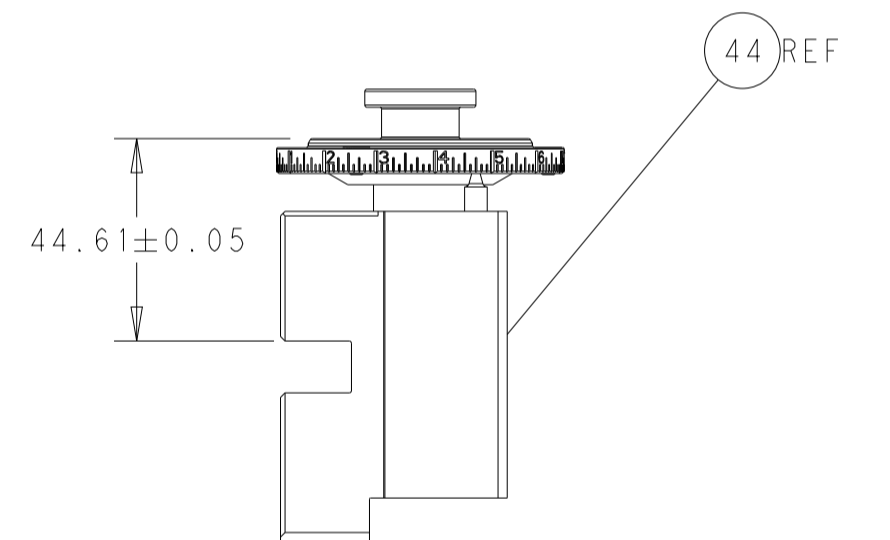

RAM SET-UP

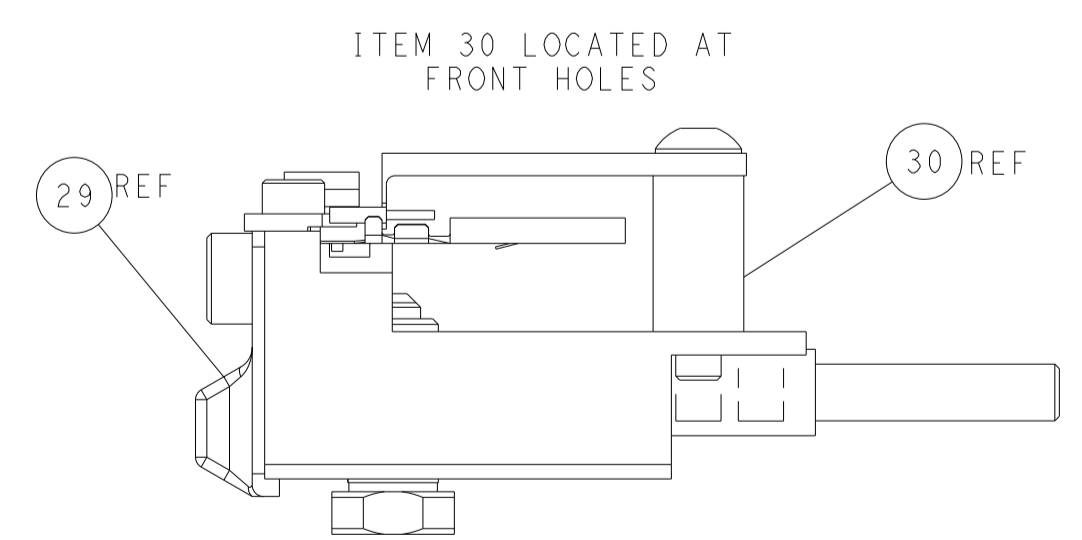

FEED TRACK POSITION GUIDE BY INSULATION BARREL

**ATLANTIC VERSION**  
 Shown on sheets 1 of 4 & 2 of 4  
 (Pacific version shown on sheets 3 of 4 & 4 of 4)

<small>THIS DRAWING IS UNPUBLISHED. RELEASED FOR PUBLICATION. ALL RIGHTS RESERVED. © 2015 BY TYCO ELECTRONICS CORPORATION. THIS DRAWING IS CONTROLLED DOCUMENT. ANY REPRODUCTION OR DISTRIBUTION WITHOUT THE WRITTEN PERMISSION OF TYCO ELECTRONICS CORPORATION IS STRICTLY PROHIBITED.</small>		DWN: J. HOU 06FEB2015 CHK: L. ZHANG 06FEB2015 APVD: J. GUO 06FEB2015	NAME: Ocean Side Feed Applicator SIZE: A1 CAGE CODE: 00779 DRAWING NO: 2266673 SCALE: 1:2 SHEET: 2 OF 4 REV: L2
DIMENSIONS: mm TOLERANCES UNLESS OTHERWISE SPECIFIED: 0 PLC ± 1 PLC ± 2 PLC ± 3 PLC ± 4 PLC ± ANGLES ± FINISH	TOLERANCES UNLESS OTHERWISE SPECIFIED: 0 PLC ± 1 PLC ± 2 PLC ± 3 PLC ± 4 PLC ± ANGLES ± FINISH	WEIGHT: - MATERIAL: - RESTRICTED TO: -	TE Connectivity Harrisburg, PA 17105-3608 Customer Accessible Production Drawing

PART NUMBER	REVISION	DESCRIPTION	FEED TYPE
2-2266673-1	L	FINE CRIMP HEIGHT ADJUST	MECHANICAL
2-2266673-2	L	FINE CRIMP HEIGHT ADJUST	PNEUMATIC
4-2266673-2	L	FINE CRIMP HEIGHT ADJUST	DOUBLE ACTING PNEUMATIC WITH SENSORS
7-2266673-7	F	CRIMP TOOLING KIT	-

PACIFIC VERSION TERMINATOR INTERFACE ADAPTER

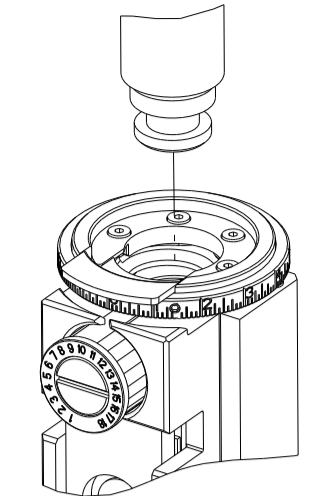

APPLICATOR DATA		
CRIMP	SIZE	TYPE
WIRE	1.07 mm [ .042 ]	F
INSUL	1.55 mm [ .061 ]	O

APPLICATOR INSTRUCTIONS 408-35042

TERMINAL DATA: TE TERMINAL TE CRIMP SPECIFICATION			
TERMINAL NAME: CONTACT, MALE/FEMALE, GENERATION Y, 0.64			
WIRE STRIP LENGTH	INSULATION DIAMETER RANGE		
4.00-4.50 mm [ .157-.177 IN ]	Ø1.10-1.40 mm [ .043-.055 IN ]		
TERMINAL APPLICATION SPECIFICATION	114-13183		
TERMINALS APPLIED			
TE TERMINAL	TE TERMINAL	TE TERMINAL	TE TERMINAL
1924968-8	1-2035334-8	1-1456574-8	1-2138699-4
1924955-8	1-1924727-4	2098762-4	1-2138699-8
1-1924955-8	2035170-4	1456968-8	1-2098753-4
1-1456841-8	1-2035170-4	1-1456968-8	2203242-4
2035334-8	1924275-8		

WIRE SIZE	CRIMP HEIGHT mm [INCH]	CRIMP HEIGHT REFERENCE SETTING
0.35mm2 OR 22 AWG	0.91+/-0.03 [ .036+/- .001 ]	8.8

- 1 RECOMMENDED SPARE PARTS
- 2 REFER TO SUPPLIED INSTRUCTION SHEET FOR CLEANING, LUBRICATION AND STORAGE OF APPLICATOR.
- 3 APPLY PART NUMBER 2-23419-6 LOCTITE TO THREADS OF ITEM 242.
- 4 CRIMP HEIGHT REFERENCE SETTING WAS THE SETTING USED WHEN THE APPLICATOR WAS QUALIFIED AT THE FACTORY. ADJUSTMENT MAY BE NECESSARY WHEN RUNNING APPLICATOR IN THE FIELD.
- 5 TERMINAL LUBRICANT IS RECOMMENDED.
- 6 UNLESS SPECIFIED OTHERWISE TORQUE VALUES SHALL BE USED PER DOCUMENT, 101-35000.
- 7 THIS APPLICATOR HAS BEEN DESIGNED TO APPLY WIRES WITH THIN WALL (FLR) INSULATION.
- 8 DIMENSION 1.0±0.5 ON TERMINAL SUPPORT VIEW APPLIES TO ALL SOCKET TERMINALS.
- 9 DIMENSION 4.2±0.5 ON TERMINAL SUPPORT VIEW APPLIES TO ALL PIN TERMINALS.
- 10 THIS APPLICATOR IS EQUIPPED WITH THE DOUBLE ACTING PNEUMATIC FEED WITH SENSORS, AND IS APPLICATION SPECIFIC AND DOES NOT REQUIRE ITEMS 49 & 151.

ENTRY LEVEL APPLICATOR		ITEM SUBSTITUTION LIST		
PART NUMBER	SAME AS	ITEM	ITEM DESCRIPTION	SUBSTITUTE PART NUMBER
8-2266673-1	2266673-1	1	WIRE CRIMPER	8-1803550-6
8-2266673-2	2266673-2	3	INSULATION CRIMPER	1-1803627-1
9-2266673-1	2-2266673-1	46	BASIC SUB -ASSEMBLY	1803940-9
9-2266673-2	2-2266673-2	141	BASIC SUB -ASSEMBLY	1-1803940-0
			LUBRICATOR	DELETE

**\*WARNING**  
 ON INSTALLATION, SET WIRE DISC TO CRIMP HEIGHT REFERENCE SETTING FOR LARGEST WIRE SIZE. CRIMP HEIGHT REFERENCE SETTINGS GREATER THAN THE VALUE SHOWN MAY CAUSE DAMAGE TO THE CRIMP TOOLING. REFER TO THE INSTRUCTION SHEET FOR PROPER SETUP AND ADJUSTMENTS.

PACIFIC VERSION  
 Shown on sheets 3 of 4 & 4 of 4  
 (Atlantic version shown on sheets 1 of 4 & 2 of 4)

LOC	DIST	REVISIONS					
A	66	P	LTN	DESCRIPTION	DATE	OWN	APVD
		-		SEE SHEET 1			

-	1	1	1	22278-9	SPRING, COMPRESSION	300
-	2	2	2	4-18032-3	SCR, SET, FLT PNT, M3 X 6.0	299
-	1	1	1	1803945-4	TONKER	298
-	1	1	1	1803944-1	SPACER, TONKER	297
-	1	-	-	2844950-1	AIR FEED MODULE	290
-	1	1	1	2119082-5	CAM, SNAIL, INSULATION ADJUSTMENT	244
-	1	1	1	2079764-1	WASHER, WAVE SPRING, CREST-TO-CREST	243
-	1	1	1	2119083-1	RETAINER, INSULATION DIAL	242
-	1	1	1	7-18023-7	SCR, SKT HD CAP M3 X 4.0	241
-	-	-	1	2119580-1	MECHANICAL FEED ASSEMBLY	239
-	-	1	-	2844940-1	AIR FEED MODULE	238
-	REF	REF	REF	994970-2	COUNTER, MAGNETIC	164
-	-	1	-	2119641-2	FEED CAM, AIR FEED	151
-	1	1	1	2168083-8	SCR, SKT HD CAP, RoHS, M4 X 16	144
-	4	4	4	2168083-9	SCR, SKT HD CAP, RoHS, M4 X 20	143
-	-	-	1	2119653-2	FEED CAM, POST FEED	142
-	1	1	1	1-1803583-0	APPLICATOR BASIC ASSEMBLY, SF	141
-	1	1	1	1803516-1	RAM ASSEMBLY, SF PACIFIC	140
-	1	1	1	1-18028-2	WASHER, FLAT, REG M4	119
-	1	1	1	2119955-1	ASSY, LUBRICATOR, SIDE FEED	113
-	1	1	1	2844908-1	SCREW, LOCKING	99
-	1	1	1	2844907-1	POST, LOCKING	98
-	1	1	1	455888-4	SPACER, CRIMPER	82
-	1	1	1	1803607-3	DOCUMENTATION PACKAGE	71
-	1	1	1	2119791-9	DEPRESSOR, WIRE	70
-	1	1	1	2119740-1	TAG, IDENTIFICATION	67
-	2	2	2	2168078-1	SCREW, DRIVE, RH, RoHS, 2 x .188	66
-	1	1	1	5-18022-5	SCR, HEX HD CAP, M4 X 6.0	59
-	1	1	1	1338685-1	PAWL, FEED	56
-	2	2	2	2168083-3	SCR, SKT HD CAP, RoHS, M4 X 12.0	53
-	-	1	2	18023-9	SCR, SKT HD CAP M4 X 6.0	49
-	-	-	1	2119652-1	FEED CAM, PRE FEED	48
-	1	1	1	1803602-1	SCR, BHSC, RoHS (M8 X 25)	41
-	1	1	1	6-1752356-2	SUPPORT, TERMINAL	34
-	2	2	2	2079383-5	SCR, BHSC, RoHS (M4 X 20)	33
-	2	2	2	2-2844962-4	SPACER, CYLINDRICAL, STRIP GUIDE	30
-	1	1	1	2844992-4	ASSEMBLY, STRIP GUIDE	29
-	1	1	1	240792-1	DRAG, TERMINAL	25
-	1	1	1	1320928-2	STRIP GUIDE	24
-	1	1	1	2168083-2	SCR, SKT HD CAP, RoHS, M4 X 8.0	21
-	1	1	1	1-18028-2	WASHER, FLAT, REG M4	20
-	1	1	1	2119533-1	STRIPPER, SIDE FEED	19
-	1	1	1	2119806-1	INSERT, SHEAR	13
-	1	1	1	3-22280-3	SPRING, COMPRESSION	12
-	1	1	1	1-356885-4	STOP, SHEAR	11
-	1	1	1	2119805-1	SHEAR HOLDER, FRONT	10
-	1	1	1	1803095-6	FLOATING SHEAR, FRONT	9
-	1	1	1	1-1803058-6	ANVIL, COMBINATION	8
-	-	-	-	-	-	7
-	-	-	-	-	-	6
-	1	1	1	2119757-3	DEPRESSOR, SHEAR	5
-	1	1	1	3-238011-1	BLOCK, CRIMPER SPACER	4
-	1	1	1	1-1803019-1	CRIMPER, INSULATION O	3
-	1	1	1	455888-3	SPACER, CRIMPER	2
-	1	1	1	8-1633860-6	CRIMPER, WIRE	1

DIMENSIONS:		TOLERANCES UNLESS OTHERWISE SPECIFIED:		DRAWING NO		DESCRIPTION		ITEM NO
mm	0 PLC ±	1 PLC ±	2 PLC ±	3 PLC ±	4 PLC ±	ANGLES ±	FINISH	
MATERIAL				WEIGHT		SCALE		REV
Customer Accessible Production Drawing				SCALE 1:2		SHEET 3 OF 4		REV L2

LOC	DIST	REVISIONS			
A	66	REV	DATE	BY	APPV
-	-	SEE SHEET 1	-	-	-

# FEED TYPE MECHANICAL

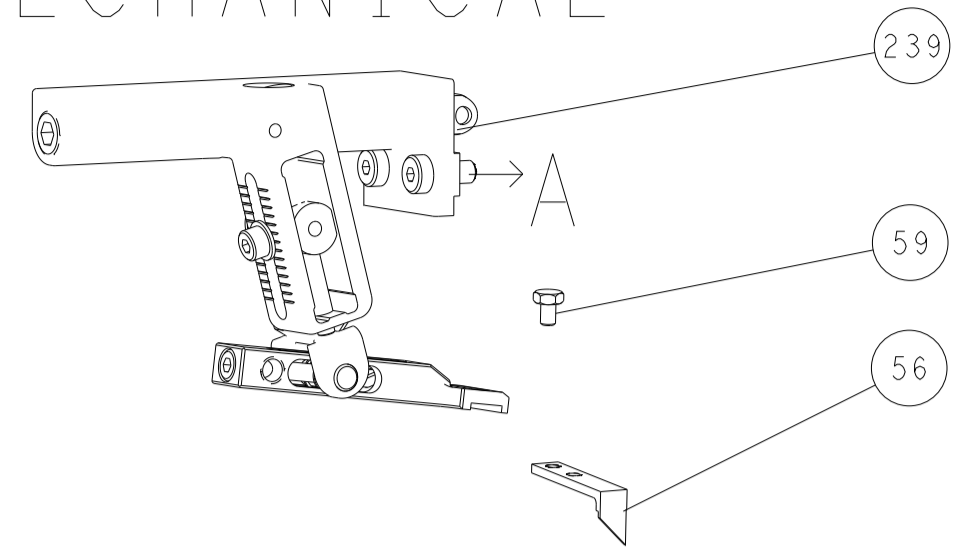

# PNEUMATIC

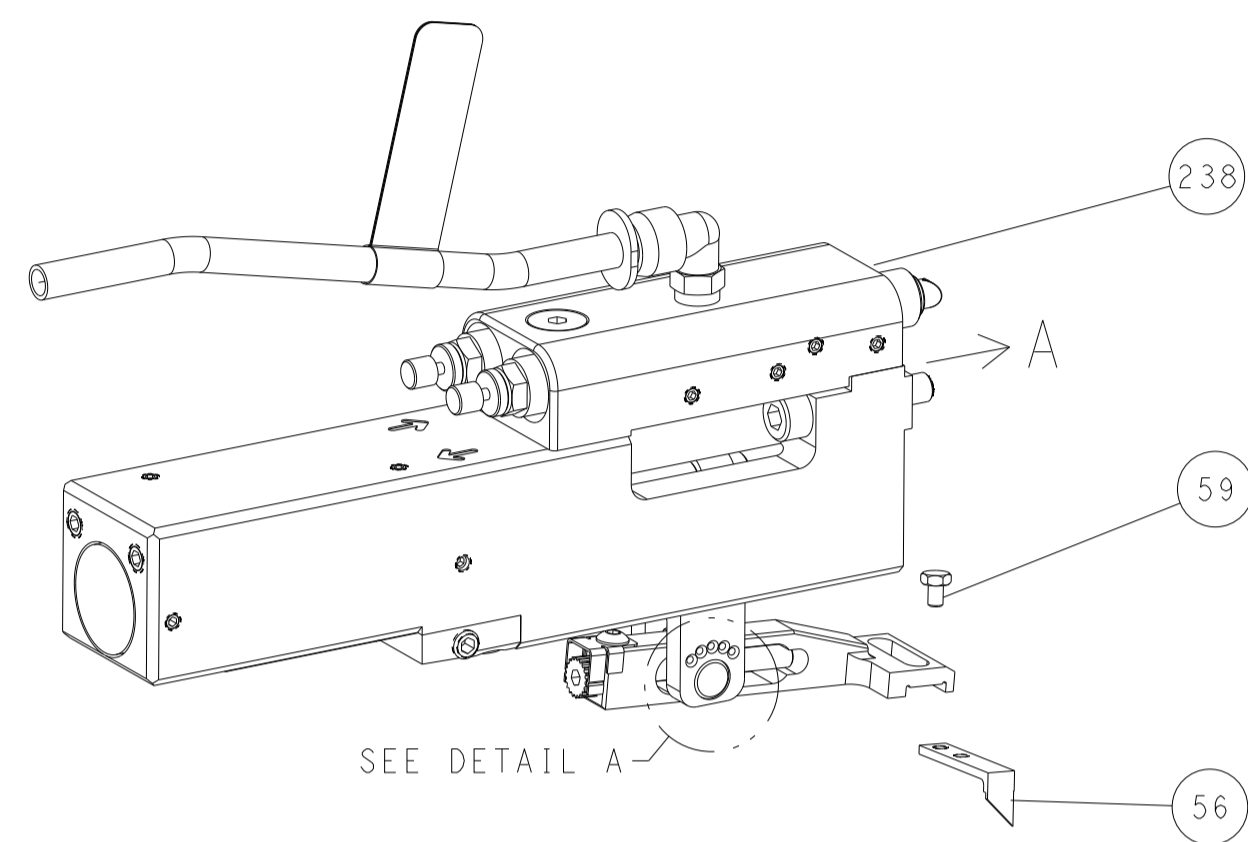

# FEED SPRING SETTING POSITION (SHOWN FROM REAR SIDE)

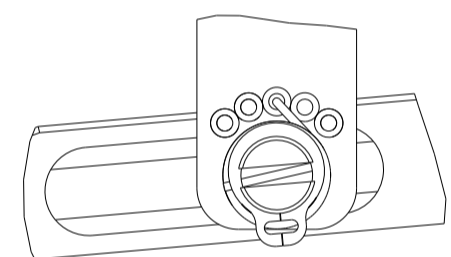

DETAIL A

# DOUBLE ACTING PNEUMATIC WITH SENSORS

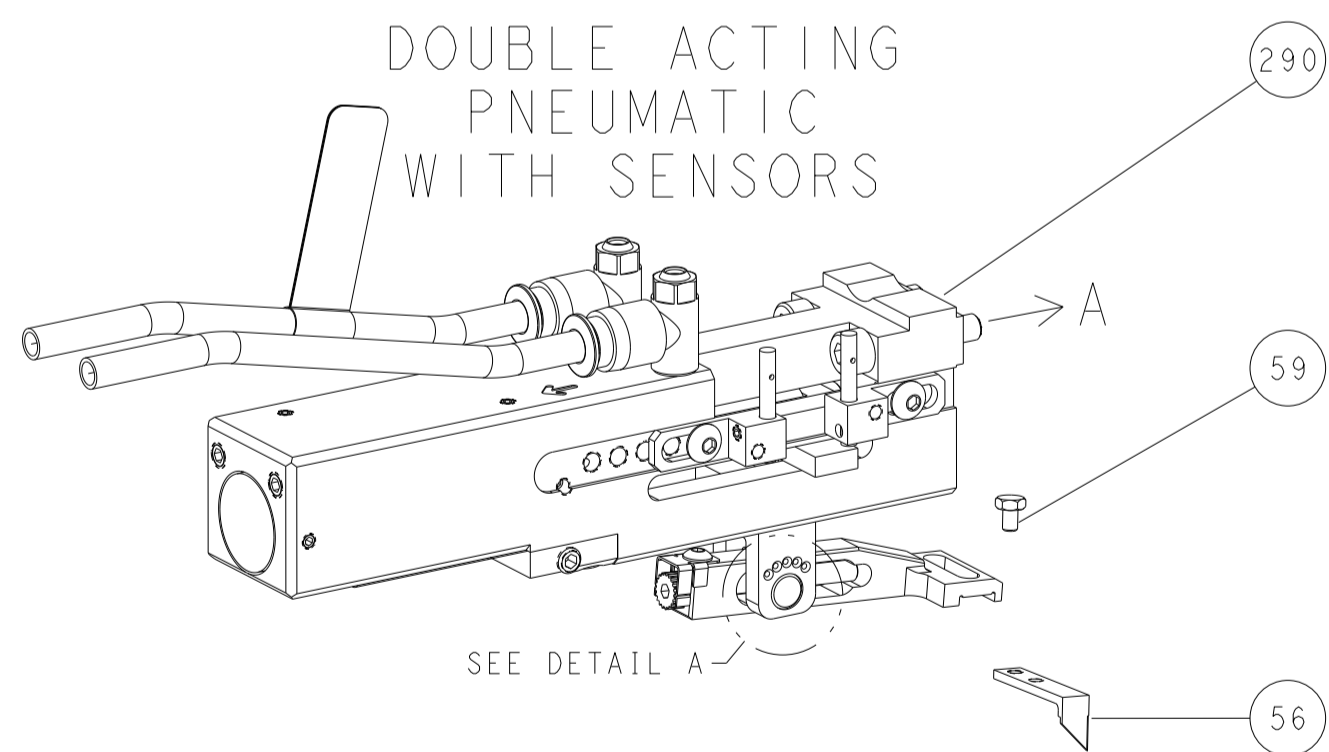

# CAM POSITIONS

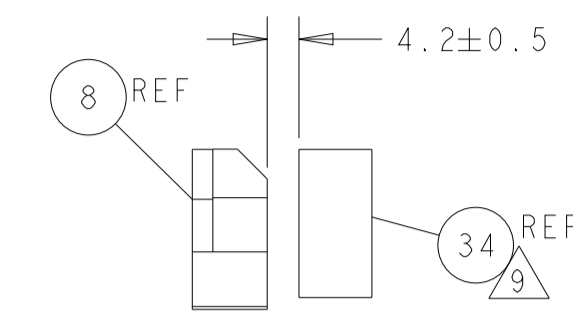
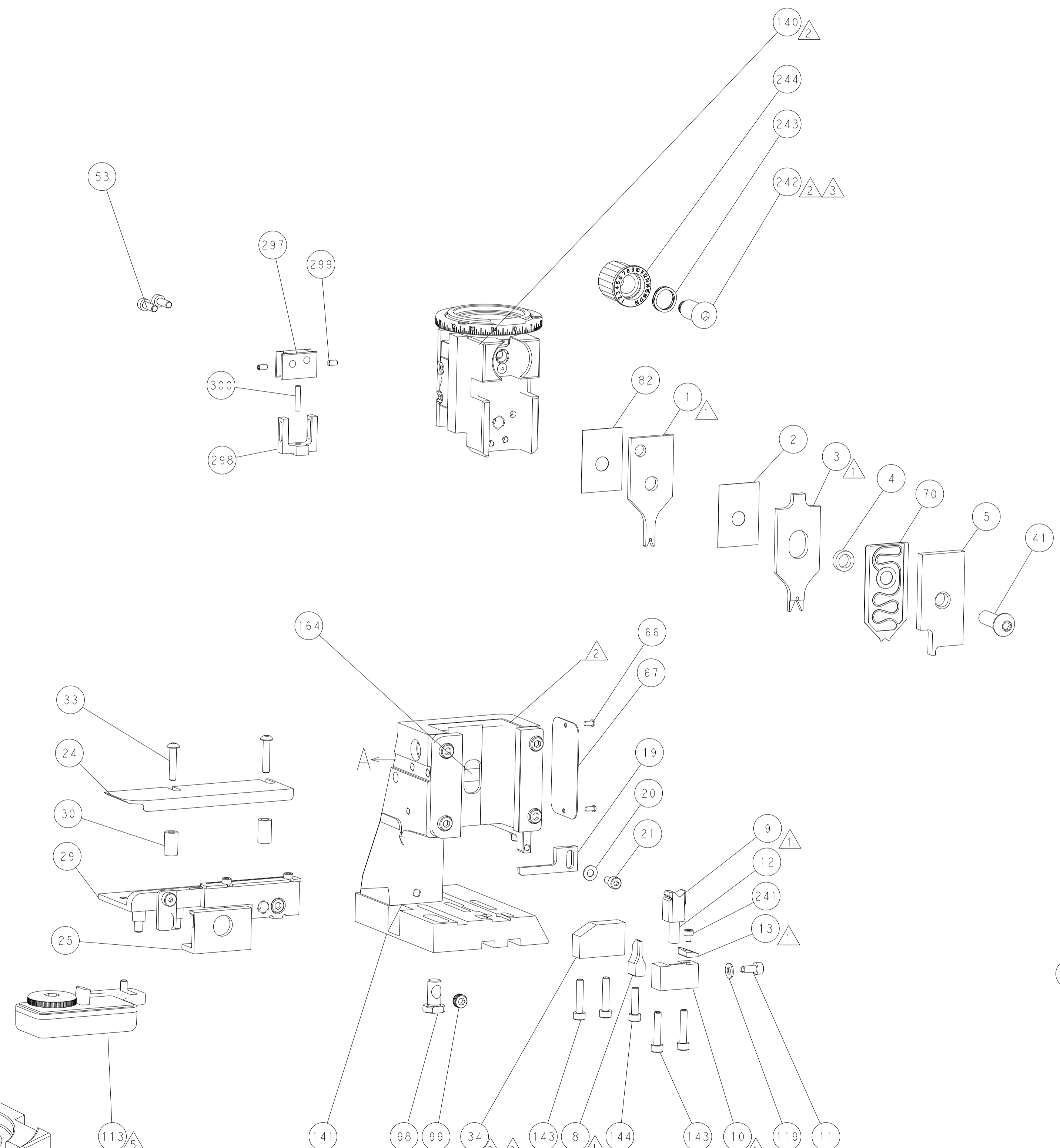
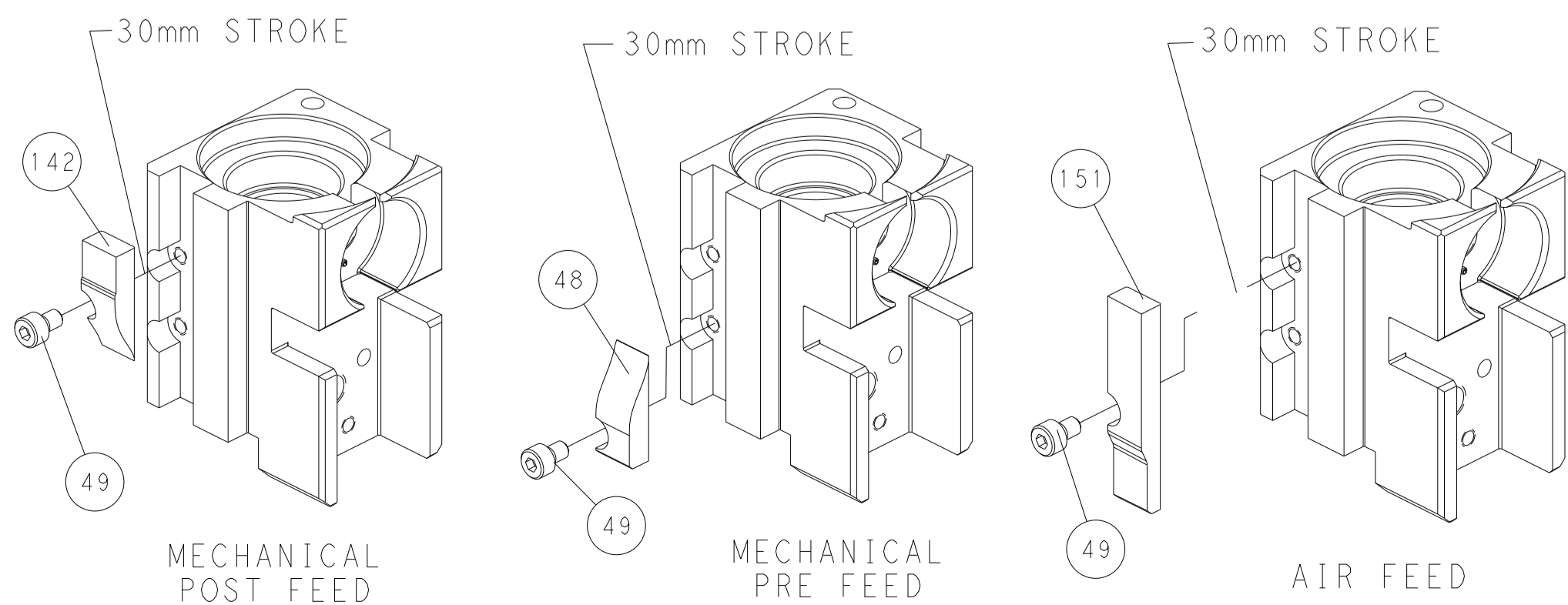

TERMINAL SUPPORT LOCATION FOR ALL PIN TERMINALS

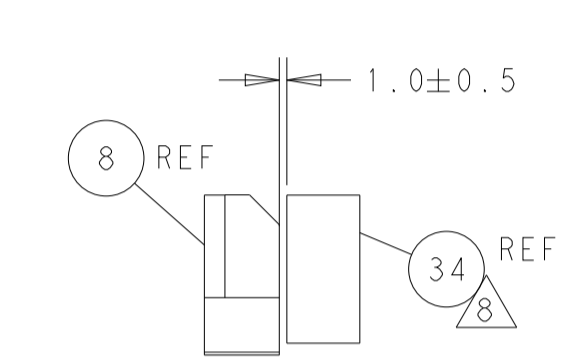

TERMINAL SUPPORT LOCATION FOR ALL SOCKET TERMINALS

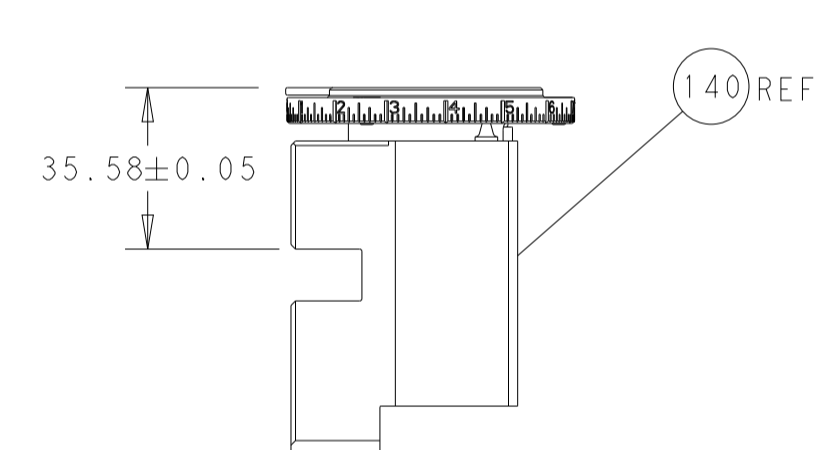

RAM SET-UP

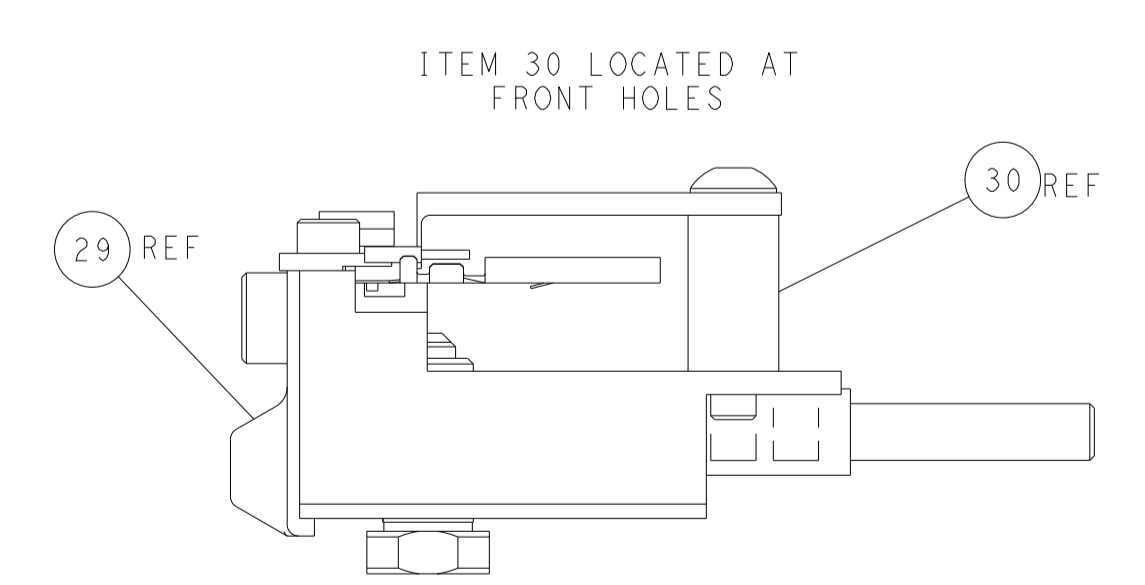

FEED TRACK POSITION GUIDE BY INSULATION BARREL

**PACIFIC VERSION**  
 Shown on sheets 3 of 4 & 4 of 4  
 (Atlantic version shown on sheets 1 of 4 & 2 of 4)

<small>THIS DRAWING IS UNPUBLISHED. RELEASED FOR PUBLICATION. ALL RIGHTS RESERVED. © 2015 BY TYCO ELECTRONICS CORPORATION. THIS DRAWING IS THE PROPERTY OF TYCO ELECTRONICS CORPORATION AND IS NOT TO BE REPRODUCED OR TRANSMITTED IN ANY FORM OR BY ANY MEANS, ELECTRONIC OR MECHANICAL, INCLUDING PHOTOCOPYING, RECORDING, OR BY ANY INFORMATION STORAGE AND RETRIEVAL SYSTEM, WITHOUT THE WRITTEN PERMISSION OF TYCO ELECTRONICS CORPORATION.</small>		DWN: J. HOU 06FEB2015 CHK: L. ZHANG 06FEB2015 APVD: J. GUO 06FEB2015	NAME: TE Connectivity Harrisburg, PA 17105-3608
DIMENSIONS: mm TOLERANCES UNLESS OTHERWISE SPECIFIED: 0 PLC ± 1 PLC ± 2 PLC ± 3 PLC ± 4 PLC ± ANGLES FINISH ±	PRODUCT SPEC APPLICATION SPEC WEIGHT SCALE: 1:2	SIZE: A1 CAGE CODE: 00779 DRAWING NO: C=2266673 SHEET 4 OF 4 REV: L2	RESTRICTED TO: