

THIS DRAWING IS UNPUBLISHED. RELEASED FOR PUBLICATION NOV ,2003.
 © COPYRIGHT 2003 BY TYCO ELECTRONICS CORPORATION. ALL RIGHTS RESERVED.

LOC	DIST	REVISIONS			
P	LTR	DESCRIPTION	DATE	DWN	APVD
E	B	B	EBD0-0248-03	12NOV03	JMS FWK

- ① SINGLE PACK IN ACCORDANCE WITH SPEC 107-3275
- ② 100 TRAY PACK IN ACCORDANCE WITH SPEC 107-3275
- ③ 0.76µm Au PLATING OVER 1.27µm Ni PLATING OVER 0.76µm Cu PLATING
- ④ 0.08µm Au PLATING OVER 1.27µm Ni PLATING OVER 0.76µm Cu PLATING

- 5 HANDTOOL 9-1478240-0
- 6 DIE SET 9-1478248-0

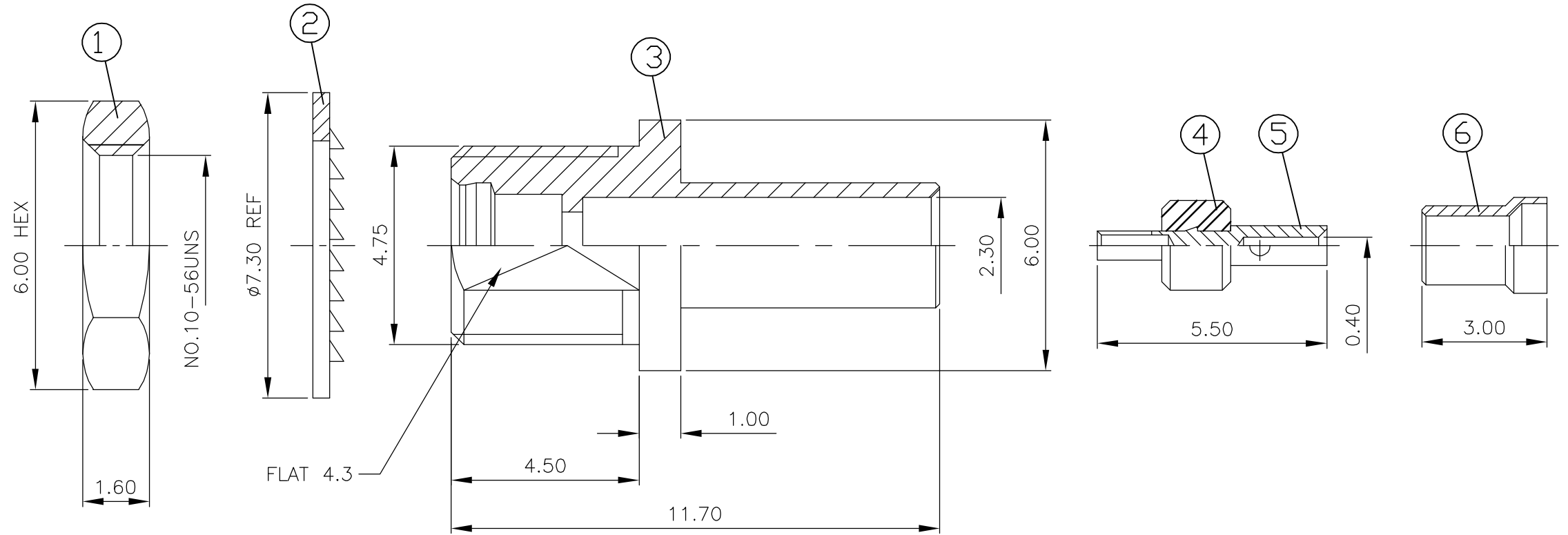

RECOMMENDED CENTRE CONTACT A/F SQR

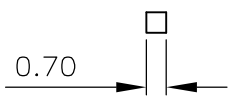

RECOMMENDED CRIMP SLEEVE A/F HEX

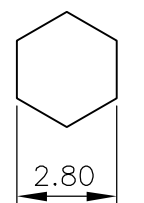

RECOMMENDED CABLE STRIPPING DIM'S

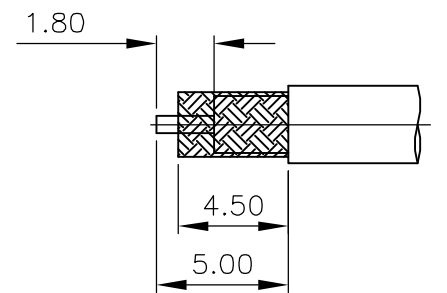

RECOMMENDED MOUNTING HOLE

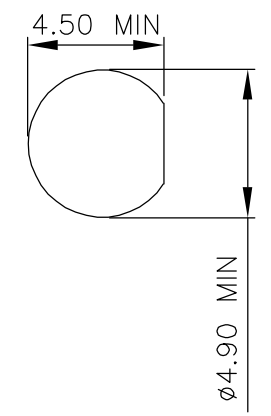

QTY	QTY	MATERIAL	DESCRIPTION	ITEM
1	1	BRASS	④ CRIMP SLEEVE	6
1	1	BERYLLIUM COPPER	③ SOCKET	5
1	1	PTFE	INSULATOR	4
1	1	BRASS	④ BODY	3
1	1	BRASS	④ WASHER	2
1	1	BRASS	④ NUT	1
6--0	1--0	MATERIAL	DESCRIPTION	ITEM
②	①			

THIS DRAWING IS A CONTROLLED DOCUMENT.		DWN J.SANDWELL 12NOV03	Tyco Electronics Corporation Stanmore, Middlesex, HA7 4RS	
DIMENSIONS: MM		CHK S.PARLOW 12NOV03		
TOLERANCES UNLESS OTHERWISE SPECIFIED:		APVD F.WHEELER-KING 12NOV03	NAME	
0 PLC ± - 1 PLC ± - 2 PLC ± - 3 PLC ± - 4 PLC ± - ANGLES ± -		PRODUCT SPEC 108-3462	MMCX STRAIGHT BULKHEAD JACK CRIMP RG178 50 OHMS	
MATERIAL SEE TABLE		FINISH SEE TABLE	APPLICATION SPEC 411-3278	RESTRICTED TO
		WEIGHT -	SIZE A3	CAGE CODE 00779
		CUSTOMER DRAWING	DRAWING NO C-1634006	REV B
		SCALE NTS	SHEET 1 OF 1	