

NOTES:

1. ELECTRICAL:

- A. IMPEDANCE: 50 Ω (NOMINAL)
- B. FREQUENCY RANGE: 0-6 GHz
- C. CONTACT RESISTANCE: CENTER: 20 mΩ MAX.: MEASURED AT 10mA MAX., 25 mΩ MAX AFTER CYCLING
OUTSIDE: 10 mΩ MAX.: MEASURED AT 10mA MAX., 15 mΩ MAX AFTER CYCLING
- D. INSULATION RESISTANCE: 500 MΩ MIN.: MEASURED AT 100V DC.
- E. WITHSTANDIN VOLTAGE: NO LINE OR INSULATION BREAKDOWN: 200V AC FOR 1 MIN.
- F. V.S.W.R. : 1.3 MAX. AT DC TO 3 GHz, 1.4 MAX. AT 3 TO 6 GHz
- G. TYPICAL INSERTION LOSS : 0.0022*L*√Frequency in GHz]+0.087*√Frequency in GHz]

2. PHYSICAL:

- A. FEMALE CONTACT HOLDING FORCE: 0.1 N MIN. : MEASURED WITH A Ø0.475 MM PIN GAUGE.
- B. DURABILITY: 30 CYCLES
- C. TEMPERATURE RANGE: -40°C TO +90°C.
- D. AMC CONNECTOR MATING FORCE: 20 N MAX.
- E. AMC CONNECTOR DEMATING FORCE: 10 N MIN.
- F. AMC INTERFACE IS FULLY COMPATIBLE WITH "U.FL" SERIES PRODUCT.

3. MATERIALS AND FINISHES(PLATING THICKNESS IN MICRO-INCHES):

- CONNECTOR BODY: PHOSPHOR BRONZE, AU 0.05 um MIN. PLATED OVER NI 1.0 um MIN.
- CONNECTOR CENTER CONTACT: PHOSPHOR BRONZE , AU 0.1 um MIN. PLATED OVER NI 1.0 um MIN.
- CONNECTOR INSULATOR: PBT, UL94V-0, WHITE
- CABLE JACKET: FEP
- CABLE DIELECTRIC: FEP
- CABLE CENTER CONDUCTOR: COPPER WIRE STRANDED, SILVER PLATED
- CABLE OUTER CONDUCTOR: COPPER WIRE BRAID, TIN PLATING

THIRD ANGLE PROJ.

REVISIONS

REV	DESCRIPTION	DATE	ECN	APPR
G	REDRAWN, GOLD PLATING WAS SILVER PLATING; OLD PN "A-IPAG" COMBINED TO "A-IPA-" ; NO "A-IPAG" FOR NEW PN	08-Jan-19	10390	JTS

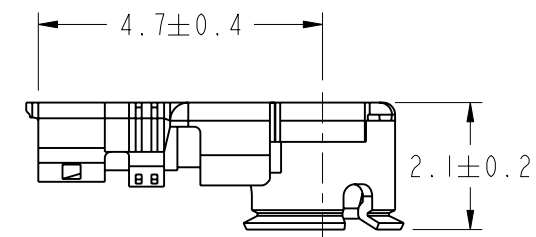
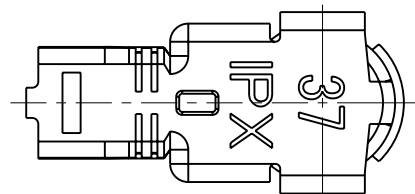
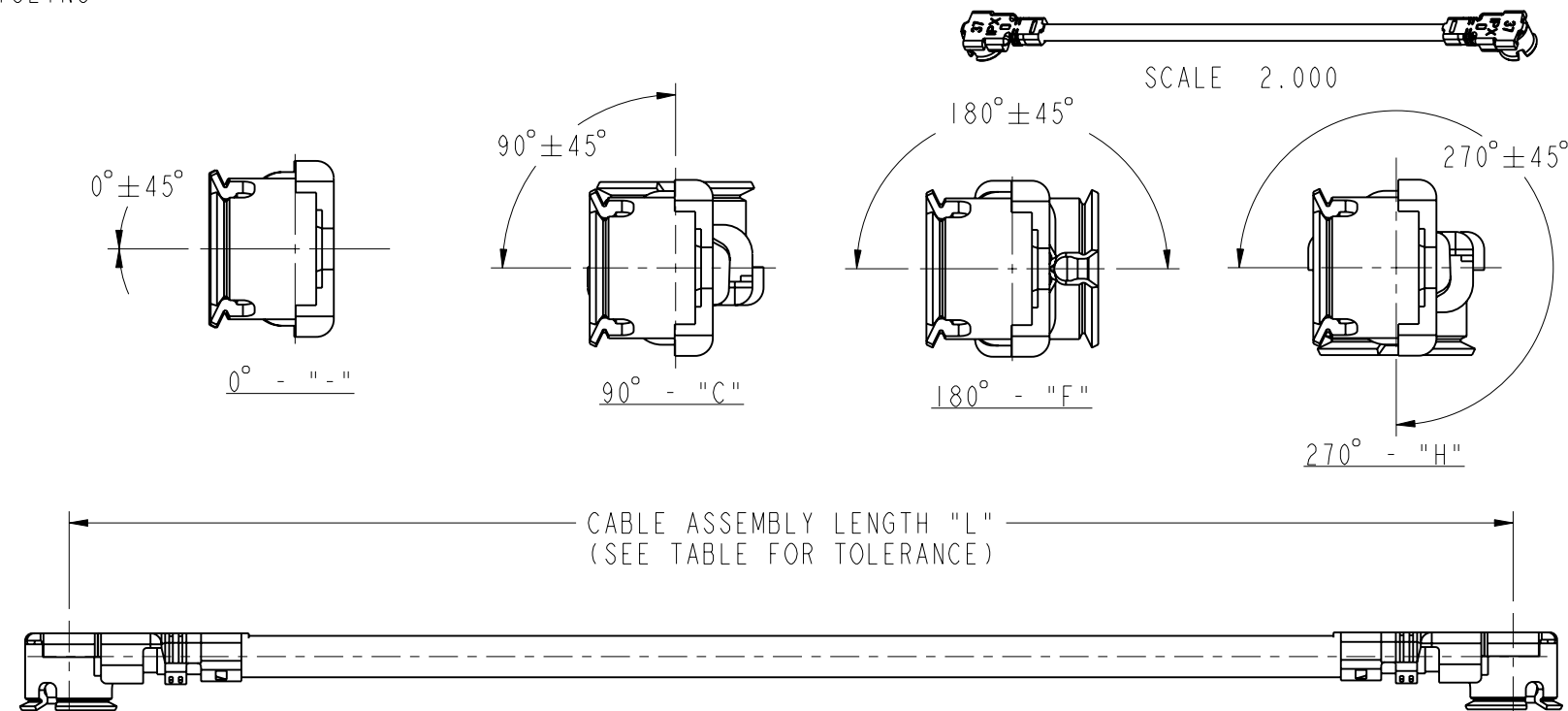

SCALE 8.000

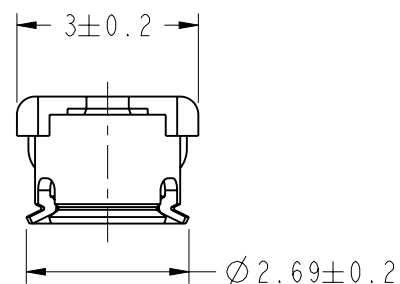

CABLE ASSEMBLY OVERALL LENGTH TOLERANCE	
OVERALL LENGTH L (mm)	STANDARD TOLERANCE (mm)
20 ≤ L < 35	± 2
35 ≤ L < 200	± 4
200 ≤ L < 500	± 8
500 ≤ L < 1000	± 12
1000 ≤ L	±1.5 %

A-IPAX137-XXXXYZ

- AMC RIGHT ANGLE PLUG
- CONNECTOR ORIENTATION:
 - = 0°
 - C = 90°
 - G = LEGACY, DO NOT USE FOR NEW DESIGNS
 - F=180°
 - H=270°
- CABLE TYPE: (137 = 1.37MM CABLE)
- CABLE LENGTH IN MM (L<1000MM):
 - EXAMPLE : 020 = 20MM
 - 150 = 150MM
 - CHANGE "-" TO "X" (L>=1000MM)
 - EXAMPLE : 1020 = 1020MM
- NUMBER OF TERMINATED ENDS (1 OR 2)
- CABLE COLOR:
 - A=ORANGE
 - B=BLACK
 - C=CURRY
 - E=GREEN
 - G=GRAY
 - N=BROWN
 - P=PURPLISH RED
 - R=RED
 - U=BLUE
 - W=WHITE
 - Y=YELLOW

CUSTOMER OUTLINE DRAWING

ALL OTHER SHEETS ARE FOR INTERNAL USE ONLY

UNLESS OTHERWISE SPECIFIED, DIMENSIONS ARE IN METRIC AND TOLERANCES ARE:
 <0.5mm ±0.05mm 0.5 - 6mm ±0.1mm 6 - 30mm ±0.2mm 30 - 120mm ±0.3mm ANGLES ±1°

NOTICE - These drawings, specifications, or other data (1) are, and remain the property of Amphenol corp. (2) must be returned upon request; and (3) are confidential and not to be disclosed to any person other than those to whom they are given by Amphenol Corp. the furnishing of these drawings, specifications, or other data by Amphenol Corp., or to any other person to anyone for any purpose is not to be regarded by implication or otherwise in any manner licensing, granting rights to permitting such holder or any other person to manufacture, use or sell any product, process or design, patented or otherwise, that may in any way be related to or disclosed by said drawings, specifications, or other data.

MATERIAL	DRAWN	DATE	TITLE
REFERENCE	JEKY	29-Jan-19	AMC PLUG TO AMC PLUG
EAR#	ENGINEER	DATE	JUMPER ASSEMBLY
REF:	FIGO	29-Jan-19	ON 1.37MM CABLE
CONFIGURATION LEVEL: In Work	APPROVED	DATE	SCALE: 3.0:1.0 SHEET 2 OF 2
FINISH	FIGO	12-Feb-19	DWG SIZE B
	CAD FILE		REV G

DRAWING NO. A-IPAX137-XXXXYZ
ITEM NO. A-IPAX137-XXXXYZ
PART NO. A-IPAX137-XXXXYZ

Amphenol RF	
www.amphenolrf.com	
DRAWING NO. A-IPAX137-XXXXYZ	
ITEM NO. A-IPAX137-XXXXYZ	
PART NO. A-IPAX137-XXXXYZ	

Amphenol RF	
www.amphenolrf.com	
DRAWING NO. A-IPAX137-XXXXYZ	
ITEM NO. A-IPAX137-XXXXYZ	
PART NO. A-IPAX137-XXXXYZ	