

## Evaluation Boards for Instrumentation Amplifiers: **AD620 to AD623, AD627, AD822x, LT1167, LT1168, LT6370, AD8236, AD8421, AD8428, and AD8429**

### FEATURES

3 generic, easy-to-use evaluation boards

Shipped with an assortment of Analog Devices in-amps

Solder in the in-amp to be tested

Test pins already populated

Decoupling capacitors already populated

**EVAL-INAMP-62RZ board**

Compatible with **LT1167, LT1168, LT6370, AD620, AD621, AD622, AD623, AD627, AD8223, and AD8225** in SOIC or PDIP

**EVAL-INAMP-82RZ board**

Compatible with **AD8221, AD8226, AD8227, AD8228, AD8229, AD8421, AD8428, and AD8429** in SOIC package

**EVAL-INAMP-82RMZ board**

Compatible with **AD8220, AD8221, AD8226, AD8227, AD8228, AD8236, and AD8421** in MSOP package

### GENERAL DESCRIPTION

This user guide describes three generic evaluation boards that can be used to evaluate many of Analog Devices, Inc., instrumentation amplifiers. For information on the performance of a specific instrumentation amplifier, see the data sheet for that instrumentation amplifier.

#### ***EVAL-INAMP-62RZ (SOIC or PDIP)***

The EVAL-INAMP-62RZ is designed for evaluation of instrumentation amplifiers in the legacy pinout. This board can be used to evaluate the **LT1167, LT1168, LT6370, AD620, AD621, AD622, AD623, AD627, AD8223, and AD8225** instrumentation amplifiers. In addition to the basic in-amp connection, circuit options enable the user to adjust the offset voltage, apply an output reference, or provide shield drivers with user-supplied components. The board is shipped with an assortment of instrumentation amplifier ICs in the legacy SOIC pinout. These include the **LT1167, LT1168, LT6370, AD620, AD621, AD622, AD623, AD8223, and AD8225**. The board also has an alternative footprint for a through-hole, 8-lead PDIP.

#### ***EVAL-INAMP-82RZ (SOIC)***

The EVAL-INAMP-82RZ is designed for evaluation of instrumentation amplifiers in the high performance pinout. This board can be used to evaluate the **AD8221, AD8226, AD8227, AD8228, AD8229, AD8421, AD8428, and AD8429**

### **EVAL-INAMP-62RZ, EVAL-INAMP-82RZ, AND EVAL-INAMP-82RMZ BOARD PHOTOGRAPH**

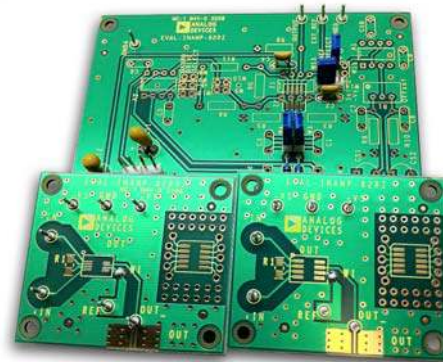

Figure 1.

in SOIC packages. The board is shipped with an assortment of instrumentation amplifier ICs in the high performance SOIC pinout. These include the **AD8221, AD8226, AD8421, AD8428, and AD8429**. The evaluation board is arranged so that users can easily solder on the gain resistor. The in-amp reference pin can connect to ground through a solder short or connect to the source of the user through the test pin. A small prototyping area allows interfacing to another part in an SOIC package.

Users can add their own SMA or SMB connector to interface the evaluation board with complementary tools, such as an analog-to-digital converter (ADC) evaluation board, available from Analog Devices.

#### ***EVAL-INAMP-82RMZ (MSOP)***

The EVAL-INAMP-82RMZ board is exactly the same as the EVAL-INAMP-82RZ board, except that it is designed for the MSOP pinout. This board can be used to evaluate the **AD8220, AD8221, AD8226, AD8227, AD8228, AD8236, and AD8421** in MSOP packages. The EVAL-INAMP-82RMZ board ships with an assortment of in-amp ICs in the high performance MSOP pinout, typically **AD8220, AD8221, AD8226, AD8228, and AD8421**.

**TABLE OF CONTENTS**

Features ..... 1  
 EVAL-INAMP-62RZ, EVAL-INAMP-82RZ, and EVAL-INAMP-82RMZ Board Photograph..... 1  
 General Description ..... 1  
 Revision History ..... 2  
 EVAL-INAMP-62RZ Details..... 3  
 Quick Start for the EVAL-INAMP-62RZ Board ..... 4  
     Circuit Options ..... 4  
     Load Resistor..... 4

CMRR Performance.....4  
 Guard Drivers .....5  
 Component Locations .....5  
 User Options .....6  
 Quick Start for the EVAL-INAMP-82RZ and EVAL-INAMP-82RMZ Boards.....7  
 Reference .....7  
 Output.....7

**REVISION HISTORY**

**10/2019—Rev. C to Rev. D**

Added LT1167, LT1168, and LT6370..... Throughout  
 Changed Document Subject from Evaluation Boards for the AD62x Series and the AD822x Series Instrumentation Amplifiers to Evaluation Boards for Instrumentation Amplifiers: AD620 to AD623, AD627, AD822x, LT1167, LT1168, LT6370, AD8236, AD8421, AD8428, and AD8429..... 1  
 Added EVAL-INAMP-62RZ, EVAL-INAMP-82RZ, and EVAL-INAMP-82RMZ Board Photograph Section ..... 1  
 Changes to Figure 2..... 3  
 Changes to Single-Supply Operation Section..... 4  
 Change to Figure 3 Caption ..... 5

**6/2012—Rev. B to Rev. C**

Changes to Features Section, EVAL-INAMP-62RZ (SOIC or PDIP) Section, EVAL-INAMP-82RZ (SOIC) Section, and EVAL-INAMP-82RMZ (MSOP) Section ..... 1  
 Changes to Quick Start for the EVAL-INAMP-82RZ and EVAL-INAMP-82RMZ Boards Section..... 7

**3/2011—Rev. A to Rev. B**

Changed Format to User Guide..... Throughout  
 Changes to Document Title ..... 1  
 Changes to Features Section..... 1  
 Deleted Applications Section ..... 1  
 Changes to General Description Section ..... 1  
 Added CMRR Performance Section ..... 4  
 Added Component Locations Section..... 5

**11/2008—Rev. 0 to Rev. A**

Combined AD623-EVALZ Data Sheet and AD623-EVAL Data Sheet..... Universal  
 Added AD8220/AD8221-EVALZ ..... Throughout  
 Changed AD623-EVALZ to AD620 Series-EVALZ..... Throughout  
 Changes to General Description .....1  
 Added EVAL-INAMP-62RZ Details Section.....3  
 Added Quick Start for the EVAL-INAMP-62RZ Boards Section.....4  
 Changes to Gain Adjustment Section.....4  
 Added Table 1 and Table 2; Renumbered Sequentially .....4  
 Changed Appendix Heading to User Options.....6  
 Added Quick Start for the EVAL-INAMP-82RZ Section and EVAL-INAMP-82RMZ Boards Section .....7  
 Changes to Ordering Guide .....8

**12/2007—Revision 0: AD623-EVALZ Initial Version**

**6/2003—Revision 0: AD623-EVAL Initial Version**

### EVAL-INAMP-62RZ DETAILS

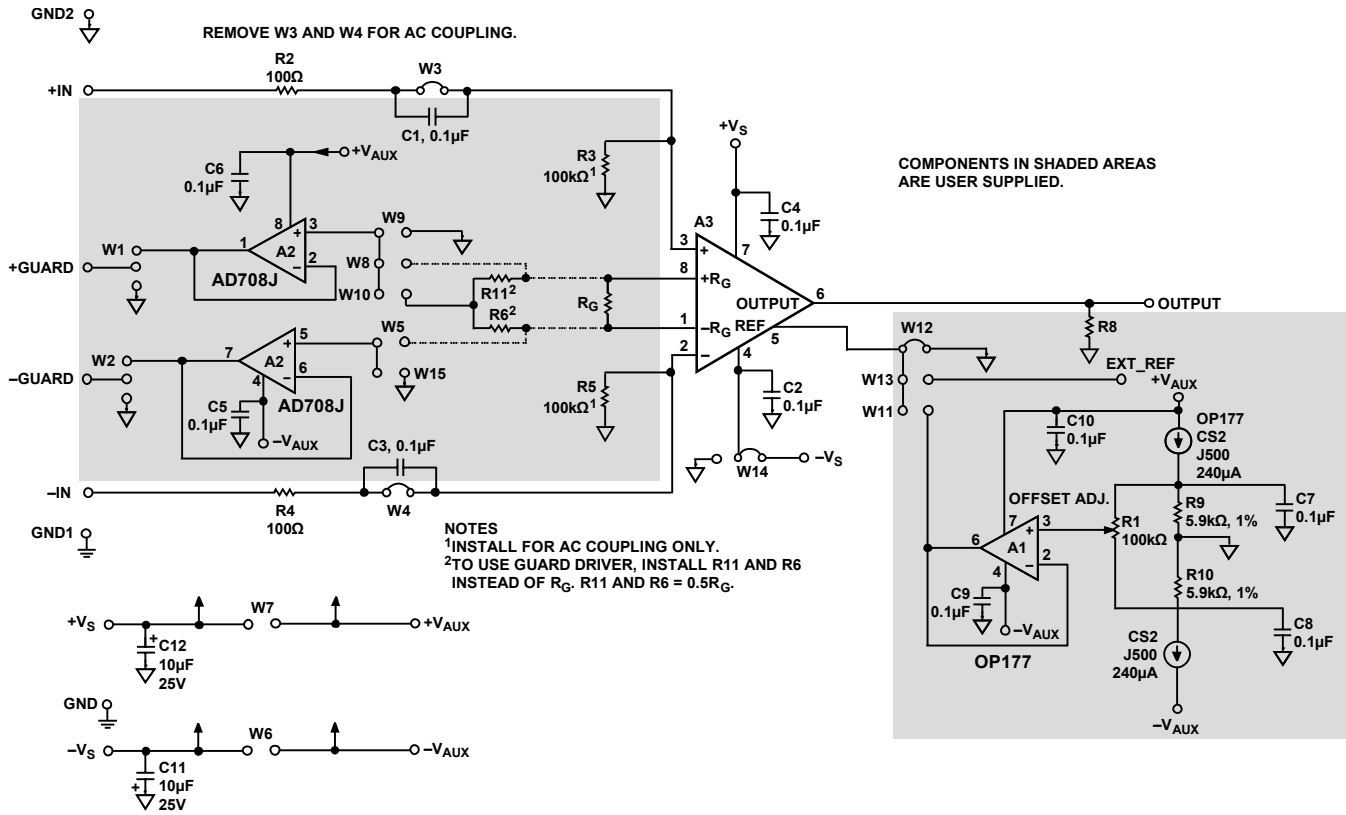

Figure 2. EVAL-INAMP-62RZ Schematic Diagram

09753-002

## QUICK START FOR THE EVAL-INAMP-62RZ BOARD

### CIRCUIT OPTIONS

#### Single-Supply Operation

A jumper is provided to select between single or dual power supplies. The evaluation board is shipped with W14 in the dual-supply position. To convert to single supply, place W14 in the position marked with a ground symbol.

The [LT6370](#) 8-lead plastic SOIC package exposed pad (V<sup>+</sup>) can be left floating when the device is used on the EVAL-INAMP-62RZ board.

#### Gain Adjustment

The gain of the [AD621](#) is pin selectable where  $G = 1$  (default) or  $G = 100$  (strap Pin 1 and Pin 8). In contrast, the gain of the [AD620](#), [AD622](#), and [AD623](#) devices is resistor dependent (the resistor is connected between the  $R_G$  pins). Without a resistor, the gain is unity. Table 1 to Table 3 provide calculated gains for each device. See the individual product data sheet for the gain equations.

**Table 1. AD620 Gain Resistor Values**

1% Standard Value of $R_G$ ( $\Omega$ )	Calculated Gain	0.1% Standard Value of $R_G$ ( $\Omega$ )	Calculated Gain
49.9 k	1.990	49.3 k	2.002
12.4 k	4.984	12.4 k	4.984
5.49 k	9.998	5.49 k	9.998
2.61 k	19.93	2.61 k	19.93
1.00 k	50.40	1.01 k	49.91
499	100.0	499	100.0
249	199.4	249	199.4
100	495.0	98.8	501.0
49.9	991.0	49.3	1003.0

**Table 2. AD622 Gain Resistor Values**

Desired Gain	1% Standard Value of $R_G$ ( $\Omega$ )	Calculated Gain
2	51.1 k	1.988
5	12.7 k	4.976
10	5.62 k	9.986
20	2.67 k	19.91
33	1.58 k	32.96
40	1.3 k	39.85
50	1.02 k	50.50
65	787	65.17
100	511	99.83
200	255	199.0
500	102	496.1
1000	51.1	989.3

**Table 3. AD623 Gain Resistor Values**

Desired Gain	1% Standard Value of $R_G$ ( $\Omega$ )	Calculated Gain
2	100 k	2
5	24.9 k	5.02
10	11 k	10.09
20	5.23 k	20.12
33	3.09 k	33.36
40	2.55 k	40.21
50	2.05 k	49.78
65	1.58 k	64.29
100	1.02 k	99.04
200	499	201.4
500	200	501
1000	100	1001

#### External Reference or Offset Adjustment

When shipped, the reference of the EVAL-INAMP-62RZ board is connected to ground. Certain single-supply applications (for example, an ADC connected to the output of the in-amp) require a symmetrical output voltage centered on a nonzero value. The reference can be equal to half the supply, or an application-specific voltage can be provided by an ADC. The user can install a jumper at W13 and connect an external reference to the EXT\_REF pin. To maintain proper operation of the in-amp, provide the reference by a voltage source.

Similarly, a provision is made for an offset adjustment of  $\pm 1.12$  V by installing the parts listed in Table 6. Although the A2 and A3 ICs can be used with a single or dual power supply connection, A1 requires a dual supply. To enable the offset feature, install a shunt in Position W11. To adjust the offset of the in-amp, ground both inputs and measure the output voltage. Adjust Potentiometer R1 for 0 V.

#### LOAD RESISTOR

Although not required for normal operation, a load resistor can be inserted at Position R8.

#### CMRR PERFORMANCE

The [AD621](#) CMRR performance degrades at gains of 100 when using this board due to the high performance of the [AD621](#).

**GUARD DRIVERS**

When interference from sources such as power lines must be reduced to levels below those provided by standard shielded cables, guard drivers may be effective. A guard equalizes the ac potential between the in-amp input and the cable shield of the line, effectively reducing the low frequency interference voltage.

A2 in Figure 3 is a dual op amp, AD708, driving the shield(s) of the input cable(s) from the gain resistor pins of the in-amp. The voltages at these pins are equal to the input voltages plus 0.6 V (see the device data sheet).

The EVAL-INAMP-62RZ provides single and differential guards. Differential guards drive the shields with essentially the same signals as the inputs, whereas the single guard can be used for dual conductor cables. In this mode, the +GUARD drives the shield at  $\frac{1}{2}(V_{IN\ DIFF}) + 0.6\ V$ .

To activate the guard drivers, +V<sub>AUX</sub> and -V<sub>AUX</sub> must be connected. For shielded cables at both inputs, install the W1, W2, W5, and W8 jumpers.

**Using a Single Guard**

When using the AD620, AD622, and AD623 for gains greater than 1, install Resistors R6 and R11 (which are each half the calculated resistance of R<sub>G</sub>) and Jumpers W1, W2, and W10. For a gain of 1, either Position R6 or Position R11 can be shorted to enable the guard driver input. Connect the shield to +GUARD. On the header pins that do not bear the ground symbol, insert a shunt across Position W1.

The guard drivers can be assembled using the components listed in Table 6.

**COMPONENT LOCATIONS**

Figure 3 shows the component layout and the location of connections for the EVAL-INAMP-62RZ board.

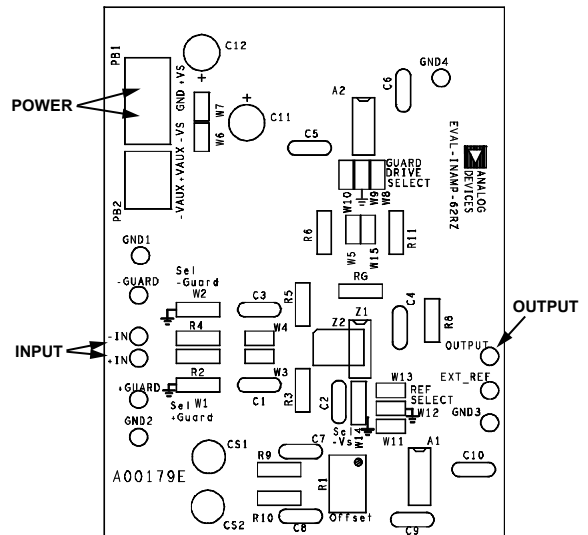

Figure 3. Component Location for the EVAL-INAMP-62RZ

## USER OPTIONS

Table 4. Jumpers

Jumper	Function	Description	Status
W1	+GUARD select	Allows the shield of the positive input cable to be connected to the guard driver or ground.	Not installed
W2	–GUARD select	Allows the shield of the negative input cable to be connected to the guard driver or ground.	Not installed
W3	+Input coupling	Installed; the positive input is dc-coupled.	Installed
W4	–Input coupling	Installed; the negative input is dc-coupled.	Installed
W5	Guard driver –IN	Connects the negative shield guard driver to Pin 1 of the in-amp.	Not installed
W6	–V <sub>S</sub> to –V <sub>AUX</sub>	Connects the negative supply voltage to the negative auxiliary voltage of the same value.	Not installed
W7	+V <sub>S</sub> to +V <sub>AUX</sub>	Connects the positive supply voltage to the positive auxiliary voltage of the same value.	Not installed
W8	Guard driver +IN	Connects the positive shield guard driver to Pin 8 of the in-amp.	Not installed
W9	Guard driver +IN	Connects the positive shield guard driver to ground.	Not installed
W10	Guard driver +IN	Selects the single-shield guard driver.	Not installed
W11	Reference input	Connects the reference of the in-amp to the offset-adjustable voltage reference.	Not installed
W12	Reference input	Connects the reference of the in-amp to ground.	Installed
W13	Reference input	Connects the reference of the in-amp to an external reference supply.	Not installed
W14	In-amp –V <sub>S</sub> source	Connects the in-amp –V <sub>S</sub> pin to GND or to –V <sub>S</sub> of the evaluation board.	Connected to –V <sub>S</sub>
W15	Guard driver –IN	Connects the negative shield guard driver to ground.	Not installed

Table 5. Input/Output

Input/Output	Function
+V <sub>S</sub> /–V <sub>S</sub>	Positive and negative rails of the in-amp.
GND	Ground for the board. GND1, GND2, GND3, and GND4 designate pins.
+IN/–IN	Positive and negative inputs of the in-amp.
+GUARD/–GUARD	Positive and negative terminals for use with a shielded cable.
EXT_REF	External reference input for the in-amp.
OUTPUT	Output of the in-amp.
+V <sub>AUX</sub> /–V <sub>AUX</sub>	Auxiliary power rails for guard drivers and offset reference circuitry.

Table 6. User-Supplied Parts for Guard and Offset Circuits

Reference Designation	Part
Guard Drivers	
C5, C6	0.1 μF, 25 V ceramic capacitor
A2	<a href="#">AD708JN</a> dual precision op amp
Offset Regulators	
C7 to C10	0.1 μF, 25 V ceramic capacitor
A1	<a href="#">OP177</a> precision op amp
CS1, CS2	J500 240 μA current source
R9, R10	5.9 kΩ, 1% metal film resistor

## QUICK START FOR THE EVAL-INAMP-82RZ AND EVAL-INAMP-82RMZ BOARDS

The quick start instructions in this section assume that the evaluation board is in default condition, as shown in Table 7. This section describes two separate evaluation boards, where the EVAL-INAMP-82RZ has an SOIC footprint and the EVAL-INAMP-82RMZ has an MSOP footprint.

**Table 7. Factory Setting**

Connection	Purpose
W1 is soldered.	REF is tied to ground.

Follow Step 1 through Step 3 to get started using these boards (see Figure 4).

1. Connect a  $\pm 2.3$  V to  $\pm 15$  V supply to  $+V_S$  and  $-V_S$ . (Consult the specific data sheet for power supply operating range.)
2. Drive the inputs with a signal.
3. Measure the output on a multimeter or oscilloscope. The output voltage is the voltage measured between  $V_{OUT}$  (OUT) and  $V_{REF}$  (REF). The output can drive another device, such as an ADC.

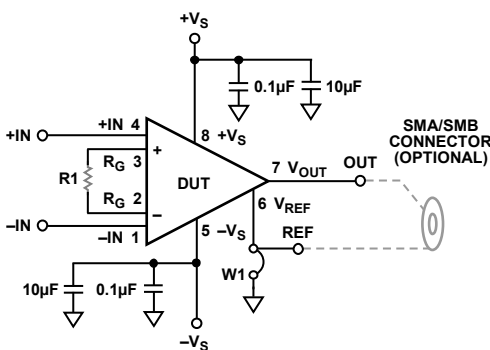

Figure 4. EVAL-INAMP-82RZ Schematic

### REFERENCE

The reference level of the instrumentation amplifier can be set by driving the REF pin with a precision voltage reference or by using the solder jumper, W1. By default, W1 is soldered, shunting REF to ground. If a reference voltage other than ground is used, the solder must be removed from W1 before driving REF with the reference voltage, as shown in Figure 5.

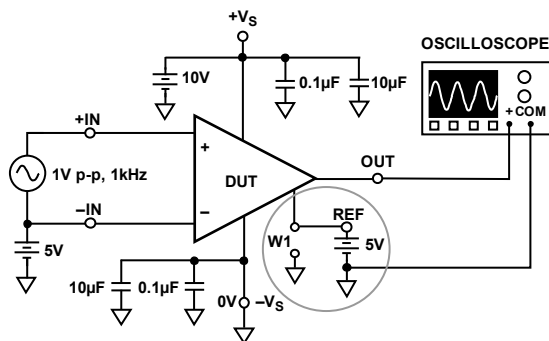

Figure 5. Using an External Voltage Source to Set the Reference Level (Circled) Input

Do not leave the in-amp inputs floating, that is, without a dc return path. This often occurs when the inputs are connected to a transformer, a thermocouple, or a pair of series capacitors. The inputs should have a dc path to ground, as shown in Figure 5 and Figure 6.

The circuit shown in Figure 6 has series capacitors, C1 and C2, between the signal generator and the input. The series capacitors prevent a dc current from flowing into the input transistors of the instrumentation amplifier. Two matched 10 k $\Omega$  resistors are used between the instrumentation amplifier inputs and ground to provide the necessary current path. Closely match these resistors to reduce offset and CMRR errors.

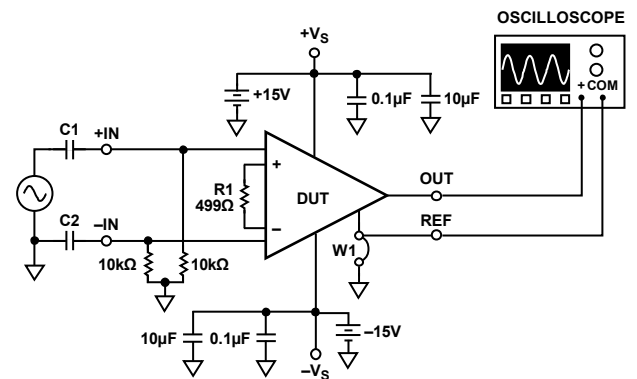

Figure 6. AC Input Coupling Using a Resistive DC Return Path

### OUTPUT

Make output measurements by monitoring the voltage between the OUT and REF tie points of the board, as shown in Figure 7. If an external voltage reference is used, the output can be measured, referred to ground, as shown in Figure 5. The evaluation board offers an SMA/SMB outline. By default, the output voltage measured using an SMA/SMB connector is with respect to ground.

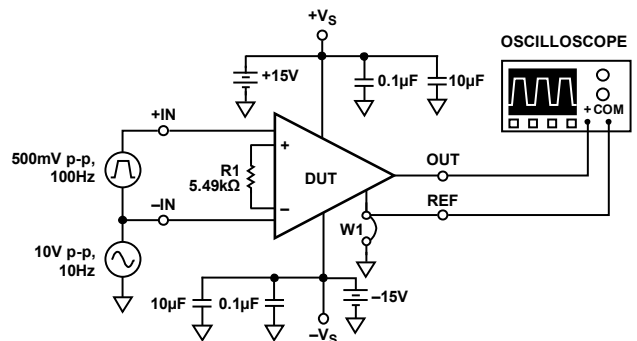

Figure 7. Correct Output Connection Using the REF Pin

## NOTES

**ESD Caution**

**ESD (electrostatic discharge) sensitive device.** Charged devices and circuit boards can discharge without detection. Although this product features patented or proprietary protection circuitry, damage may occur on devices subjected to high energy ESD. Therefore, proper ESD precautions should be taken to avoid performance degradation or loss of functionality.

**Legal Terms and Conditions**

By using the evaluation board discussed herein (together with any tools, components documentation or support materials, the "Evaluation Board"), you are agreeing to be bound by the terms and conditions set forth below ("Agreement") unless you have purchased the Evaluation Board, in which case the Analog Devices Standard Terms and Conditions of Sale shall govern. Do not use the Evaluation Board until you have read and agreed to the Agreement. Your use of the Evaluation Board shall signify your acceptance of the Agreement. This Agreement is made by and between you ("Customer") and Analog Devices, Inc. ("ADI"), with its principal place of business at One Technology Way, Norwood, MA 02062, USA. Subject to the terms and conditions of the Agreement, ADI hereby grants to Customer a free, limited, personal, temporary, non-exclusive, non-sublicensable, non-transferable license to use the Evaluation Board FOR EVALUATION PURPOSES ONLY. Customer understands and agrees that the Evaluation Board is provided for the sole and exclusive purpose referenced above, and agrees not to use the Evaluation Board for any other purpose. Furthermore, the license granted is expressly made subject to the following additional limitations: Customer shall not (i) rent, lease, display, sell, transfer, assign, sublicense, or distribute the Evaluation Board; and (ii) permit any Third Party to access the Evaluation Board. As used herein, the term "Third Party" includes any entity other than ADI, Customer, their employees, affiliates and in-house consultants. The Evaluation Board is NOT sold to Customer; all rights not expressly granted herein, including ownership of the Evaluation Board, are reserved by ADI. CONFIDENTIALITY. This Agreement and the Evaluation Board shall all be considered the confidential and proprietary information of ADI. Customer may not disclose or transfer any portion of the Evaluation Board to any other party for any reason. Upon discontinuation of use of the Evaluation Board or termination of this Agreement, Customer agrees to promptly return the Evaluation Board to ADI. ADDITIONAL RESTRICTIONS. Customer may not disassemble, decompile or reverse engineer chips on the Evaluation Board. Customer shall inform ADI of any occurred damages or any modifications or alterations it makes to the Evaluation Board, including but not limited to soldering or any other activity that affects the material content of the Evaluation Board. Modifications to the Evaluation Board must comply with applicable law, including but not limited to the RoHS Directive. TERMINATION. ADI may terminate this Agreement at any time upon giving written notice to Customer. Customer agrees to return to ADI the Evaluation Board at that time. LIMITATION OF LIABILITY. THE EVALUATION BOARD PROVIDED HEREUNDER IS PROVIDED "AS IS" AND ADI MAKES NO WARRANTIES OR REPRESENTATIONS OF ANY KIND WITH RESPECT TO IT. ADI SPECIFICALLY DISCLAIMS ANY REPRESENTATIONS, ENDORSEMENTS, GUARANTEES, OR WARRANTIES, EXPRESS OR IMPLIED, RELATED TO THE EVALUATION BOARD INCLUDING, BUT NOT LIMITED TO, THE IMPLIED WARRANTY OF MERCHANTABILITY, TITLE, FITNESS FOR A PARTICULAR PURPOSE OR NON-INFRINGEMENT OF INTELLECTUAL PROPERTY RIGHTS. IN NO EVENT WILL ADI AND ITS LICENSORS BE LIABLE FOR ANY INCIDENTAL, SPECIAL, INDIRECT, OR CONSEQUENTIAL DAMAGES RESULTING FROM CUSTOMER'S POSSESSION OR USE OF THE EVALUATION BOARD, INCLUDING BUT NOT LIMITED TO LOST PROFITS, DELAY COSTS, LABOR COSTS OR LOSS OF GOODWILL. ADI'S TOTAL LIABILITY FROM ANY AND ALL CAUSES SHALL BE LIMITED TO THE AMOUNT OF ONE HUNDRED US DOLLARS (\$100.00). EXPORT. Customer agrees that it will not directly or indirectly export the Evaluation Board to another country, and that it will comply with all applicable United States federal laws and regulations relating to exports. GOVERNING LAW. This Agreement shall be governed by and construed in accordance with the substantive laws of the Commonwealth of Massachusetts (excluding conflict of law rules). Any legal action regarding this Agreement will be heard in the state or federal courts having jurisdiction in Suffolk County, Massachusetts, and Customer hereby submits to the personal jurisdiction and venue of such courts. The United Nations Convention on Contracts for the International Sale of Goods shall not apply to this Agreement and is expressly disclaimed.

©2003–2019 Analog Devices, Inc. All rights reserved. Trademarks and registered trademarks are the property of their respective owners.  
UG09753-0-10/19(D)



www.analog.com