



HARWIN

Component Specification

C00611

Sub-Miniature Sockets
November 2022

SECTION	TITLE	PAGE
1	Description of Connector and Intended Application	2
2	Ratings	2
Appendix 1	Gauges	3

1. DESCRIPTION OF CONNECTOR AND INTENDED APPLICATION

The sub-miniature sockets are designed to allow I.C. devices to be mounted onto printed circuit boards, giving virtually zero above-board profile. The added advantage is of allowing tracks to be taken between the sockets, spaced on 2.54mm pitch centres. The socket is a clearance fit into a Ø1mm hole, and has a closed body design to eliminate solder wicking.

The socket consists of an outer brass shell, with tapered entry for I.C. leads, and an inner spring contact. This contact is manufactured from beryllium copper with four contact fingers. Both shell and spring contact have a choice of gold or tin finish with nickel undercoat.

This high reliability socket is designed to meet severe environmental conditions of shock, vibration, bump, etc. It is intended for applications where space is limited.

2. RATINGS

2.1. Electrical Characteristics

Current Rating (in isolation):

25°C ambient	2.0A max
85°C ambient	1.75A max

Contact Resistance (maximum):

Initial	15mΩ
After conditioning	25mΩ

2.2. Environmental Characteristics

Environmental classification	55/125/56 at 95% RH
Operating Temperature Range	-55°C to +125°C
Low Air Pressure Severity	300 mbar
Vibration Severity	10Hz to 2,000Hz at 0.75mm, 98m/s ² (10G), duration 6 hours
Bump Severity	390m/s ² (40G), 4000 bumps
Shock Severity	981m/s ² (100G) for 6ms

2.3. Mechanical Characteristics

Durability:

Gold on contact area	500 mating operations
Tin on contact area	50 mating operations

Clip retention in body

10N min
*Minimum retention force may be 10N from a sample of 10 sockets,
providing the average of the samples is 22N.*

Insertion Force:

Initial	6.0N max
After Conditioning	2.0N min

Withdrawal Force:

Initial	1.5N max
After Conditioning	0.5N min

APPENDICES NOTES:

1. Third angle projection is used where projected views are shown.
2. All dimensions are in millimetres.
3. For explanation of dimensions, etc. see BS8888.
4. Unless otherwise stated, all dimensions are maxima.

APPENDIX 1 – GAUGES**NOTES:**

1. Material = Steel to BS1407 or equivalent.
2. Gauging surfaces to be hardened/ground, 650 HV5 min.
3. These gauges to be used for testing fully assembled components only.
4. Ultimate wear limit 0.005mm is allowable on gauging dimensions.

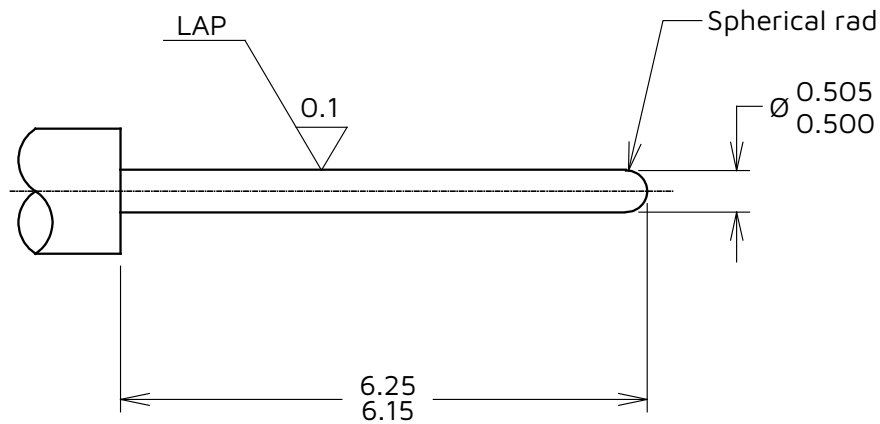
A1.1. Insertion and Withdrawal Gauge**A1.2. Holding Gauge (After conditioning)**

Mass = 50 ± 1 gm

