

**LOW -VOLTAGE ADJUSTABLE
PRECISION SHUNT REGULATOR**
PRELIMINARY DATASHEET

FEATURES

- SOT23-5 package
- 0.5% Voltage Reference Initial Accuracy (IRU431AL)
- Low Operational Cathode Current (80µA max)
- Unconditionally Stable with only 1µF
- Adjustable Output from 1.24V to 15V
- 0.25Ω Typical Output Impedance
- Pin to Pin Compatible with TLV431

APPLICATIONS

- Precision Voltage Reference
- Linear Regulator Controller
- Secondary Side Controller for the Low Voltage Power Supply Applications

DESCRIPTION

The IRU431L is a three-terminal adjustable shunt regulator that can also be used as a precision voltage reference. Its output voltage may be set to any value between Vref(1.24V) and 6V with two external resistors as shown in the typical application circuit. Other applications of this device include the use as a merged amplifier and reference in applications such as a linear regulator or as the secondary side controller in low voltage power supply applications. The IRU431L only requires 80µA maximum quiescent current before regulating, making it ideal as a voltage reference for battery type applications.

TYPICAL APPLICATION

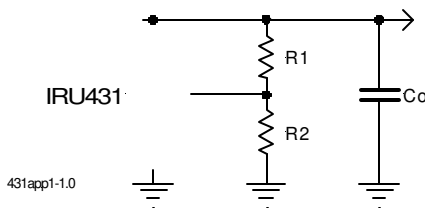

$$V_o = V_{ref} \times \left(1 + \frac{R_1}{R_2} \right)$$

Typical application of the IRU431L as a shunt regulator / voltage reference

PACKAGE ORDER INFORMATION

Ta (°C)	5-LEAD SOT23-5	PKG MARK	3-LEAD SOT-23	PKG MARK	8-PIN PLASTIC SOIC
0 TO 70	IRU431LCL5	431L	IRU431LCL3	431L	IRU431LCS
0 TO 70	IRU431ALCL5	431A	IRU431ALCL3	431A	IRU431ALCS

IRU431L/IRU431AL

ABSOLUTE MAXIMUM RATINGS

Input Voltage (V_{in})	15V
Continuous Cathode Current Range	-15mA to +15mA
Reference Current Range	-0.05mA to 1mA
Storage Temperature Range	-65°C TO 150°C
Operating Junction Temperature Range	0°C TO 150°C

PACKAGE INFORMATION

5-PIN SOT-23 (L)	3-PIN SOT-23 (L3)	8-PIN PLASTIC SOIC (S)

ELECTRICAL SPECIFICATIONS

Unless otherwise specified, these specifications apply over $T_a=0$ to 70 °C, $C_o=1\mu F$. Typical values refer to $T_a=25$ °C. Low duty cycle pulse testing is used which keeps junction and case temperatures equal to the ambient temperature.

PARAMETER	SYM	TEST CONDITION	MIN	TYP	MAX	UNITS
Reference Voltage IRU431L	Vref	$I_k=10mA$, $V_{KA}=V_{ref}$, $T_a=25^\circ C$	1.228	1.240	1.252	V
Reference Voltage IRU431AL	Vref	$I_k=10mA$, $V_{KA}=V_{ref}$, $T_a=25^\circ C$	1.234	1.240	1.246	V
Vref deviation over full temperature range	Vref(dev)	$V_{KA}=V_{ref}$, $I_k=10mA$ Note 1		6	12	mV
Ratio of Vref change to cathode voltage change	dVref/dV _{KA}	$I_k=10mA$, dV _{KA} =Vref to 6 V		-1	-3	mV/V
Reference pin current		$I_k=10mA$, R1=10kΩ, R2=open		0.15	1	μA
Iref deviation over full temperature range	Iref(dev)	$I_k=10mA$, R1=10kΩ, R2=open Note 1		0.05	0.3	μA
Minimum cathode current	$I_k(min)$	$V_{KA}=V_{ref}$		55	80	μA
Off state cathode current	I_{off}	$V_{KA}=6V$, $V_{ref}=0V$ $V_{KA}=10V$, $V_{ref}=0V$ $V_{KA}=15V$, $V_{ref}=0V$		0.3 2.8 4	0.75 5 10	μA
Dynamic impedance	Zka0	$V_{KA}=V_{ref}$, $f<1$ kHz, $I_k=0.1$ to 15 mA, Note 2		0.25	0.4	Ω

Note 1: The deviation parameters, Vref(dev) and Iref(dev) are defined as the differences between the maximum and the minimum values obtained over the rated temperature range. The average full range temperature coefficient of the reference input voltage is defined as:

$$|\alpha V_{ref}| = \frac{\left(\frac{V_{ref}(dev)}{V_{ref}(25^\circ C)} \right) \times 10^6}{\Delta T_A}$$

Where:

$|\alpha V_{ref}|$ unit is ppm/°C

ΔT_A is the rated operating free air temperature of the device.

αV_{ref} can be positive or negative depending on whether minimum Vref or maximum Vref, respectively occurs at the lower temperature.

Note 2:

The dynamic impedance when $V_{KA} = V_{ref}$ is defined as :

$$|Z_{ka0}| = \frac{\Delta V_{KA}}{\Delta I_k}$$

When the device is operating with two external resistors (see Figure 2), the total dynamic impedance of the circuit is given by:

$$|Z_{ka}| = \frac{\Delta V}{\Delta I} = |Z_{ka0}| \times \left(1 + \frac{R1}{R2} \right)$$

PIN DESCRIPTIONS

SOT-23 5-PIN PIN#	SOT-23 3-PIN PIN#	8-PIN SOIC PIN#	PIN SYMBOL	Pin Description
4	1	8	Ref	A resistor divider from this pin to the cathode pin and ground sets the output voltage.
3	2	1	Cathode	The output of the shunt regulator. A minimum of 1 μ F capacitor must be connected from this pin to Anode pin to insure unconditional stability.
5	3	3,6	Anode	Ground pin. This pin must be connected to the lowest potential in the system and all other pins must be at higher potential with respect to this pin.
1,2	NA	2,4,5,7	NC	These pins are not connected internally.

BLOCK DIAGRAM

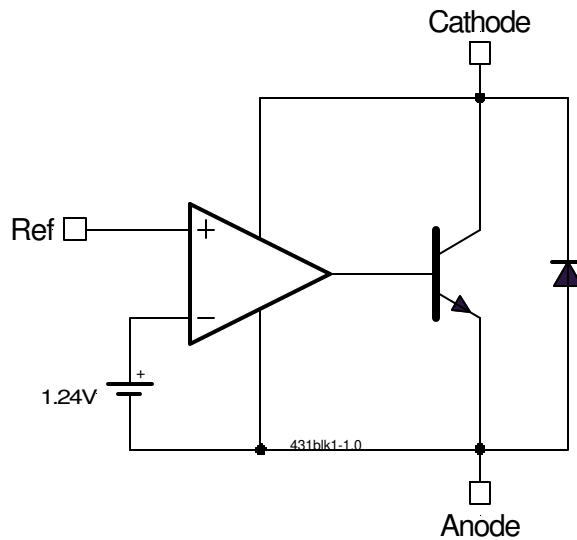

Figure 1 - Simplified block diagram of the IRU431L

IRU431L/IRU431AL

APPLICATION INFORMATION

Output Voltage Setting

The IRU431L can be programmed to any voltages in the range of 1.24 to 6V with the addition of R1 and R2 external resistors according to the following formula:

$$V_O = V_{KA} = V_{ref} \times \left(1 + \frac{R_1}{R_2}\right) + I_{ref} \times R_1$$

The IRU431L keeps a constant voltage of 1.240V between the Ref pin and ground pin. By placing a resistor R2 across these two pins a constant current flows through R2, adding to the Iref current and into the R1 resistor producing a voltage equal to the $(1.240/R_2) \times R_1 + I_{ref} \times R_1$ which will be added to the 1.240V to set the output voltage as shown in the above equation. Since the input bias current of the Ref pin is 0.5µA max, it adds a very small error to the output voltage and for most applications can be ignored. For example, in a typical 5V to 3.3V application where $R_2=1.21k\Omega$ and $R_1=2k\Omega$ the error due to the load is only 1mV which is about 0.03% of the nominal set point.

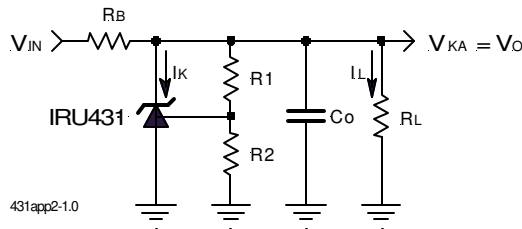

Figure 2 - Typical application of the IRU431L for programming the output voltage

Biasing Resistor (RB) Selection

The biasing resistor R_B is selected such that it does not limit the input current under the minimum input supply and maximum load and biasing current. An example is given below on how to properly select the biasing resistor.

Assuming:
 $V_{MIN} = 4.5\text{ V}$
 $V_{MAX} = 6\text{ V}$
 $V_{KA} = 3.3\text{ V}$
 $I_L = 10\text{ mA}$

The maximum value for the biasing resistor is calculated using the following equations:

$$R_{B_{MAX}} = \frac{V_{MIN} - V_{KA}}{I_{B_{MAX}} + I_{L_{MAX}}}$$

$$I_{B_{MAX}} = I_{K_{MIN}} + I_R$$

Where :

V_{MIN} = Minimum supply voltage

$I_{L_{MAX}}$ = Maximum load current

$I_{B_{MAX}}$ = Maximum bias current

$I_{K_{MIN}}$ = Maximum value for the minimum cathode current spec

I_R = Current through R1

Assuming $R_1=2k\Omega$ as before,

$$I_R = \frac{3.3 - 1.24}{2} = 1.03\text{ mA}$$

$$I_{B_{MAX}} = 0.08 + 1.03 = 1.11\text{ mA}$$

$$R_{B_{MAX}} = \frac{4.5 - 3.3}{1.11 + 10} = 108\ \Omega$$

Selecting $R_B = 100\ \Omega$

The maximum power dissipation of the resistor is calculated under the maximum supply voltage as follows:

$$P_{R_B(MAX)} = \frac{(V_{MAX} - V_{KA})^2}{R_B}$$

Where :

V_{MAX} = Maximum supply voltage

$P_{R_B(MAX)}$ = Maximum R_B power dissipation

$$P_{R_B(MAX)} = \frac{(6 - 3.3)^2}{100} = 73\text{ mW}$$

Thermal Design

The IRU431L is offered in the plastic 8-pin SOIC or the surface mount SOT23-5 (L) packages. The 8-pin SOIC package has the maximum power dissipation capability of 775mW at $T_a=25^\circ\text{C}$ with the derating factor of -6.2mW / $^\circ\text{C}$. The SOT23-5 package has the maximum power dissipation capability of 150mW at $T_a=25^\circ\text{C}$ with the derating factor of -1.2mW / $^\circ\text{C}$.

Table below summarizes the maximum power dissipation capability of each package versus ambient temperature.

Pkg	Ambient Temperature (T_a) $^\circ\text{C}$				
	25	40	50	60	70
8-Pin SOIC	775mW	682mW	620mW	558mW	496mW
SOT23-5	150mW	132mW	120mW	108mW	96mW

In our previous example, the maximum power dissipation of the device is calculated under no load and maximum input supply condition.

The maximum power is calculated using the following equation:

$$P_{MAX} = V_{KA} \times \left(\frac{V_{MAX} - V_{KA}}{R_B} \right)$$

Where :

P_{MAX} = Maximum power dissipation of the 431L

For our example :

$$P_{MAX} = 3.3 \times \left(\frac{6 - 3.3}{100} \right) = 89 \text{ mW}$$

As shown in the power dissipation table, both packages can handle this power dissipation.

Stability

The IRU431L has many different regions of stability domain as a function of the cathode current which are typical characteristics of the three-terminal shunt regulators. However, in general the device will be unconditionally stable for any cathode current if the capacitor, $C_o = 1\mu\text{F}$ or bigger is connected from cathode to anode pins. If the cathode current is always kept higher than 3mA under minimum line and maximum load conditions, the C_o can be cut to $0.01\mu\text{F}$ and the system will be stable.

IRU431L/IRU431AL

TYPICAL APPLICATION

I740 Application

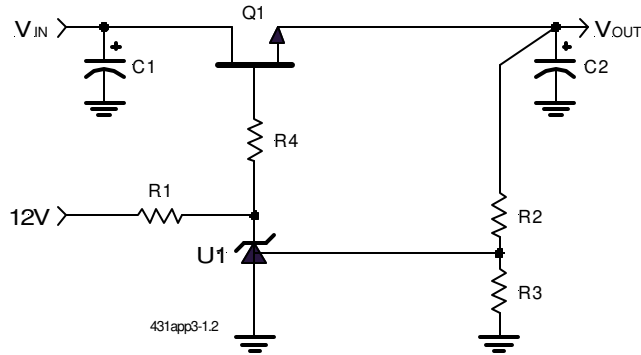

Figure 3- Low cost 3.3V to 2.7V output for Intel I740 application.

Ref Desig	Description	Qty	Part #	Manuf
U1	Shunt Regulator	1	IRU431L	IR
C1,2	Capacitor	2	Elect,220 μ F,6.3V,ECAOJFQ221	Panasonic
R1	Resistor	1	6.2k Ω , 5%, SMT	
R2	Resistor	1	118 Ω , 1%, SMT	
R3,R4	Resistor	2	100 Ω , 1% SMT	
HS1	Heat Sink		Use minimum of 1" square copper pad area for load current <4A	