

FEMALE-FEMALE ADAPTER

R222.705.000

Series : SMP

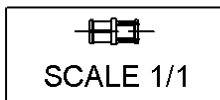
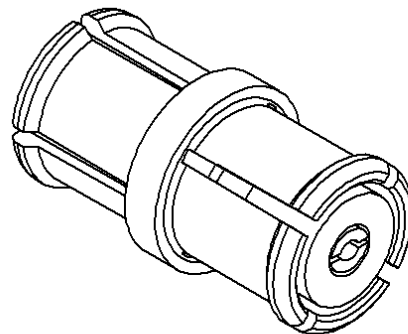
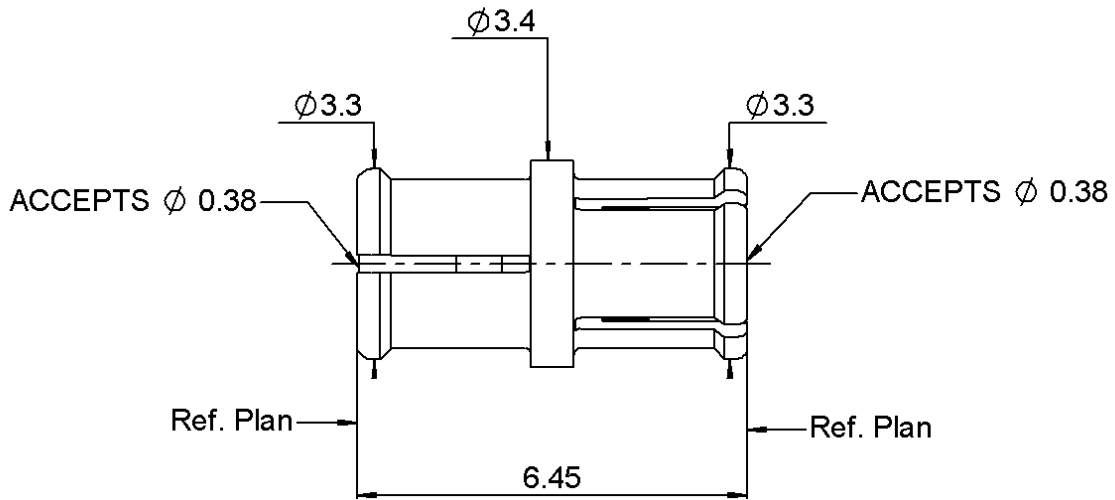

All dimensions are in mm.



COMPONENTS	MATERIALS	PLATINGS (µm)
BODY	BERYLLIUM COPPER	GOLD 1.3 OVER NICKEL 2
CENTER CONTACT	BERYLLIUM COPPER	GOLD 1.27 OVER NICKEL 1.27
OUTER CONTACT	-	-
INSULATOR	PTFE	-
GASKET	-	-
OTHERS PARTS	-	-
-	-	-
-	-	-

Issue : 0529 B

In the effort to improve our products, we reserve the right to make changes judged to be necessary.



FEMALE-FEMALE ADAPTER

R222.705.000

Series : SMP

PACKAGING

SPECIFICATION

Standard	Unit	Other
100	'W' option	Contact us

ELECTRICAL CHARACTERISTICS

ENVIRONMENTAL

Impedance	50	Ω
Frequency	0-40	GHz
VSWR	1.5 + 0,0000	x F(GHz) Maxi
Insertion loss	0.12	\sqrt{F} (GHz) dB Maxi
RF leakage	- (NA)	- F(GHz)) dB Maxi
Voltage rating	335	Veff Maxi
Dielectric withstanding voltage	500	Veff mini
Insulation resistance	5000	M Ω mini

Operating temperature	-65/+165	$^{\circ}$ C
Hermetic seal	NA	Atm.cm3/s
Panel leakage	NA	

OTHERS CHARACTERISTICS

Assembly instruction

Others :
Compliant wih MIL-STD-348

MECHANICAL CHARACTERISTICS

Center contact retention		
Axial force – Mating end	6.7	N mini
Axial force – Opposite end	6.7	N mini
Torque	NA	N.cm mini
Recommended torque		
Mating	NA	N.cm
Panel nut	NA	N.cm
Mating life	100	Cycles mini
Weight	0,1690	g

Issue : 0529 B

In the effort to improve our products, we reserve the right to make changes judged to be necessary.



FEMALE-FEMALE ADAPTER**R222.705.000**

Series : SMP

**ADDITIONAL INFORMATIONS
MOUNTING AND REPLACEMENT INSTRUCTIONS**

1 - INFORMATIONS

Mechanical durability: 100 cycles -> full detent connector .
 : 500 cycles -> limited detent connector .
 : 1000 cycles-> smooth bore connector .

Axial misalignement = 0/+0.25 mm.

Radial misalignement = ±0.25mm.

Force to:	engage	-	disengage	-	connector
Full det:	66.75 N maxi	-	22.25 N mini	-	FULL DETENT
Limited:	44.5 N maxi	-	8.9 N mini	-	LIMITED DET.
Smooth b:	8.9 N maxi	-	2.225 N mini	-	SMOOTH BORE

2 - MOUNTING AND REPLACEMENT

Adaptor must be mounted or removed with tooling R282.918.100.

2-1 - Push in F direction to open the tool .

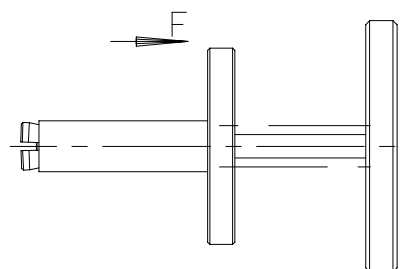

2-2 - Place the adaptor into the tool ,
 until it bottoms against .

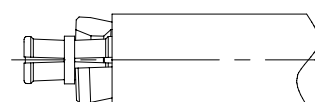

2-3 - Push on the adaptor , and release
 the smallest tool diameter.
 (the force to fixe the adaptor is
 applied by a spring) .

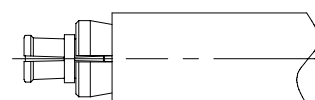

2-4 - Push on the biggest tool diameter to place the adaptor .
 - To remove the adaptor , pull off on the biggest tool diameter .

Issue : 0529 B

In the effort to improve our products, we reserve the right to make changes judged to be necessary.

