

DESCRIPTION: MALE - 0.370 RIGHT ANGLE / MACHINED - ECONOMY

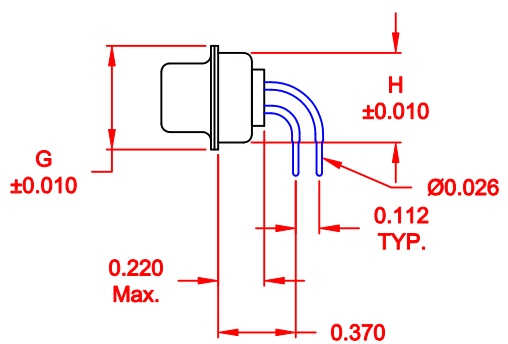
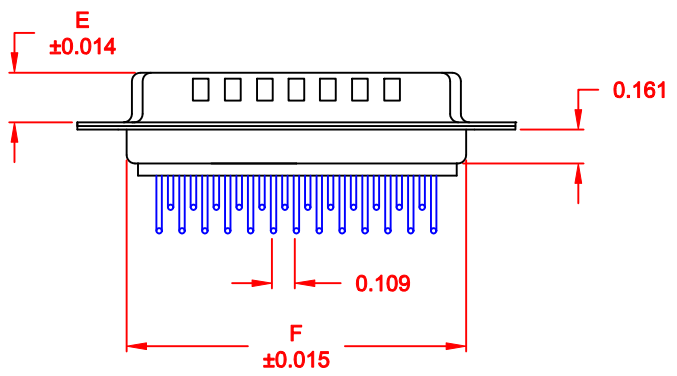
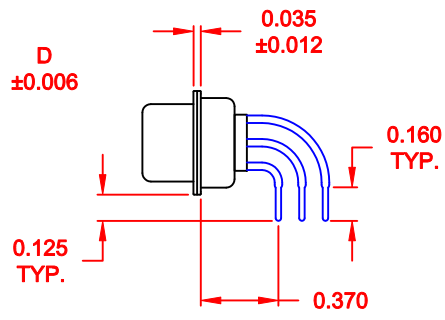
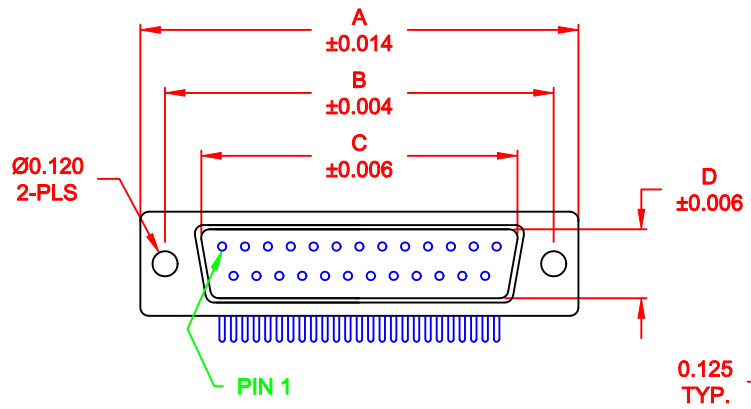

No. OF PINS	DIMENSIONS							
	A	B	C	D	E	F	G	H
9	1.213	0.984	0.666	0.329	0.236	0.756	0.496	0.427
	30.80	24.99	16.92	8.36	5.99	19.20	12.60	10.85
15	1.541	1.312	0.994	0.329	0.236	1.091	0.496	0.427
	39.15	33.32	25.25	8.36	5.99	27.70	12.60	10.85
25	2.087	1.852	1.534	0.329	0.236	1.618	0.496	0.427
	53.00	47.04	38.96	8.36	5.99	41.10	12.60	10.85
37	2.728	2.500	2.182	0.329	0.236	2.256	0.496	0.427
	69.30	63.50	55.42	8.36	5.99	57.30	12.60	10.85
50	2.638	2.406	2.079	0.436	0.240	2.169	0.602	0.527
	67.00	61.11	52.80	11.07	6.10	55.10	15.30	13.39

174-EYY-111RYY1

- SERIES _____
- POSITIONS _____
- E09 _____
- E15 _____
- E25 _____
- E37 _____
- E50 _____
- GENDER _____
- 1 = MALE
- TERMINATION _____
- 1 = PC MOUNTING
- SHELL PLATING _____
- 1 = YELLOW CHROMATE (NON-ROHS)
- HARDWARE OPTIONS _____
- 00 = NO HARDWARE
- 14 = SHORT BRACKET WITH 4-40 SCREW LOCK
- 24 = SHORT BRACKET WITH 4-40 SCREW
- PLATING OPTIONS _____
- 1 = GOLD FLASH
- 2 = 30MICRO-INCH GOLD

MATERIAL:

SHELL: STEEL, YELLOW CHROMATE
 INSULATOR: UL 94V-O RATED, WHITE PA6T
 PROCESS TEMP.: 260° PROCESS TEMPERATURE
 CONTACT: BRASS

ELECTRICAL:

CURRENT RATING: 5 AMPS
 CONTACT RESISTANCE: 15 mOhms Max.
 INSULATION RESISTANCE: 1,000 MOhms min.
 VOLTAGE: 500VAC FOR 1 MINUTE
 TEMPERATURE: -50° C TO 100° C

DO NOT SCALE FROM DRAWING

	THESE DRAWINGS AND SPECIFICATIONS ARE THE PROPERTY OF NorComp AND SHALL NOT BE REPRODUCED, COPIED OR USED AS THE BASIS FOR THE MANUFACTURE OF SALE OF APPARATUS WITHOUT WRITTEN PERMISSION.		DRAWN: WAYNE ROBBINS	DATE: 11-28-05
			CHECKED:	DATE:
NorComp		SCALE: 1:1	SHEET 1 OF 3	REV 1
		DWG NO. 174-EYY-111RYY1		

DESCRIPTION: PCB LAYOUT - MALE & FEMALE

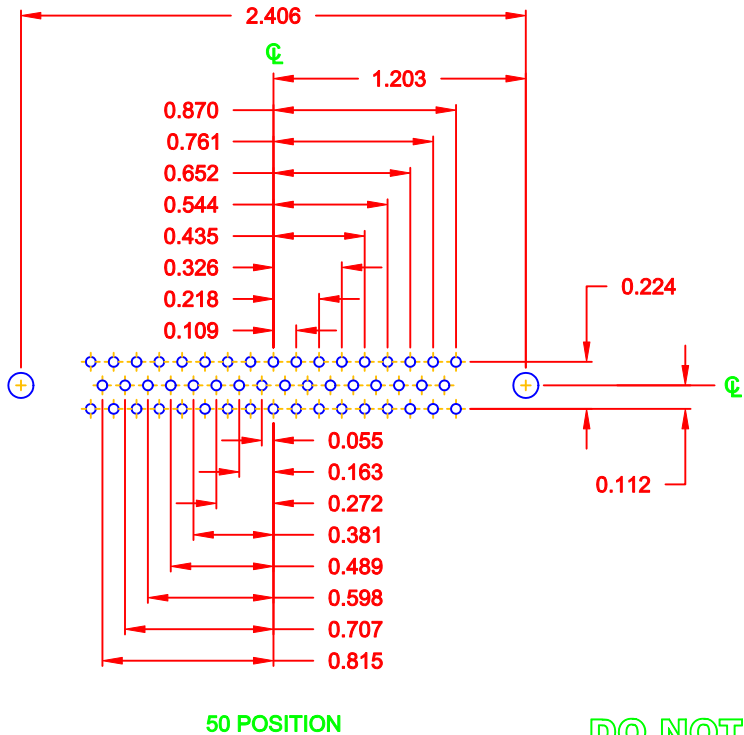
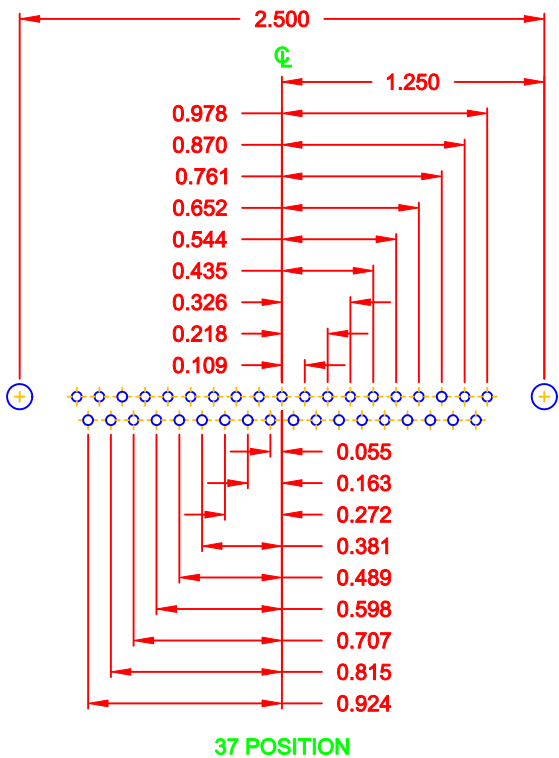
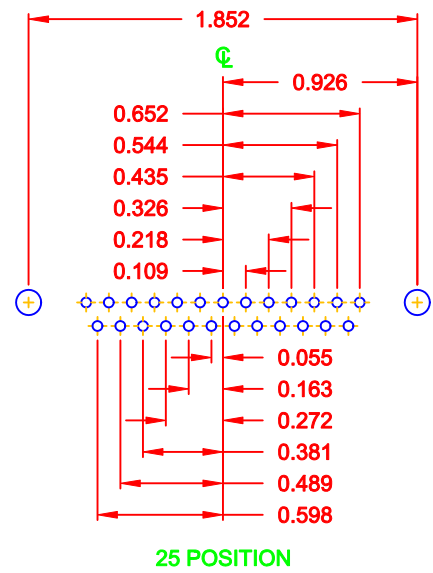
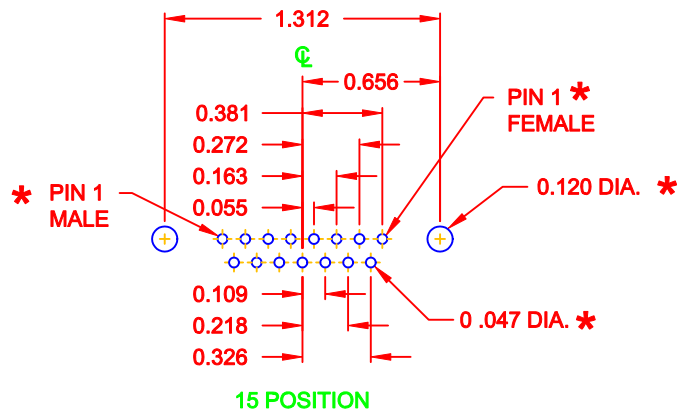
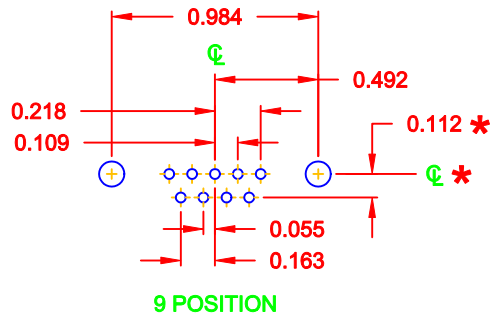

* TYP. ON ALL SIZES
UNLESS NOTED OTHERWISE

DO NOT SCALE FROM DRAWING

	THESE DRAWINGS AND SPECIFICATIONS ARE THE PROPERTY OF NorComp AND SHALL NOT BE REPRODUCED, COPIED OR USED AS THE BASIS FOR THE MANUFACTURE OF SALE OF APPARATUS WITHOUT WRITTEN PERMISSION.		DRAWN: C. SMITH	DATE: 03-08-06
			CHECKED:	DATE:
NorComp		SCALE: FULL	SHEET 2 OF 3	REV 1
		DWG NO. 174-EYY-111RYY1		

DESCRIPTION: CLINCH NUT HARDWARE

HARDWARE OPTIONS

REPLACE -YY IN LAST 3 DIGITS WITH OPTION CHOSEN

173/174 SERIES

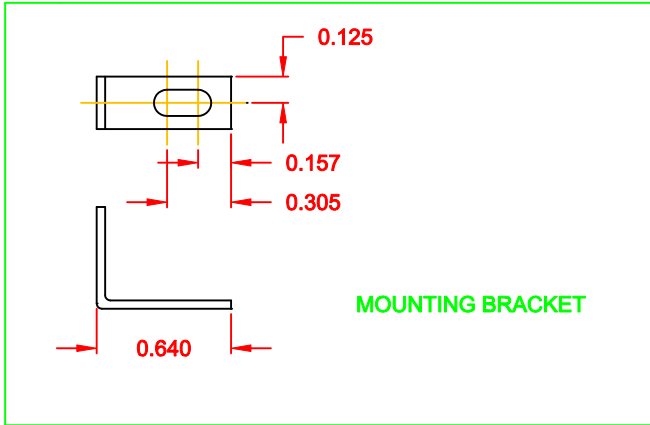

MOUNTING BRACKET

173 / 174 SERIES

- 14Y = SHORT BRACKET & 4-40 FEMALE HEX SOCKET
- 24Y = SHORT BRACKET & 4-40 SCREW

175/176 SERIES

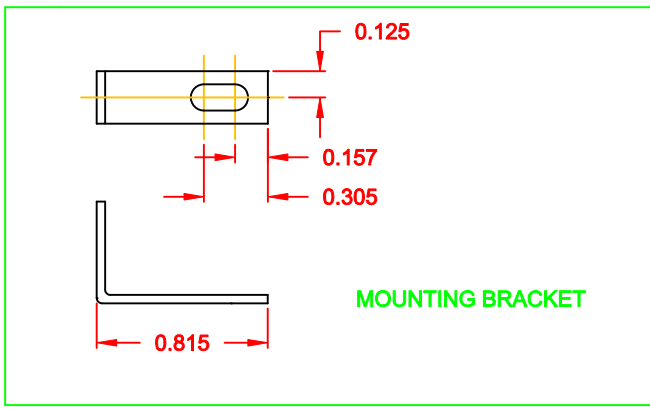

MOUNTING BRACKET

175 / 176 SERIES

- 15Y = LONG BRACKET & 4-40 FEMALE HEX SOCKET
- 25Y = SHORT BRACKET & 4-40 SCREW

DO NOT SCALE FROM DRAWING

MATERIAL: COLD ROLLED STEEL
 PLATING: CLEAR ZINC

	THESE DRAWINGS AND SPECIFICATIONS ARE THE PROPERTY OF NorComp AND SHALL NOT BE REPRODUCED, COPIED OR USED AS THE BASIS FOR THE MANUFACTURE OF SALE OF APPARATUS WITHOUT WRITTEN PERMISSION.		DRAWN: PAM JENKINS	DATE: 11-28-05
			CHECKED:	DATE:
NorComp		SCALE: 1 : 1	SHEET 3 OF 3	REV 1
		DWG NO. 174-EYY-111RYY1		