

NO. OF CIRCT.	DIM. "A"		DIM. "B"		ASSEMBLY MATERIAL NO. (STANDARD)	ASSEMBLY MATERIAL NO. (-50 OPT)
	mm	in	mm	in		
02	25.9	1.02	11.11	.438	386348302	386349002
03	37.0	1.46	22.23	.875	386348303	386349003
04	48.1	1.89	33.34	1.313	386348304	386349004
05	59.2	2.33	44.45	1.750	386348305	386349005
06	70.3	2.77	55.56	2.188	386348306	386349006
07	81.5	3.21	66.68	2.625	386348307	386349007
08	92.6	3.64	77.79	3.063	386348308	386349008
09	103.7	4.08	88.90	3.500	386348309	386349009
10	114.8	4.52	100.01	3.938	386348310	386349010
11	125.9	4.96	111.13	4.375	386348311	386349011
12	137.0	5.39	122.24	4.813	386348312	386349012
13	148.1	5.83	133.35	5.250	386348313	386349013
14	159.2	6.27	144.46	5.688	386348314	386349014
15	170.4	6.71	155.58	6.125	386348315	386349015
16	181.5	7.14	166.69	6.563	386348316	386349016
17	192.6	7.58	177.80	7.000	386348317	386349017
18	203.7	8.02	188.91	7.438	386348318	386349018
19	214.8	8.46	200.03	7.875	386348319	386349019
20	225.9	8.89	211.14	8.313	386348320	386349020

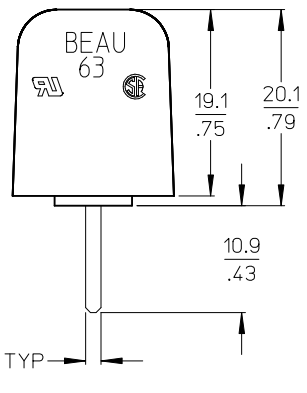
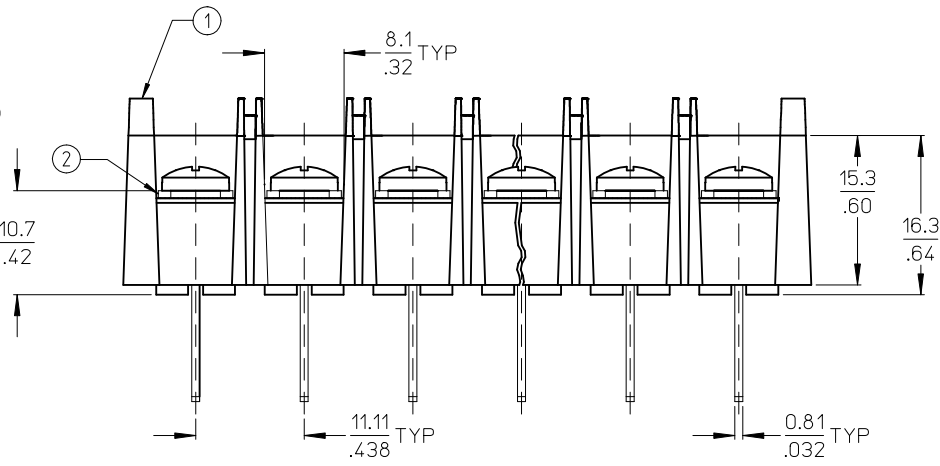
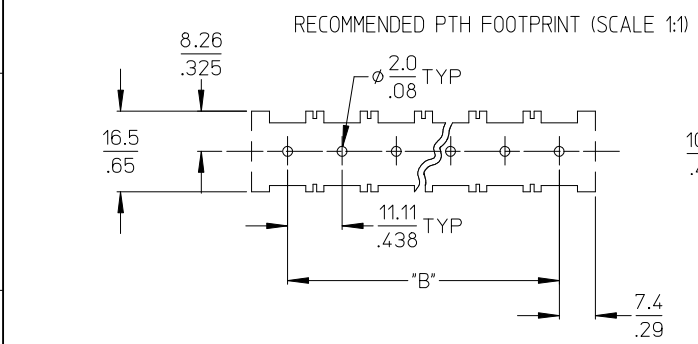
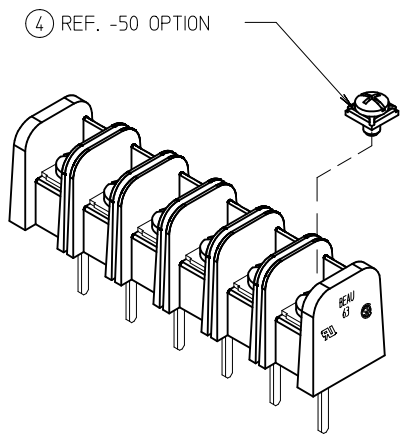
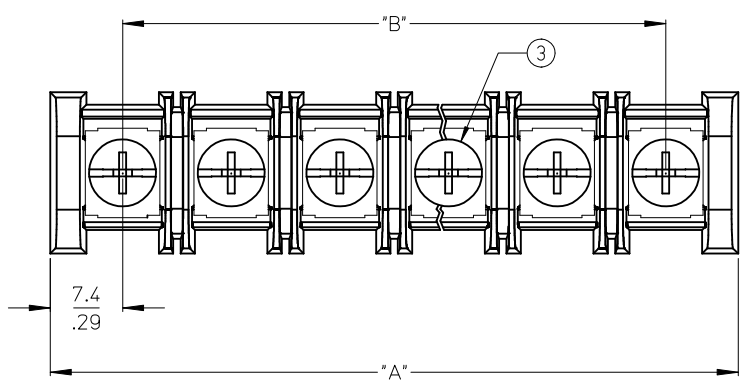

- NOTES:
1. MATERIAL: SEE TABLE
 2. "XX" REFERS TO THE QUANTITY OF CIRCUITS.
 3. MUST BE ROHS COMPLIANT.

ITEM	QTY.	DESCRIPTION	MATERIAL NO.	ENGINEERING NO.
4	XX	SCREW&WASHER, #6-32X.25, PAN, PH/SL, -50	STEEL	2504-9201-C220
3	XX	SCREW, #6-32X.25, BHD, PH/SL, STANDARD	STEEL	ZN, CLEAR CHROMATE
2	XX	TERMINAL, WIRE WRAP	BRASS	TIN PLATED
1	1	HOUSING, SR BTS, PC, CS, NO MTG.	POLYESTER (PBT)	BLACK

RELEASED EC NO: WNA2010-0720 DRWN: JENCINAS 2010/05/25 CHKD: CLYORK 2010/05/25 APPR: JMACNEIL 2010/06/15	QUALITY SYMBOLS ▽=0 ▽=0	GENERAL TOLERANCES (UNLESS SPECIFIED) mm INCH 4 PLACES ± --- ± --- 3 PLACES ± --- ± .005 2 PLACES ± 0.13 ± .010 1 PLACE ± 0.3 ± --- ANGULAR ± 2°	DIMENSION STYLE MM/IN DRAWN BY DATE JENCINAS 2010/05/25 CHECKED BY DATE CLYORK 2010/05/25 APPROVED BY DATE JMACNEIL 2010/06/15	SCALE 2:1 DESIGN UNITS INCH THIRD ANGLE PROJECTION	
		DRAFT WHERE APPLICABLE MUST REMAIN WITHIN DIMENSIONS	SEE CHART MATERIAL NO.	MOLEX INCORPORATED DOCUMENT NO. SD-38634-003	SHEET NO. 1 OF 1
		THIS DRAWING CONTAINS INFORMATION THAT IS PROPRIETARY TO MOLEX INCORPORATED AND SHOULD NOT BE USED WITHOUT WRITTEN PERMISSION			
		THIS DRAWING CONTAINS INFORMATION THAT IS PROPRIETARY TO MOLEX INCORPORATED AND SHOULD NOT BE USED WITHOUT WRITTEN PERMISSION			