

2.1V(or 2.5V) to 5.5V, 1.5A 1ch Boost Converter with Integrated FET

BD8152FVM BD8158FVM

General Description

BD8152FVM and BD8158FVM are 1-Channel boost converter which uses low voltage FET. The input voltage is 2.5V to 5.5V for BD8152FVM and 2.1V to 5.5V for BD8158FVM achieving a low power consumption. The high accuracy feedback voltage ($\pm 1\%$) is established and the brightness dispersion of TFT-LCD panel is suppressed.

Key Specifications

- Input Voltage Range: BD8152FVM 2.5V to 5.5V
BD8158FVM 2.1V to 5.5V
- Switching Frequency: 600 kHz/1,200 kHz
- Integrated FET R_{ON} 250m Ω (Typ)
- Feedback Voltage: 1.245 \pm 1%
- Ultra-Low Current Consumption: 0 μ A (Typ)
- Operating Temperature Range:
BD8152FVM -40°C to +85°C
BD8158FVM -40°C to +125°C

Features

- Current Mode PWM System
- Built-In Under-Voltage Lockout Protection Circuit
- Built-In Over-Current Protection Circuit
- Built-In Thermal Shutdown Circuit

Applications

- Panels for the Satellite Navigation System
- Laptop PC(7 to17 inches)
- TFT-LCD Panels

Package

W (Typ) x D (Typ) x H (Max)

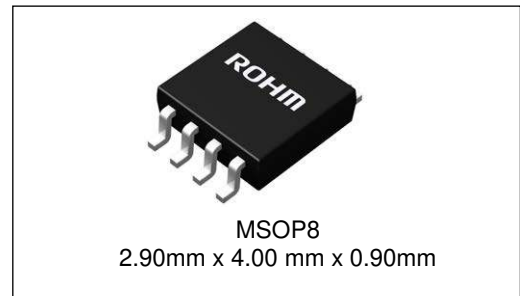

Typical Application Circuit

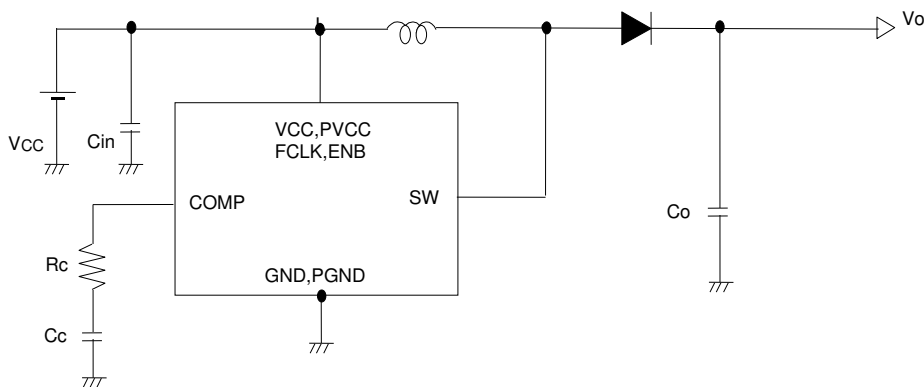

Figure 1. Typical Application Circuit

Pin Configuration

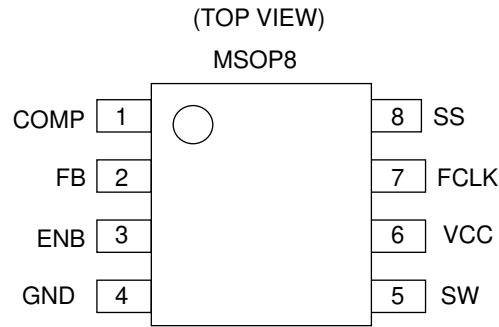

Figure 2. Pin Configuration

Pin Description

Pin No.	Pin Name	Function
1	COMP	Error amp output
2	FB	Error amp inversion input pin
3	ENB	Control input pin
4	GND	Ground pin
5	SW	N-Channel power FET drain output
6	VCC	Power supply input pin
7	FCLK	Frequency switching pin
8	SS	Soft-start current output pin

Block Diagram

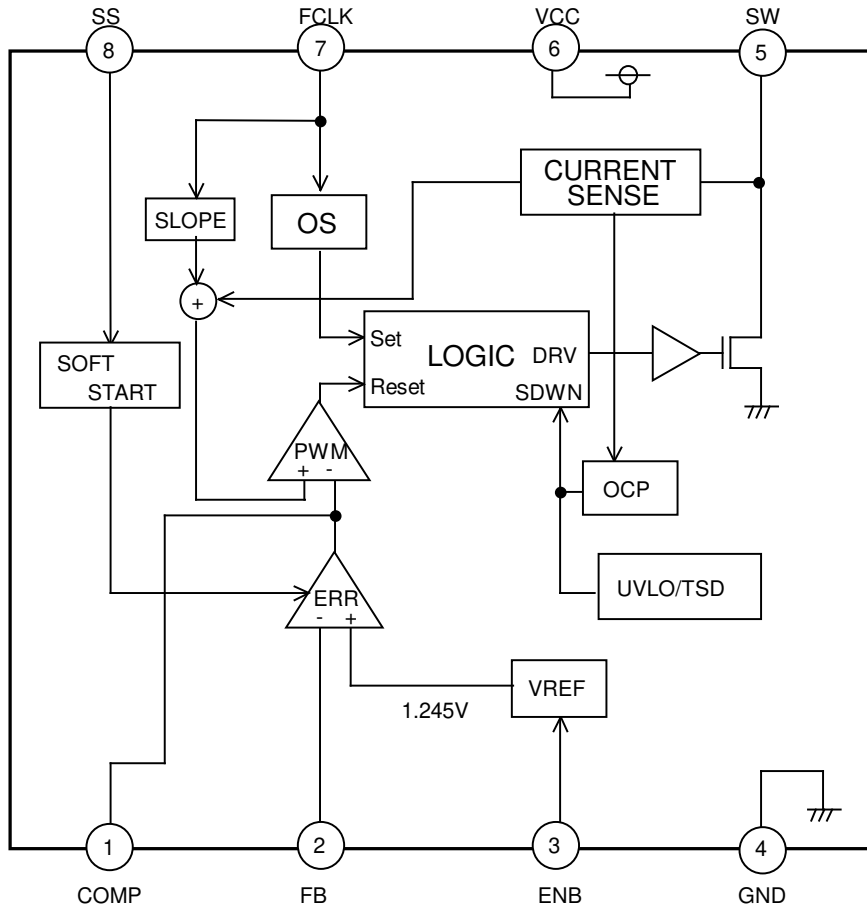

Figure 3. Block Diagram

Absolute Maximum Ratings (Ta = 25°C)

Parameter	Symbol	Limit	Unit
Power Supply Voltage Range	V _{CC}	7	V
Power Dissipation	P _d	0.58 ^(Note1)	W
Storage Temperature Range	T _{stg}	-55 to +150	°C
Switch Pin Current	I _{sw}	1.5 ^(Note2)	A
Switch Pin Voltage	V _{sw}	15	V
Maximum Junction Temperature	T _{jmax}	150	°C

(Note 1) Reduced by 4.7 W/°C over 25°C, when mounted on a glass epoxy board (70 mm x 70 mm x 1.6 mm).

(Note 2) Must not exceed P_d.

Caution: Operating the IC over the absolute maximum ratings may damage the IC. The damage can either be a short circuit between pins or an open circuit between pins. Therefore, it is important to consider circuit protection measures, such as adding a fuse, in case the IC is operated over the absolute maximum ratings.

Recommended Operating Conditions (Ta = 25°C)

Parameter		Symbol	Limit			Unit
			Min	Typ	Max	
Power Supply Voltage Range	BD8152FM	V _{CC}	2.5	3.3	5.5	V
	BD8158FM		2.1	2.5	4.0(5.5) ^(Note3)	V
Switch Current		I _{sw}	-	-	1.4	A
Switch Pin Voltage Range		V _{sw}	-	-	14	V
Operating Temperature Range	BD8152FM	T _{opr}	-40	-	+85	°C
	BD8158FM		-40	-	+125	°C

(Note3) Specified at 600kHz switching operation.

Electrical Characteristics

BD8152FVM (Unless otherwise specified, Ta = 25°C; V_{CC} = 3.3V; V_{ENB} = 3.3V)

Parameter	Symbol	Limit			Unit	Conditions
		Min	Typ	Max		
[Triangular Waveform Oscillator]						
Oscillating Frequency 1	f _{OSC1}	540	600	660	kHz	V _{FCLK} = 0V
Oscillating Frequency 2	f _{OSC2}	1.08	1.20	1.32	MHz	V _{FCLK} = V _{CC}
[Over-Current Protection Circuit]						
Over-Current Limit	I _{sw}	-	2	-	A	
[Soft-Start Circuit]						
SS Source Current	I _{SO}	6	10	14	μA	V _{SS} = 0.5V
[Under-Voltage Lockout Protection Circuit]						
OFF Threshold Voltage	V _{UTOFF}	2.1	2.2	2.3	V	
ON Threshold Voltage	V _{UTON}	2.0	2.1	2.2	V	
[Error Amp]						
Input Bias Current	I _B	-	0.1	0.5	μA	
Feedback Voltage	V _{FB}	1.232	1.245	1.258	V	Buffer
[Output]						
ON-Resistance	R _{ON}	-	250	380	mΩ	^(Note 4) I _{sw} = 1 A
Max Duty Ratio	D _{MAX}	72	80	88	%	R _L = 100 Ω
[ENB]						
ENB ON Voltage	V _{ON}	V _{CC} ×0.7	V _{CC}	-	V	
ENB OFF Voltage	V _{OFF}	-	0	V _{CC} ×0.3	V	
[Overall]						
Standby Current	I _{STB}	-	0	10	μA	V _{ENB} = 0 V
Average Consumption Current	I _{CC}	-	1.2	2.4	mA	No Switching

(Note 4) Design guarantee (No total shipment inspection is made.)

Electrical Characteristics – continued

BD8158FVM (Unless otherwise specified, $T_a = 25^\circ\text{C}$; $V_{CC} = 2.5\text{V}$; $V_{ENB} = 2.5\text{V}$)

Parameter	Symbol	Limit			Unit	Conditions
		Min	Typ	Max		
[Triangular Waveform Oscillator]						
Oscillating Frequency 1	f_{OSC1}	480	600	720	kHz	$V_{FCLK} = 0\text{V}$
Oscillating Frequency 2	f_{OSC2}	0.96	1.20	1.44	MHz	$V_{FCLK} = V_{CC}$
[Over-Current Protection Circuit]						
Over-Current Limit	I_{SW}	-	2	-	A	
[Soft-Start Circuit]						
SS Source Current	I_{SO}	6	10	14	μA	$V_{SS} = 0.5\text{V}$
[Under-Voltage Lockout Protection Circuit]						
OFF Threshold Voltage	V_{UTOFF}	1.7	1.8	1.9	V	
ON Threshold Voltage	V_{UTON}	1.6	1.7	1.8	V	
[Error Amp]						
Input Bias Current	I_B	-	0.1	0.5	μA	
Feedback Voltage	V_{FB}	1.232	1.245	1.258	V	Buffer
[Output]						
ON-Resistance	R_{ON}	-	250	-	$\text{m}\Omega$	(Note 5) $I_{SW} = 1\text{A}$
Max Duty Ratio	D_{MAX}	-	85	-	%	$R_L = 100\ \Omega$
[ENB]						
ENB ON Voltage	V_{ON}	$V_{CC} \times 0.7$	V_{CC}	-	V	
ENB OFF Voltage	V_{OFF}	-	0	$V_{CC} \times 0.3$	V	
[Overall]						
Standby Current	I_{STB}	-	0	10	μA	$V_{ENB} = 0\text{V}$
Average Consumption Current	I_{CC}	-	1.2	2.4	mA	No Switching

(Note 5) Design guarantee (No total shipment inspection is made.)

Typical Performance Curves

(Unless otherwise specified, Ta = 25°C)

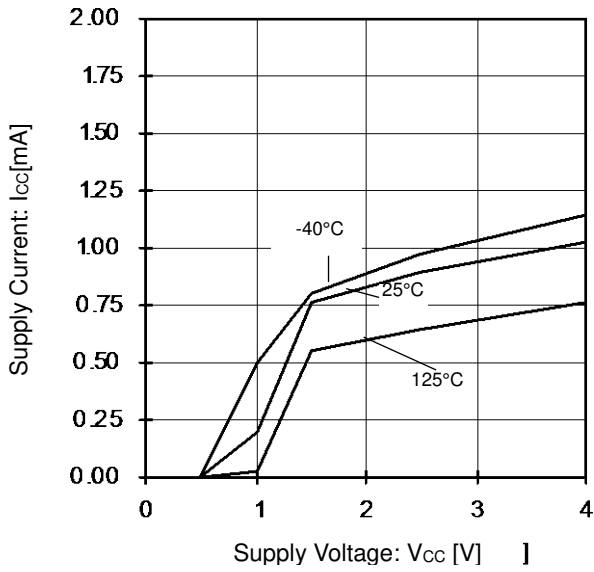

Figure 4. Supply Current vs Supply Voltage

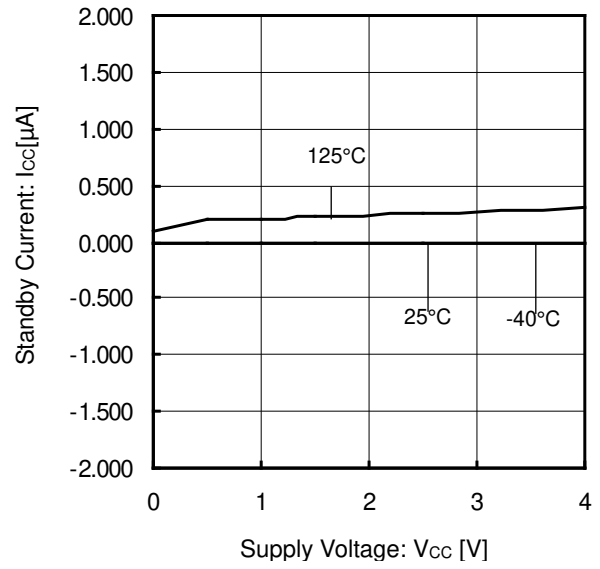

Figure 5. Standby Current vs Supply Voltage

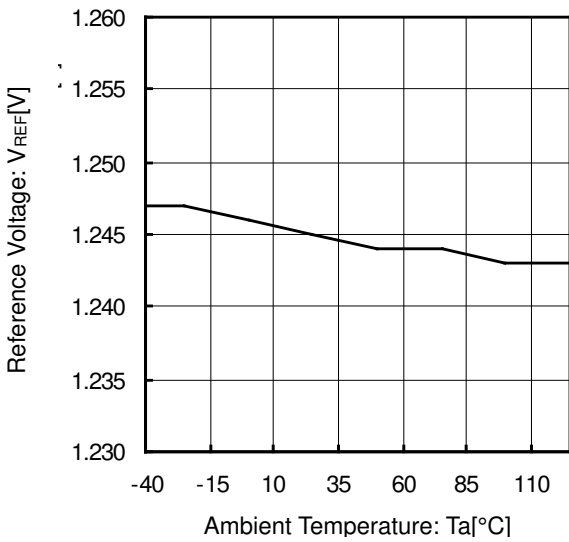

Figure 6. Reference Voltage vs Temperature

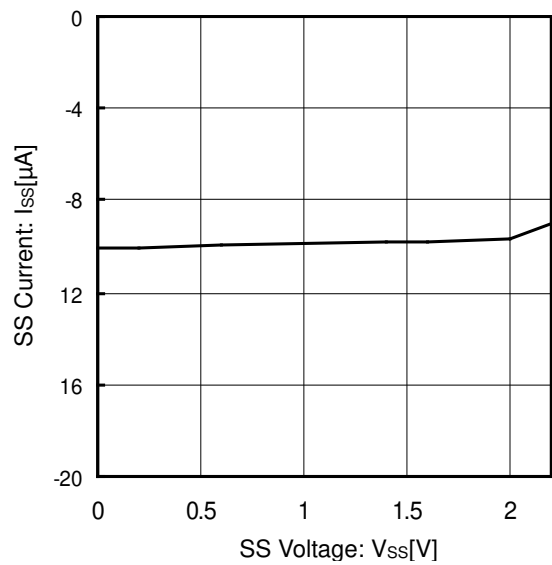

Figure 7. SS Current vs SS Voltage

Typical Performance Curves - continued

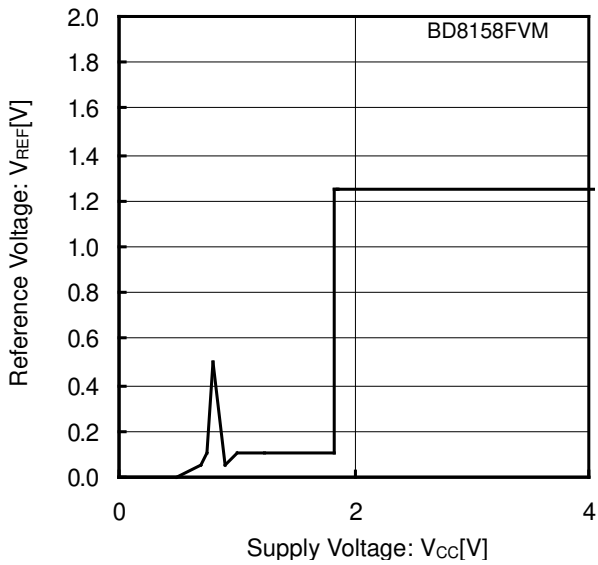

Figure 8. Reference Voltage vs Supply Voltage

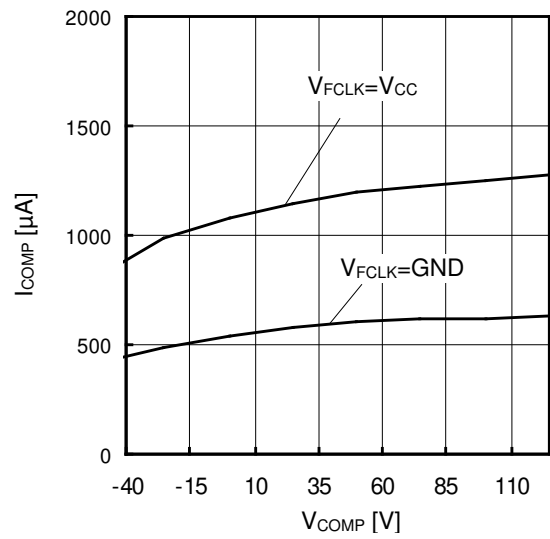

Figure 9. I_{COMP} vs V_{COMP}

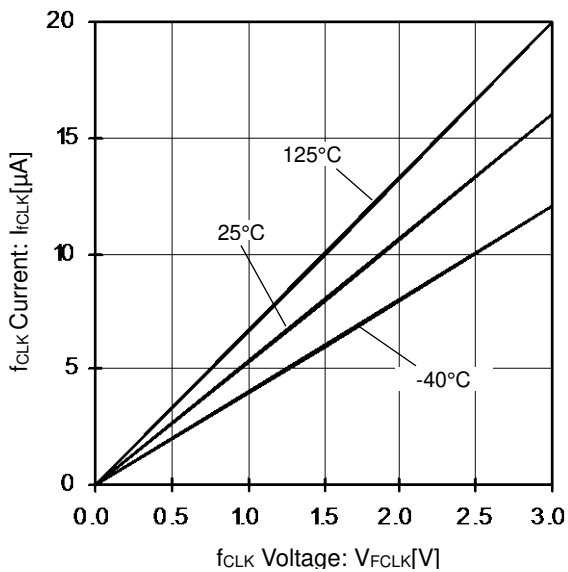

Figure 10. f_{CLK} Pin Current vs f_{CLK} Voltage

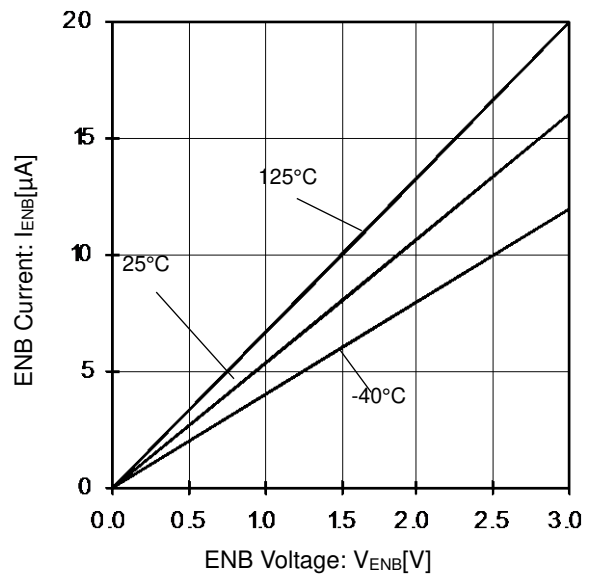

Figure 11. ENB Pin Current vs ENB Voltage

Typical Performance Curves - continued

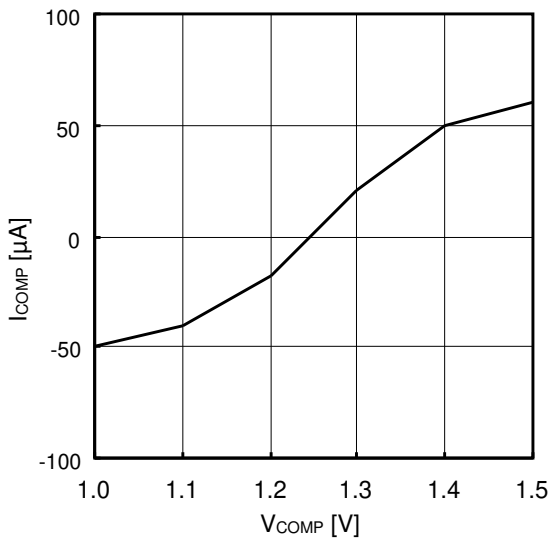

Figure 12. I_{COMP} vs V_{COMP}

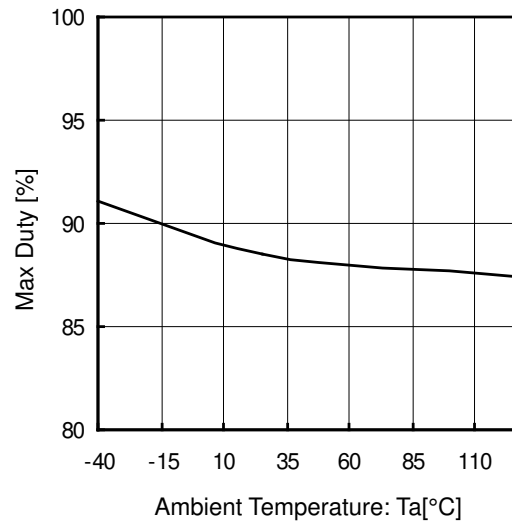

Figure 13. Max Duty vs Temperature

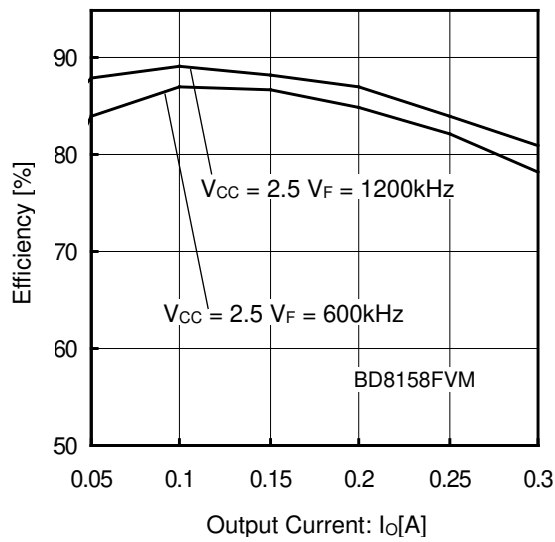

Figure 14. Efficiency vs Output Current (V_{CC}=2.5V)

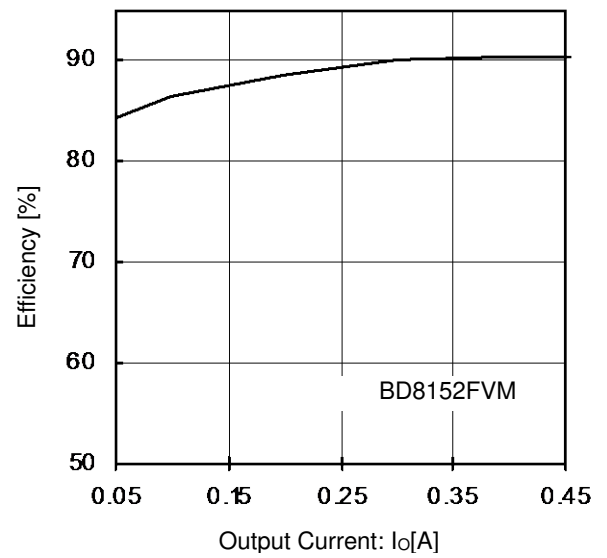

Figure 15. Efficiency vs Output Current (V_{CC}=5V)

Typical Performance Curves - continued

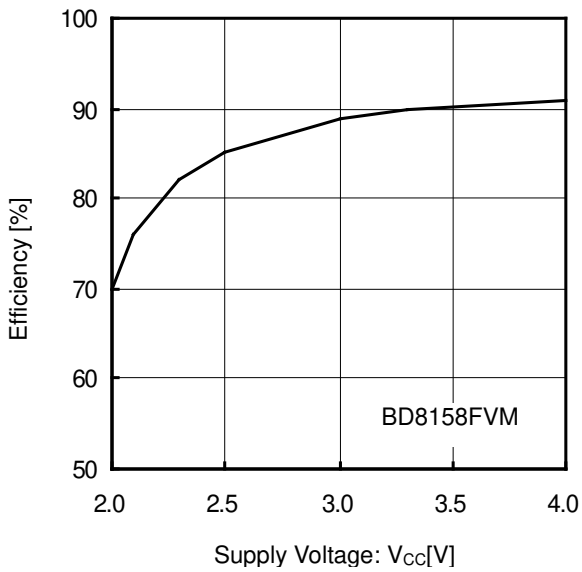

Figure 16. Efficiency vs Supply Voltage

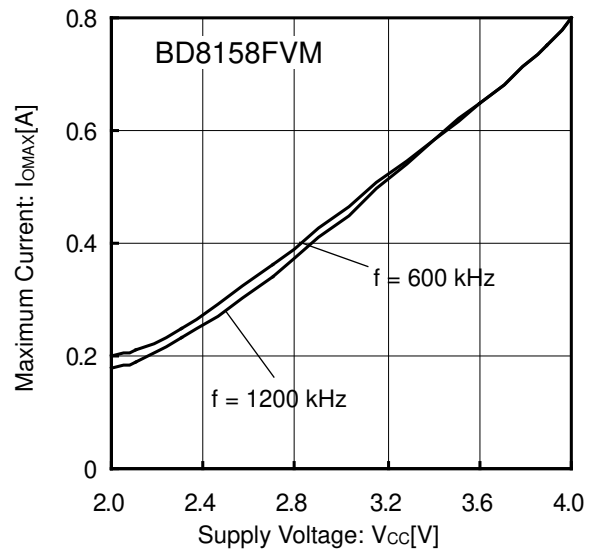

Figure 17. Maximum Current vs Supply Voltage

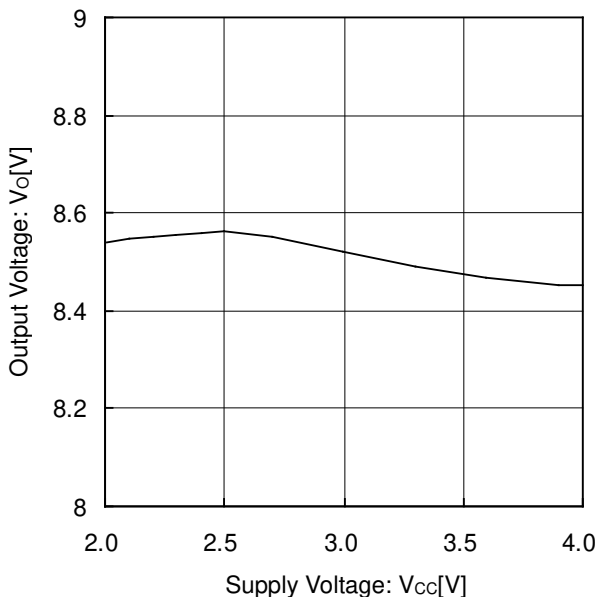

Figure 18. Output Voltage vs Supply Voltage (Line Regulation)

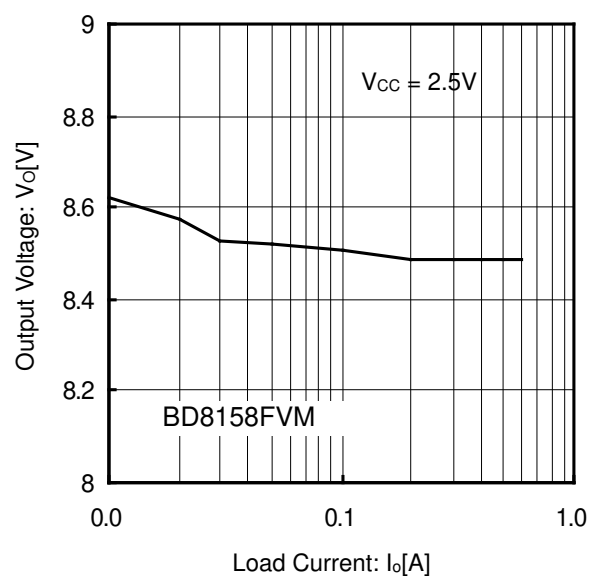

Figure 19. Output Voltage vs Load Current (Load Regulation 1)

Typical Performance Curves - continued

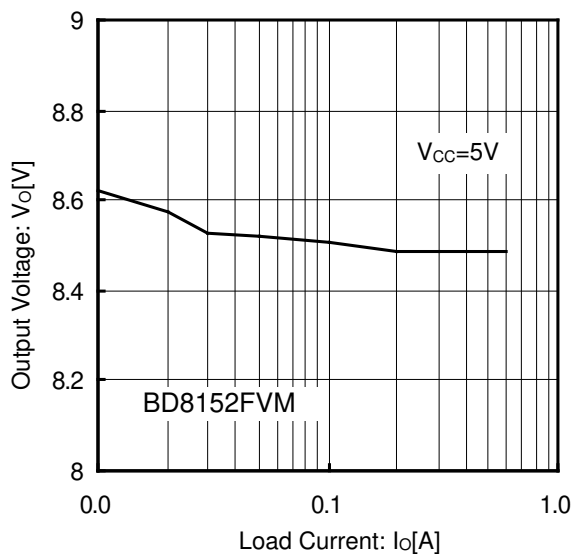

Figure 20. Output Voltage vs Load Current (Load Regulation 2)

Typical Waveforms

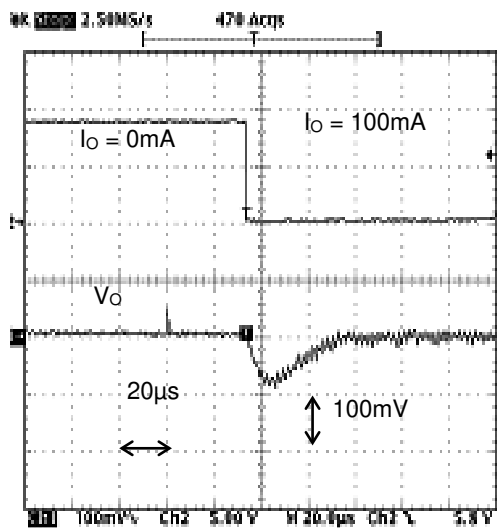
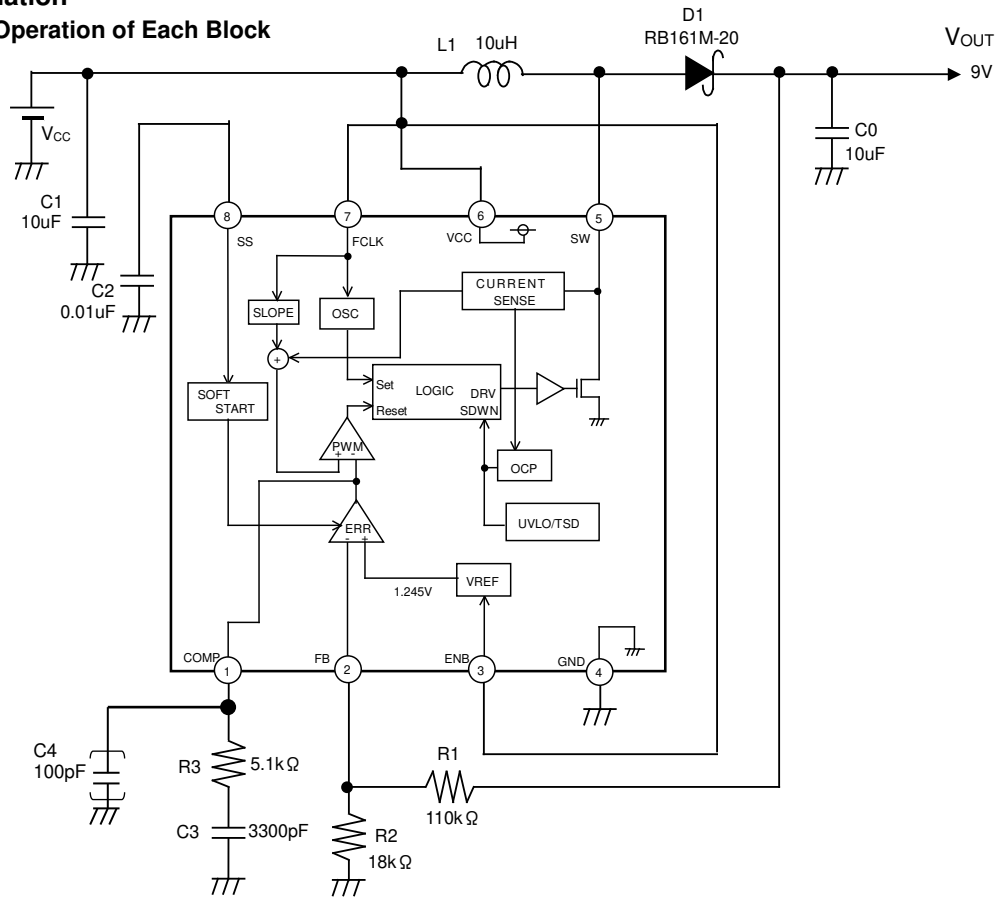

Figure 21. Load Response Waveform

Application Information

1. Description of Operation of Each Block



- (1) Error Amp (ERR)
This is the circuit used to compare the reference voltage 1.245V(Typ) and the feedback voltage of output. Switching duty is decided by the COMP pin voltage which is connected to the error amp output. During start-up, since the soft start is operated by the SS pin voltage, the COMP pin voltage is limited to SS pin voltage.
- (2) Oscillator (OSC)
This block generates the oscillating frequency. It is possible to select 600kHz/1.2MHz(Typ) via f_{CLK} pin.
- (3) SLOPE
This block generates the triangular waveform from the clock generated by OSC. Generated triangular waveform is fed to the PWM comparator.
- (4) PWM
The output COMP voltage of the error amp and the triangular waveform of the SLOPE block are compared to set the switching duty. Since the switching duty is limited by the maximum duty ratio which is set internally, it does not become 100%.
- (5) Reference Voltage (VREF)
This block generates the internal reference voltage of 1.245V(Typ).
- (6) Protection Circuit (UVLO/TSD)
UVLO (under-voltage lockout protection circuit) shuts down the circuit when the voltage is equal or lower than 2.2V(Typ) for BD8152FVM and 1.8V(Typ) for BD8158FVM. Thermal shutdown circuit shuts down IC's operation at 175°C(Typ) and recovers at 160°C (Typ).
- (7) Over-Current Protection Circuit (OCP)
Current flowing to the power FET is detected by voltage at the CURRENT SENSE and the Over-Current protection operates at 3A(Typ). When the Over-Current protection activates, the switching is turned OFF and the SS pin capacity is discharged.
- (8) Soft-Start Circuit
Since the output voltage rises gradually while restricting the current at the time of startup, it is possible to prevent the output voltage overshoot or the inrush current.

2. Timing Chart

Startup sequence

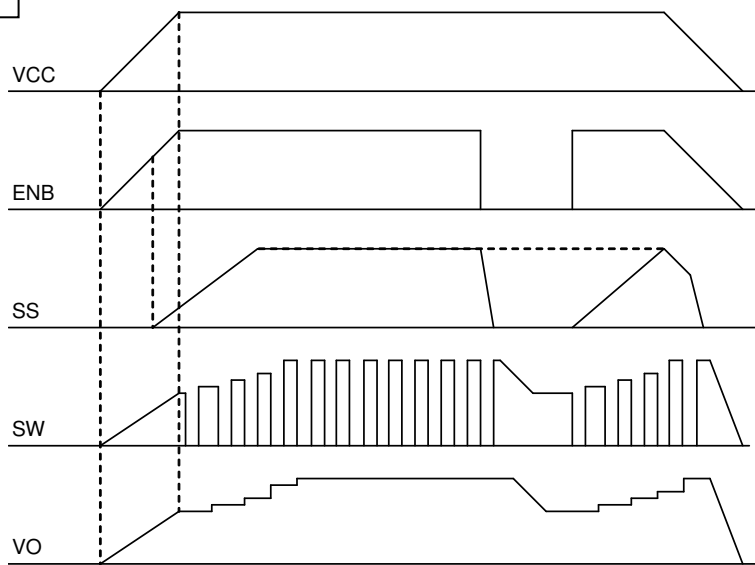

Figure 22. Startup Sequence Waveform

Over-Current protection operation

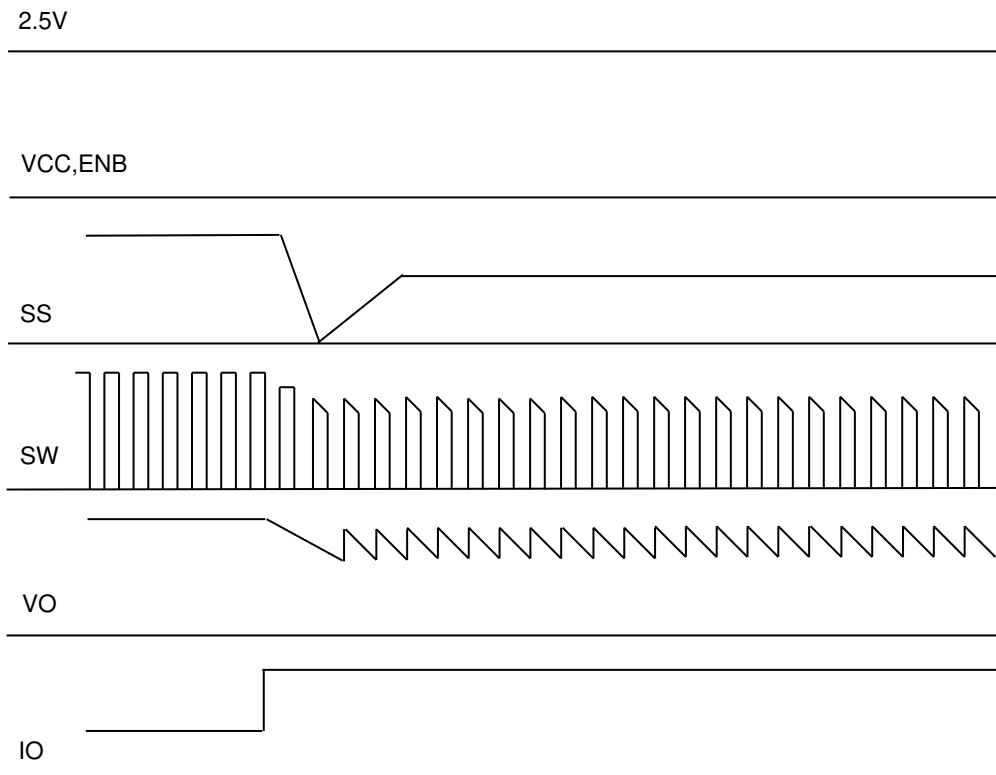

Figure 23. Over-Current Protection Operating Waveform

3. Selecting Application Components

(1) Setting the Output L Constant

The coil L to use for output is decided by the rating current I_{LR} and input current maximum value I_{INMAX} of the coil.

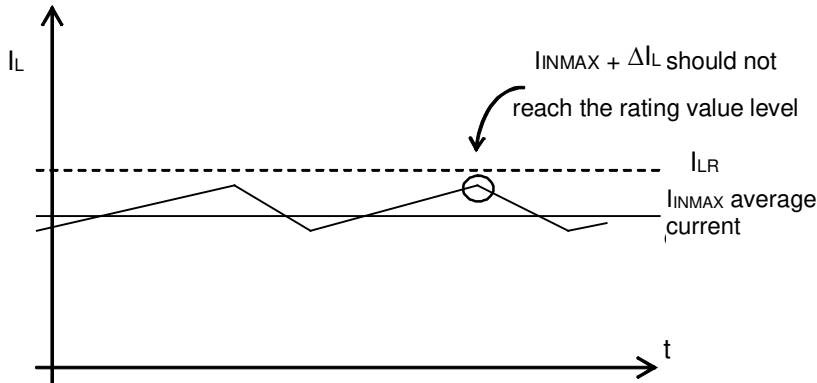

Figure 24. Coil Current Waveform

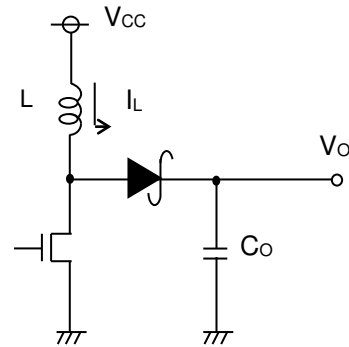

Figure 25. Output Application Circuit Diagram

Adjust coil L so that $I_{INMAX} + \Delta I_L$ does not reach the rating current value I_{LR} . At this time, ΔI_L can be obtained by the following equation.

$$\Delta I_L = \frac{1}{L} V_{CC} \times \frac{V_O - V_{CC}}{V_O} \times \frac{1}{f} \quad [A]$$

where:

f is the switching frequency.

Set with sufficient margin because the coil L value may have the dispersion of approx. $\pm 30\%$. If the coil current exceeds the rating current I_{LR} of the coil, it may damage the IC internal element.

BD8152FVM and BD8158FVM use a current mode DC/DC converter control and an optimized design at the coil value. The following coil values are recommended considering the power efficiency, response and safety. When the coil value selected is out of this range, the stable continues operation is not guaranteed such as the switching waveform becomes irregular. Please pay attention to it.

Switching frequency: $L = 10 \mu\text{H}$ to $22 \mu\text{H}$ at 600 kHz

Switching frequency: $L = 4.7 \mu\text{H}$ to $15 \mu\text{H}$ at 1,200 kHz

(2) Setting the Output Capacitor

For the capacitor C to use for the output, select the capacitor which has the larger ripple voltage (V_{PP}) and drop voltage allowance value at the time of sudden load change. Output ripple voltage is decided by the following equation.

$$\Delta V_{PP} = I_{LMAX} \times R_{ESR} + \frac{1}{fC_o} \times \frac{V_{CC}}{V_o} \times \left(I_{LMAX} - \frac{\Delta I_L}{2} \right) \quad [V]$$

where:

f is the switching frequency

Perform setting so that the voltage is within the allowable ripple voltage range.

For the drop voltage during sudden load change (V_{DR}), please perform a rough calculation using the following equation.

$$V_{DR} = \frac{\Delta I}{C_o} \times 10 \mu \text{ sec} \quad [V]$$

However, $10 \mu\text{s}$ is the rough calculation value of the DC/DC response speed. Please set the capacitance considering the sufficient margin so that these two values are within the standard value range.

(3) Selecting the Input Capacitor

Since the peak current flows between the input and output at the DC/DC converter, a capacitor is required at the input side. For this reason, the low ESR capacitor is recommended as an input capacitor which has the value more than $10 \mu\text{F}$ and less than $100 \text{ m}\Omega$ ESR. If a capacitor selected is out of this range, the excessive ripple voltage will occur on the input voltage hence it may cause the malfunction of IC.

However, these conditions may vary according to the load current, input voltage, output voltage, inductance and switching frequency. Be sure to perform the margin check using the actual product.

- (4) Selecting the Output Rectification Diode
Schottky barrier diode is recommended as the rectification diode to be used at the DC/DC converter output stage. Select the diode paying attention to the max inductor current and max output voltage.

Max Inductor Current	$I_{INMAX} + \Delta I_L$	<	Current rating of diode
Max Output Voltage	V_{OMAX}	<	Voltage rating of diode

Since each parameter has 30% to 40% of dispersion, be sure to design with sufficient margins.

- (5) Design of the Feedback Resistor Constant
Refer to the following equation to set the feedback resistor. As the setting range, 10kΩ to 330kΩ is recommended. If the resistor is set to 10kΩ or lower, it causes the reduction of power efficiency. If it is set to 330kΩ or larger, the offset voltage becomes larger with respect to the input bias current 0.4μA(Typ) in the internal error amp.

$$V_o = \frac{R_8 + R_9}{R_9} \times 1.245 \quad [V]$$

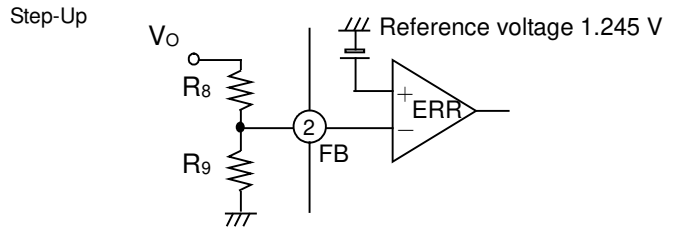

Figure 26. Feedback Resistor Setting

- (6) Setting the Soft-Start Time
Soft-start is required to prevent the coil current from increasing and the overshoot of the output voltage at the time of startup. Figure 27. shows the relation between the capacitance and soft start time. Please refer to it to set the capacitance.

For the capacitance value, 0.001μF to 0.1μF is recommended. If the capacitance value is set to 0.001μF or lower, overshoot may occur on the output voltage. If the capacitance value is set to 0.1μF or larger, excessive back current flow may occur in the internal parasitic elements when the power is turned OFF and it may damage the IC. When the capacitor used is 0.1μF or larger, be sure to insert a diode to VCC in series, or a bypass diode between the SS pin and VCC.

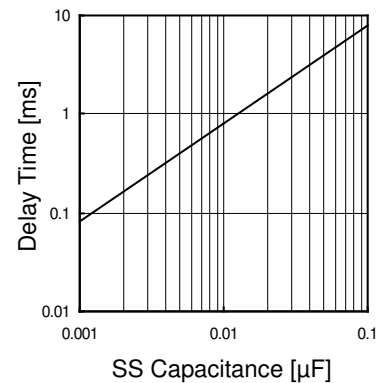

Figure 27. SS Pin Capacitance vs Delay Time

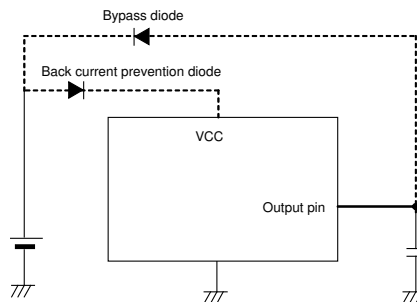

Figure 28. Bypass Diode Example

When there is startup sequence with other power supplies, be sure to use the high accuracy product (such as X5R). Soft start time may vary according to the input voltage, output voltage, loads, coils and output capacity. Be sure to verify the operation using the actual product.

- (7) Setting the ENB Pin
When the ENB pin is set to High, the internal circuit becomes active and the DC/DC converter starts its operation. When it is set to Low, the shut down function activates and all circuits will be turned OFF.
- (8) Setting the Frequency by FCLK
It is possible to change the switching frequency by setting the FCLK pin to High or Low. When it is set to Low, the IC operates at 600kHz(Typ). When it is set to High, the IC operates at 1,200kHz(Typ).

(9) Setting R_C , C_C of the Phase Compensation Circuit

In the current mode control, since the coil current is controlled, a pole (phase lag) made by the CR filter composed of the output capacitor and load resistor will be created in the low frequency range, and a zero (phase lead) by the output capacitor and ESR of capacitor will be created in the high frequency range. In this case, cancel the pole of the power amplifier. It is easy to compensate by adding the zero point with C_C and R_C to the output from the error amp as shown in the illustration.

Open loop gain

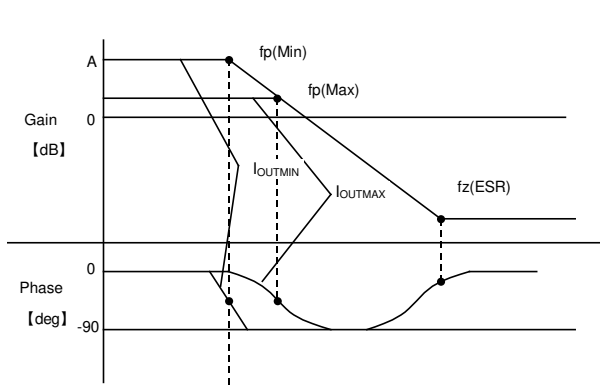

$$f_P = \frac{1}{2\pi \times R_O \times C_O} \quad [Hz]$$

$$f_Z (ESR) = \frac{1}{2\pi \times ESR \times C_O} \quad [Hz]$$

Pole at the power amplification stage

When the output current decreases, the load resistance R_o increases and the pole frequency decreases.

$$f_P (Min) = \frac{1}{2\pi \times R_{O\ MAX} \times C_O} \quad [Hz] \leftarrow \text{At light-load}$$

$$f_P (Max) = \frac{1}{2\pi \times R_{O\ MIN} \times C_O} \quad [Hz] \leftarrow \text{At heavy-load}$$

Zero at the power amplification stage

When the output capacitor is set larger, the pole frequency is decreased but the zero frequency will not change. (This is because the capacitor ESR becomes 1/2 when the capacitor becomes 2 times.)

$$f_P (Amp.) = \frac{1}{2\pi \times R_C \times C_C} \quad [Hz]$$

Error amp phase compensation

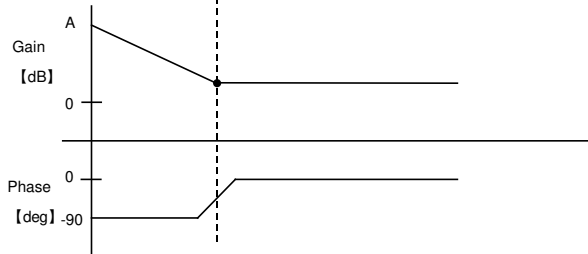

Figure 29. Gain vs Phase

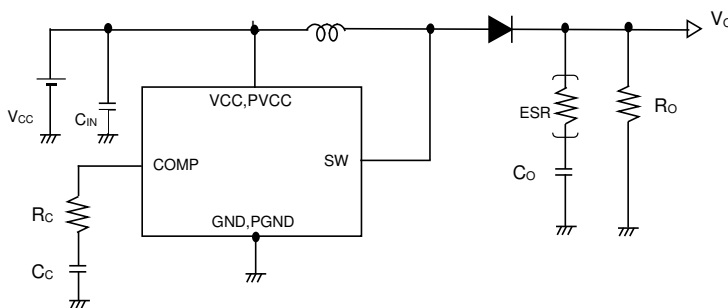

Figure 30. Application Circuit Diagram

It is possible to achieve the stable feedback loop by canceling the pole $f_p (Min)$, which is created by the output capacitor and load resistor, with CR zero compensation of the error amp as shown below.

$$f_Z (Amp.) = f_P (Min)$$

$$\longrightarrow \frac{1}{2\pi \times R_C \times C_C} = \frac{1}{2\pi \times R_{O\ MAX} \times C_O} \quad [Hz]$$

For the setting range of the resistor, 1kΩ to 10kΩ is recommended. When the resistor is set to 1kΩ or lower, the effect of phase compensation becomes low and it may cause the oscillation of output voltage. When it is set to 10kΩ or larger, the COMP pin becomes Hi-Z and the switching noise becomes easy to occur. Therefore the stable switching pulse cannot be generated and the irregular ripple voltage may be generated on the output voltage.

For the setting range of the capacitance, 3,300pF to 10,000pF is recommended. When the capacitance is set to 3,300pF or lower, the irregular ripple voltage may be generated on the output voltage due to the effect of switching noise. When it is set to 10,000pF or larger, the response becomes worse and the output voltage fluctuation becomes large. Accordingly it may require the output capacitor which is larger than the necessary value.

4. Application Examples

Although ROHM is sure that the application examples are recommendable ones, further check the characteristics of components that require high precision before using them. When using the circuit and modifying the externally connected circuit constant, be sure to decide allowing sufficient margins considering the tolerance values of external parts as well as our IC including not only the static but also the transient characteristic. For the patent, we have not acquired the sufficient confirmation. Please acknowledge the status.

(1) When the charge pump is removed from the DC/DC converter to make it 3-Channel output mode:

It is possible to create the charge pump by using the switching operation of DC/DC converter. When the application shown in the following diagram is used, 1-Channel DC/DC converter output, 1-Channel positive side charge pump and 1-Channel negative side charge pump can be output as a total of 3-Channels.

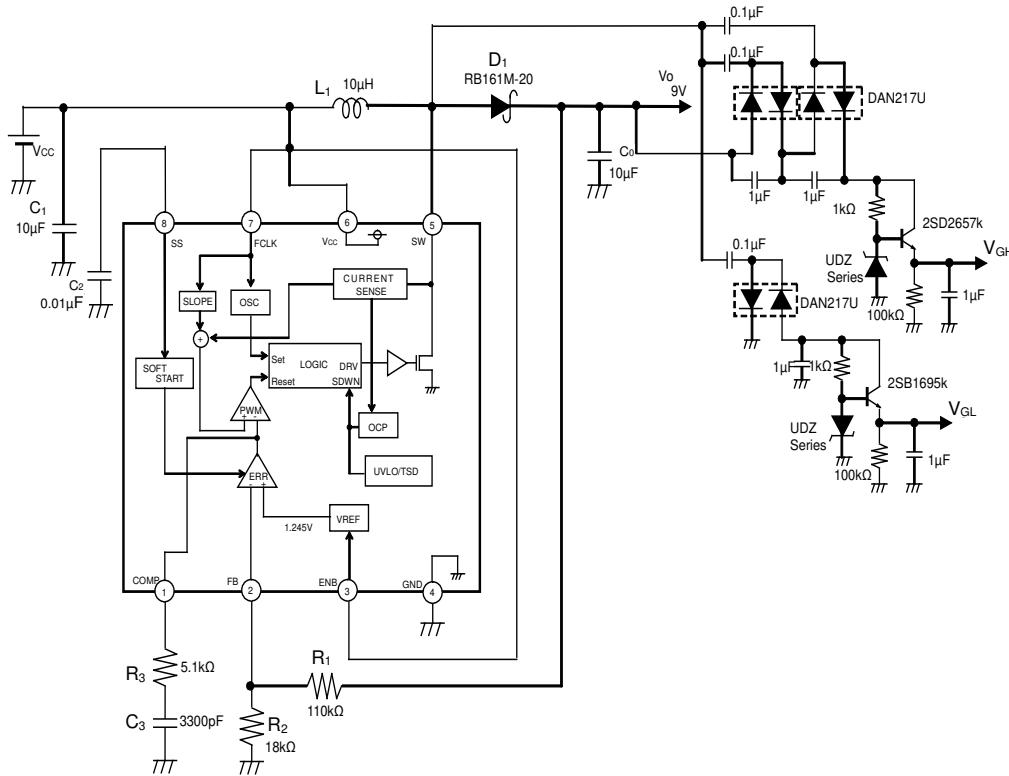

Figure 31. 3ch Application Circuit Diagram Example

- (2) When the output voltage is set to 0V:
 Since the switch does not exist between the input and output in the application using the boost type DC/DC converter, the output voltage is generated even if the IC is turned OFF. When it is intended to maintain the output voltage 0V until IC operates, insert the switch as shown in the following circuit diagram.

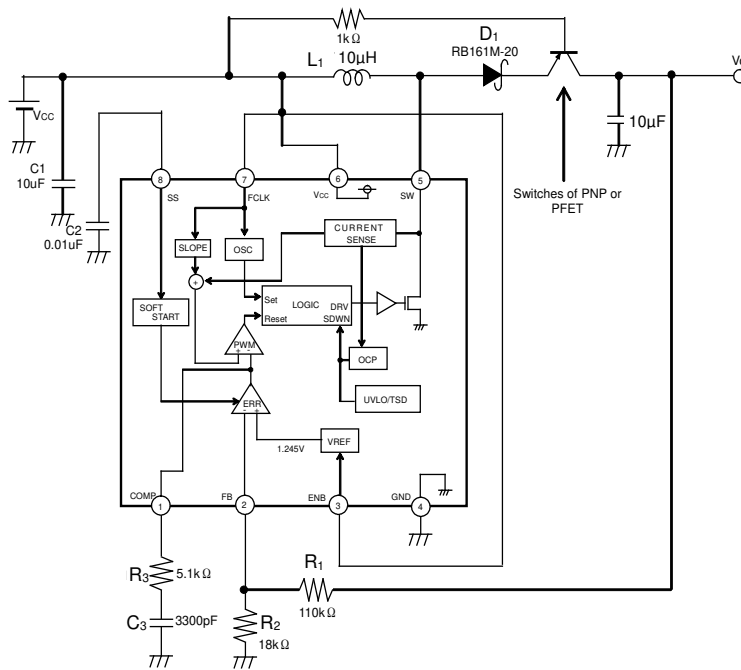

Figure 32. Switch Application Circuit Diagram Example

- (3) When the circuit is intended to operate at the lower voltage than the IC's operating range:
 Although the recommended operating range of IC's power supply starts from 2.5V / 2.1V (BD8152FVM, BD8158FVM), it is possible to maintain the operation by composing the self-energizing type boost DC/DC converter application even if the input voltage is lower than 2.1V. This example is recommended for the application with battery input.

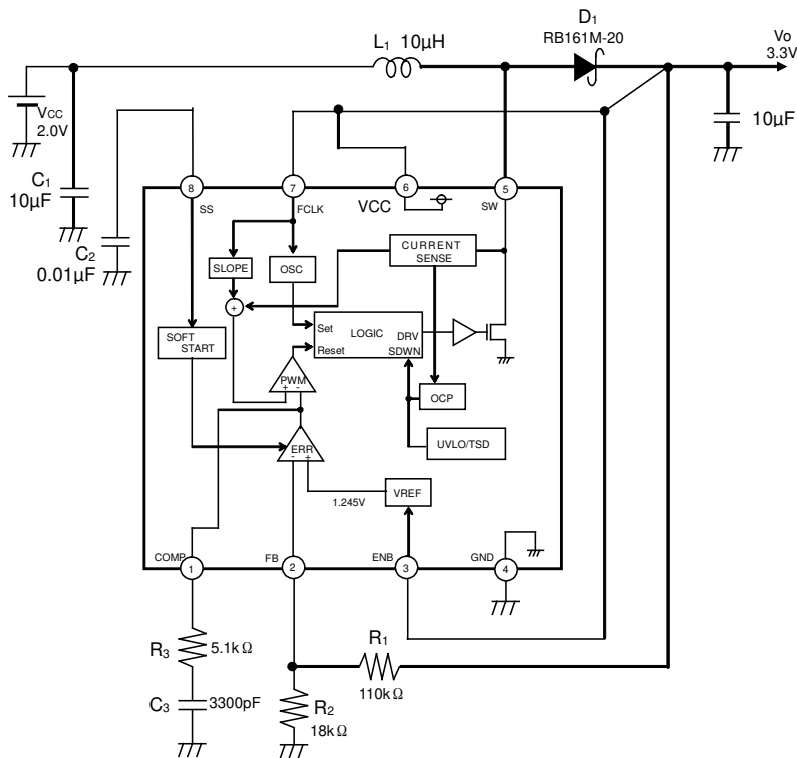

Figure 33. Self-Energizing Application Circuit Diagram Example

(4) SEPIC type application

When it is intended to compose the boost type DC/DC converter, the SEPIC type application is recommended. Since the switching voltage is generated by the value of input voltage + output voltage, pay utmost attention to the withstand voltage of SW pin.

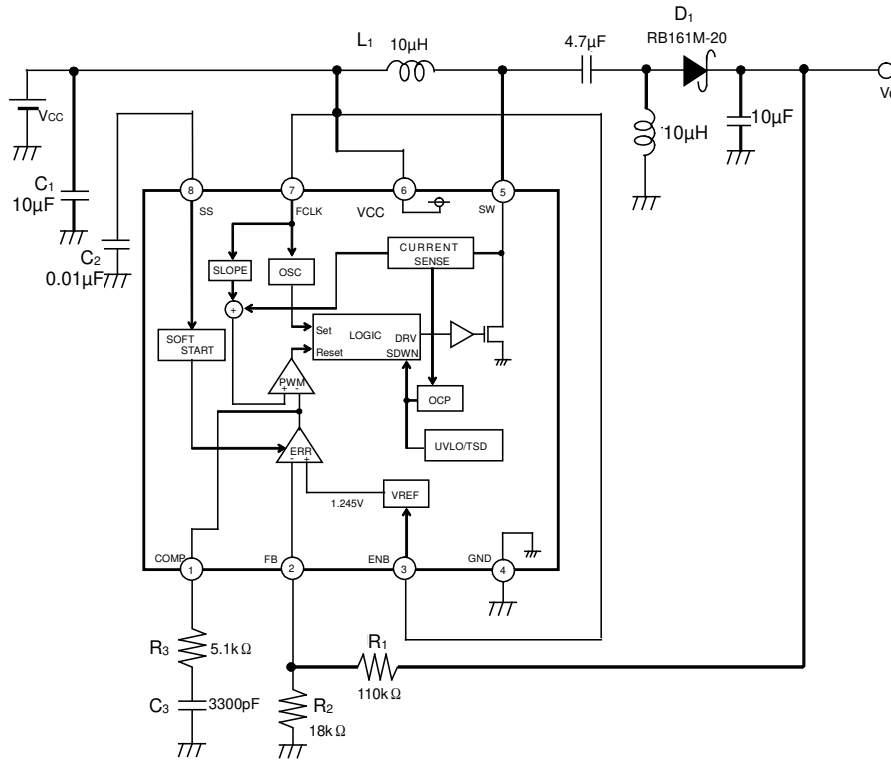

Figure 34. SEPIC Application Circuit Diagram Example

(5) When the Supply Voltage is over 4.0V (BD8158FVM only)

The Capacitor C4 is inserted to COMP pin, and it operates when the supply voltage is over 4.0V. In this case, switching frequency is limited to 600kHz.

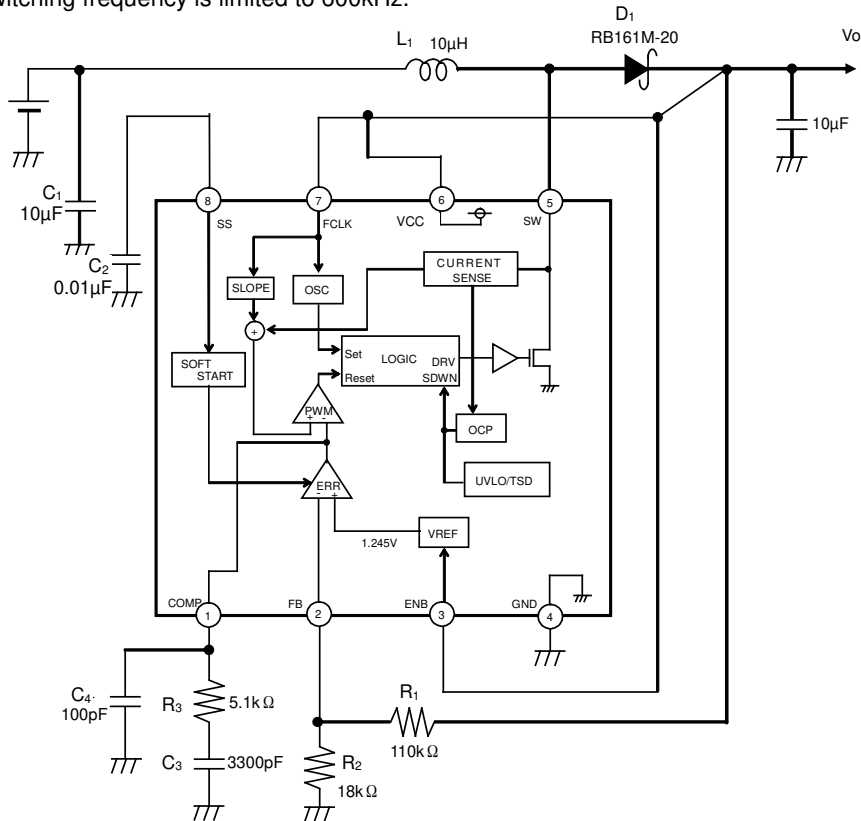

Figure 35. Circuit Diagram Example (Supply Voltage over 4.0 V)

I/O Equivalent Circuit

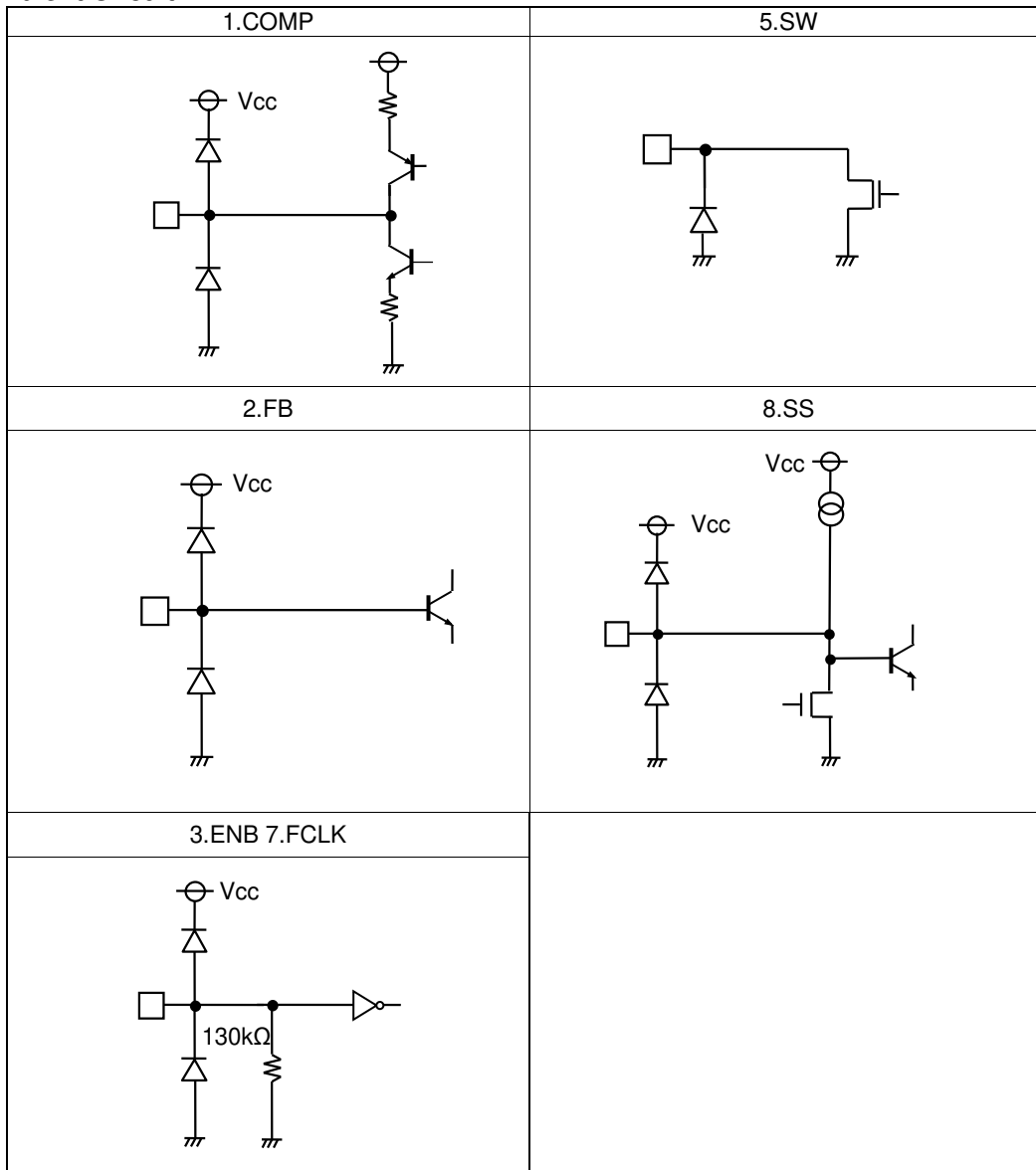
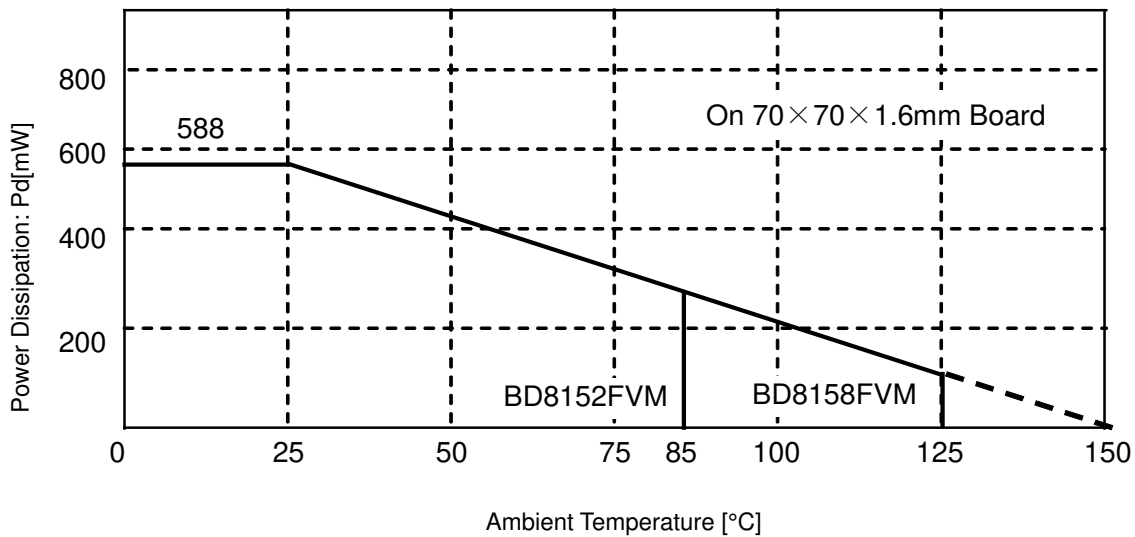

Figure 36. I/O Equivalent Circuit

Power Dissipation



Operational Notes

1. Reverse Connection of Power Supply

Connecting the power supply in reverse polarity can damage the IC. Take precautions against reverse polarity when connecting the power supply, such as mounting an external diode between the power supply and the IC's power supply pins.

2. Power Supply Lines

Design the PCB layout pattern to provide low impedance supply lines. Separate the ground and supply lines of the digital and analog blocks to prevent noise in the ground and supply lines of the digital block from affecting the analog block. Furthermore, connect a capacitor to ground at all power supply pins. Consider the effect of temperature and aging on the capacitance value when using electrolytic capacitors.

3. Ground Voltage

Ensure that no pins are at a voltage below that of the ground pin at any time, even during transient condition.

4. Ground Wiring Pattern

When using both small-signal and large-current ground traces, the two ground traces should be routed separately but connected to a single ground at the reference point of the application board to avoid fluctuations in the small-signal ground caused by large currents. Also ensure that the ground traces of external components do not cause variations on the ground voltage. The ground lines must be as short and thick as possible to reduce line impedance.

5. Thermal Consideration

Should by any chance the power dissipation rating be exceeded the rise in temperature of the chip may result in deterioration of the properties of the chip. The absolute maximum rating of the Pd stated in this specification is when the IC is mounted on a 70mm x 70mm x 1.6mm glass epoxy board. In case of exceeding this absolute maximum rating, increase the board size and copper area to prevent exceeding the Pd rating.

6. Recommended Operating Conditions

These conditions represent a range within which the expected characteristics of the IC can be approximately obtained. The electrical characteristics are guaranteed under the conditions of each parameter.

7. Inrush Current

When power is first supplied to the IC, it is possible that the internal logic may be unstable and inrush current may flow instantaneously due to the internal powering sequence and delays, especially if the IC has more than one power supply. Therefore, give special consideration to power coupling capacitance, power wiring, width of ground wiring, and routing of connections.

8. Operation Under Strong Electromagnetic Field

Operating the IC in the presence of a strong electromagnetic field may cause the IC to malfunction.

9. Testing on Application Boards

When testing the IC on an application board, connecting a capacitor directly to a low-impedance output pin may subject the IC to stress. Always discharge capacitors completely after each process or step. The IC's power supply should always be turned off completely before connecting or removing it from the test setup during the inspection process. To prevent damage from static discharge, ground the IC during assembly and use similar precautions during transport and storage.

10. Inter-pin Short and Mounting Errors

Ensure that the direction and position are correct when mounting the IC on the PCB. Incorrect mounting may result in damaging the IC. Avoid nearby pins being shorted to each other especially to ground, power supply and output pin. Inter-pin shorts could be due to many reasons such as metal particles, water droplets (in very humid environment) and unintentional solder bridge deposited in between pins during assembly to name a few.

Operational Notes – continued

11. Unused Input Pins

Input pins of an IC are often connected to the gate of a MOS transistor. The gate has extremely high impedance and extremely low capacitance. If left unconnected, the electric field from the outside can easily charge it. The small charge acquired in this way is enough to produce a significant effect on the conduction through the transistor and cause unexpected operation of the IC. So unless otherwise specified, unused input pins should be connected to the power supply or ground line.

12. Regarding the Input Pin of the IC

This monolithic IC contains P+ isolation and P substrate layers between adjacent elements in order to keep them isolated. P-N junctions are formed at the intersection of the P layers with the N layers of other elements, creating a parasitic diode or transistor. For example (refer to figure below):

- When $GND > Pin A$ and $GND > Pin B$, the P-N junction operates as a parasitic diode.
- When $GND > Pin B$, the P-N junction operates as a parasitic transistor.

Parasitic diodes inevitably occur in the structure of the IC. The operation of parasitic diodes can result in mutual interference among circuits, operational faults, or physical damage. Therefore, conditions that cause these diodes to operate, such as applying a voltage lower than the GND voltage to an input pin (and thus to the P substrate) should be avoided.

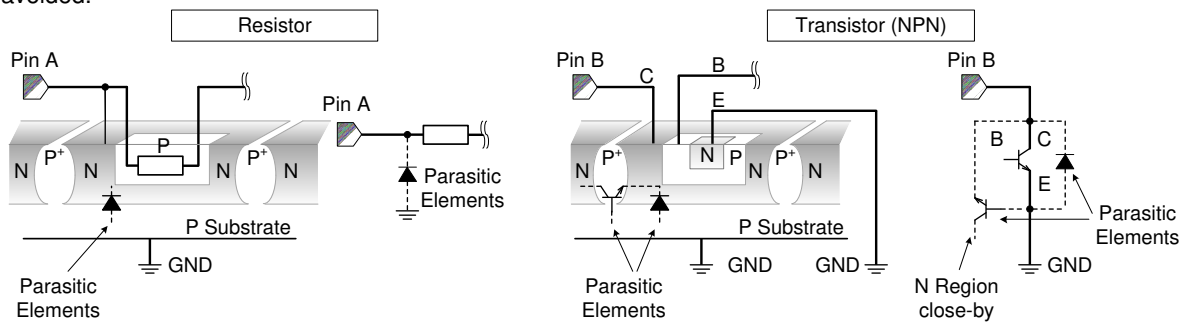

Figure 37. Example of monolithic IC structure

13. Thermal Shutdown Circuit(TSD)

This IC has a built-in thermal shutdown circuit that prevents heat damage to the IC. Normal operation should always be within the IC's power dissipation rating. If however the rating is exceeded for a continued period, the junction temperature (T_j) will rise which will activate the TSD circuit that will turn OFF all output pins. When the T_j falls below the TSD threshold, the circuits are automatically restored to normal operation.

Note that the TSD circuit operates in a situation that exceeds the absolute maximum ratings and therefore, under no circumstances, should the TSD circuit be used in a set design or for any purpose other than protecting the IC from heat damage.

14. Over Current Protection Circuit (OCP)

This IC incorporates an integrated overcurrent protection circuit that is activated when the load is shorted. This protection circuit is effective in preventing damage due to sudden and unexpected incidents. However, the IC should not be used in applications characterized by continuous operation or transitioning of the protection circuit.

Ordering Information

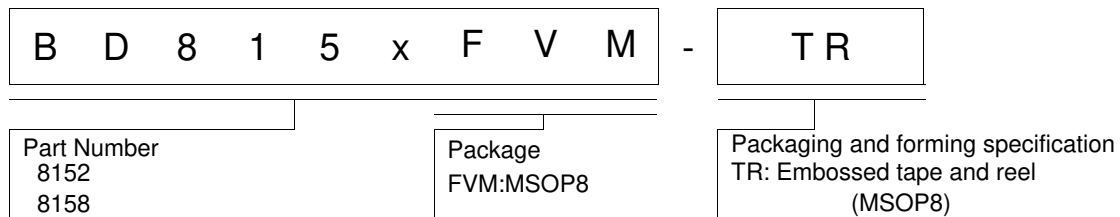

Marking Diagram

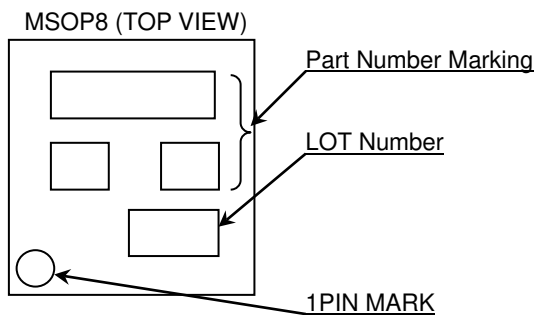

Part Number Marking	Package	Orderable Part Number
D8152	MSOP8	BD8152FVM - TR
D8158	MSOP8	BD8158FVM - TR

Physical Dimensions, Tape and Reel information

Package Name	MSOP8
--------------	-------

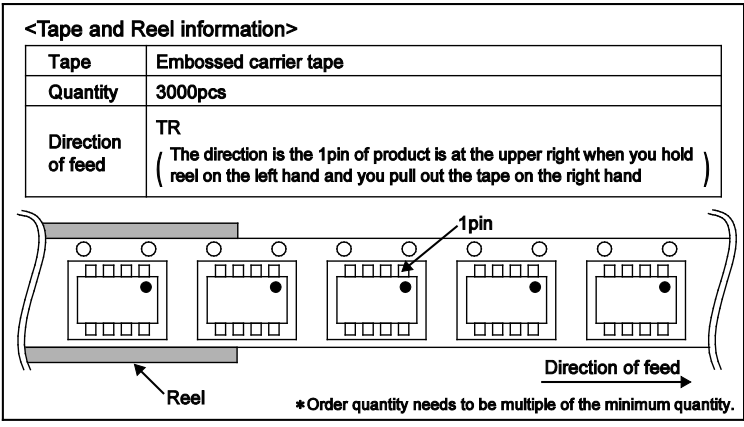
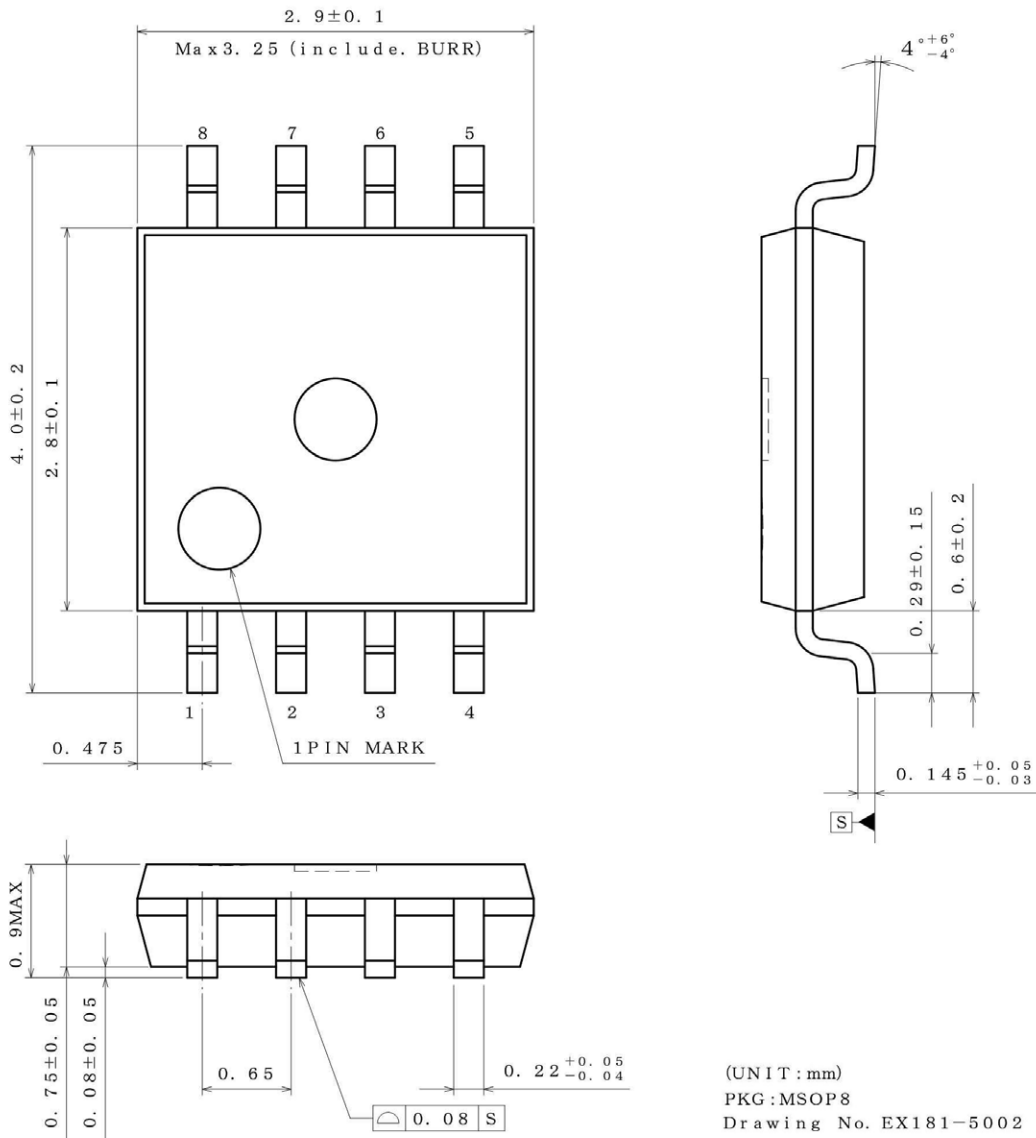

Revision History

Date	Revision	Changes
09.Sep.2014	001	New Release

Notice

Precaution on using ROHM Products

- Our Products are designed and manufactured for application in ordinary electronic equipments (such as AV equipment, OA equipment, telecommunication equipment, home electronic appliances, amusement equipment, etc.). If you intend to use our Products in devices requiring extremely high reliability (such as medical equipment ^(Note 1), transport equipment, traffic equipment, aircraft/spacecraft, nuclear power controllers, fuel controllers, car equipment including car accessories, safety devices, etc.) and whose malfunction or failure may cause loss of human life, bodily injury or serious damage to property ("Specific Applications"), please consult with the ROHM sales representative in advance. Unless otherwise agreed in writing by ROHM in advance, ROHM shall not be in any way responsible or liable for any damages, expenses or losses incurred by you or third parties arising from the use of any ROHM's Products for Specific Applications.

(Note1) Medical Equipment Classification of the Specific Applications

JAPAN	USA	EU	CHINA
CLASS III	CLASS III	CLASS II b	CLASS III
CLASS IV		CLASS III	

- ROHM designs and manufactures its Products subject to strict quality control system. However, semiconductor products can fail or malfunction at a certain rate. Please be sure to implement, at your own responsibilities, adequate safety measures including but not limited to fail-safe design against the physical injury, damage to any property, which a failure or malfunction of our Products may cause. The following are examples of safety measures:
 - Installation of protection circuits or other protective devices to improve system safety
 - Installation of redundant circuits to reduce the impact of single or multiple circuit failure
- Our Products are designed and manufactured for use under standard conditions and not under any special or extraordinary environments or conditions, as exemplified below. Accordingly, ROHM shall not be in any way responsible or liable for any damages, expenses or losses arising from the use of any ROHM's Products under any special or extraordinary environments or conditions. If you intend to use our Products under any special or extraordinary environments or conditions (as exemplified below), your independent verification and confirmation of product performance, reliability, etc. prior to use, must be necessary:
 - Use of our Products in any types of liquid, including water, oils, chemicals, and organic solvents
 - Use of our Products outdoors or in places where the Products are exposed to direct sunlight or dust
 - Use of our Products in places where the Products are exposed to sea wind or corrosive gases, including Cl₂, H₂S, NH₃, SO₂, and NO₂
 - Use of our Products in places where the Products are exposed to static electricity or electromagnetic waves
 - Use of our Products in proximity to heat-producing components, plastic cords, or other flammable items
 - Sealing or coating our Products with resin or other coating materials
 - Use of our Products without cleaning residue of flux (even if you use no-clean type fluxes, cleaning residue of flux is recommended); or Washing our Products by using water or water-soluble cleaning agents for cleaning residue after soldering
 - Use of the Products in places subject to dew condensation
- The Products are not subject to radiation-proof design.
- Please verify and confirm characteristics of the final or mounted products in using the Products.
- In particular, if a transient load (a large amount of load applied in a short period of time, such as pulse. is applied, confirmation of performance characteristics after on-board mounting is strongly recommended. Avoid applying power exceeding normal rated power; exceeding the power rating under steady-state loading condition may negatively affect product performance and reliability.
- De-rate Power Dissipation (Pd) depending on Ambient temperature (Ta). When used in sealed area, confirm the actual ambient temperature.
- Confirm that operation temperature is within the specified range described in the product specification.
- ROHM shall not be in any way responsible or liable for failure induced under deviant condition from what is defined in this document.

Precaution for Mounting / Circuit board design

- When a highly active halogenous (chlorine, bromine, etc.) flux is used, the residue of flux may negatively affect product performance and reliability.
- In principle, the reflow soldering method must be used; if flow soldering method is preferred, please consult with the ROHM representative in advance.

For details, please refer to ROHM Mounting specification

Precautions Regarding Application Examples and External Circuits

1. If change is made to the constant of an external circuit, please allow a sufficient margin considering variations of the characteristics of the Products and external components, including transient characteristics, as well as static characteristics.
2. You agree that application notes, reference designs, and associated data and information contained in this document are presented only as guidance for Products use. Therefore, in case you use such information, you are solely responsible for it and you must exercise your own independent verification and judgment in the use of such information contained in this document. ROHM shall not be in any way responsible or liable for any damages, expenses or losses incurred by you or third parties arising from the use of such information.

Precaution for Electrostatic

This Product is electrostatic sensitive product, which may be damaged due to electrostatic discharge. Please take proper caution in your manufacturing process and storage so that voltage exceeding the Products maximum rating will not be applied to Products. Please take special care under dry condition (e.g. Grounding of human body / equipment / solder iron, isolation from charged objects, setting of Ionizer, friction prevention and temperature / humidity control).

Precaution for Storage / Transportation

1. Product performance and soldered connections may deteriorate if the Products are stored in the places where:
 - [a] the Products are exposed to sea winds or corrosive gases, including Cl₂, H₂S, NH₃, SO₂, and NO₂
 - [b] the temperature or humidity exceeds those recommended by ROHM
 - [c] the Products are exposed to direct sunshine or condensation
 - [d] the Products are exposed to high Electrostatic
2. Even under ROHM recommended storage condition, solderability of products out of recommended storage time period may be degraded. It is strongly recommended to confirm solderability before using Products of which storage time is exceeding the recommended storage time period.
3. Store / transport cartons in the correct direction, which is indicated on a carton with a symbol. Otherwise bent leads may occur due to excessive stress applied when dropping of a carton.
4. Use Products within the specified time after opening a humidity barrier bag. Baking is required before using Products of which storage time is exceeding the recommended storage time period.

Precaution for Product Label

QR code printed on ROHM Products label is for ROHM's internal use only.

Precaution for Disposition

When disposing Products please dispose them properly using an authorized industry waste company.

Precaution for Foreign Exchange and Foreign Trade act

Since our Products might fall under controlled goods prescribed by the applicable foreign exchange and foreign trade act, please consult with ROHM representative in case of export.

Precaution Regarding Intellectual Property Rights

1. All information and data including but not limited to application example contained in this document is for reference only. ROHM does not warrant that foregoing information or data will not infringe any intellectual property rights or any other rights of any third party regarding such information or data. ROHM shall not be in any way responsible or liable for infringement of any intellectual property rights or other damages arising from use of such information or data.:
2. No license, expressly or implied, is granted hereby under any intellectual property rights or other rights of ROHM or any third parties with respect to the information contained in this document.

Other Precaution

1. This document may not be reprinted or reproduced, in whole or in part, without prior written consent of ROHM.
2. The Products may not be disassembled, converted, modified, reproduced or otherwise changed without prior written consent of ROHM.
3. In no event shall you use in any way whatsoever the Products and the related technical information contained in the Products or this document for any military purposes, including but not limited to, the development of mass-destruction weapons.
4. The proper names of companies or products described in this document are trademarks or registered trademarks of ROHM, its affiliated companies or third parties.

General Precaution

1. Before you use our Products, you are requested to carefully read this document and fully understand its contents. ROHM shall not be in any way responsible or liable for failure, malfunction or accident arising from the use of any ROHM's Products against warning, caution or note contained in this document.
2. All information contained in this document is current as of the issuing date and subject to change without any prior notice. Before purchasing or using ROHM's Products, please confirm the latest information with a ROHM sales representative.
3. The information contained in this document is provided on an "as is" basis and ROHM does not warrant that all information contained in this document is accurate and/or error-free. ROHM shall not be in any way responsible or liable for any damages, expenses or losses incurred by you or third parties resulting from inaccuracy or errors of or concerning such information.