

# Inverted Thru Board Card Edge: 00-9159-BTB

## General Description



KYOCERA AVX has developed the 1-Piece bottom entry card edge connector to allow a perpendicular PCB to be mated to a top mounted main FR4 or metal core PCB from the bottom side. The most popular application on the market is in the LED bulb market where the FR4 driver card needs to mate to the top pads on a metal core LED board. A unique design feature of the KYOCERA AVX connector is that it allows for both a 1.6mm and 0.8mm mating PCB thickness, giving designers flexibility in their PCB layout and selection. The additional “Anti-Touch” cap can be ordered pre-assembled onto the connector or separately. This component protects an individual for electrical contact if the lens comes off or the bulb is broken. This is a UL mandated safety requirement.

The connectors offer a range of 2 positions to 6 positions in order to add additional functionality in the application design such as color control or specific control lines. The connector is UL rated with halogen free material and capable of operating temperatures up to 120°C.

### APPLICATIONS

- Provides perpendicular, bottom entry PCB mating to a top mounted card edge contact based connector
- Reference application notes 201-01-137
- Reference Product Specification 201-01-132UL

### FEATURES AND BENEFITS

- Available 2p-6p for added design functionality and color control in bulb applications
- Low profile top mounted design does not interfere with LED's
- Gold plated BeCu contact system for high reliability in harsh environments
- Accepts both 0.8mm and 1.6mm PCB's for added design options

### ELECTRICAL

- Current Rating: 2 Amps / Contact
- Voltage Rating: 300 VAC

### ENVIRONMENTAL

- Operating Temperature: -40°C to +125°C

### MECHANICAL

- Insulator Material: Halogen Free Nylon UL94VO
- Contact Material: Beryllium Copper
- Plating: Gold / Tin over Nickel
- Durability 10 Cycles

### HOW TO ORDER

**00**  
Prefix

**9159**  
Series

**00X**  
Number of Ways

Code	No of Ways	Details
002	2	Page 83
003	3	Page 84
004	4	Page 85
005	5	Page 86
006	6	Page 87

**50X**  
Single Part PCB Strip Connector

501 = Through The Board, Edge Card, No Cap  
502 = Through The Board, Edge Card, Cap Fitted 1.6±0.10

**9**  
Insulator Color

Code	Color	Application
9	White	UL Approved Standard

**06**  
Packaging Options

06 = Gold Plating on Nos with Tin on Tails



Certification: UL File #E90723

# Inverted Thru Board Card Edge: 00-9159-BTB

## 2 Position



### 2 WAY THROUGH THE BOARD MATING EDGE CARD CONNECTOR

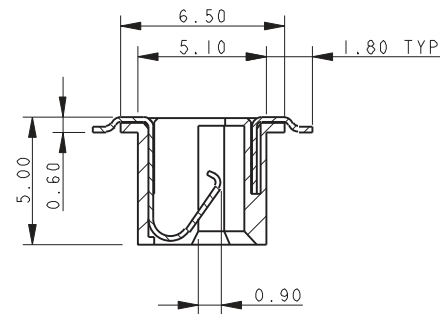
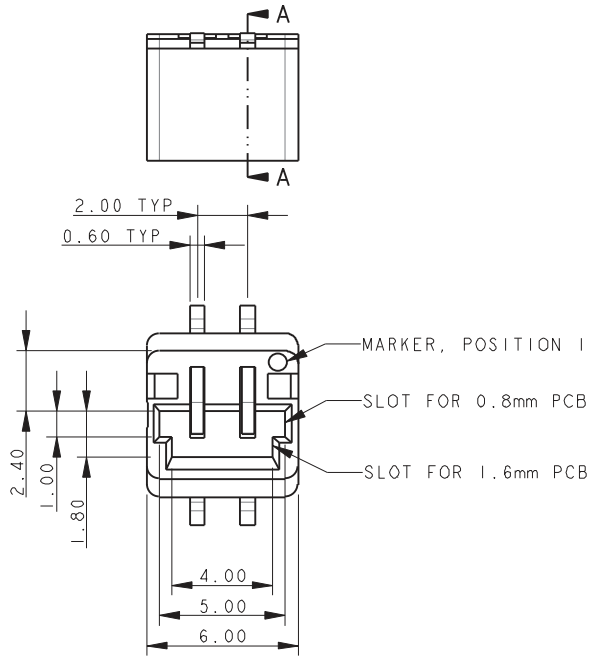

SECTION A-A

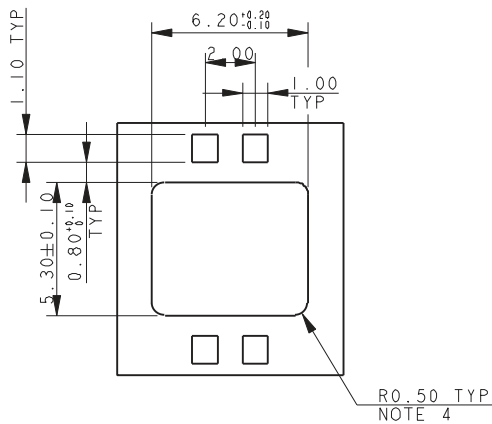
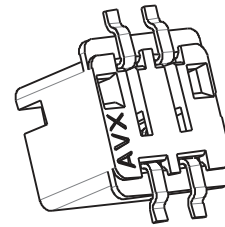

MOUNTING PCB  
(TOP SIDE)

### PACKING DETAILS

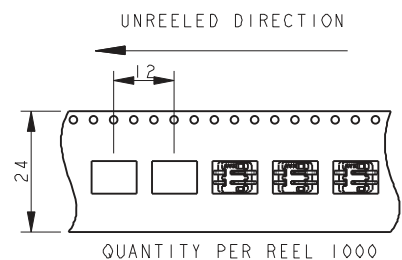
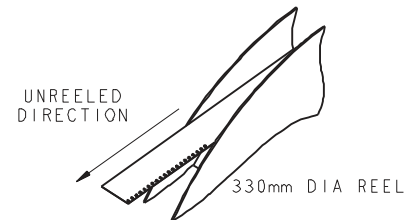

NOTES:

1. THROUGH THE BOARD 2 WAY EDGE CARD CONNECTOR. FOR FURTHER DETAILS REFER TO PRODUCT SPECIFICATION 201-01-136.
2. FOR MATING PCB EITHER 0.8MM OR 1.6MM THICK. REFER TO PAGE 88 FOR MATING PCB DETAILS.
3. CONNECTOR TOP MOUNTING ON PCB.
4. UP TO 0.5MM RAD TO MATCH CONNECTOR PROFILE.
5. ALL DIMENSIONS  $\pm 0.20$  UNLESS TOLERANCE SPECIFIED.
6. INSULATOR: PAR4T, GLASS FILLED, HALOGEN FREE, UL94 V-0, COLOR SEE PAGE 82.
7. CONTACT: COPPER ALLOW, NICKEL PLATED WITH GOLD FLASH ON NOSE AND TIN ON TAILS.
8. BRACKET: COPPER ALLOY, PLATING TIN OVER NICKEL.
9. PACKING IN TAPE AND REEL, 1000 PIECES PER REEL.
10. CONTACT TAILS COPLANARITY WITHIN 0.10.
11. REFER TO PAGE 91 FOR MATCHING PROTECTING CAP.
12. UL REFERENCE E90723.

# Inverted Thru Board Card Edge: 00-9159-BTB

## 3 Position

### 3 WAY THROUGH THE BOARD MATING EDGE CARD CONNECTOR

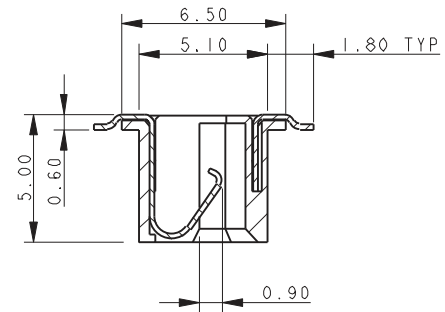
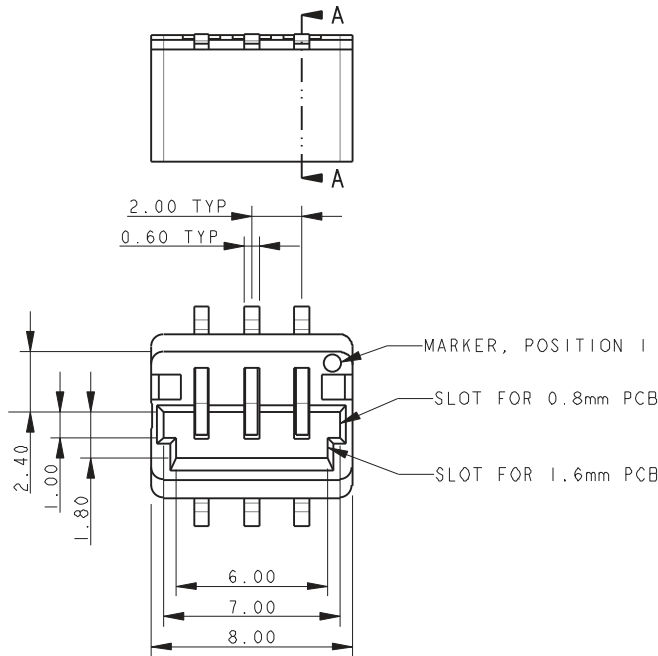

SECTION A-A

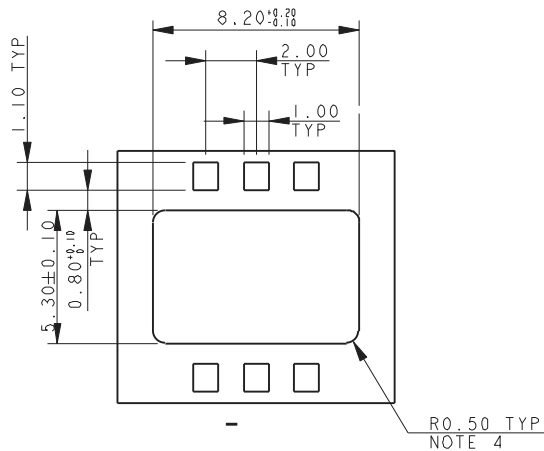
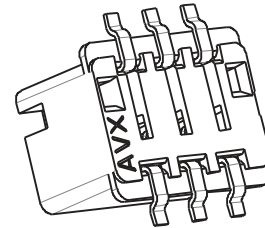

MOUNTING PCB  
(TOP SIDE)

### PACKING DETAILS

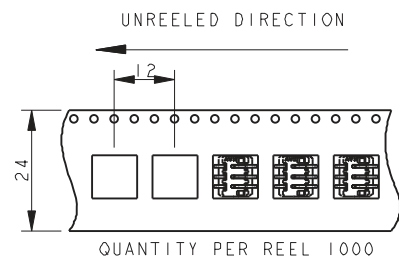
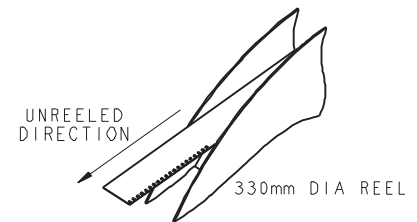

#### NOTES:

1. THROUGH THE BOARD 3 WAY EDGE CARD CONNECTOR. FOR FURTHER DETAILS REFER TO PRODUCT SPECIFICATION 201-01-136.
2. FOR MATING PCB EITHER 0.8MM OR 1.6MM THICK. REFER TO PAGE 88 FOR MATING PCB DETAILS.
3. CONNECTOR TOP MOUNTING ON PCB.
4. UP TO 0.5MM RAD TO MATCH CONNECTOR PROFILE.
5. ALL DIMENSIONS ±0.20 UNLESS TOLERANCE SPECIFIED.
6. INSULATOR: PAR4T, GLASS FILLED, HALOGEN FREE, UL94 V-0, COLOR SEE PAGE 82.
7. CONTACT: COPPER ALLOW, NICKEL PLATED WITH GOLD FLASH ON NOSE AND TIN ON TAILS.
8. BRACKET: COPPER ALLOY, PLATING TIN OVER NICKEL.
9. PACKING IN TAPE AND REEL, 1000 PIECES PER REEL.
10. CONTACT TAILS COPLINARITY WITHIN 0.10.
11. REFER TO PAGE 91 FOR MATCHING PROTECTING CAP.
12. UL REFERENCE E90723.

# Inverted Thru Board Card Edge: 00-9159-BTB

## 4 Position

### 4 WAY THROUGH THE BOARD MATING EDGE CARD CONNECTOR

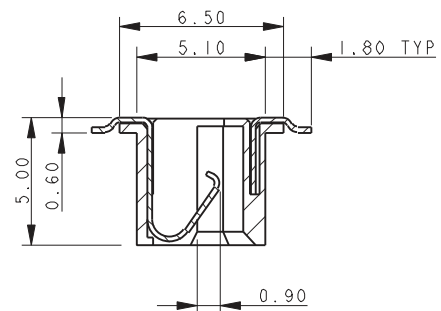
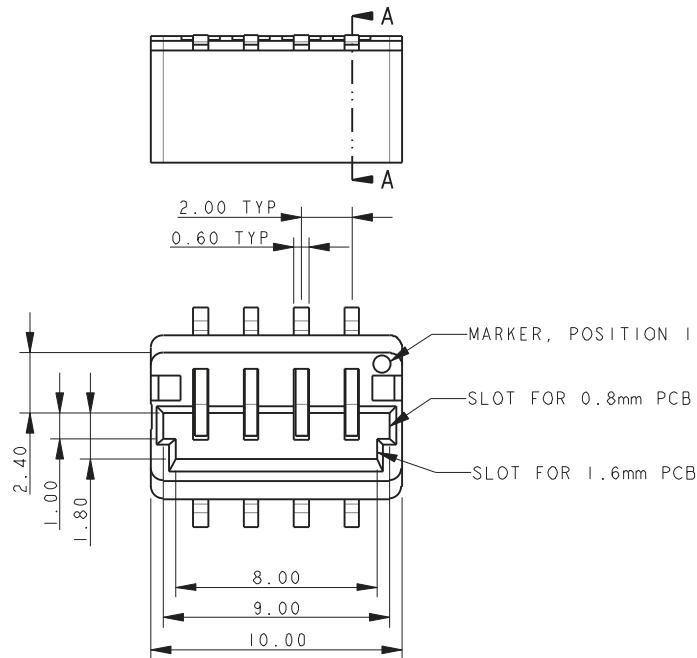

SECTION A-A

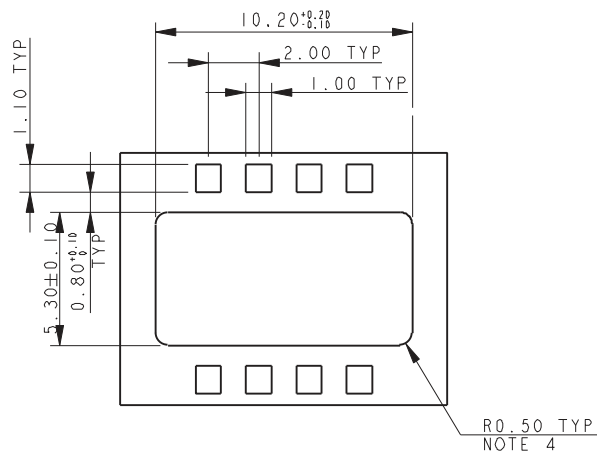
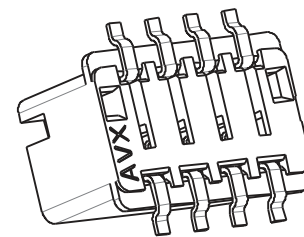

MOUNTING PCB  
(TOP SIDE)

### PACKING DETAILS

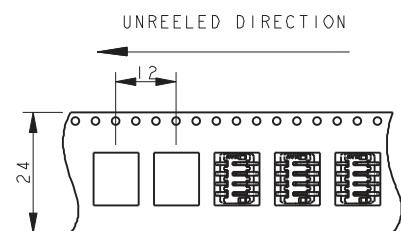
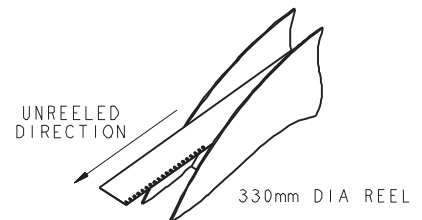

QUANTITY PER REEL 1000

NOTES:

1. THROUGH THE BOARD 4 WAY EDGE CARD CONNECTOR. FOR FURTHER DETAILS REFER TO PRODUCT SPECIFICATION 201-01-136.
2. FOR MATING PCB EITHER 0.8MM OR 1.6MM THICK. REFER TO PAGE 88 FOR MATING PCB DETAILS.
3. CONNECTOR TOP MOUNTING ON PCB.
4. UP TO 0.5MM RAD TO MATCH CONNECTOR PROFILE.
5. ALL DIMENSIONS  $\pm 0.20$  UNLESS TOLERANCE SPECIFIED.
6. INSULATOR: PAR4T, GLASS FILLED, HALOGEN FREE, UL94 V-0, COLOR SEE PAGE 82.
7. CONTACT: COPPER ALLOW, NICKEL PLATED WITH GOLD FLASH ON NOSE AND TIN ON TAILS.
8. BRACKET: COPPER ALLOY, PLATING TIN OVER NICKEL.
9. PACKING IN TAPE AND REEL, 1000 PIECES PER REEL.
10. CONTACT TAILS COPLANARITY WITHIN 0.10.
11. REFER TO PAGE 91 FOR MATCHING PROTECTING CAP.
12. UL REFERENCE E90723.

# Inverted Thru Board Card Edge: 00-9159-BTB

## 5 Position

### 5 WAY THROUGH THE BOARD MATING EDGE CARD CONNECTOR

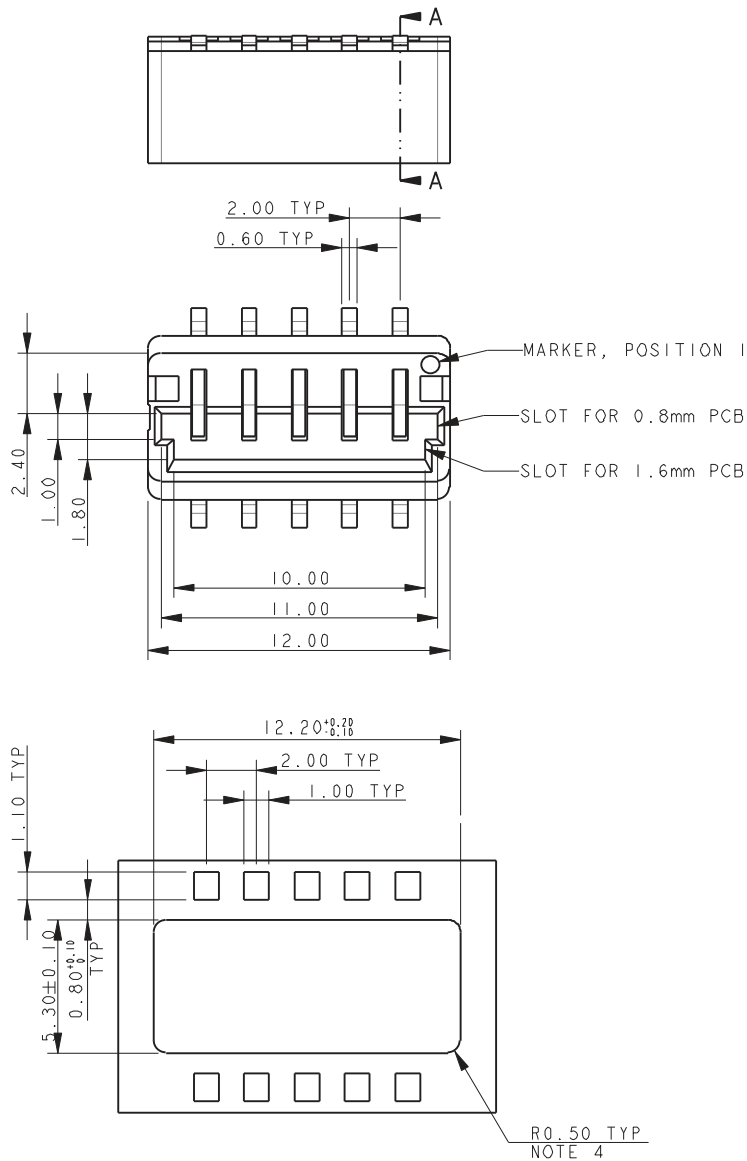

**MOUNTING PCB  
(TOP SIDE)**

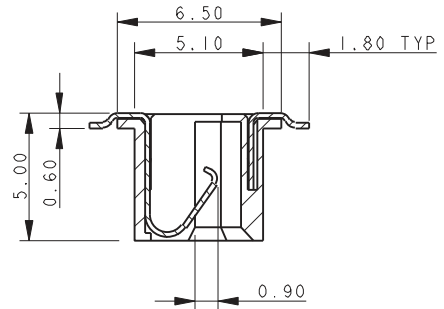

**SECTION A-A**

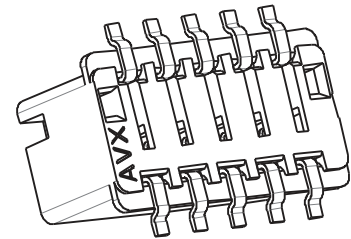

### PACKING DETAILS

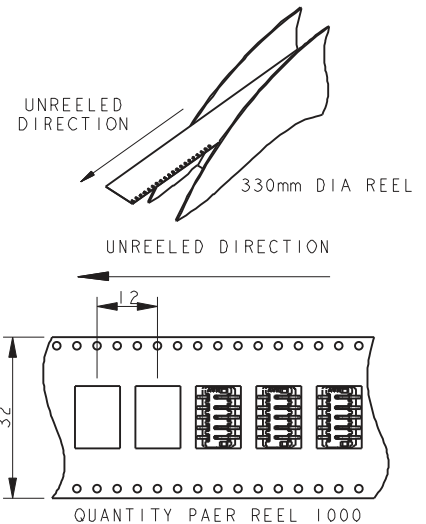

#### NOTES:

1. THROUGH THE BOARD 5 WAY EDGE CARD CONNECTOR. FOR FURTHER DETAILS REFER TO PRODUCT SPECIFICATION 201-01-136.
2. FOR MATING PCB EITHER 0.8MM OR 1.6MM THICK. REFER TO PAGE 88 FOR MATING PCB DETAILS.
3. CONNECTOR TOP MOUNTING ON PCB.
4. UP TO 0.5MM RAD TO MATCH CONNECTOR PROFILE.
5. ALL DIMENSIONS ±0.20 UNLESS TOLERANCE SPECIFIED.
6. INSULATOR: PAR4T, GLASS FILLED, HALOGEN FREE, UL94 V-0, COLOR SEE PAGE 82.
7. CONTACT: COPPER ALLOW, NICKEL PLATED WITH GOLD FLASH ON NOSE AND TIN ON TAILS.
8. BRACKET: COPPER ALLOY, PLATING TIN OVER NICKEL.
9. PACKING IN TAPE AND REEL, 1000 PIECES PER REEL.
10. CONTACT TAILS COPLINARITY WITHIN 0.10.
11. REFER TO PAGE 91 FOR MATCHING PROTECTING CAP.
12. UL REFERENCE E90723.

# Inverted Thru Board Card Edge: 00-9159-BTB

## 6 Position

### 6 WAY THROUGH THE BOARD MATING EDGE CARD CONNECTOR

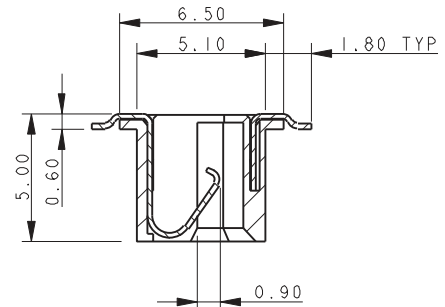
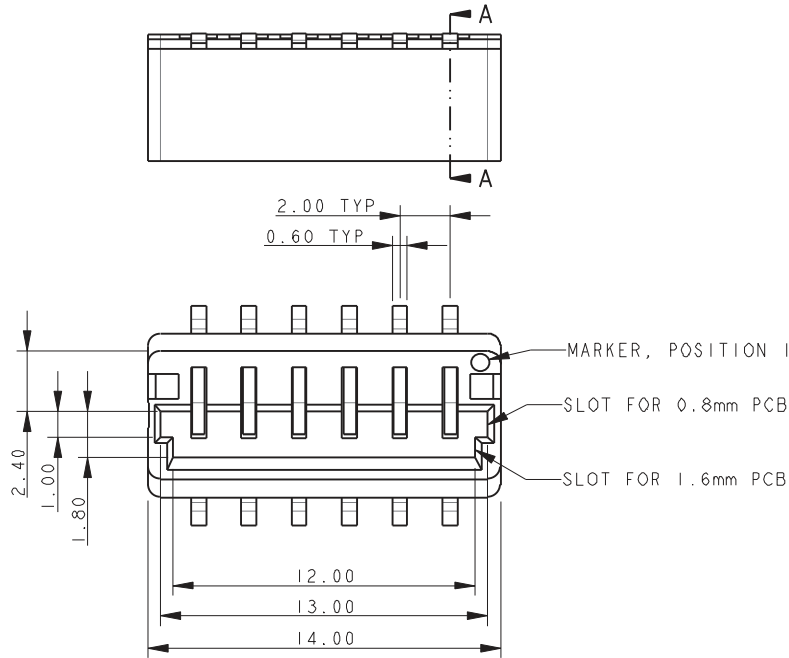

### SECTION A-A

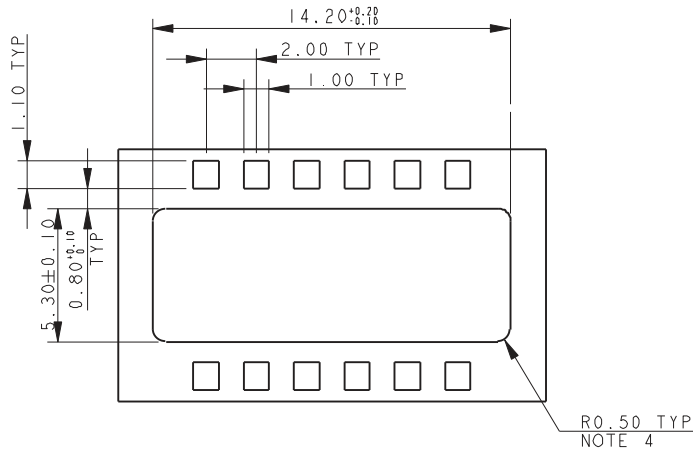
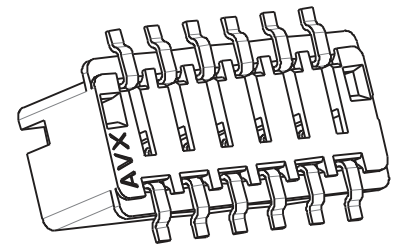

### MOUNTING PCB (TOP SIDE)

### PACKING DETAILS

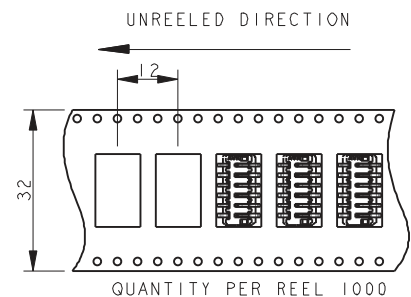
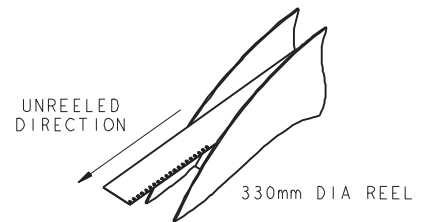

#### NOTES:

1. THROUGH THE BOARD 6 WAY EDGE CARD CONNECTOR. FOR FURTHER DETAILS REFER TO PRODUCT SPECIFICATION 201-01-136.
2. FOR MATING PCB EITHER 0.8MM OR 1.6MM THICK. REFER TO PAGE 88 FOR MATING PCB DETAILS.
3. CONNECTOR TOP MOUNTING ON PCB.
4. UP TO 0.5MM RAD TO MATCH CONNECTOR PROFILE.
5. ALL DIMENSIONS ±0.20 UNLESS TOLERANCE SPECIFIED.
6. INSULATOR: PAR4T, GLASS FILLED, HALOGEN FREE, UL94 V-0, COLOR SEE PAGE 82.
7. CONTACT: COPPER ALLOW, NICKEL PLATED WITH GOLD FLASH ON NOSE AND TIN ON TAILS.
8. BRACKET: COPPER ALLOY, PLATING TIN OVER NICKEL.
9. PACKING IN TAPE AND REEL, 1000 PIECES PER REEL.
10. CONTACT TAILS COPLINARITY WITHIN 0.10.
11. REFER TO PAGE 91 FOR MATCHING PROTECTING CAP.
12. UL REFERENCE E90723.

# Inverted Thru Board Card Edge: 00-9159-BTB

## Thru Board Mating Edge Card Connector – With Cap

### THROUGH THE BOARD MATING EDGE CARD CONNECTOR – WITH CAP 00-9159-00X-502-X06

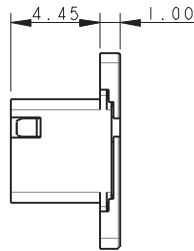
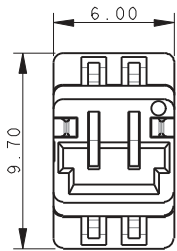

00-9159-002-502-906

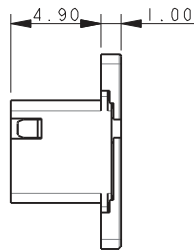
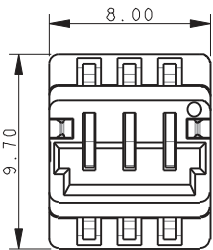

00-9159-003-502-906

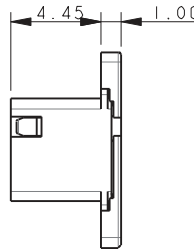
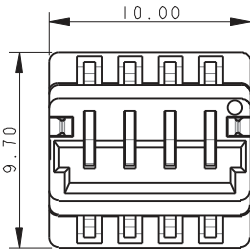

00-9159-004-502-906

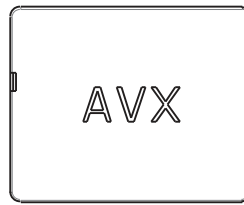
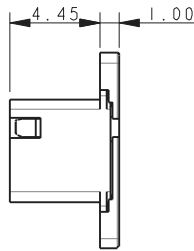
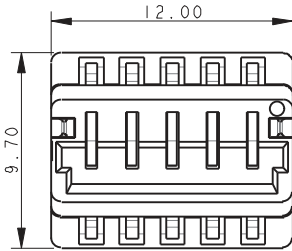

00-9159-005-502-906

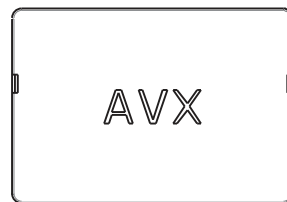
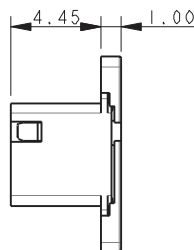
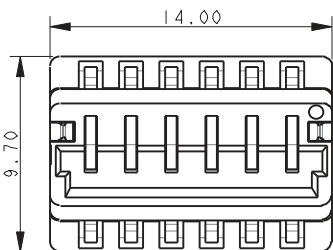

00-9159-006-502-906

**NOTES:**

- 00-9159-00X-501-X06 WITH CAP SUPPLIED FITTED.
- DRAWINGS SHOW OUTLINE DIMENSIONS OF THE 00-9159-00X-502-X06 ASSEMBLIES. ALL OTHER DETAILS ARE AS 00-9159-00X-501-X06 ON PAGES 83-87.
- GENERAL TOLERANCE  $\pm 0.20$ .
- PACKING ORIENTATION.
- UL REFERENCE E90723.

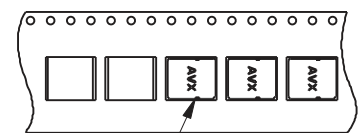

NOTE 4

# Inverted Thru Board Card Edge: 00-9159-BTB

## Thru Board Mating Edge Card Connector – Mating PCB



### THROUGH THE BOARD MATING EDGE CARD CONNECTOR – MATING PCB

#### MATING PCB – 0.8MM PCB

#### MATING PCB – 1.6MM PCB

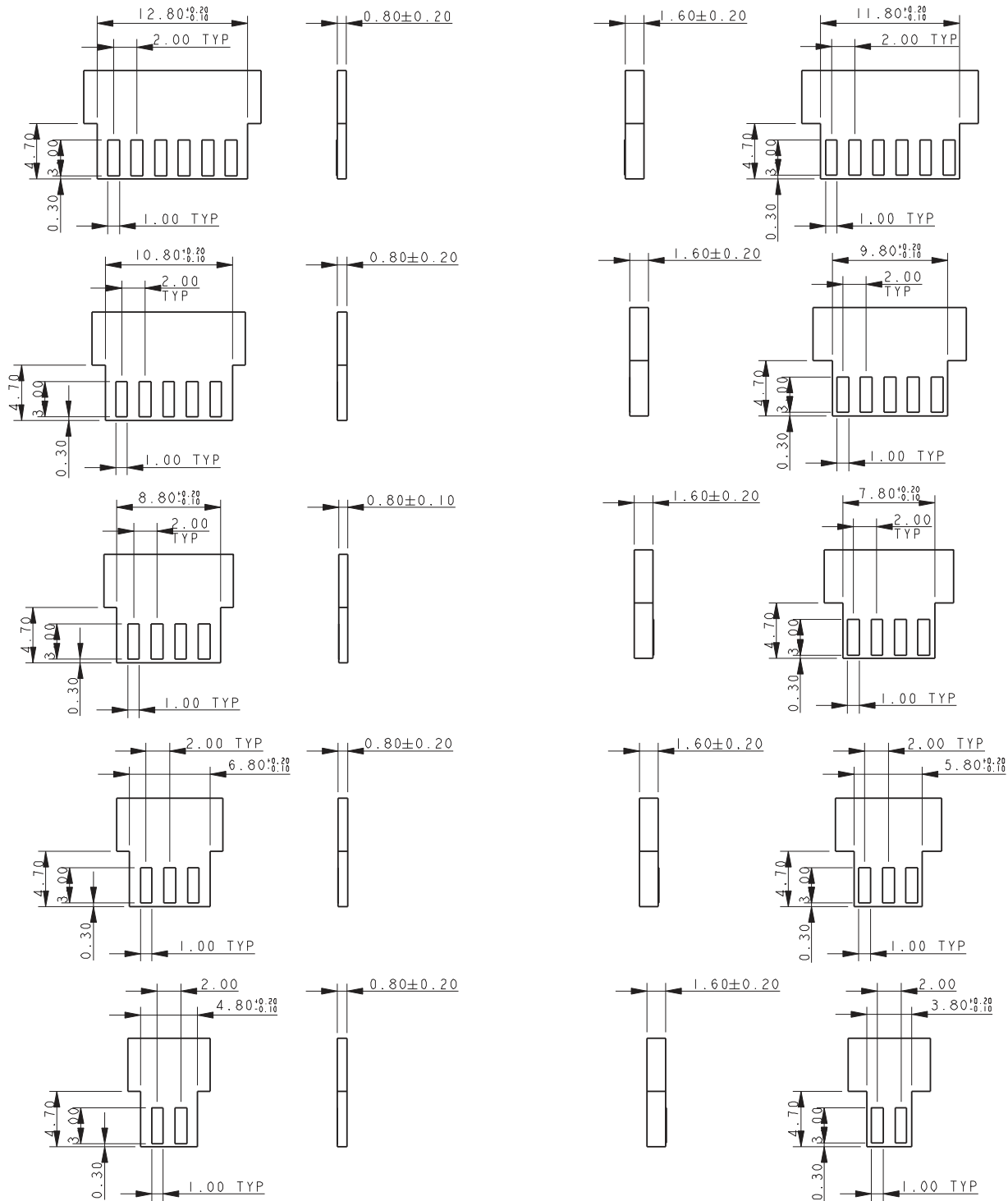

#### NOTES:

1. CORRECT DIMENSIONS FOR EITHER 0.80MM OR F1.60MM PCB THICKENSS MUST BE USED.
2. THICKNESS OF PCB INCLUDES ALL LAYERS INCLUDING COPPER AND PLATING.
3. PADS TO BE PLATED GOLD OVER NICKEL UNDERCOAT.
4. GENERAL TOLERANCE ±0.10 UNLESS STATED.



### THROUGH THE BOARD MATING EDGE CARD CONNECTOR

#### CONNECTOR/PCB ASSEMBLY 0.8MM MATING PCB NO CAP

#### CONNECTOR/PCB ASSEMBLY 1.6MM MATING PCB WITH CAP

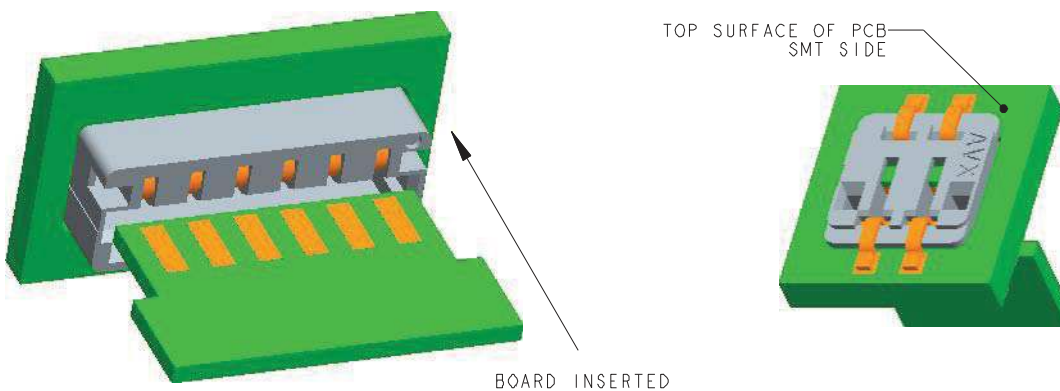
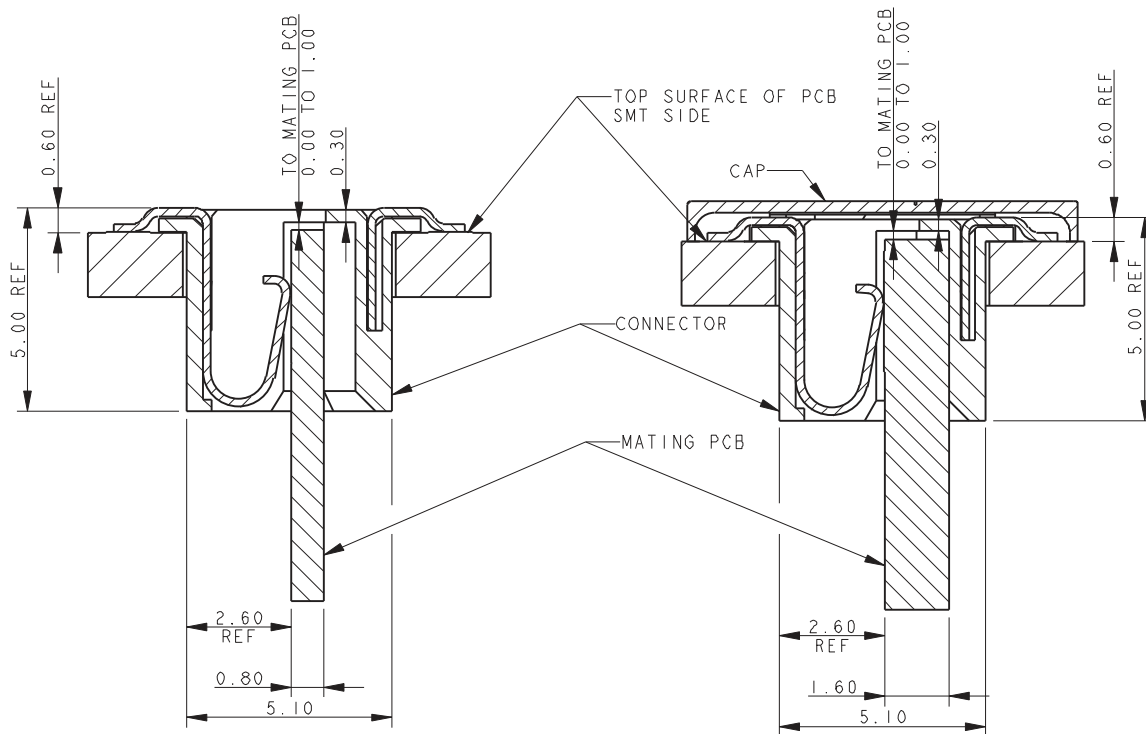

#### NOTES:

1. THROUGH THE BOARD EDGE CARD CONNECTOR.
2. FOR MATING PCB EITHER 0.8MM OR 1.6MM THICK. REFER TO PAGE 88 FOR MATING PCB DETAILS.
3. CONNECTOR TOP MOUNTING ON PCB.
4. PAD DETAILS ON THE MATING PCB ALLOW CONTACT TO BE MADE IN ANY POSITION FROM THE STOP FACE UP TO 1MM FROM THE STOP FACE.
5. GENERAL TOLERANCE  $\pm 0.20$  UNLESS STATED.

# Inverted Thru Board Card Edge: 00-9159-BTB

## Accessory – Protection Cap

### ACCESSORY – PROTECTING CAP

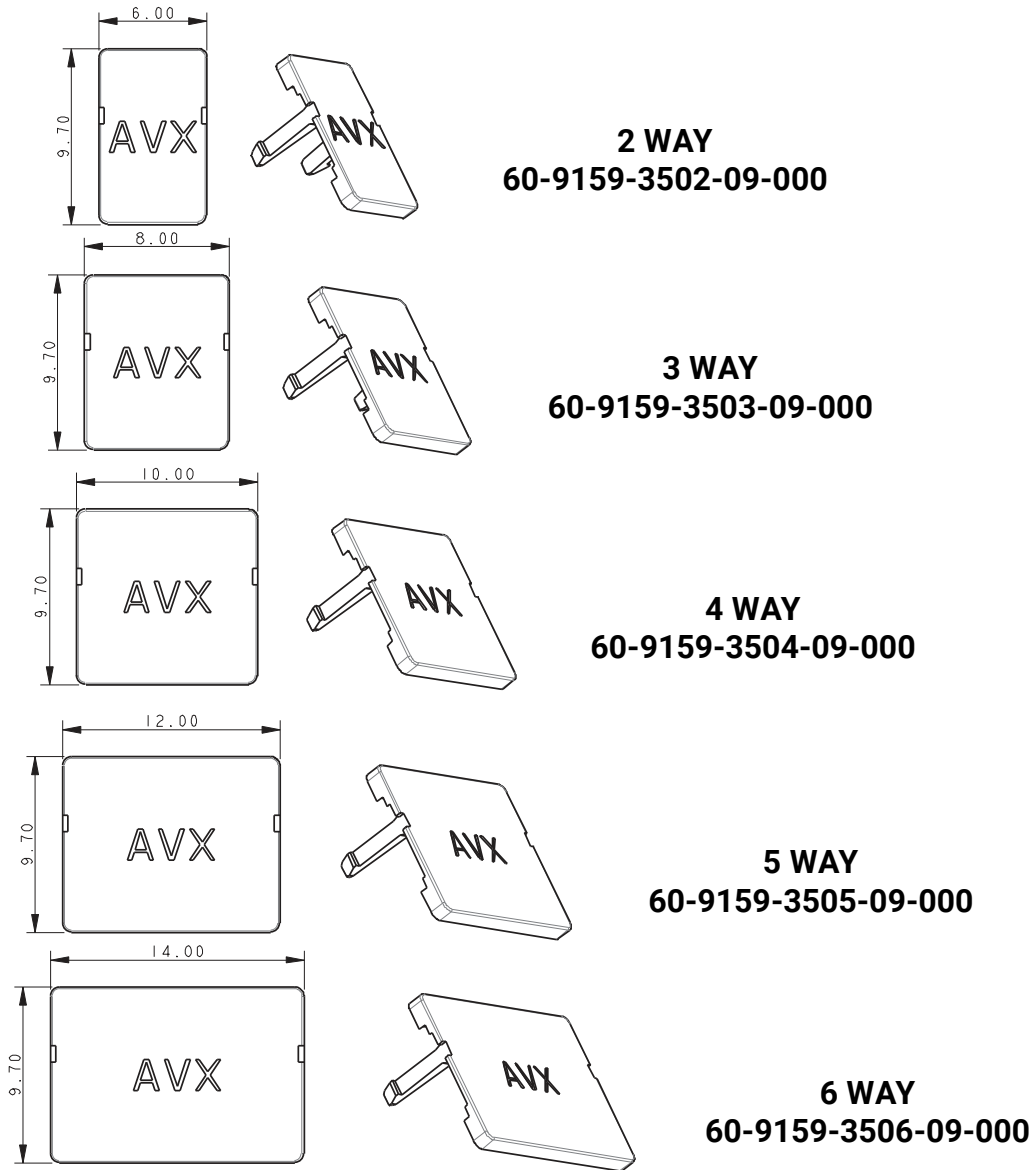

**NOTES:**

1. PROTECTING CAP, ACCESSORY, NOT SUPPLIED WITH CONNECTOR.
2. CLIPS TO TOP OF CONNECTOR TO COVE ALL METAL COMPONENTS.
3. MATERIAL: PA4T, GLASS FILLED, HALOGEN FREE, UL94 V-0. COLOR CODE REFER TO PAGE 82, "X" IN PART NUMBER.
4. SUPPLIED IN BAGS OF 100 PIECES.
5. GENERAL TOLERANCE  $\pm 0.20$ .
6. UL REFERENCE E90723.

### ASSEMBLED CAP

