

TECHNICAL CHARACTERISTICS

MATERIAL  
 CONTACT MATERIAL: PHOSPHOR BRONZE  
 CONTACT TYPE: STAMPED  
 CONTACT PLATING: TIN  
 QUALITY CLASS: 25 MATING CYCLES  
 PITCH: FOR 1.00 MM

ENVIRONMENTAL  
 OPERATING TEMPERATURE: -25 UP TO 85°C  
 COMPLIANCE: LEAD FREE AND ROHS

ELECTRICAL  
 CURRENT RATING: 1A  
 WORKING VOLTAGE: 50V AC  
 CONTACT RESISTANCE: 20 mΩ MAX

WIRE DIMENSION:  
 AWG: AWG 32 - 28

PACKAGING  
 1 KPCS REEL

RoHS Compliant			
B	08-AUG-17	TPK	AK
A	29-JUL-14	PDF	AS
REV	DATE	FILE	BY

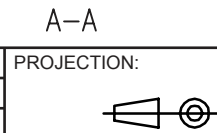

APPROVAL: BBu

GENERAL TOLERANCE  
 .X = +/- 0.2  
 .XX = +/- 0.15

UNIT: MM  
 SCALE:  
 SHEET: 1/3



DESCRIPTION: WR-WTB 1.00 MM FEMALE CRIMP TERMINAL  
 WERI PART NO: 665 101 137 22

SIZE  
**A4**

1

2

3

4

5

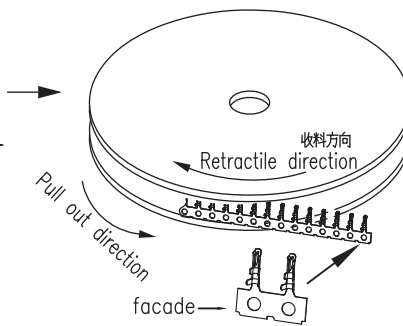
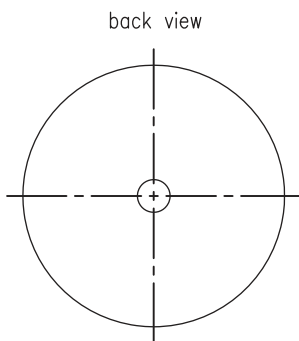
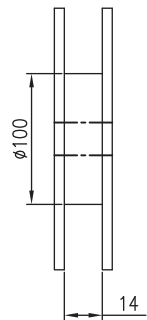
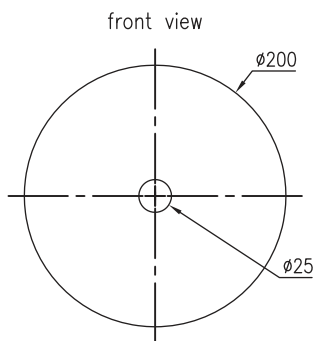

packing Quantity:1000pcs/Reel

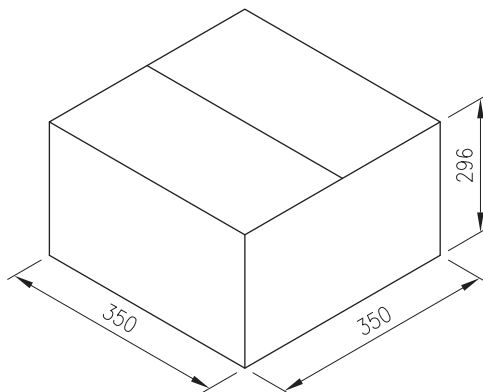
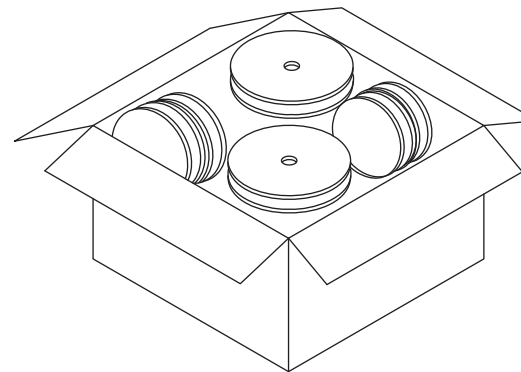
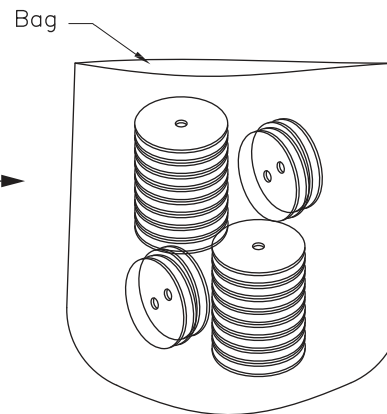

Q'ty/Reel	Reel/Carton	Q'ty/Carton
1 Kpcs	20Reel	20 Kpcs

RoHS Compliant

PROJECTION:



GENERAL TOLERANCE

.X = +/- 0.2

.XX = +/- 0.15



APPROVAL: BBu

UNIT: MM

SCALE:

SHEET: 2/3

DRAW: AS

DESCRIPTION: WR-WTB 1.00 MM FEMALE CRIMP TERMINAL

WERI PART NO: 665 101 137 22

SIZE

**A4**

REV	DATE	FILE	BY

1

2

3

4

5

## Cautions and Warnings:

This electronic component is designed and developed with the intention for use in general electronics equipments.



Before incorporating the components into any equipments in the field such as aerospace, aviation, nuclear control, submarine, transportation, (automotive control, train control, ship control), transportation signal, disaster prevention, medical, public information network etc. where higher safety and reliability are especially required or if there is possibility of direct damage or injury to human body, Würth Elektronik must be asked for a written approval.

In addition, even electronic component in general electronic equipments, when used in electrical circuits that require high safety, reliability functions or performance, the sufficient reliability evaluation-check for the safety must be performed before by the user before usage.

A

B

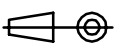
C

RoHS Compliant				PROJECTION: 	GENERAL TOLERANCE .X = +/- 0.2 .XX = +/- 0.15		DESCRIPTION: DISCLAIMER	SIZE <b>A4</b>
G								
F								
E								
D				APPROVAL: JC	UNIT: MM	WERI PART NO: DISCLAIMER	SIZE <b>A4</b>	
C					SCALE:			
B					SHEET: 3/3			
A	10-SEP-14	PDF	QL		DRAW: QL			
REV	DATE	FILE	BY					

D