

THIS DRAWING IS UNPUBLISHED. RELEASED FOR PUBLICATION
 © COPYRIGHT - BY - ALL RIGHTS RESERVED.

LOC	DIST	REVISIONS					
DW		P	LTR	DESCRIPTION	DATE	DWN	APVD
				SEE SHEET 1.			

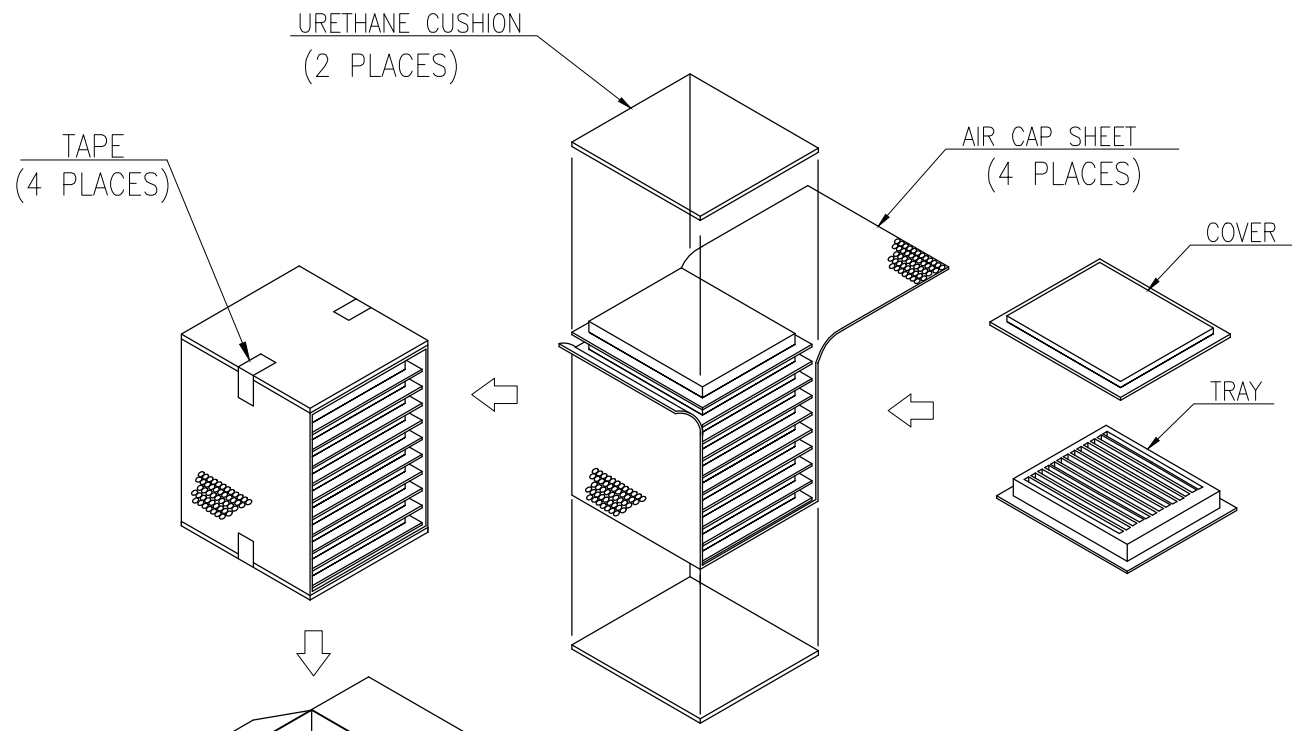

TAPE
(4 PLACES)

URETHANE CUSHION
(2 PLACES)

AIR CAP SHEET
(4 PLACES)

COVER

TRAY

- NOTES:
- MATERIAL:
 - 1.1 TRAY: PVC
 - 1.2 SHIPPING CARTON: CORRUGATED FIBERBOARD
 - DIMENSION:
 - 2.1 TRAY: L=320, W=230, H=18.9
 - 2.2 SHIPPING CARTON: L=361, W=245, H=272
 - QUANTITY:
 - 3.1 PRIMARY PACKING: 100 PCS/TRAY
 - 3.2 SECONDARY PACKING: 10 TRAY/CARTON(1000PCS)
 - CARTON WEIGHT:
 - 4.1 NET WEIGHT: 10.24 Kg (W/SCREWLOCK)
 - 4.2 GROSS WEIGHT: 11.24 Kg (W/SCREWLOCK)
 - 4.3 NET WEIGHT: 8.24 Kg (W/O SCREWLOCK)
 - 4.4 GROSS WEIGHT: 9.24 Kg (W/O SCREWLOCK)

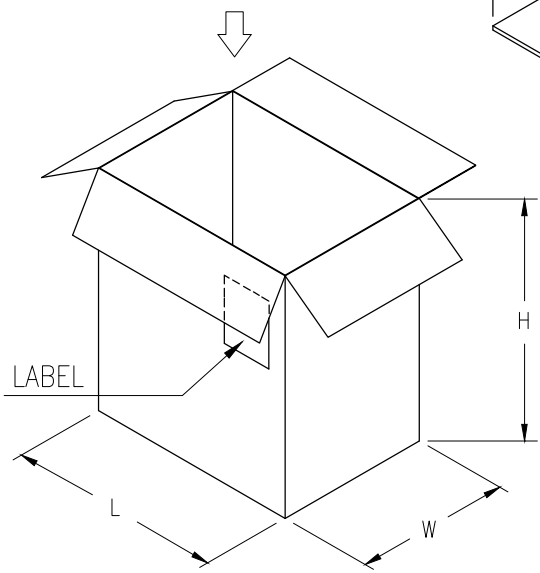

THIS DRAWING IS A CONTROLLED DOCUMENT.		DWN	TE TE Connectivity		
DIMENSIONS: MM		CHK			
TOLERANCES UNLESS OTHERWISE SPECIFIED:		APVD	NAME		
0 PLC ± -		PRODUCT SPEC		RECEPTACLE ASSY, SIZE 1, 15 POSITION, RIGHT ANGLE, THROUGH HOLE	
1 PLC ± -		APPLICATION SPEC		SIZE	RESTRICTED TO
2 PLC ± -		WEIGHT		A3	
3 PLC ± -		CUSTOMER DRAWING		CAGE CODE	DRAWING NO
4 PLC ± -				00779	C=1734530
ANGLES ± -				SCALE	
MATERIAL				SHEET 2 of 4	
FINISH				REV B3	

THIS DRAWING IS UNPUBLISHED. RELEASED FOR PUBLICATION
 © COPYRIGHT BY ALL RIGHTS RESERVED.

LOC DW	DIST	REVISIONS		
P	LTR	DESCRIPTION	DATE	DWN APVD
		SEE SHEET 1.		

D

D

C

C

B

B

A

A

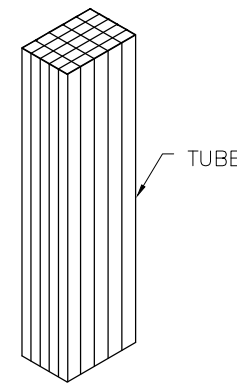
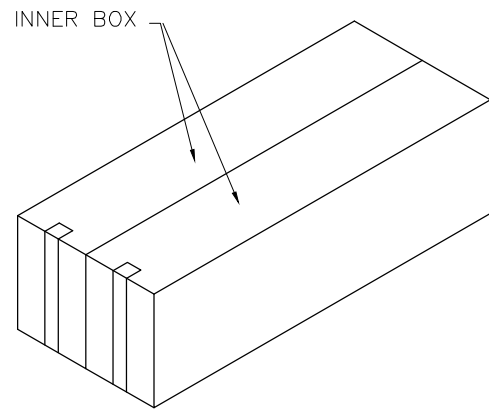

- NOTES:
- MATERIAL:
 - TUBE: PVC
 - SHIPPING CARTON: CORRUGATED FIBERBOARD
 - DIMENSION:
 - TUBE: L=560, W=17.8, H=27.4
 - SHIPPING CARTON: L=600, W=245, H=195
 - QUANTITY:
 - PRIMARY PACKING: 17 PCS/TUBE
 - SECONDARY PACKING: 25 TUBE/BOX
 - THIRD PACKING: 2 BOX/CARTON(850PCS)
 - CARTON WEIGHT:
 - NET WEIGHT: 8.7 Kg (W/O SCREWLOCK)
 - GROSS WEIGHT: 9.7 Kg (W/O SCREWLOCK)

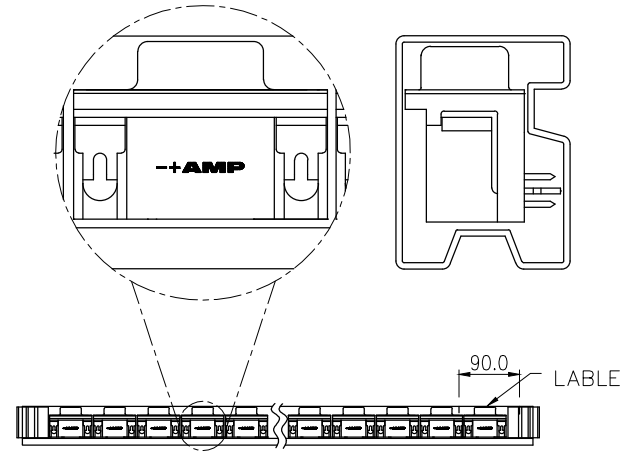
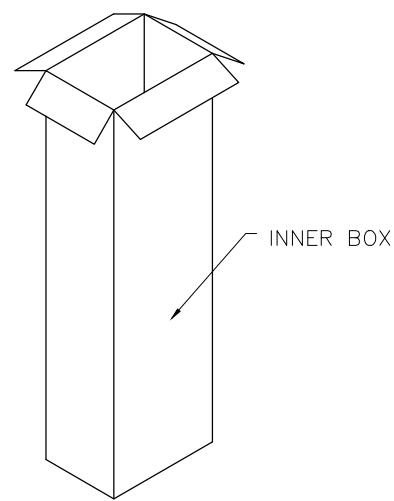
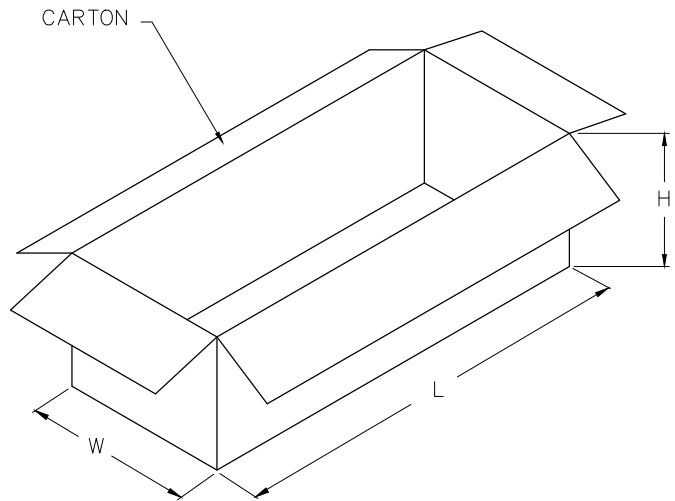

THIS DRAWING IS A CONTROLLED DOCUMENT.		DWN —		
DIMENSIONS: MM		CHK —		
TOLERANCES UNLESS OTHERWISE SPECIFIED:		APVD —	NAME	
0 PLC ± -		PRODUCT SPEC —	RECEPTACLE ASSY, SIZE 1, 15 POSITION, RIGHT ANGLE, THROUGH HOLE	
1 PLC ± -		APPLICATION SPEC —	SIZE	RESTRICTED TO
2 PLC ± -		WEIGHT —	A3	—
3 PLC ± -		CUSTOMER DRAWING	CAGE CODE	DRAWING NO
4 PLC ± -			00779	C=1734530
ANGLES ± -			SCALE	SHEET
MATERIAL	FINISH		—	3 of 4
				REV B3

THIS DRAWING IS UNPUBLISHED. RELEASED FOR PUBLICATION
 © COPYRIGHT BY ALL RIGHTS RESERVED.

LOC	DIST	REVISIONS					
DW		P	LTR	DESCRIPTION	DATE	DWN	APVD
		SEE SHEET 1.					

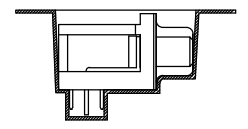
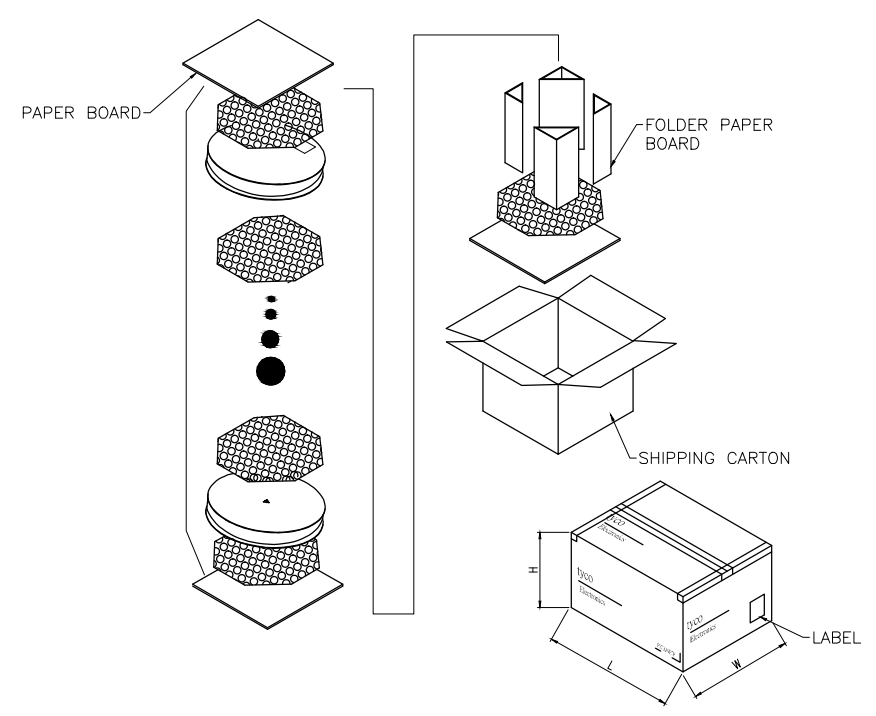
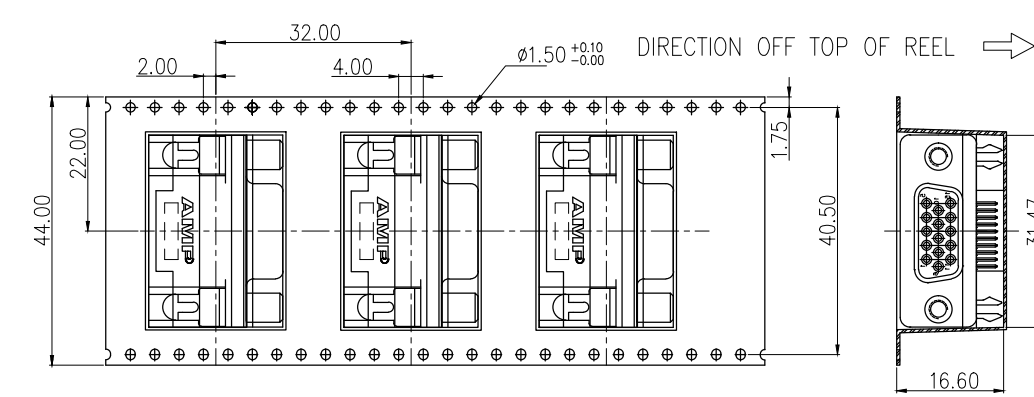
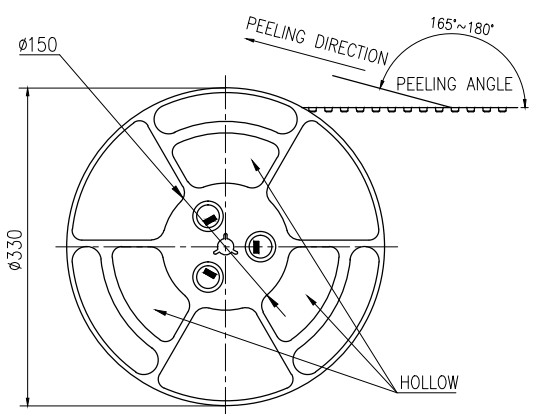
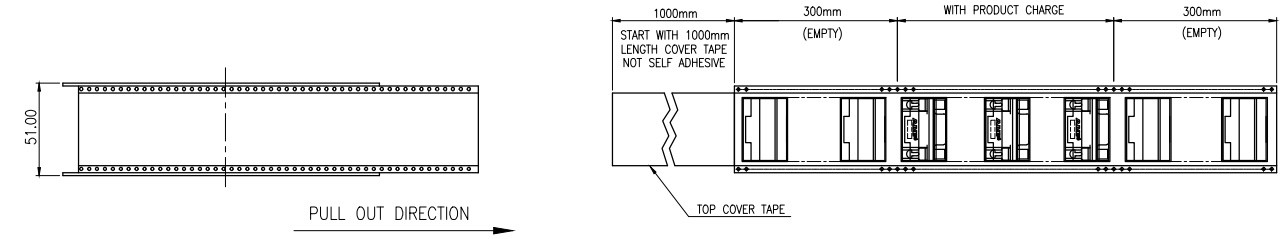

PRODUCT TYPE	PCS/REEL	REEL/CARTON	TOTAL(PCS)	CTN SIZE (CM)	NW(Kg)	GW(Kg)
D-SUB H/D 15P	100	6	600	360X360X350	5.4	5.9

THIS DRAWING IS A CONTROLLED DOCUMENT.

DIMENSIONS: MM	TOLERANCES UNLESS OTHERWISE SPECIFIED:	DWN	TE Connectivity				
0 PLC ± - 1 PLC ± - 2 PLC ± - 3 PLC ± - 4 PLC ± - ANGLES ± -		CHK	RECEPTACLE ASSY, SIZE 1, 15 POSITION, RIGHT ANGLE, THROUGH HOLE				
MATERIAL	FINISH	APVD	NAME	SIZE	CAGE CODE	DRAWING NO	RESTRICTED TO
		PRODUCT SPEC		A3	00779	C=1734530	
		APPLICATION SPEC		CUSTOMER DRAWING			SCALE
		WEIGHT		SHEET 4 of 4			REV B3