

RECOMMENDED P.C. BOARD LAYOUT

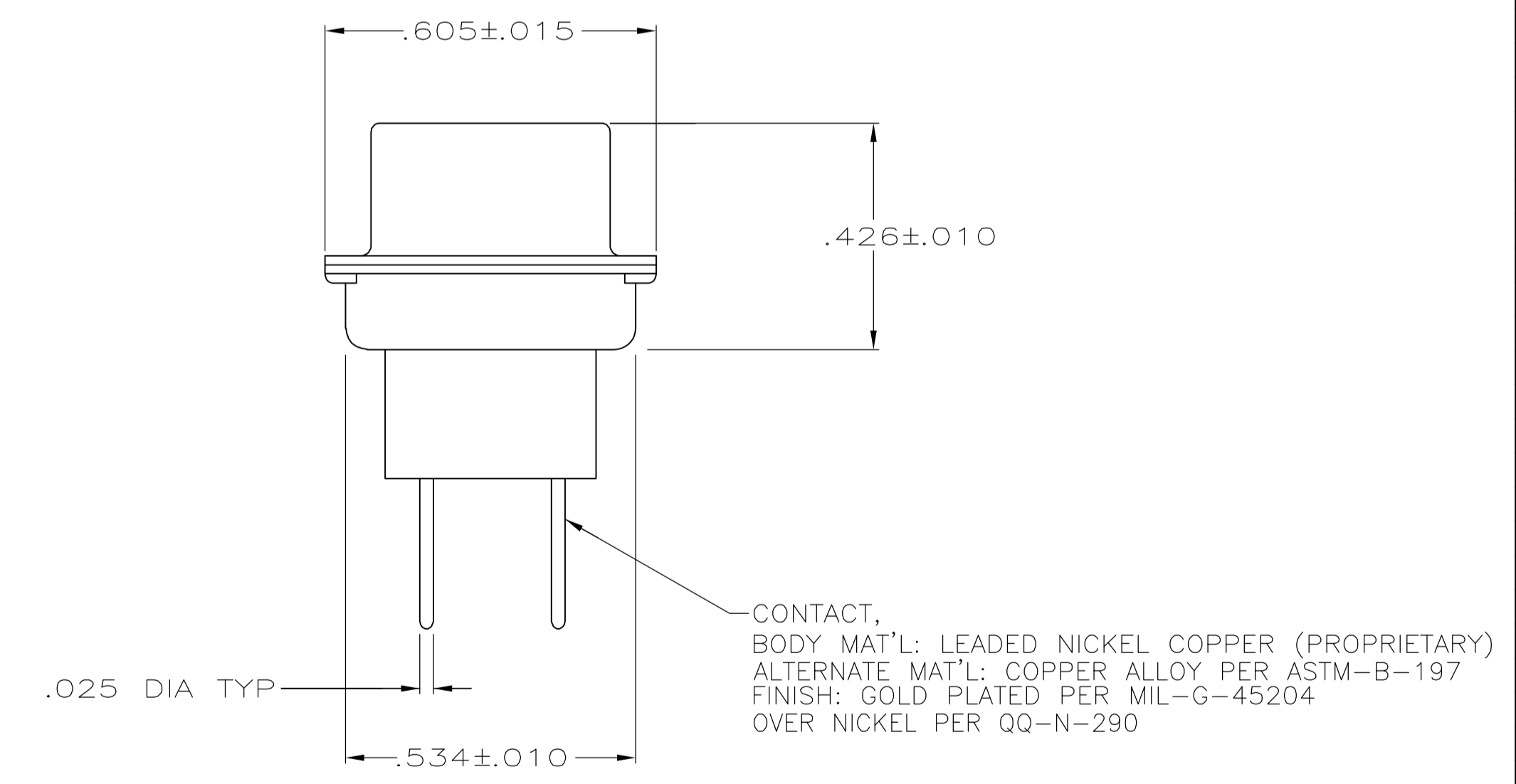
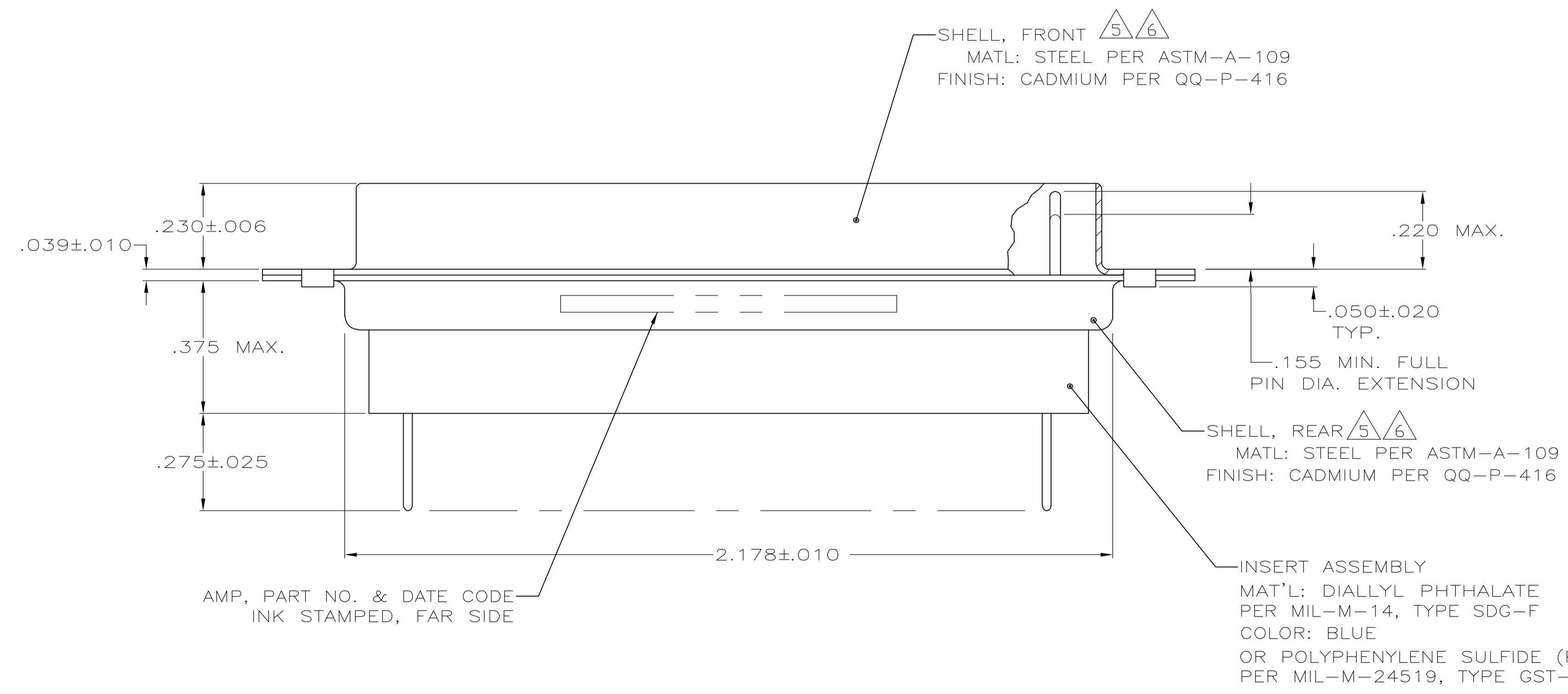

- .040 DIA HOLE IS RECOMMENDED FOR P.C. BOARD.
  - CONNECTOR MATES WITH ANY AMP 78 POSN RECEPTACLE.
  - REPLACEMENT CONTACT AMP# 207683-8.
- 4 UL/CSA DESIGNATION STAMPED IN THIS AREA.
- 5 CADMIUM PER QQ-P-416.
- 6 FINISH: ZINC PER ASTM-B-633 .000200-.000400 THK WITH SUPPLEMENTARY CHROMATE (Cr3+).

6	5-208870-1
5	208870-1
REMARKS	PART NO

THIS DRAWING IS A CONTROLLED DOCUMENT.		DIN C.C.THOMAS 1-12-88	Tyco Electronics Corporation Harrisburg, PA 17105-3608	
DIMENSIONS: INCHES		CHK F.C.BALLEW III	APVD	
TOLERANCES UNLESS OTHERWISE SPECIFIED:		PRODUCT SPEC		
0 PLC ± -		APPLICATION SPEC		
1 PLC ± -		SIZE		
2 PLC ± -		CAGE CODE		
3 PLC ± .005		DRAWING NO		
4 PLC ± -		RESTRICTED TO		
ANGLES ± -		A1 00779 C=208870		
MATERIAL SEE CALLOUTS		WEIGHT		CUSTOMER DRAWING
FINISH SEE CALLOUTS		SCALE 4:1		SHEET 1 OF 1 REV J