



Test Procedure for the NCP1075PSRGEVB Evaluation Board

Introduction: The NCP1075 Primary Sensed EVAL demo board is a universal input, off-line, 10 watt output, constant voltage power supply for powering E-meters or white goods applications where tight output voltage regulation is not necessary. This version of the NCP1075 flyback circuit does not have voltage sensing on the secondary side but utilizes the aux winding on the primary side of the transformer for sensing an analog of Vout. This eliminates the use of an NCP431 and optocoupler in the feedback loop. This demo board has an output rating of 12 volts at 0.75 amps max.

Equipment Required:

1. Adjustable, isolated AC power source capable of zero to 265 Vac output up to 500 mA. AC source should have the capability of measuring input power in watts. If not, an AC line analyzer or AC wattmeter should be used. Wattmeter should be capable of reading down to 50 mW (for standby power measurements.)
2. Digital volt/amp meters to measure output current and voltage to the electronic load.
3. A variable electronic load or rheostat capable of up to a 3 amp load. If an electronic load is used it is preferable to have a constant resistance load mode. The current meter on the electronic load can be used in lieu of a series, in-line ammeter.
4. Oscilloscope with probe to monitor output ripple on the demo converter.

Setup Procedure: Set the equipment as shown in the diagram below so that the output voltage and current to the demo board can be measured and the output ripple can be monitored.

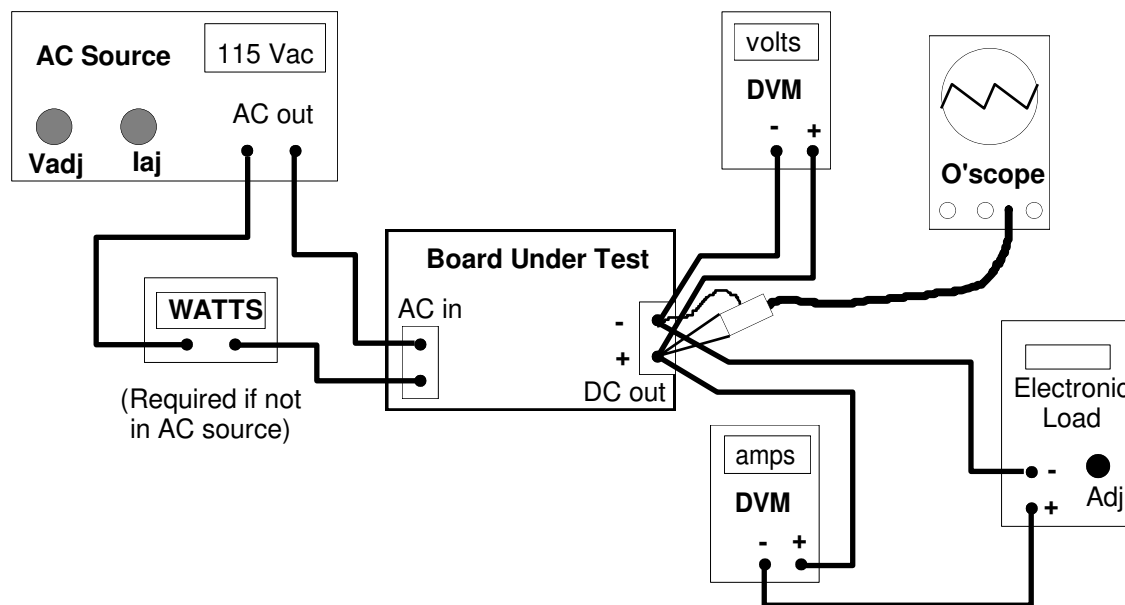

Note: Indicated output polarity on above drawing of demo board may not correspond to actual demo board. Please note output polarity as marked on demo board behind the output terminal strip.

**Test Procedure:**

1. Switch the electronic load on and set to zero load; switch all of the digital meters on (assuming they are wired properly for voltage and current sensing); turn the oscilloscope on with sensing in AC mode and 100 mV per division vertical and a sweep rate of 5 uS per division. Connect the scope probe to the demo board's output terminals.
2. With the AC source OFF, set the current limit on the AC source to 250 mA and the output voltage to 120 Vac.
3. Turn on the AC source and the power supply output voltage should be approximately 14 to 15 volts max with no load.
4. Adjust the electronic load from no load slowly up to 50 mA (min load). The output voltage should be between 11.5 volts and 13 volts.
5. Increase the output load to 750 mA and the output voltage should be 11.0 volts or greater but not over 13 volts. The output ripple should be less than 120 mV peak to peak.
6. Adjust the AC source down to 90 Vac and the power supply output should still be within 100 mV of the reading in step 5. Return the AC source to 120 Vac.
7. While at full load (750 mA), check the efficiency. $\text{Effic} = (\text{Vout} \times \text{Iout})/\text{Pin}$. It should be greater than 75%.
8. Continue to increase the load slowly and the over-current protection should kick in between 1 and 2 amps. This should result in a "hick-up" start-stop type of operation or a de-regulation of Vout below nominal, particularly with 240Vac input.
9. Set the load back to 0.75 amps and the power supply should recover with proper output voltage.
10. Adjust the AC input to 230 Vac and repeat tests (3) through (8) with the exception of #6.
11. Switch the AC source off and disconnect the demo board.

End of Test.