

PART NUMBER	REVISION	DESCRIPTION	FEED TYPE
2151494-1	T	FINE CRIMP HEIGHT ADJUST	MECHANICAL
2151494-2	T	FINE CRIMP HEIGHT ADJUST	PNEUMATIC
5-2151494-1	T	SEAL STRIPPER CRIMPER TERMINATING UNIT	MECHANICAL
5-2151494-2	T	SEAL STRIPPER CRIMPER TERMINATING UNIT	PNEUMATIC
7-2151494-1	T	MECHANICAL AND CRIMP TOOLING KIT	MECHANICAL
7-2151494-2	T	PNEUMATIC AND CRIMP TOOLING KIT	PNEUMATIC
7-2151494-7	J	CRIMP TOOLING KIT	-

ATLANTIC VERSION TERMINATOR INTERFACE ADAPTER

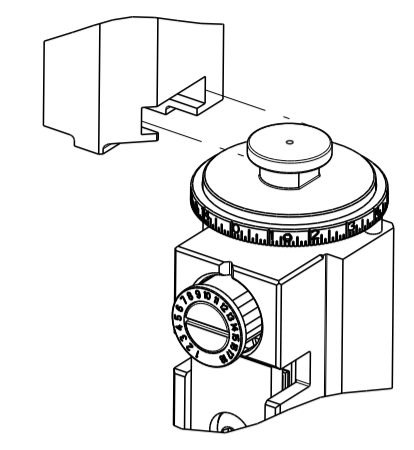

APPLICATOR DATA		
CRIMP	SIZE	TYPE
WIRE	1.40 mm [.055]	F
INSUL	1.40 mm [.055]	F

APPLICATOR INSTRUCTIONS 408-35042

TERMINAL DATA: TE TERMINAL TE CRIMP SPECIFICATION			
TERMINAL NAME: 025 RECEPTACLE CONTACT			
WIRE STRIP LENGTH	INSULATION DIAMETER RANGE		
3.00-3.50 mm [.118-.138 IN]	Ø0.95-1.70 mm [.037-.067 IN]		
TERMINAL APPLICATION SPECIFICATION (A)114-5250	-		
TERMINAL APPLICATION SPECIFICATION (B)114-5291	-		
TERMINALS APPLIED 5			
TE TERMINAL (A) 1123343-1	TE TERMINAL (A) 1123343-2	TE TERMINAL (B) 1376109-1	TE TERMINAL (B) 1376109-2

TERMINAL DATA: TE TERMINAL TE CRIMP SPECIFICATION			
TERMINAL NAME: 025 RECEPTACLE CONTACT			
WIRE STRIP LENGTH	INSULATION DIAMETER RANGE		
3.00-3.50 mm [.118-.138 IN]	Ø0.95-1.70 mm [.037-.067 IN]		
TERMINAL APPLICATION SPECIFICATION (C)114-5250-2	-		
TERMINAL APPLICATION SPECIFICATION	-		
TERMINALS APPLIED 5			
TE TERMINAL (C) 1674298-1	TE TERMINAL (C) 2005427-1	TE TERMINAL (C) 2188446-2	

TERMINAL DATA: TE TERMINAL TE CRIMP SPECIFICATION			
TERMINAL NAME: 025 RECEPTACLE CONTACT			
WIRE STRIP LENGTH	INSULATION DIAMETER RANGE		
3.00-3.50 mm [.118-.138 IN]	Ø1.20-1.60 mm [.047-.063 IN]		
TERMINAL APPLICATION SPECIFICATION 114-15120	-		
TERMINAL APPLICATION SPECIFICATION	-		
TERMINALS APPLIED 5			
TE TERMINAL 1674298-1	TE TERMINAL 1123343-1	TE TERMINAL 1122343-2	TE TERMINAL 1802189-1
1801069-2			

WIRE SIZE	CRIMP HEIGHT mm [INCH]	CRIMP HEIGHT REFERENCE SETTING
0.50mm2	1.06+/-0.05 [.042+/- .002]	8.5
0.30mm2	0.96+/-0.05 [.038+/- .002]	9.2
0.22mm2	0.84+/-0.05 [.033+/- .002]	10.0

WIRE SIZE	CRIMP HEIGHT mm [INCH]	CRIMP HEIGHT REFERENCE SETTING
0.50mm2	1.01+/-0.05 [.040+/- .002]	8.5
0.30mm2	0.96+/-0.05 [.038+/- .002]	9.2
0.22mm2	0.84+/-0.05 [.033+/- .002]	10.0

WIRE SIZE	CRIMP HEIGHT mm [INCH]	CRIMP HEIGHT REFERENCE SETTING
0.50mm2	0.99+/-0.05 [.039+/- .002]	8.5
0.35mm2	0.92+/-0.05 [.036+/- .002]	9.3
0.22mm2	0.84+/-0.05 [.033+/- .002]	10.0

- 1 RECOMMENDED SPARE PARTS
- 2 REFER TO SUPPLIED INSTRUCTION SHEET FOR CLEANING, LUBRICATION AND STORAGE OF APPLICATOR.
- 3 APPLY PART NUMBER 1-23419-5 LOCTITE TO THREADS OF ITEMS 180. APPLY PART NUMBER 2-23419-6 LOCTITE TO THREADS OF ITEM 242.
- 4 CRIMP HEIGHT REFERENCE SETTING WAS THE SETTING USED WHEN THE APPLICATOR WAS QUALIFIED AT THE FACTORY. ADJUSTMENT MAY BE NECESSARY WHEN RUNNING APPLICATOR IN THE FIELD.
- 5 TERMINAL LUBRICANT IS RECOMMENDED.
- 6. UNLESS SPECIFIED OTHERWISE TORQUE VALUES SHALL BE USED PER DOCUMENT, 101-35000.
- 7 APPLICATION SPECIFICATION 114-15120 IS RESTRICTED TO RENAULT AND ITS HARNESS MAKERS.

***WARNING**
 ON INSTALLATION, SET WIRE DISC TO CRIMP HEIGHT REFERENCE SETTING FOR LARGEST WIRE SIZE. CRIMP HEIGHT REFERENCE SETTINGS GREATER THAN THE VALUE SHOWN MAY CAUSE DAMAGE TO THE CRIMP TOOLING, REFER TO THE INSTRUCTION SHEET FOR PROPER SETUP AND ADJUSTMENTS.

LOC	DIST	REVISIONS					
A	66	P	LTN	DESCRIPTION	DATE	OWN	APVD
		T		ECR-22-130688	25FEB2022	FZ	JH
		T1		ECR-22-133359	22MAR2022	FZ	YY
		T2		ECR-22-160755	08DEC2022	JWC	TE
		T3		ECR-23-164150	18JAN2023	JWC	TE

-	-	-	1	1	-	-	1803515-3	RAM ASSEMBLY, SF ATLANTIC	293
-	-	-	1	1	-	-	2-1803583-1	APPLICATOR BASIC ASSEMBLY, SF	292
-	1	-	1	-	1	-	2119641-1	FEED CAM, AIR FEED	248
-	1	1	1	1	1	1	2119082-5	CAM, SNAIL, INSULATION ADJUSTMENT	244
-	1	1	1	1	1	1	2079764-1	WASHER, WAVE SPRING, CREST-TO-CREST	243
-	1	1	1	1	1	1	2119083-1	RETAINER, INSULATION DIAL	242
-	1	1	1	1	1	1	7-18023-7	SCR, SKT HD CAP M3 X 4.0	241
-	-	1	-	1	-	1	2119580-1	MECHANICAL FEED ASSEMBLY	239
-	1	-	1	-	1	-	2844940-1	AIR FEED MODULE	238
-	-	-	1	1	-	-	4-1722335-3	STRIPPER, SIDE FEED	182
-	-	-	1	1	-	-	1-5018030-0	NUT, HEX, REG, RoHS, M3.5	181
-	-	-	1	1	-	-	1-1752354-6	STANDOFF, HOLD-DOWN	180
-	-	-	1	1	-	-	9931111-1	PIN, SLOTTED SPRING 3.0 X 20.0	177
-	-	-	1	1	-	-	5-22280-0	SPRING, COMPRESSION	176
-	-	-	1	1	-	-	1752353-3	GUIDE PIN, HOLDDOWN	175
-	-	-	1	1	-	-	1901680-2	GUIDE PIN, HOLDDOWN	174
-	REF	REF	REF	REF	REF	REF	994970-2	COUNTER, MAGNETIC	164
-	1	1	1	1	1	1	2119955-1	ASSY, LUBRICATOR, SIDE FEED	113
-	1	1	1	1	1	1	2844908-1	SCREW, LOCKING	99
-	1	1	1	1	1	1	2844907-1	POST, LOCKING	98
-	1	1	1	1	1	1	455888-4	SPACER, CRIMPER	82
-	1	1	1	1	1	1	1803607-3	DOCUMENTATION PACKAGE	71
-	1	1	1	1	1	1	2119791-9	DEPRESSOR, WIRE	70
-	1	1	1	1	1	1	2119740-1	TAG, IDENTIFICATION	67
-	2	2	2	2	2	2	2168078-1	SCREW, DRIVE, RH, RoHS, 2 x .188	66
-	1	1	1	1	1	1	2168083-2	SCR, SKT HD CAP, RoHS, M4 X 8.0	60
-	1	1	1	1	1	1	5-18022-5	SCR, HEX HD CAP, M4 X 6.0	59
-	1	1	1	1	1	1	1338685-1	PAWL, FEED	56
-	4	4	4	4	4	4	2168083-3	SCR, SKT HD CAP, RoHS, M4 X 12.0	54
-	2	2	2	2	2	2	2-2168083-5	SCR, SKT HD CAP, RoHS, M4 X 14	53
-	1	1	1	1	1	1	1803382-6	HOLD DOWN, SPRING LOADED	50
-	1	2	1	2	1	2	18023-9	SCR, SKT HD CAP M4 X 6.0	49
-	-	1	-	1	-	1	2119652-1	FEED CAM, PRE FEED	48
-	-	1	-	1	-	1	2119653-1	FEED CAM, POST FEED	47
-	1	1	-	-	1	1	1803583-9	APPLICATOR BASIC ASSEMBLY, SF	46
-	1	1	-	-	1	1	1803515-1	RAM ASSEMBLY, SF ATLANTIC	44
-	1	1	1	1	1	1	1803602-1	SCR, BHSC, RoHS (M8 X 25)	41
-	1	1	1	1	1	1	1752356-3	SUPPORT, TERMINAL	34
-	2	2	2	2	2	2	2079383-5	SCR, BHSC, RoHS (M4 X 20)	33
-	2	2	2	2	2	2	2-2844962-4	SPACER, CYLINDRICAL, STRIP GUIDE	30
-	1	1	1	1	1	1	2844992-1	ASSEMBLY, STRIP GUIDE	29
-	1	1	1	1	1	1	1320928-2	STRIP GUIDE	24
-	1	1	-	-	1	1	2168083-2	SCR, SKT HD CAP, RoHS, M4 X 8.0	21
-	2	2	1	1	2	2	1-18028-2	WASHER, FLAT, REG M4	20
-	1	1	-	-	1	1	2119533-1	STRIPPER, SIDE FEED	19
-	1	1	1	1	1	1	2119806-1	INSERT, SHEAR	13
-	1	1	1	1	1	1	3-22280-3	SPRING, COMPRESSION	12
-	1	1	1	1	1	1	1-356885-4	STOP, SHEAR	11
-	1	1	1	1	1	1	2119805-1	SHEAR HOLDER, FRONT	10
-	1	1	1	1	1	1	1803095-3	FLOATING SHEAR, FRONT	9
1	2	2	1	1	1	1	8-1333201-3	ANVIL, COMBINATION	8
-	1	1	1	1	1	1	1-240641-2	SPACER	7
-	1	1	1	1	1	1	1-2119757-1	DEPRESSOR, SHEAR	5
-	1	1	1	1	1	1	1-238011-0	BLOCK, CRIMPER SPACER	4
1	2	2	1	1	1	1	2-1803223-6	CRIMPER, INSULATION F PREMIUM	3
-	1	1	1	1	1	1	455888-1	SPACER, CRIMPER	2
1	2	2	1	1	1	1	3-456402-5	CRIMPER, WIRE PREMIUM	1

ATLANTIC VERSION
 Shown on sheets 1 of 4 & 2 of 4
 (Pacific version shown on sheets 3 of 4 & 4 of 4)

DIMENSIONS:		TOLERANCES UNLESS OTHERWISE SPECIFIED:		DRAWN BY: WEAVER 11OCT2011		CHK: G. HOFENER 11OCT2011		APVD: G. RALLEY 11OCT2011		NAME: Ocean Side Feed Applicator	
mm		0 PLC ±		1 PLC ±		3 PLC ±		4 PLC ±		RESTRICTED TO	
MATERIAL:		FINISH:		WEIGHT:		SCALE: 1:2		SHEET 1 OF 4		REV T3	

Customer Accessible Production Drawing

LOC	DIST	REVISIONS					
A	66	P	LYN	DESCRIPTION	DATE	OWN	APVD
		-		SEE SHEET 1	-	-	-

FEED TYPE MECHANICAL

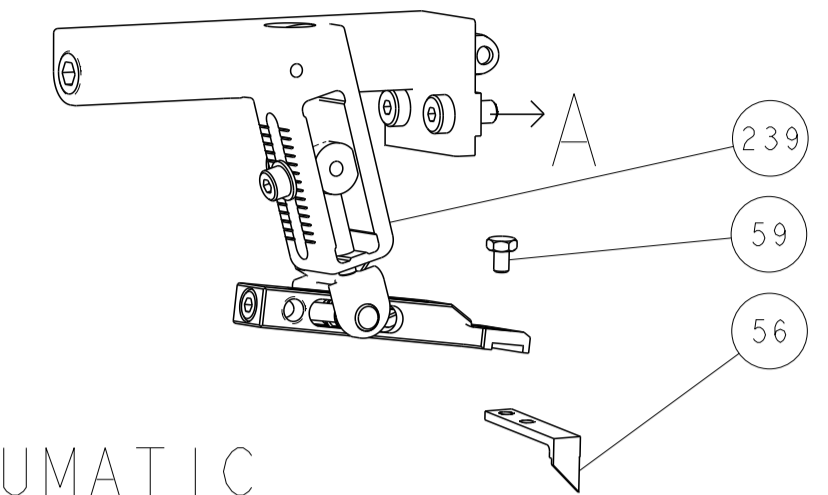

PNEUMATIC

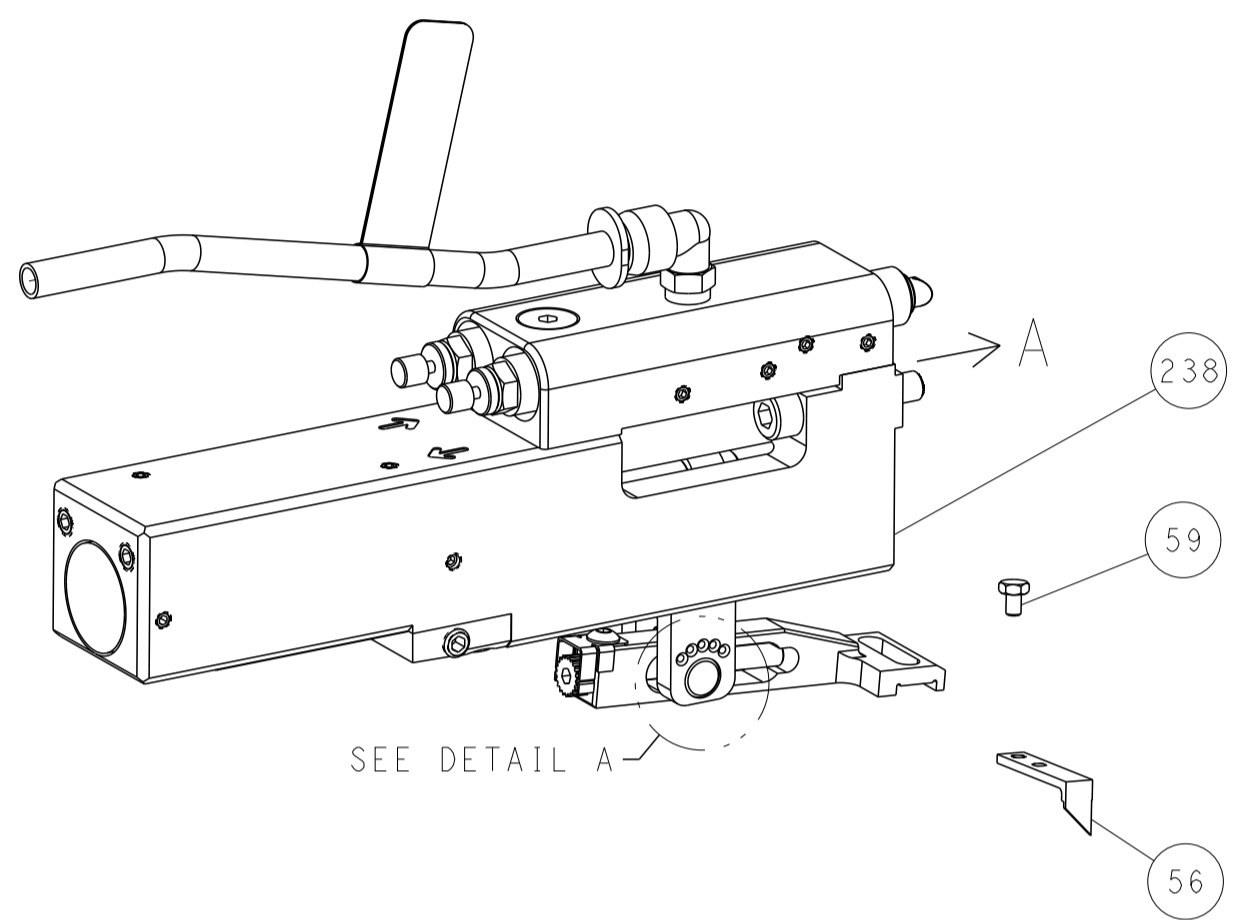

FEED SPRING SETTING POSITION (SHOWN FROM REAR SIDE)

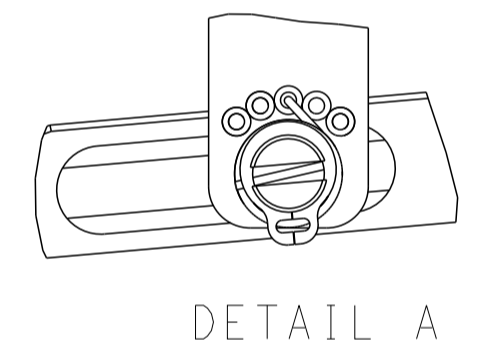

DETAIL A

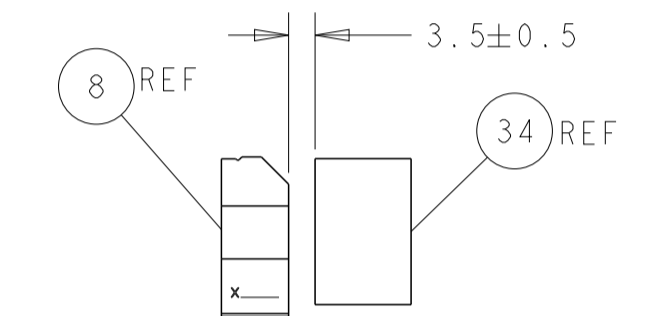
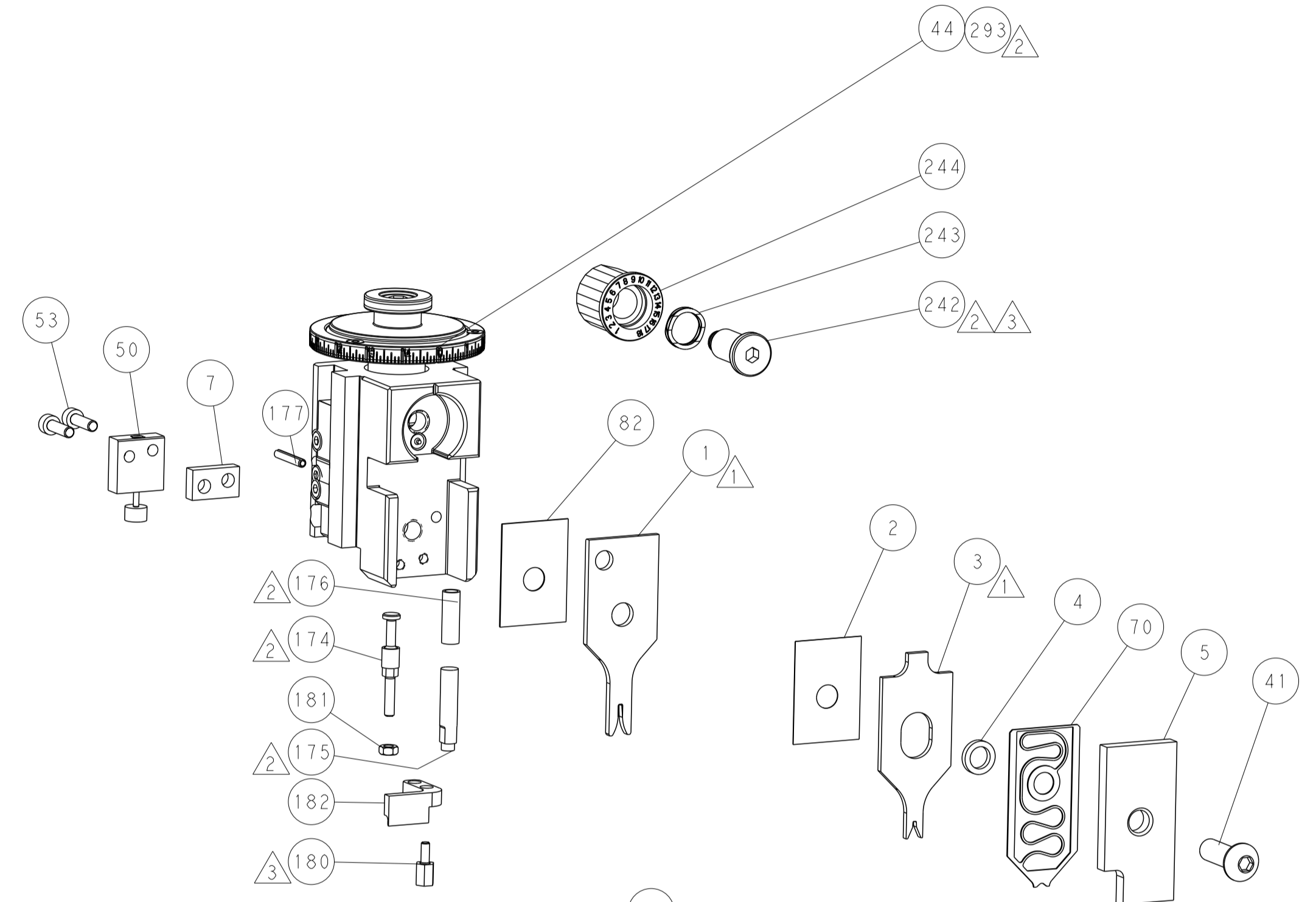

TERMINAL SUPPORT LOCATION

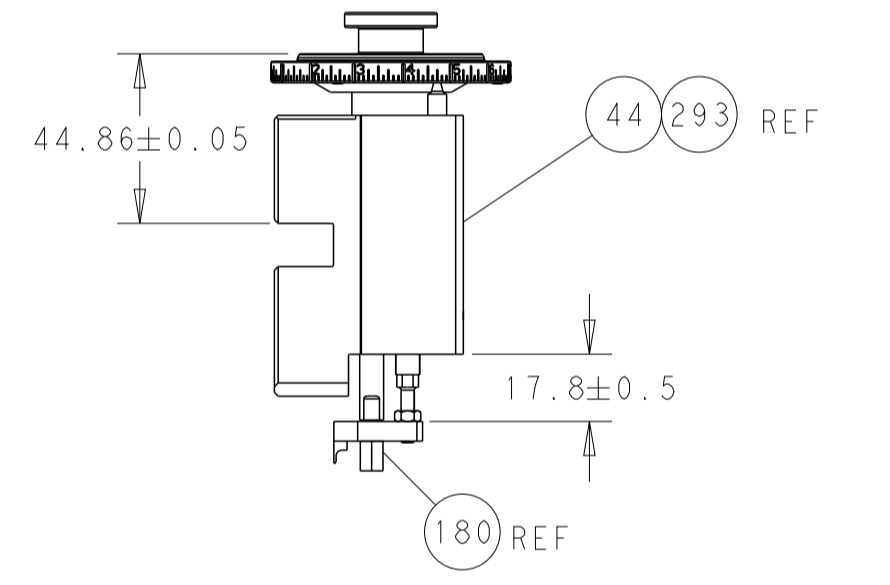

RAM AND HOLD DOWN SET-UP

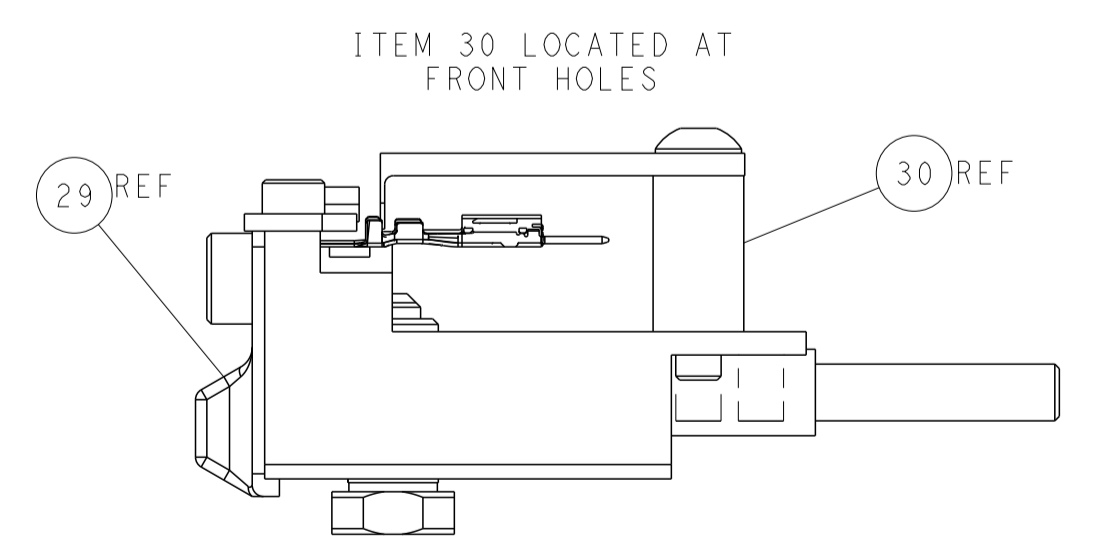
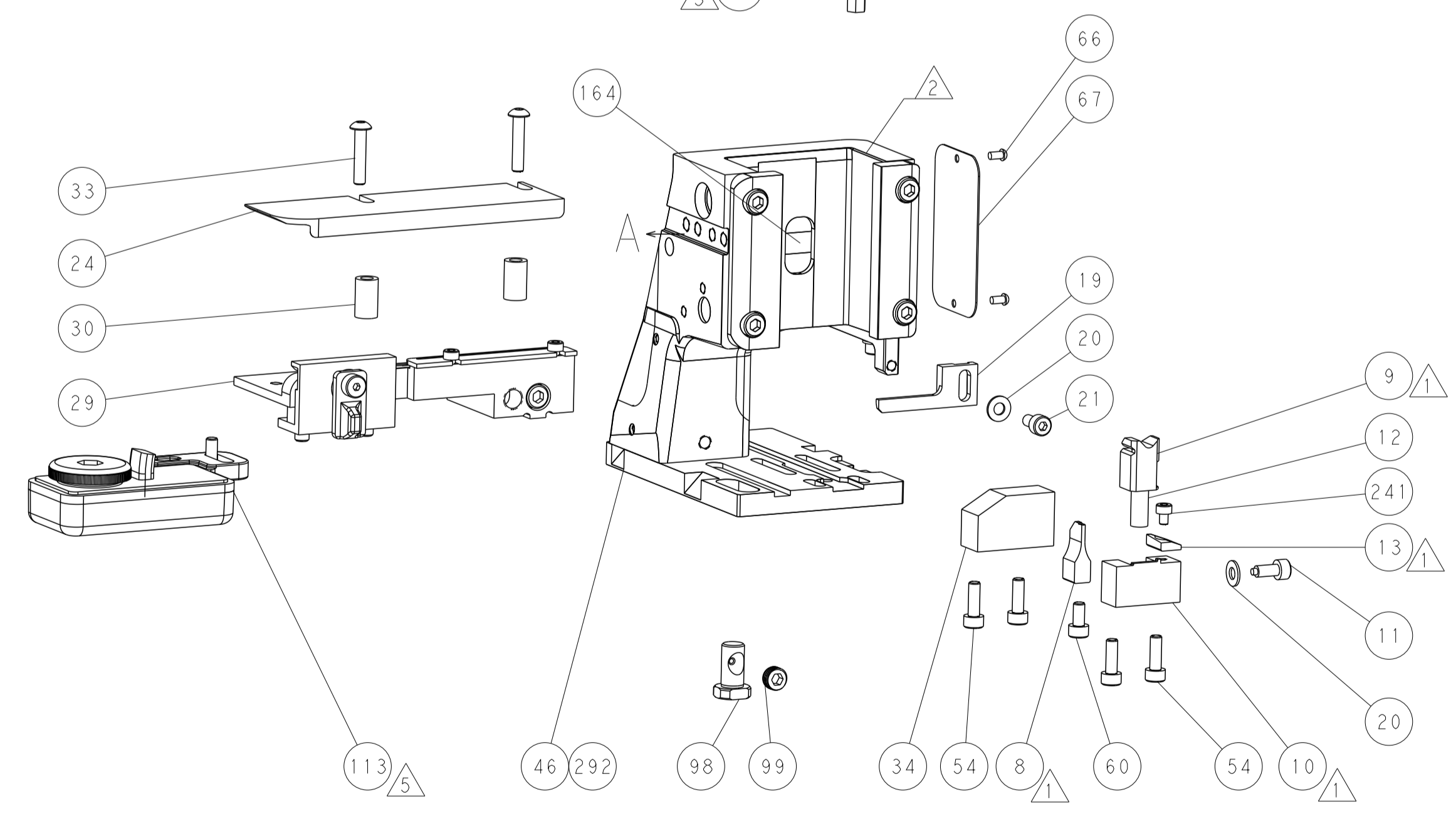

FEED TRACK POSITION GUIDE BY INSULATION BARREL

CAM POSITIONS

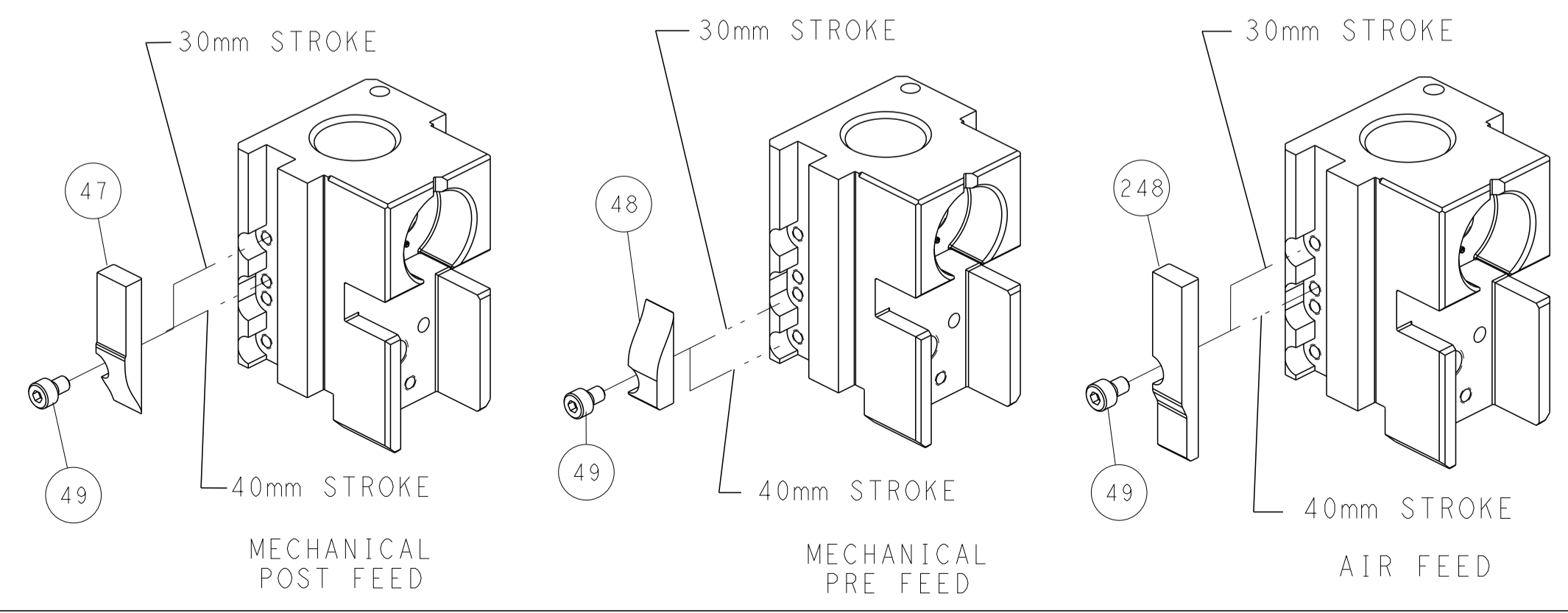

ATLANTIC VERSION
 Shown on sheets 1 of 4 & 2 of 4
 (Pacific version shown on sheets 3 of 4 & 4 of 4)

DIMENSIONS:		TOLERANCES UNLESS OTHERWISE SPECIFIED:		OWN: B. WEAVER 11OCT2011	TE Connectivity Harrisburg, PA 17105-3608
mm	0 PLC ±	1 PLC ±	2 PLC ±	CHK: G. HOFNER 11OCT2011	
MATERIAL:		FINISH:		APVD: G. RALLEY 11OCT2011	NAME: Ocean Side Feed Applicator
				PRODUCT SPEC:	SIZE: CAGE CODE: DRAWING NO: RESTRICTED TO:
				APPLICATION SPEC:	A1 00779 ©=2151494
				WEIGHT:	Customer Accessible Production Drawing
				SCALE: 1:2	SHEET 2 OF 4 REV 3

PART NUMBER	REVISION	DESCRIPTION	FEED TYPE
2-2151494-1	T	FINE CRIMP HEIGHT ADJUST	MECHANICAL
2-2151494-2	T	FINE CRIMP HEIGHT ADJUST	PNEUMATIC
7-2151494-7	J	CRIMP TOOLING KIT	-

PACIFIC VERSION TERMINATOR
INTERFACE ADAPTER

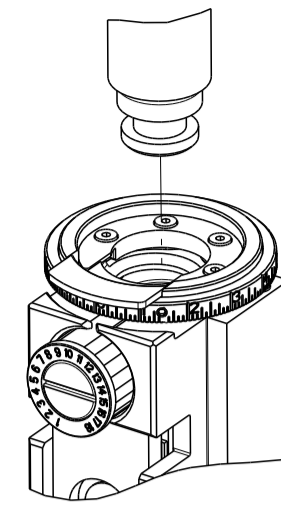

APPLICATOR DATA		
CRIMP	SIZE	TYPE
WIRE	1.40 mm [.055]	F
INSUL	1.40 mm [.055]	F

APPLICATOR INSTRUCTIONS
408-35042

TERMINAL DATA: TE TERMINAL		TE CRIMP SPECIFICATION	
TERMINAL NAME: 025 RECEPTACLE CONTACT			
WIRE STRIP LENGTH		INSULATION DIAMETER RANGE	
3.00-3.50 mm [.118-.138 IN]		Ø0.95-1.70 mm [.037-.067 IN]	
TERMINAL APPLICATION SPECIFICATION	(A) 114-5250	-	-
	(B) 114-5291	-	-
TERMINALS APPLIED			
TE TERMINAL	TE TERMINAL	TE TERMINAL	TE TERMINAL
(A) 1123343-1	(A) 1123343-2	(B) 1376109-1	(B) 1376109-2

TERMINAL DATA: TE TERMINAL		TE CRIMP SPECIFICATION	
TERMINAL NAME: 025 RECEPTACLE CONTACT			
WIRE STRIP LENGTH		INSULATION DIAMETER RANGE	
3.00-3.50 mm [.118-.138 IN]		Ø0.95-1.70 mm [.037-.067 IN]	
TERMINAL APPLICATION SPECIFICATION	(C) 114-5250-2	-	-
TERMINALS APPLIED			
TE TERMINAL	TE TERMINAL	TE TERMINAL	TE TERMINAL
(C) 1674298-1	(C) 2005427-1	(C) 2188446-2	

TERMINAL DATA: TE TERMINAL		TE CRIMP SPECIFICATION	
TERMINAL NAME: 025 RECEPTACLE CONTACT			
WIRE STRIP LENGTH		INSULATION DIAMETER RANGE	
3.00-3.50 mm [.118-.138 IN]		Ø1.20-1.60 mm [.047-.063 IN]	
TERMINAL APPLICATION SPECIFICATION	114-15120	-	-
TERMINALS APPLIED			
TE TERMINAL	TE TERMINAL	TE TERMINAL	TE TERMINAL
1674298-1	1123343-1	1122343-2	1802189-1
1801069-2			

WIRE SIZE	CRIMP HEIGHT mm [INCH]	CRIMP HEIGHT REFERENCE SETTING
0.50mm2	1.06+/-0.05 [.042+/-0.002]	8.5
0.30mm2	0.96+/-0.05 [.038+/-0.002]	9.2
0.22mm2	0.84+/-0.05 [.033+/-0.002]	10.0

WIRE SIZE	CRIMP HEIGHT mm [INCH]	CRIMP HEIGHT REFERENCE SETTING
0.50mm2	1.01+/-0.05 [.040+/-0.002]	8.5
0.30mm2	0.96+/-0.05 [.038+/-0.002]	9.2
0.22mm2	0.84+/-0.05 [.033+/-0.002]	10.0

WIRE SIZE	CRIMP HEIGHT mm [INCH]	CRIMP HEIGHT REFERENCE SETTING
0.50mm2	0.99+/-0.05 [.039+/-0.002]	8.5
0.35mm2	0.92+/-0.05 [.036+/-0.002]	9.3
0.22mm2	0.84+/-0.05 [.033+/-0.002]	10.0

- 1 RECOMMENDED SPARE PARTS
- 2 REFER TO SUPPLIED INSTRUCTION SHEET FOR CLEANING, LUBRICATION AND STORAGE OF APPLICATOR.
- 3 APPLY PART NUMBER 2-23419-6 LOCTITE TO THREADS OF ITEM 242.
- 4 CRIMP HEIGHT REFERENCE SETTING WAS THE SETTING USED WHEN THE APPLICATOR WAS QUALIFIED AT THE FACTORY. ADJUSTMENT MAY BE NECESSARY WHEN RUNNING APPLICATOR IN THE FIELD.
- 5 TERMINAL LUBRICANT IS RECOMMENDED.
- 6. UNLESS SPECIFIED OTHERWISE TORQUE VALUES SHALL BE USED PER DOCUMENT, 101-35000.
- 7 APPLICATION SPECIFICATION 114-15120 IS RESTRICTED TO RENAULT AND ITS HARNESS MAKERS.

***WARNING**
ON INSTALLATION, SET WIRE DISC TO CRIMP HEIGHT REFERENCE SETTING FOR LARGEST WIRE SIZE. CRIMP HEIGHT REFERENCE SETTINGS GREATER THAN THE VALUE SHOWN MAY CAUSE DAMAGE TO THE CRIMP TOOLING, REFER TO THE INSTRUCTION SHEET FOR PROPER SETUP AND ADJUSTMENTS.

ENTRY LEVEL APPLICATOR		ITEM SUBSTITUTION LIST		
PART NUMBER	SAME AS	ITEM	ITEM DESCRIPTION	SUBSTITUTE PART NUMBER
8-2151494-1	2151494-1	1	WIRE CRIMPER	3-1803530-5
8-2151494-2	2151494-2	3	INSULATION CRIMPER	2-1803628-6
9-2151494-1	2-2151494-1	46	BASIC SUB -ASSEMBLY	1803940-9
9-2151494-2	2-2151494-2	141	BASIC SUB -ASSEMBLY	1-1803940-0
			LUBRICATOR	DELETE

PACIFIC VERSION
Shown on sheets 3 of 4 & 4 of 4
(Atlantic version shown on sheets 1 of 4 & 2 of 4)

LOC	DIST	REVISIONS					
A	66	P	LTN	DESCRIPTION	DATE	OWN	APVD
		-		SEE SHEET 1			

-	1	1	2119082-5	CAM, SNAIL, INSULATION ADJUSTMENT	244
-	1	1	2079764-1	WASHER, WAVE SPRING, CREST-TO-CREST	243
-	1	1	2119083-1	RETAINER, INSULATION DIAL	242
-	1	1	7-18023-7	SCR, SKT HD CAP M3 X 4.0	241
-	-	1	2119580-1	MECHANICAL FEED ASSEMBLY	239
-	1	-	2844940-1	AIR FEED MODULE	238
-	REF	REF	994970-2	COUNTER, MAGNETIC	164
-	1	-	2119641-2	FEED CAM, AIR FEED	151
-	1	1	2168083-8	SCR, SKT HD CAP, RoHS, M4 X 16	144
-	4	4	2168083-9	SCR, SKT HD CAP, RoHS, M4 X 20	143
-	-	1	2119653-2	FEED CAM, POST FEED	142
-	1	1	1-1803583-0	APPLICATOR BASIC ASSEMBLY, SF	141
-	1	1	1803516-1	RAM ASSEMBLY, SF PACIFIC	140
-	1	1	2119955-1	ASSY, LUBRICATOR, SIDE FEED	113
-	1	1	2844908-1	SCREW, LOCKING	99
-	1	1	2844907-1	POST, LOCKING	98
-	1	1	455888-4	SPACER, CRIMPER	82
-	1	1	1803607-3	DOCUMENTATION PACKAGE	71
-	1	1	2119791-9	DEPRESSOR, WIRE	70
-	1	1	2119740-1	TAG, IDENTIFICATION	67
-	2	2	2168078-1	SCREW, DRIVE, RH, RoHS, 2 x .188	66
-	1	1	5-18022-5	SCR, HEX HD CAP, M4 X 6.0	59
-	1	1	1338685-1	PAWL, FEED	56
-	2	2	2-2168083-5	SCR, SKT HD CAP, RoHS, M4 X 14	53
-	1	1	1803382-6	HOLD DOWN, SPRING LOADED	50
-	1	2	18023-9	SCR, SKT HD CAP M4 X 6.0	49
-	-	1	2119652-1	FEED CAM, PRE FEED	48
-	1	1	1803602-1	SCR, BHSC, RoHS (M8 X 25)	41
-	1	1	1752356-3	SUPPORT, TERMINAL	34
-	2	2	2079383-5	SCR, BHSC, RoHS (M4 X 20)	33
-	2	2	2-2844962-4	SPACER, CYLINDRICAL, STRIP GUIDE	30
-	1	1	2844992-1	ASSEMBLY, STRIP GUIDE	29
-	1	1	1320928-2	STRIP GUIDE	24
-	1	1	2168083-2	SCR, SKT HD CAP, RoHS, M4 X 8.0	21
-	2	2	1-18028-2	WASHER, FLAT, REG M4	20
-	1	1	2119533-1	STRIPPER, SIDE FEED	19
-	1	1	2119806-1	INSERT, SHEAR	13
-	1	1	3-22280-3	SPRING, COMPRESSION	12
-	1	1	1-356885-4	STOP, SHEAR	11
-	1	1	2119805-1	SHEAR HOLDER, FRONT	10
-	1	1	1803095-3	FLOATING SHEAR, FRONT	9
-	1	1	1-240641-2	SPACER	7
-	1	1	1-2119757-1	DEPRESSOR, SHEAR	5
-	1	1	1-238011-0	BLOCK, CRIMPER SPACER	4
-	1	1	2-1803223-6	CRIMPER, INSULATION F PREMIUM	3
-	1	1	455888-1	SPACER, CRIMPER	2
-	1	1	3-456402-5	CRIMPER, WIRE PREMIUM	1

DIMENSIONS:		TOLERANCES UNLESS OTHERWISE SPECIFIED:		MATERIAL:	
mm	0 PLC ±	1 PLC ±	2 PLC ±	3 PLC ±	4 PLC ±
	ANGLES ±	FINISH ±			

OWN	CHK	DATE	NAME
B. WEAVER	G. HOFFNER	11OCT2011	G. RILEY

SIZE	CAGE CODE	DRAWING NO	RESTRICTED TO
A1	00779	2151494	

Customer Accessible Production Drawing SCALE 1:2 SHEET 3 OF 4 REV T3

LOC	DIST	REVISIONS					
A	66	P	LTM	DESCRIPTION	DATE	DWN	APVD
		-	-	SEE SHEET 1	-	-	-

FEED TYPE MECHANICAL

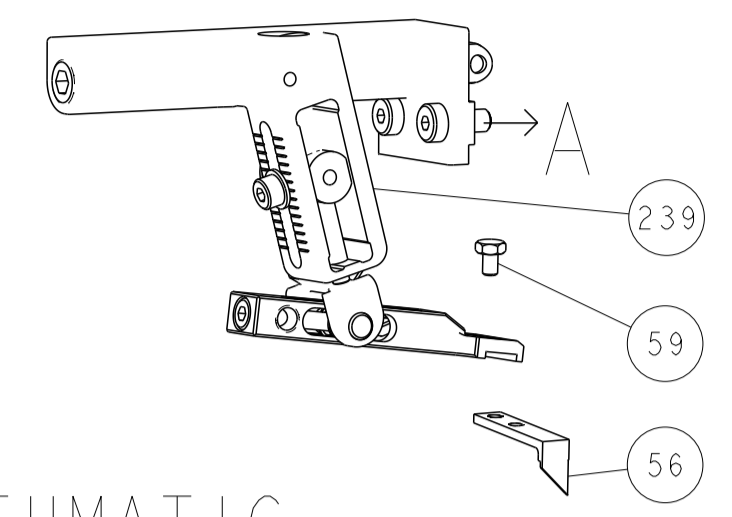

PNEUMATIC

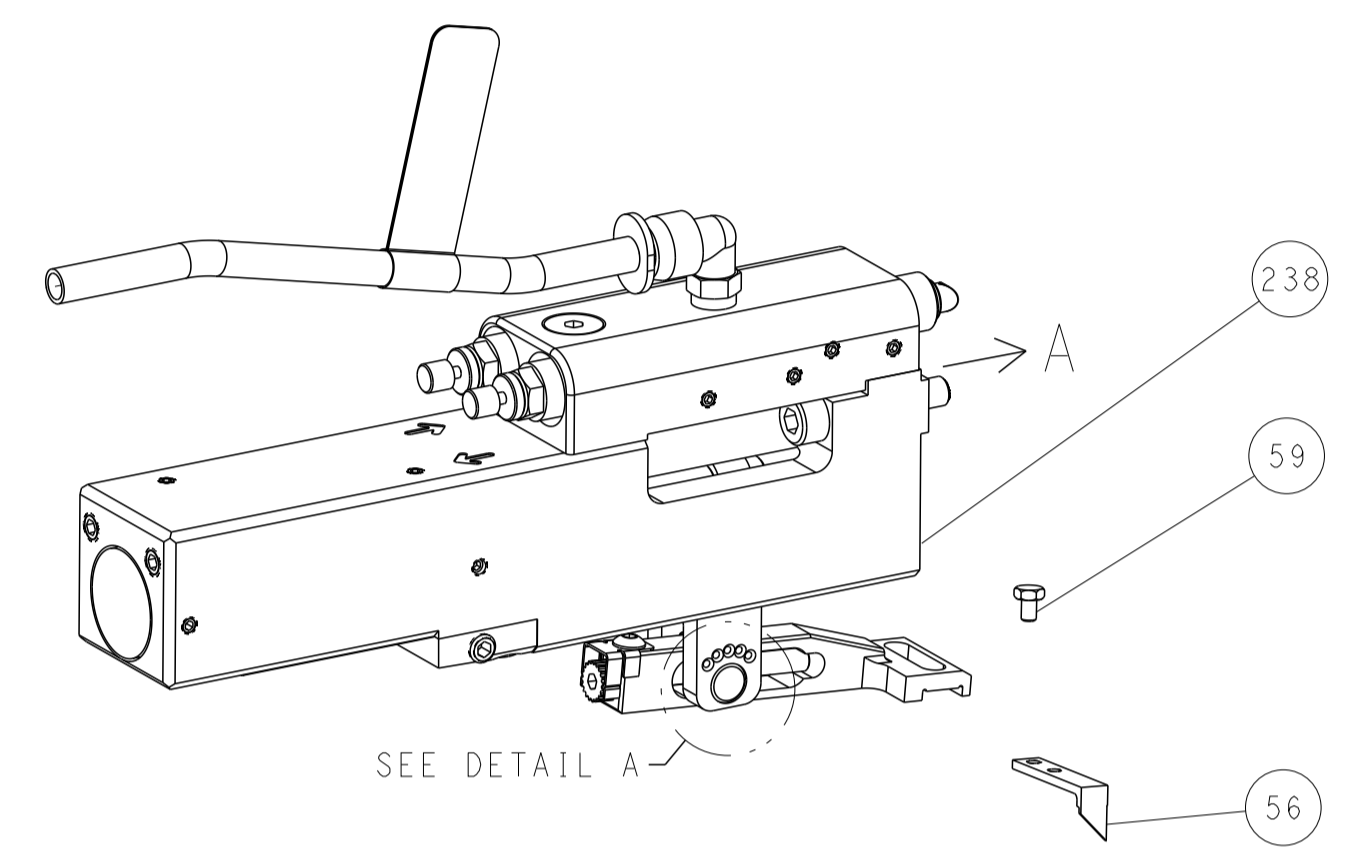

FEED SPRING SETTING POSITION (SHOWN FROM REAR SIDE)

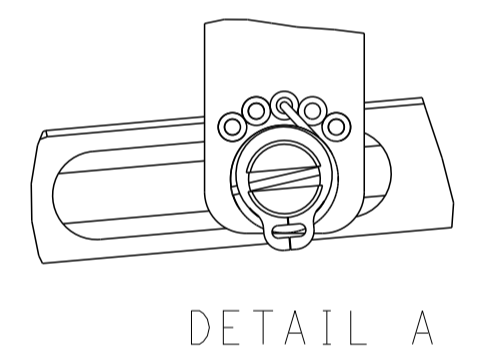

CAM POSITIONS

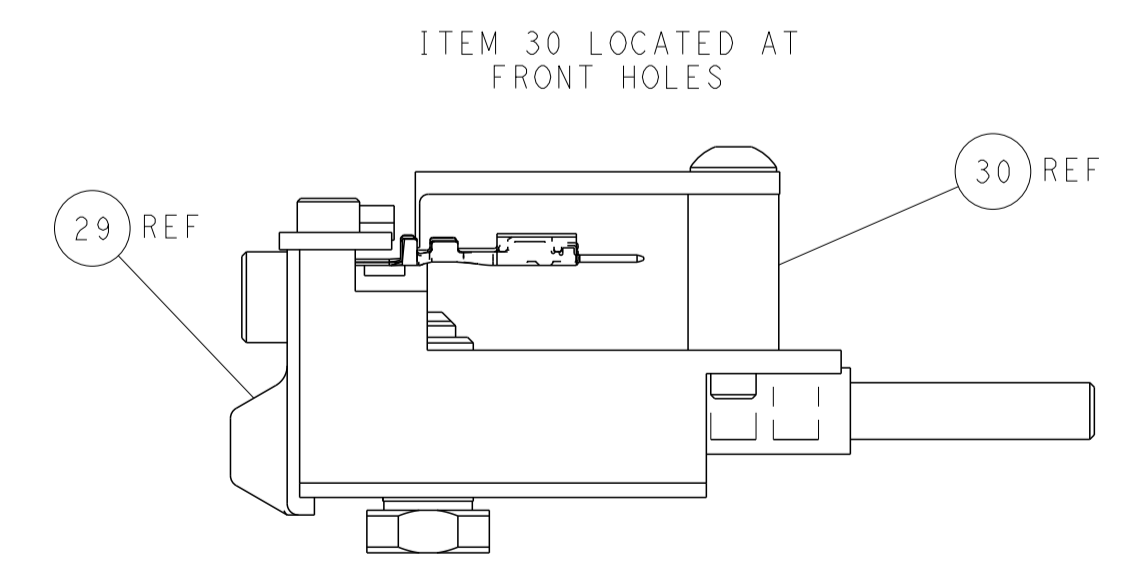
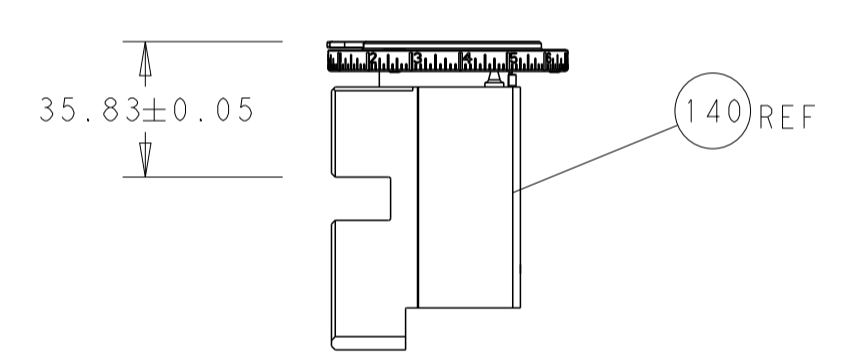
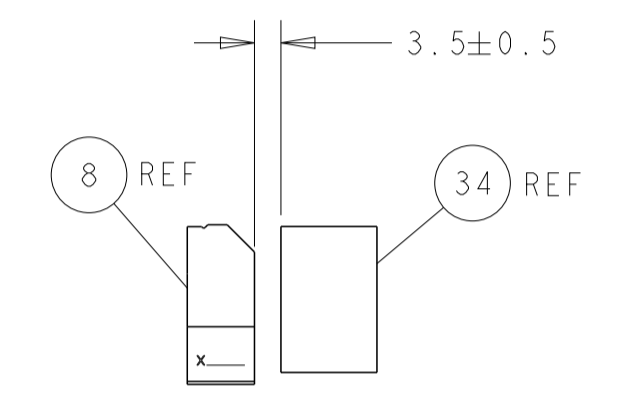
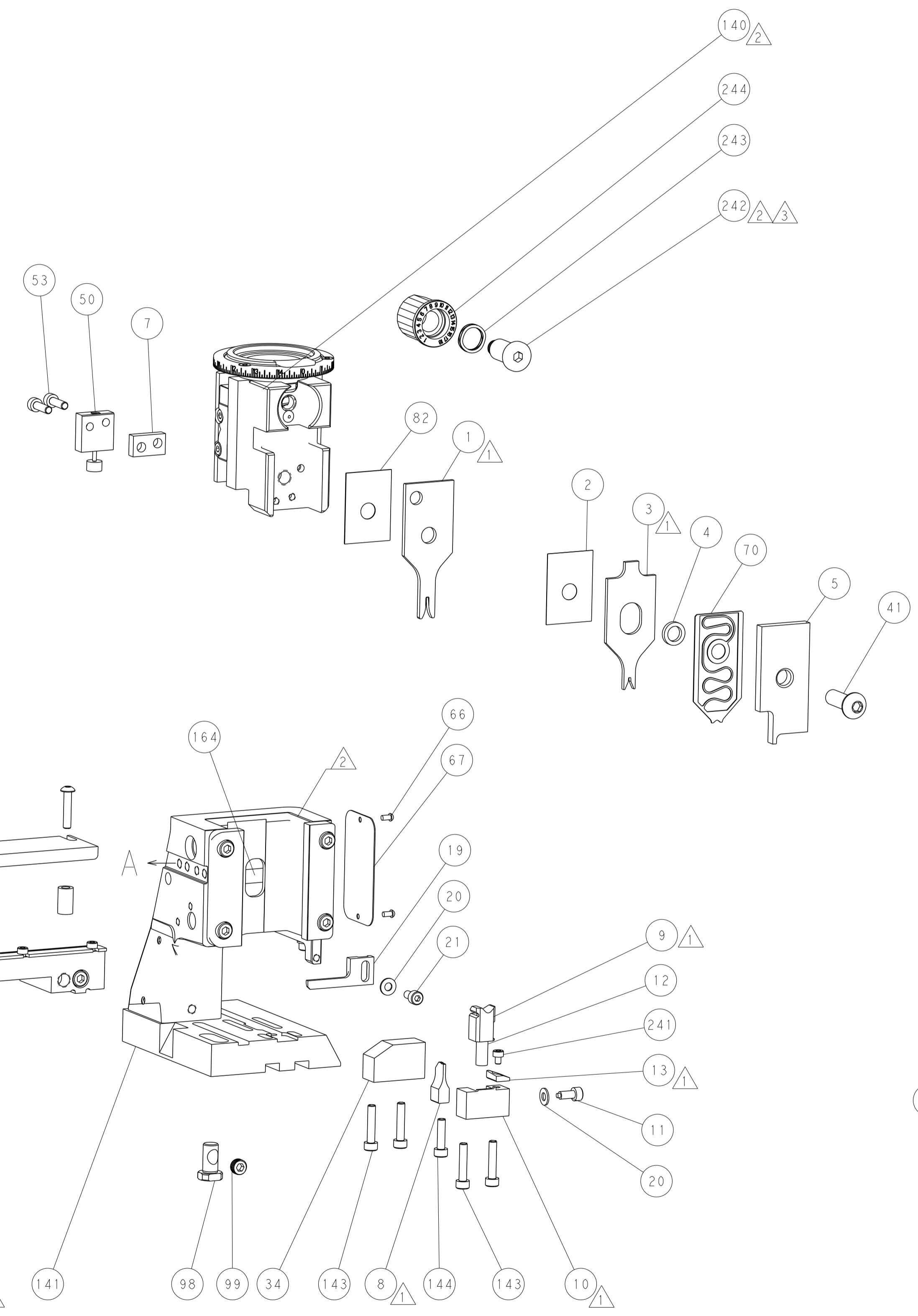
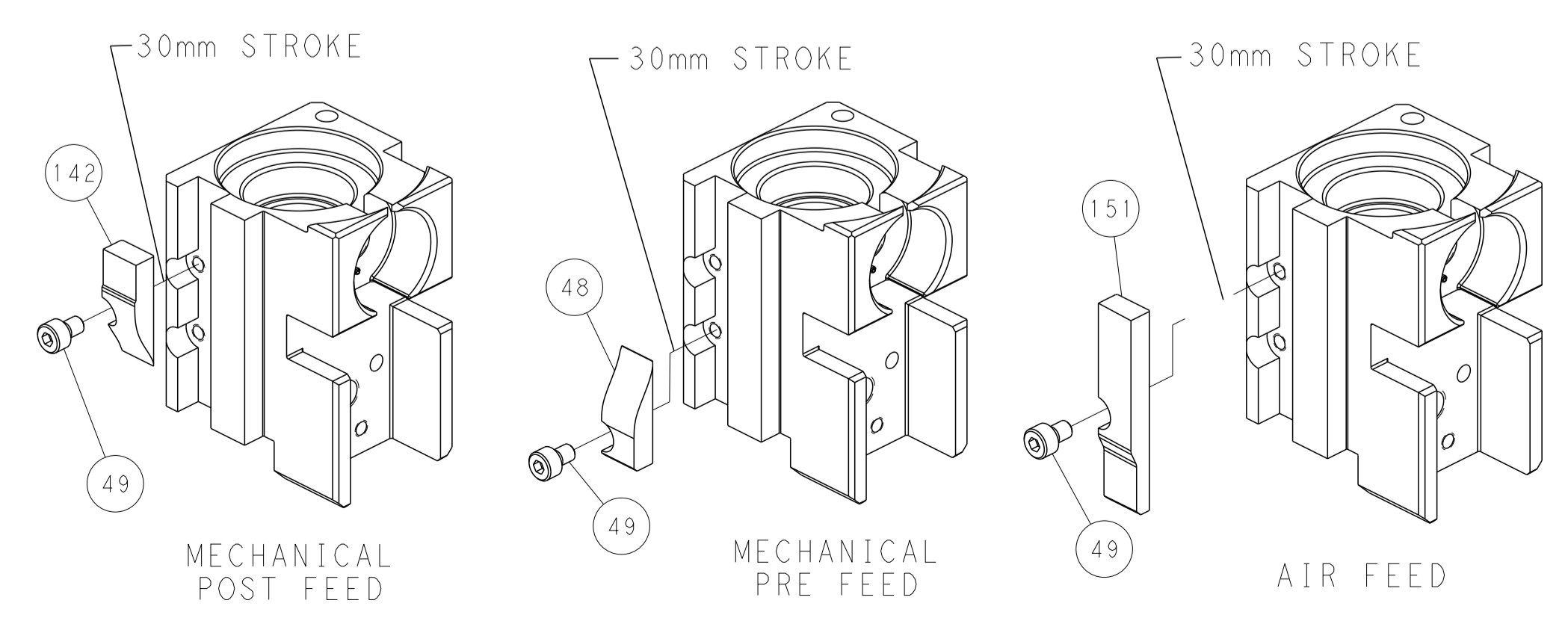

PACIFIC VERSION
 Shown on sheets 3 of 4 & 4 of 4
 (Atlantic version shown on sheets 1 of 4 & 2 of 4)

<small>THIS DRAWING IS UNPUBLISHED. RELEASED FOR PUBLICATION 2011. IT IS THE PROPERTY OF TYCO ELECTRONICS CORPORATION. IT IS TO BE USED ONLY FOR THE PURPOSES AND IN THE MANNER SPECIFIED BY THE DRAWING. IT IS TO BE RETURNED TO TYCO ELECTRONICS CORPORATION UPON COMPLETION OF THE PROJECT. NO REPRODUCTION OR DISTRIBUTION IS TO BE MADE WITHOUT THE WRITTEN PERMISSION OF TYCO ELECTRONICS CORPORATION.</small>		DWN: B. WEAVER 11OCT2011 CHK: G. HOFFNER 11OCT2011 APVD: G. RILEY 11OCT2011	NAME: TE Connectivity Harrisburg, PA 17105-3608
DIMENSIONS: mm TOLERANCES UNLESS OTHERWISE SPECIFIED: 0 PLC ± 1 PLC ± 2 PLC ± 3 PLC ± 4 PLC ± ANGLES FINISH ±	MATERIAL:	PRODUCT SPEC: APPLICATION SPEC: WEIGHT:	SIZE: A1 CAGE CODE: 00779 DRAWING NO: 2151494 SCALE: 1:2 SHEET: 4 OF 4 REV: 3