

# SPECIFICATIONS

PARAMETERS	VALUES	UNITS
RATED INPUT POWER	4	W
MAX INPUT POWER	5	W
IMPEDANCE	8 ± 15%	OHM
OUTPUT SPL @ 1W/0.5M (AT 1.0, 1.4, 1.7, 2.0 kHz)	95 ± 3	dBA
DISTORTION (MAX.)	5%	-
RESONANT FREQUENCY	230 ± 20%	Hz
FREQUENCY RANGE	230 ~ 12,000	Hz
HOUSING MATERIAL	METAL	-
CONE MATERIAL	TREATED PAPER	-
MAGNET MATERIAL	FERRITE	-
OPERATING TEMPERATURE	-20 ~ +50	°C
WEIGHT	204	grams

THIS DOCUMENT CONTAINS DATA PROPRIETARY TO PROJECTS UNLIMITED, INC. ANY USE OR REPRODUCTION, IN ANY FORM, WITHOUT PRIOR WRITTEN PERMISSION OF PROJECTS UNLIMITED, INC. IS PROHIBITED.  
©2003, Projects Unlimited Inc.

# REVISION HISTORY

LTR	DESCRIPTION	DATE	APPROVED
-	RELEASED FROM ENGINEERING	9/12/2005	
A	REVISED RESONANT FREQ. TOLERANCE	3/16/2007	R.W.
B	REVISED TO INVENTOR 3-D DRAWING TEMPLATE	1/19/2009	B.R.
C	ADDED NOTE 5	8/12/2011	B.R.
D	REVISED HOLE TO HOLE DIMENSION	9/13/2013	M.L.
E	REVISED ROHS STATUS	9/13/2013	M.L.
F	REVISED TERMINAL DIRECTION	10/22/2020	M.V.

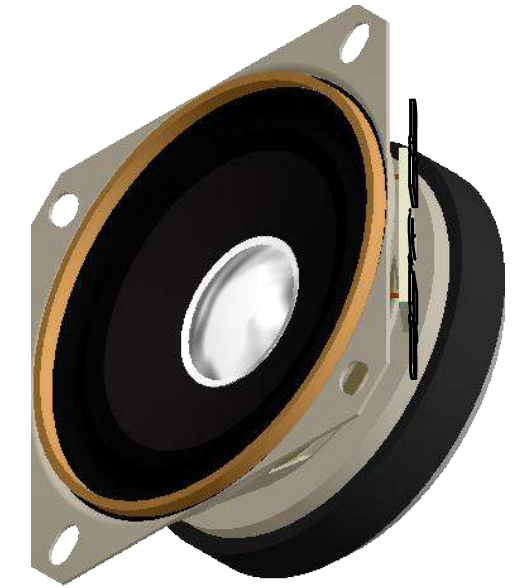
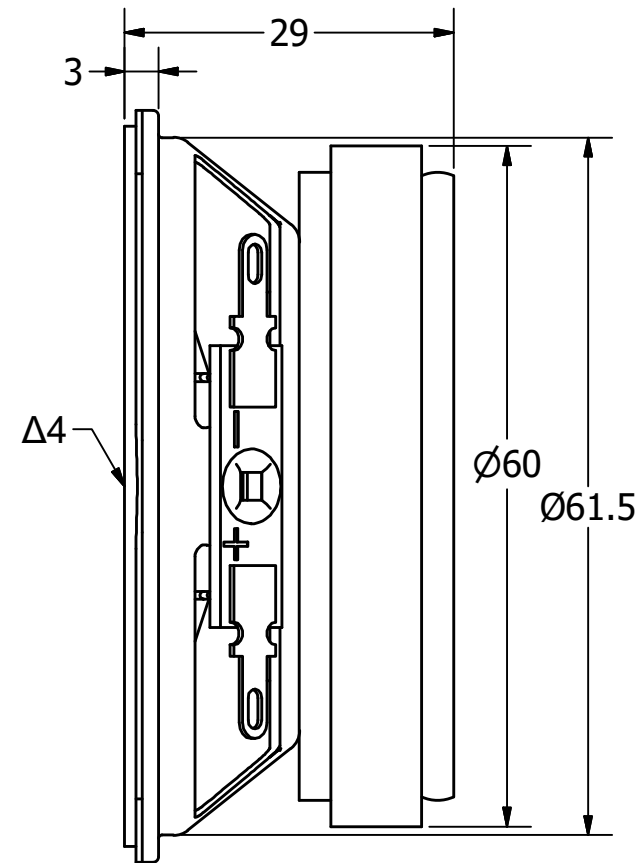
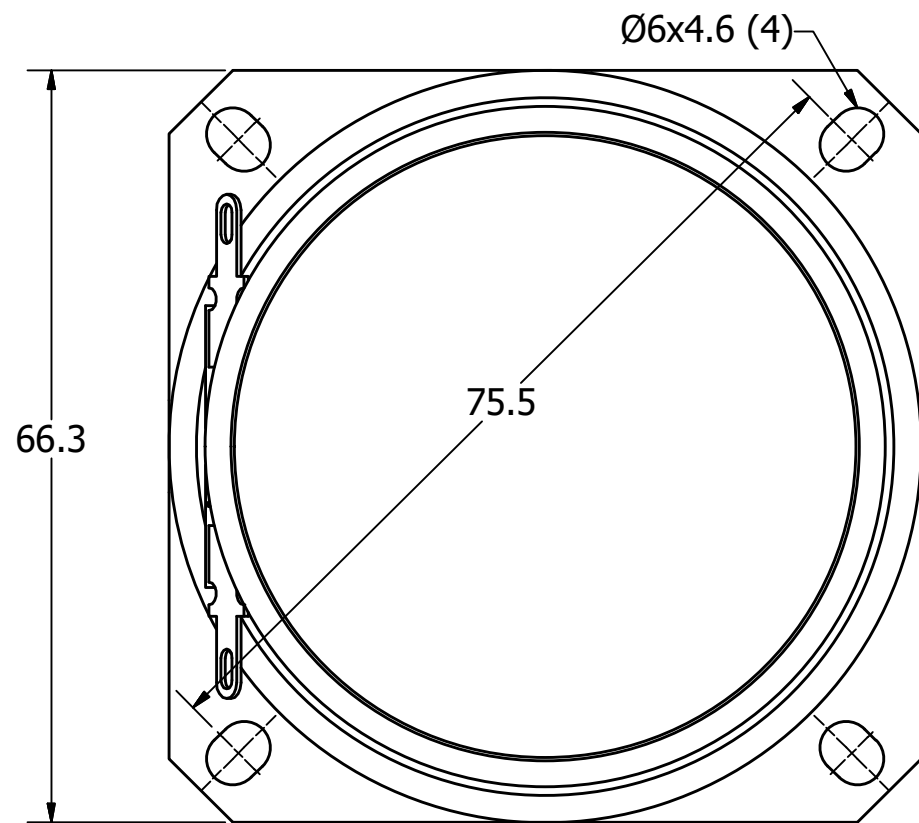

## NOTES:

1. ALL DIMENSIONS ARE IN MILLIMETERS.
2. SPECIFICATIONS SUBJECT TO CHANGE OR WITHDRAWL WITHOUT NOTICE.
3. THIS PART IS RoHS 2011/65/EU COMPLIANT.
- Δ4. CONE HAS BEEN TREATED FOR WATER RESISTANCE.
5. BASE SPEAKER PUI# AS06608PS-R.

UNLESS OTHERWISE SPECIFIED: DIMENSIONS ARE IN MILLIMETERS, TOLERANCES ARE ±0.5 AND ANGLES ARE ±3°.	SIZE <b>A3</b>	Designed by	Date	Checked by	Date	Approved by	Date	Drawn Date
		J.A.F.	9/12/2005	B.R.	9/12/2005	E.P.	9/12/2005	1/19/2009
AS06608PS-WR-R.idw				<b>AS06608PS-WR-R</b>			<b>Speaker</b>	
							Edition	Sheet
							-	1 / 1