

**Order Number**  
**213069-4500**

# molex

## Application Tooling Specification

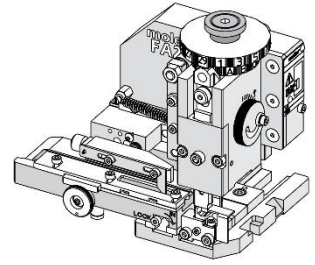

### FEATURES

- Applicator designed to industry-standard mounting and 135.80mm (5.346") shut height
- Quick setup time; plus, the crimp height, track and feed adjustments can be set without removing the applicator from the press
- Fine adjustment allows users to achieve target with little effort by adjusting in increments of 0.015mm (.0006") for conductor crimp height and 0.025mm (.001") for insulation height
- Independent adjustment rings allow users to quickly adjust the conductor or insulation crimp height without affecting each other
- Directly adapts to most automatic wire processing machines

### SCOPE

**Products:** Micro-Lock Plus 2.0 Crimp Terminals, 22-24 AWG, UL1061 Wire.

Terminal Series No.	Terminal Order No.	Wire		Insulation Diameter		Strip Length	
		Wire Type	Size	mm	In.	mm	In.
213720	213720-1000	UL1061	22 AWG 24 AWG	0.90-1.50	.079-.110	4.30-4.80	.169-.189

**DEFINITION OF TERMS**

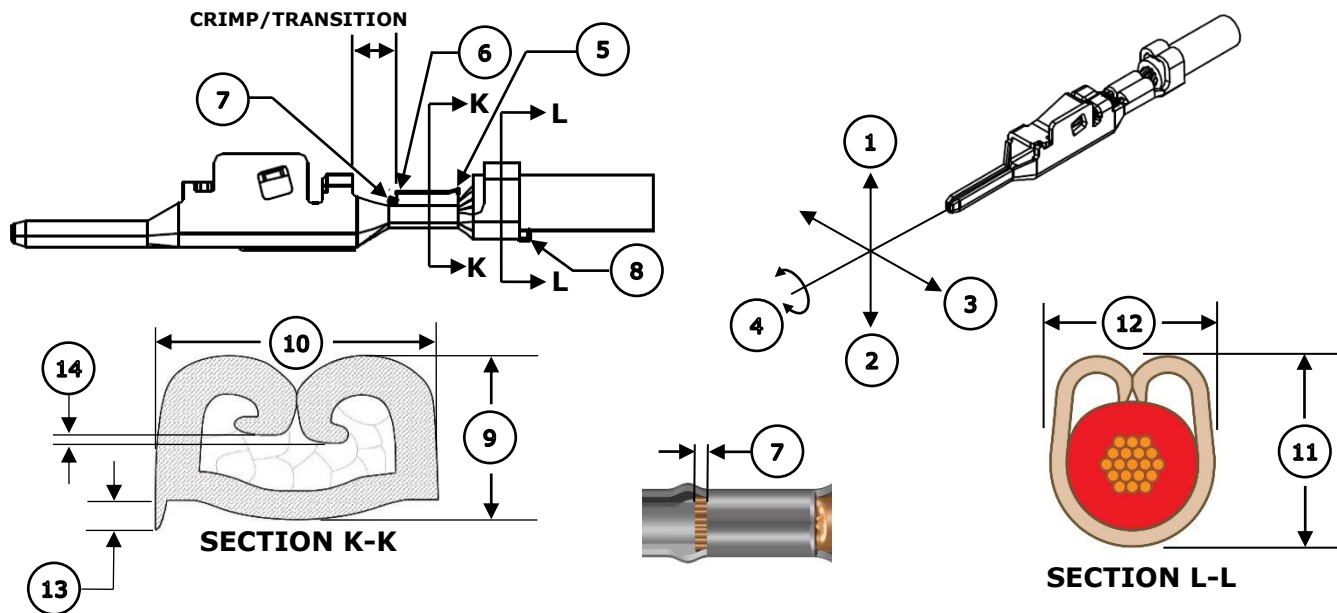

**CRIMP SPECIFICATIONS**

Feature	Requirement				
<b>1. Bend Up</b>	3° Max				
<b>2. Bend Down</b>	3° Max				
<b>3. Twist</b>	2° Max				
<b>4. Roll</b>	4° Max				
<b>5. Bell Mouth Rear</b>	0.10-0.45mm (.004-.018")				
<b>6. Bell Mouth Front</b>	Not Applicable				
<b>7. Conductor Brush</b>	0.10-0.65mm (.004-.026")				
<b>8. Cut-Off Tab</b>	0.10mm (.004") Max				
<b>Conductor Crimp</b>	<b>Wire Size</b>	<b>9. Crimp Height</b>		<b>10. Crimp Width</b>	
	22 AWG	0.78-0.83mm	.031-.033 in.	1.18-1.28mm	.046-.050 in.
24 AWG	0.70-0.75mm	.028-.030 in.			
<b>Insulation Crimp</b>	<b>Wire Size</b>	<b>11. Crimp Height</b>		<b>12. Crimp Width</b>	
	22 AWG	1.69-1.79mm	.067-.070 in.	1.54-1.64mm	.061-.065 in.
24 AWG	1.61-1.79mm	.063-.070 in.			
<b>Pull Force</b>	<b>Wire Size</b>	<b>Minimum Force</b>		To be measured with no influence from the insulation crimp.	
	22 AWG	39.2 N	8.8 lb.		
24 AWG	29.4 N	6.6 lb.			
<b>13. Conductor Anvil Flash</b>	0.075mm (.003") Max				
<b>14. Wing Dissymmetry</b>	0.20mm (.008") Max				

## NOTES

---

### Specification Notes

- It is very important that the brush length is consistently within specification for this sealed connector system to work properly.
- This applicator should only be run in a properly set up wire processor to consistently achieve the brush length.

### General Notes

1. Molex recommends that an extra perishable tooling kit be maintained at your facility.
2. Verify tooling alignment by hand cycling the press and applicator before crimping under power. Check that all screws are tight.
3. Slugs, terminals, dirt and oil should be kept clear of the work area.
4. Wear safety glasses at all times.
5. For recommended maintenance, refer to the FA2 manual (TM-638080200).
6. Molex recommends crimping stranded copper wire only.

## WARNINGS

---

**CAUTION:** This applicator must be installed in a press with a standard shut height of 135.80mm (5.346"). Tooling damage could result at a lower setting.

**CAUTION:** To prevent injury, never operate this applicator without the guards supplied with the press or wire-processing machine in place. Reference the press or wire processing manufacturer's instruction manual.

**CAUTION:** Molex tooling crimp specifications are valid only when used with Molex terminals and tooling manufactured by Molex and sold by Molex or authorized distributors ("Molex Tooling"). When using tooling other than Molex Tooling with Molex-specific connector systems listed in our ATS documents, the Molex Tooling qualification does not apply, and the responsibility for full qualification of the connector system is that of the customer. Molex accepts no liability for connector performance or tooling support where tooling other than Molex Tooling is used or where Molex Tooling is modified.

**PARTS LIST**

<b>FA2 Applicator 213069-4500</b>				
<b>Item</b>	<b>Order No.</b>	<b>Engineering No.</b>	<b>Description</b>	<b>Quantity</b>
<b>Perishable Tooling</b>				
	213069-4570	213069-4570	Tool Kit (All "Y" Items)	Ref
1	200220-1510	200220-1510	Insulation Punch	1 Y
2	200216-1205	200216-1205	Conductor Punch	1 Y
3	200221-1402	200221-1402	Insulation Anvil	1 Y
4	200217-1207	200217-1207	Conductor Anvil	1 Y
5	63443-0136	63443-0136	Cut-Off Plunger	1 Y
6	63443-0119	63443-0119	Cutting Insert	1 Y
<b>Non-Perishable Components</b>				
7	63443-0118	63443-0118	Front Plunger Retainer	1
8	01124-1067	4996-4	Cut-Off Plunger Spring	1
9	63443-0117	63443-0117	Front Scrap Chute	1
10	63443-2207	63443-2207	Coarse Spacer	1
11	63443-2807	63443-2807	Front Plunger Striker	1
12	63443-2905	63443-2905	Wire Hold Down Plunger	1
13	63600-0021	63600-0021	Wire Hold Down Spring	1
14	63600-5775	63600-5775	Nose Hold Down Shank	1
15	63700-0992	63700-0992	Terminal Hold Down Plunger Spring	1
16	63443-7338	63443-7338	Terminal Hold Down	1
17	63443-4716	63443-4716	Terminal Guide	1
18	63808-0220	63808-0220	Hold Down Block	1
19	63808-0229	63808-0229	Bend Adjust Dial	1
20	63443-4410	63443-4410	Feed Cam	1
21	63443-7315	63443-7315	Terminal Hold Down Plunger	1
22	63443-7316	63443-7316	Terminal Hold Down Retainer	1
23	63443-7317	63443-7317	Terminal Hold Down Plate	1
24	63808-0249	63808-0249	Feed Pawl	1
25	203045-0030	203045-0030	Feed Pawl Spring	1
<b>Frame</b>				
26	63808-0200	63808-0200	Applicator Core	1
27	63808-0197	63808-0197	Mechanical Feed Assembly	1
28	63808-0191	63808-0191	Track Assembly	1
<b>Hardware</b>				
29	—	—	M2.5 x 4 SHCS	2*
30	—	—	M3 Hex Nut	1*
31	—	—	M3 Flat Washer Hard	1*
32	—	—	M3 Inner Tooth Lock Washer	1*
33	—	—	M3 x 6 BHCS	2*
34	—	—	M3 x 10 SHCS	2*
35	—	—	M3 x 12 SHCS	4*
36	—	—	M4 x 5 SSS	1*
37	—	—	M4 x 6 SHCS	1*
38	—	—	M4 x 8 SHCS	2*
39	—	—	M4 x 45 SHCS	2*
40	—	—	M5 Hex Jam Nut	1*
41	—	—	M5 x 12 Long Cup Point SSS	1*
*Fastener parts can be purchased through most industrial suppliers by using the description in the table above.				

**ASSEMBLY DRAWING**

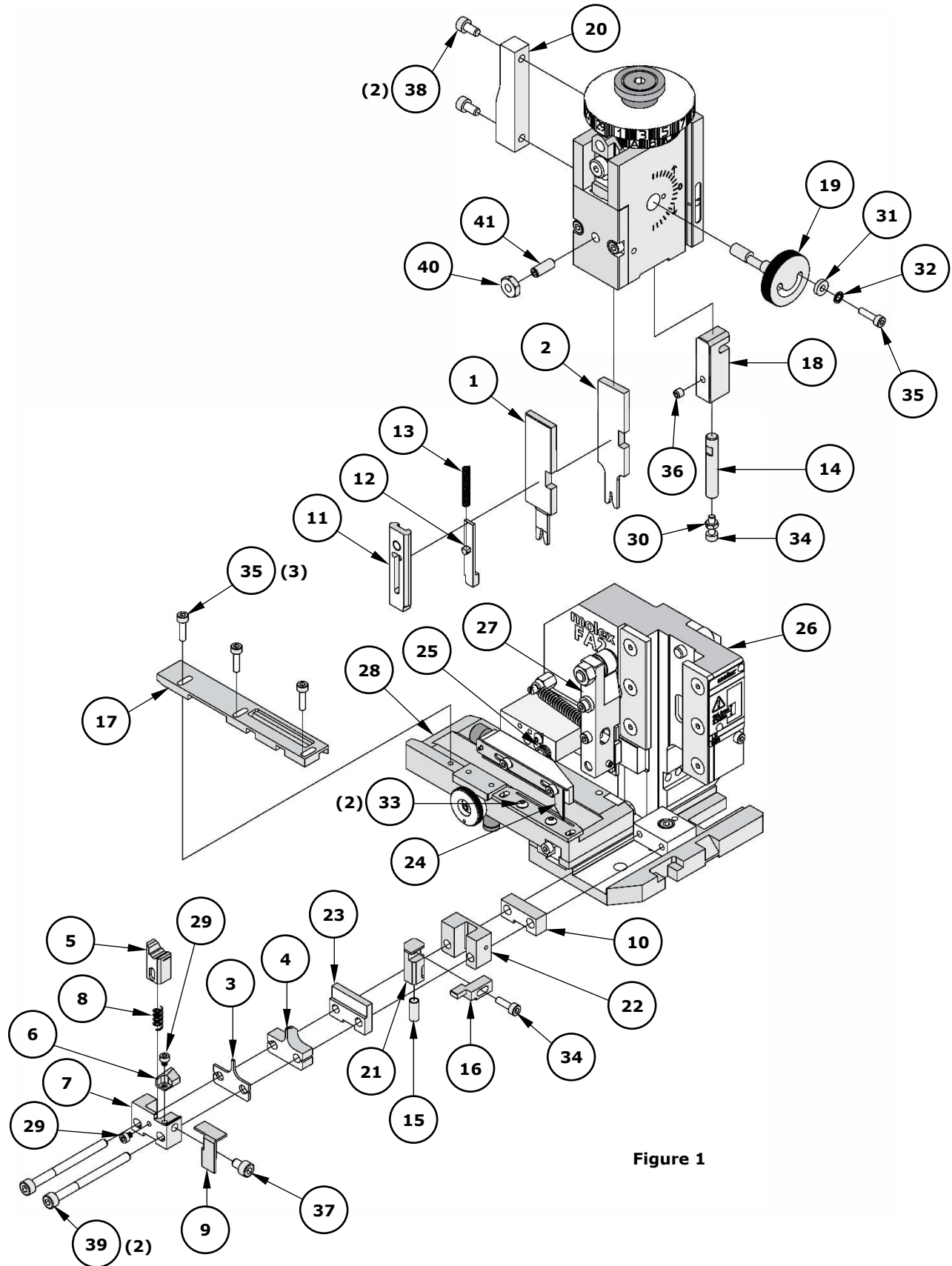

Figure 1

## FACTORY SETTINGS

### Feed Pawl Assembly

The FA2 applicator number 213069-4500 ships with the following factory settings. See Figure 2:

- The feed pawl shaft and M3 screw that holds the feed pawl spring are in position 2.
- The pin is in position B.

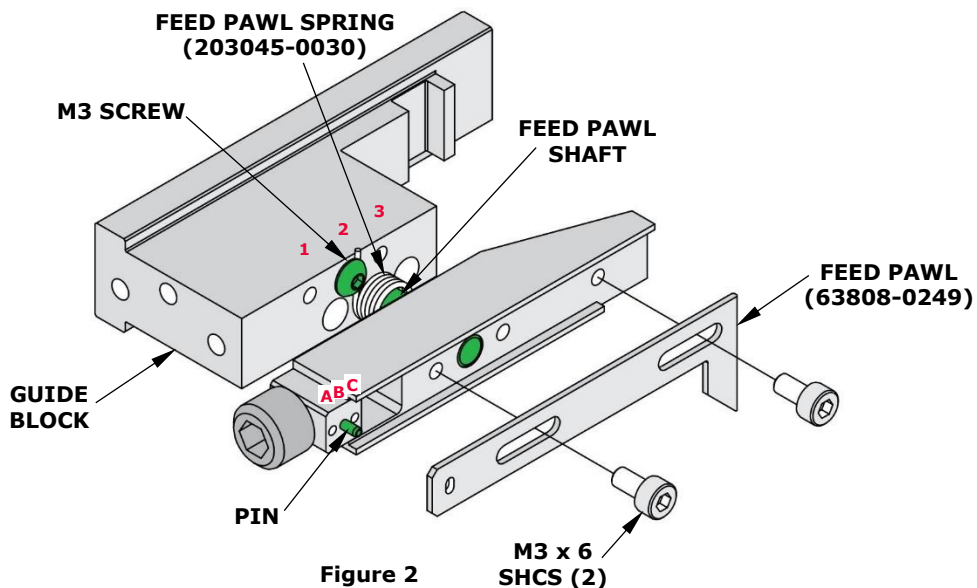

**Note:** Each applicator is configured and tested by Molex prior to shipping, and the above settings were used to produce the included sample crimps.

### Third Dial/Ram Assembly

○ Indicates item number on the Parts List and Assembly Drawing

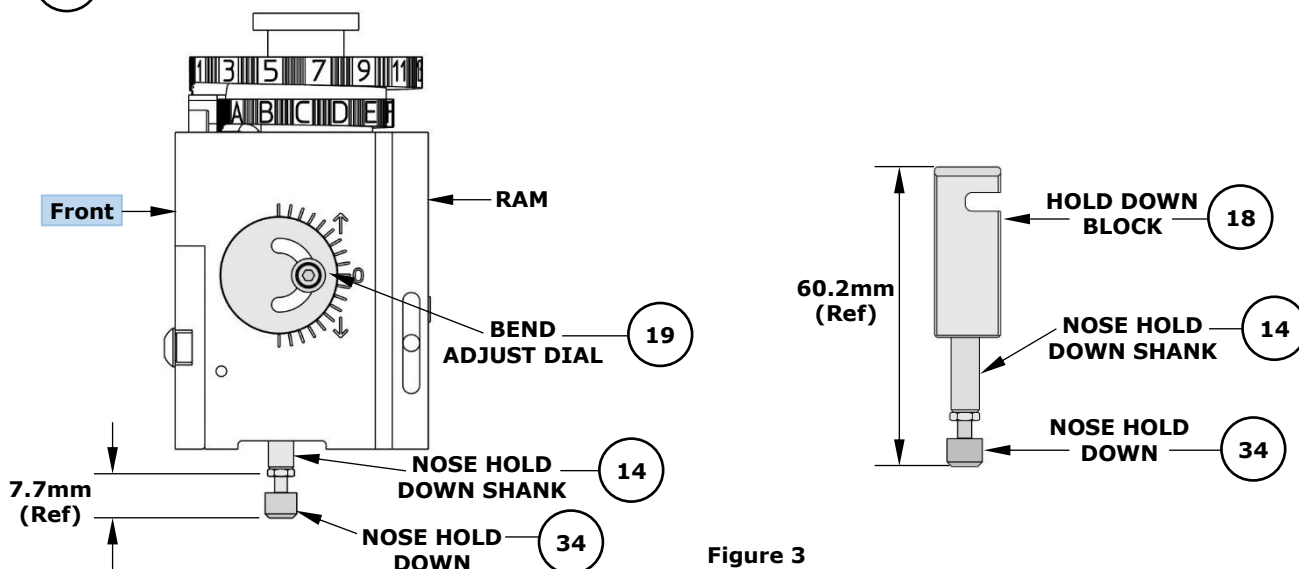

**Note:** The above dimensions were measured during setup and are included as a reference only. Additional adjustments may be required before crimping for production.

### Mounting Datum Location

This applicator was assembled and tested by Molex with the mounting datum in the location shown in Figure 4. Do not remove the mounting datum.

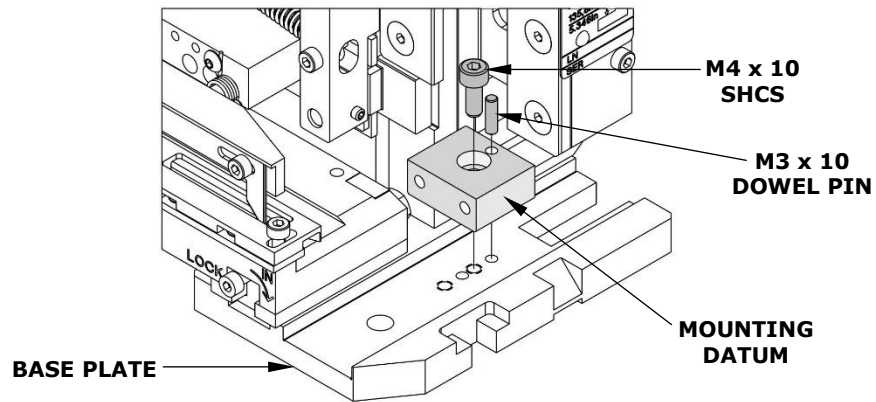

Figure 4

### Application Tooling Support

**Phone:** (402) 458-TOOL (8665)

**E-Mail:** [toolingsupport@molex.com](mailto:toolingsupport@molex.com)

**Website:** [www.molex.com/applicationtooling](http://www.molex.com/applicationtooling)

Molex is a registered trademark of Molex, LLC in the United States of America and may be registered in other countries; all other trademarks listed herein belong to their respective owners.