

DRAWING MADE IN THIRD ANGLE PROJECTION

THIS DRAWING IS UNPUBLISHED. RELEASED FOR PUBLICATION .18
 COPYRIGHT © BY AMP INCORPORATED. ALL INTERNATIONAL RIGHTS RESERVED.

NO		LBR		DTSY		REVISIONS		DATE	APPD
ZONE	LTR	DESCRIPTION	DATE	APPD					
23	BD	35	P	P	N	REDRAWN	8-27-91	-	
			L	L	P	REV PER ECN 805454	05/28/92	KB	

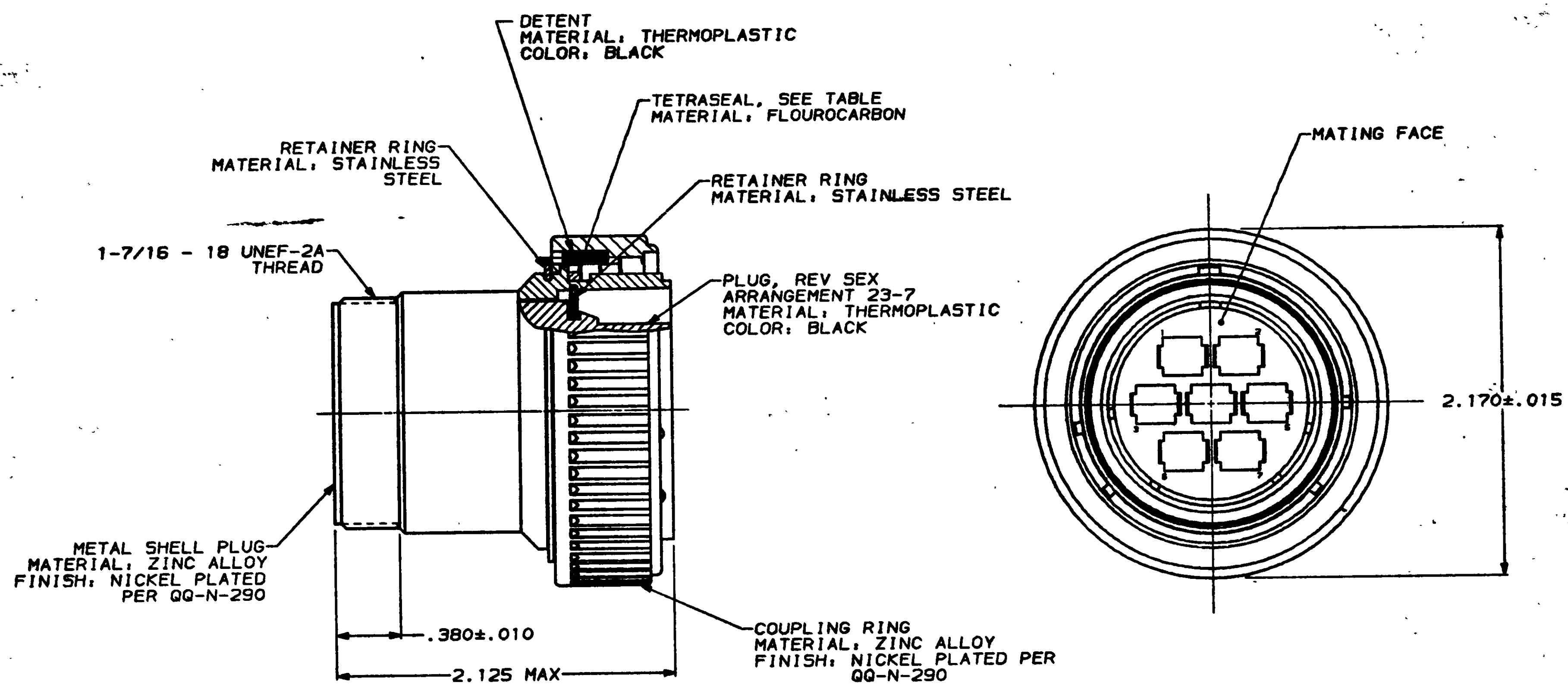

YES	208484-3
NO	208484-1
TETRASEAL	PART NUMBER

- 208484-1 MATES WITH AMP RECEPTACLE 208485-1 OR -2.
208484-3 MATES WITH AMP RECEPTACLE 208485-1 ONLY.
- AMP PART NUMBER AND DATE CODE TO BE LOCATED
ON COUPLING RING.

DO NOT SCALE PRINT. UNLESS SPECIFIED DIMENSIONS IN INCHES TOLERANCES ON: 2 PLC DEC * - 3 PLC DEC * - ANGLES * -	DR 8-27-91 R.LEE BG	AMP Incorporated Harrisburg, PA 17105-3808
MATERIAL	CHK 4-20-92 W.S.LENKER	
SEE CALLOUT	APPD 4-20-92 K.BEAVER	
FINISH	APPD 4-20-92 C.ROHDE	NAME
SEE CALLOUT	PRODUCT SPEC 108-10040	PLUG ASSEMBLY, REV SEX, SERIES 3, 28-7, CMC
	APPLICATION SPEC	SIZE
	WEIGHT	C 00779
		DRAWING NO
		208484
		SCALE
		2:1
		SHEET
		1 OF 1

CUSTOMER DRAWING