

THIS DRAWING IS UNPUBLISHED  
 RELEASED FOR PUBLICATION 2018  
 © COPYRIGHT 2018 BY -TE CONNECTIVITY ALL RIGHTS RESERVED.

REVISIONS					
P	LTR	DESCRIPTION	DATE	DWN	APVD
	A	REVISED PER PCN E-18-009438	14JUN2018	SS	DM

MIN. INSUL. O.D.	MAX. INSUL. O.D.	WIRE RANGE [mm <sup>2</sup> ] REF ONLY
.053 [1.35]	.120 [3.05]	14-20 AWG [2.0-0.50]

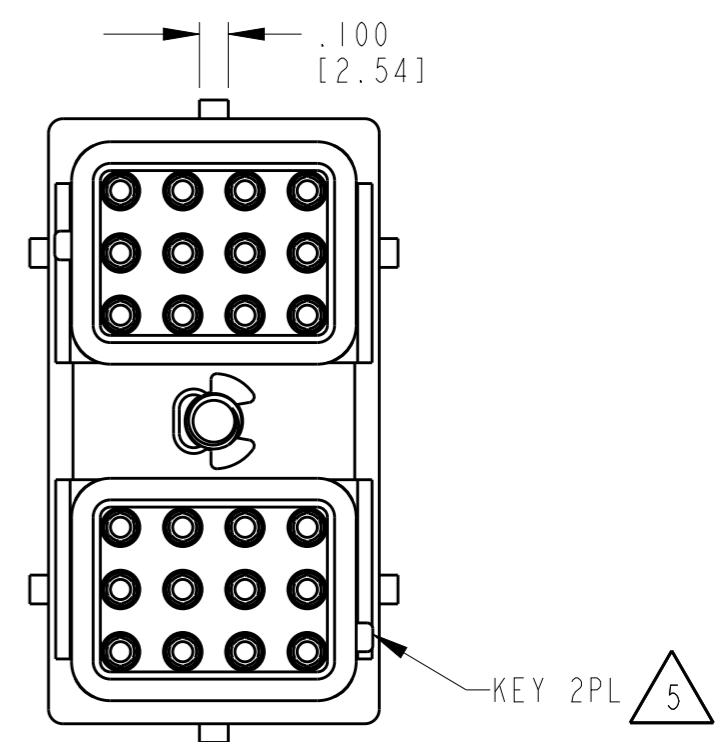
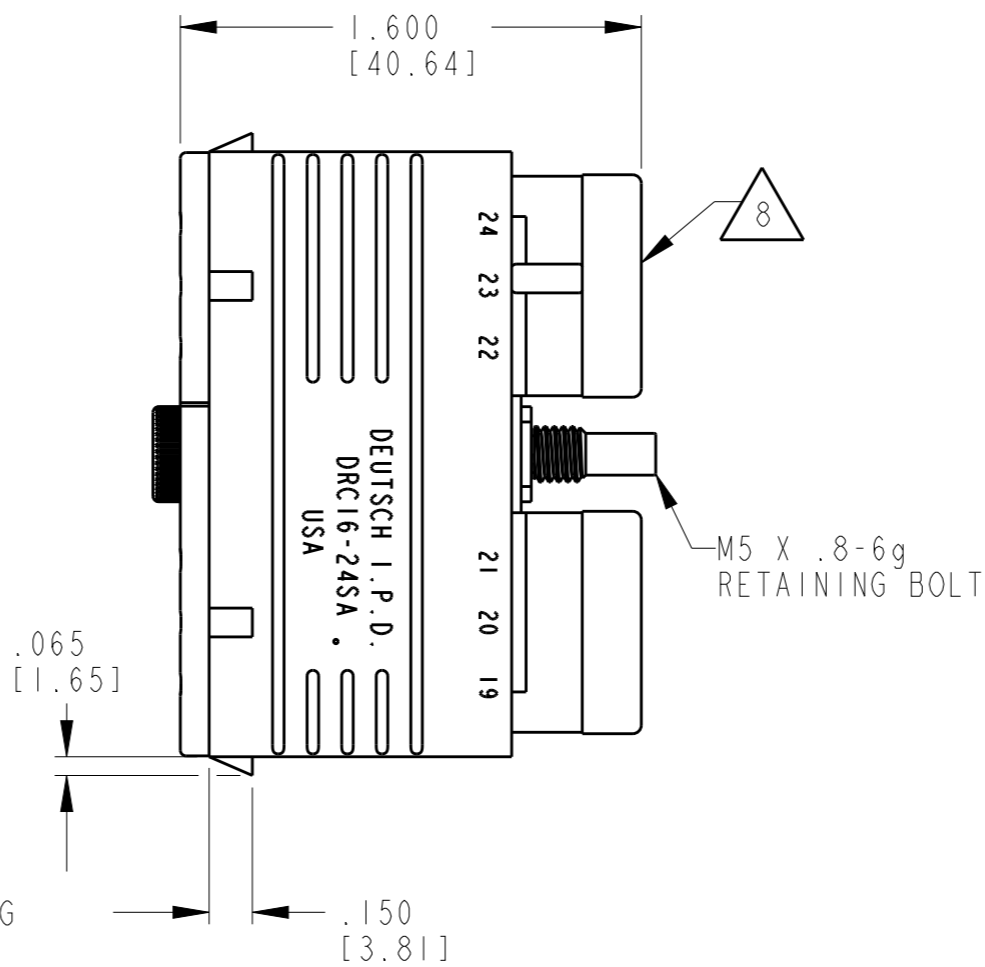
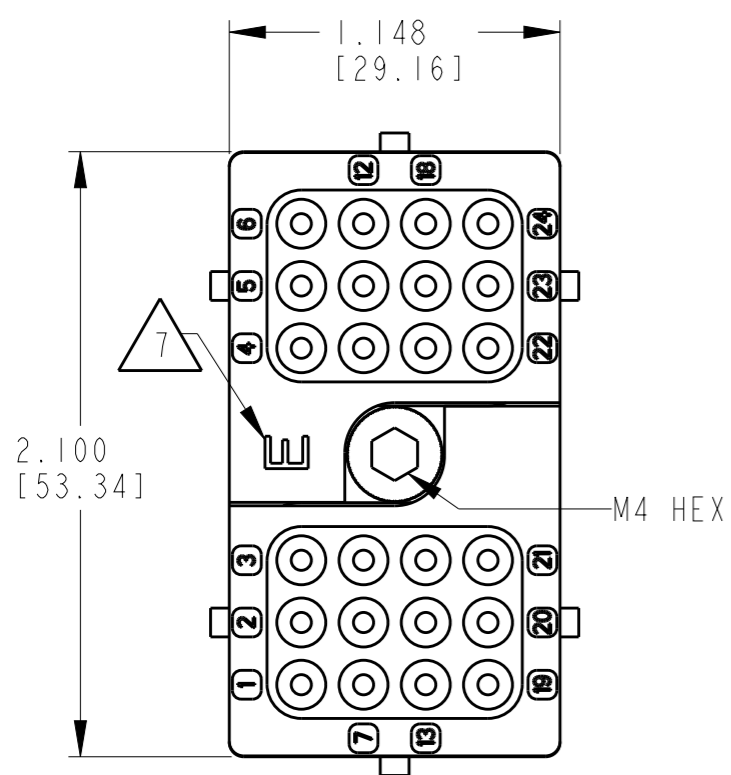

- 8 PART MODIFICATION: INTERFACE SEALS ARE BONDED TO PLUG
- 7 E-SEAL IS IDENTIFIED BY LETTER "E" MARK.
- 6. MATING TORQUE REQUIREMENT: 25-28 IN-LB [2.82-3.13 Nm].
- 5. SEE SHEET 2 FOR OTHER KEY ARRANGEMENTS.
- 4 MATERIAL- PLUG: PPS GF40 (BLACK)  
 SEAL/GROMMET: VMQ (RED-ORANGE)  
 CLIP: STEEL, UNPLATED  
 BOLT: STAINLESS STEEL WITH SILVER PLATING AND MAY TARNISH

3. THIS PLUG MATES WITH DRC10-24PX-XXXX; DRC12-24PX-XXXX; DRC13-24PX-XXXX; AND DRC14-24PX-XXXX RECEPTACLE. (X=A,B,C,D KEYS; XXXX=ALL MODIFICATIONS). CONSULT FACTORY FOR MODS.

2 FOR CONTACTS AND WIRE PERFORMANCE AND APPLICATION CHARACTERISTICS, SEE ENVELOPE DRAWING 0425-015-0000.

1. PLUG SUPPLIED WITH DUST CAP. PN 0515-005-2405 (NOT SHOWN).

NOTES: UNLESS OTHERWISE SPECIFIED

TE INTERNAL PN	DEUTSCH PN
DRC16-24SAE-P013	DRC16-24SAE-P013
DRC16-24SBE-P013	DRC16-24SBE-P013
DRC16-24SCE-P013	DRC16-24SCE-P013
DRC16-24SDE-P013	DRC16-24SDE-P013

THIS DRAWING IS A CONTROLLED DOCUMENT.		DWN D.MEYER 08APR2002		
DIMENSIONS: INCHES [mm]		CHK D.MEYER 08APR2002		
TOLERANCES UNLESS OTHERWISE SPECIFIED:		APVD R.FEED 10APR2002		
0 PLC ± 1 PLC ± 2 PLC ± 3 PLC ±.025 [0.64] 4 PLC ± ANGLES ±0°30'0"		PRODUCT SPEC -		
MATERIAL		FINISH	NAME PLUG 24 SIZE 16 KEYS: A,B,C,D E SEAL COLOR: BLACK DRC SERIES	
4			SIZE A3	CAGE CODE 4AFU8
			DRAWING NO. DRC16-24SXE-P013	RESTRICTED TO -
			CUSTOMER DRAWING	SCALE 1.5:1
				SHEET 1 OF 2
				REV A

REVISIONS					
P	LTR	DESCRIPTION	DATE	DWN	APVD
-	-	SEE SHEET 1	-	-	-

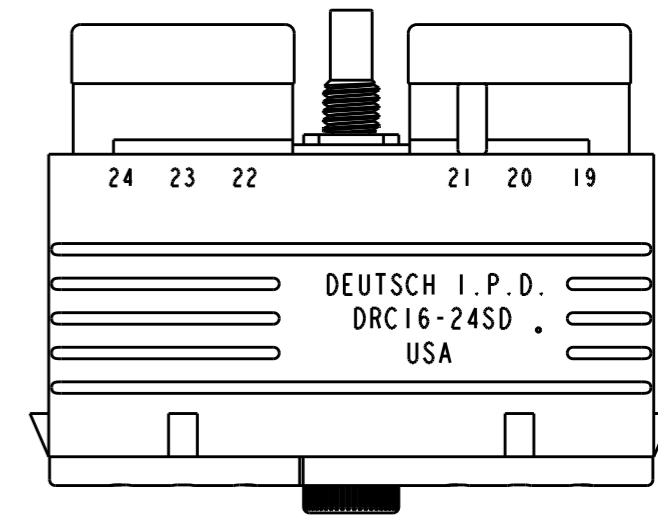
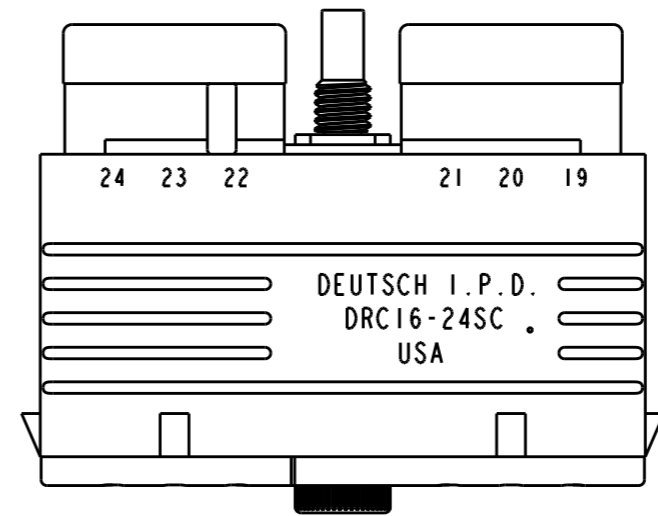
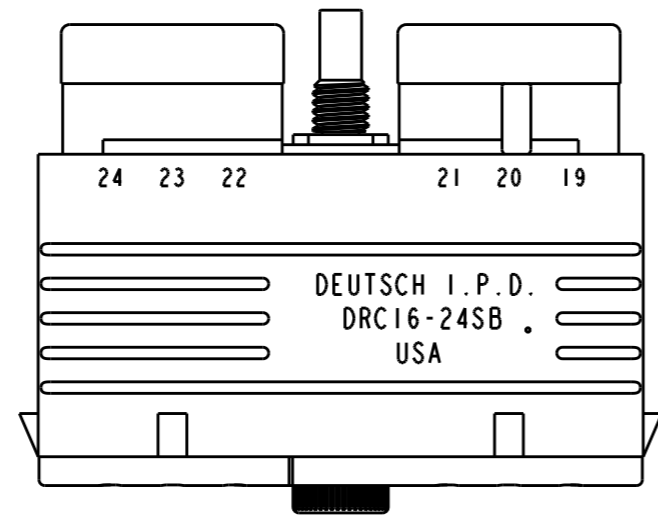
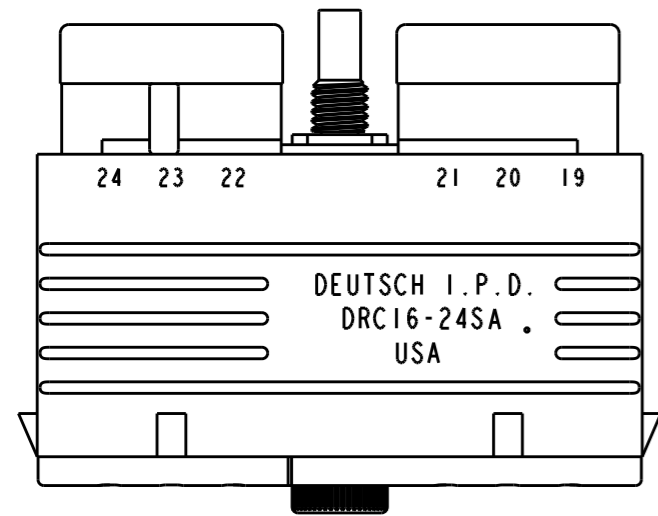
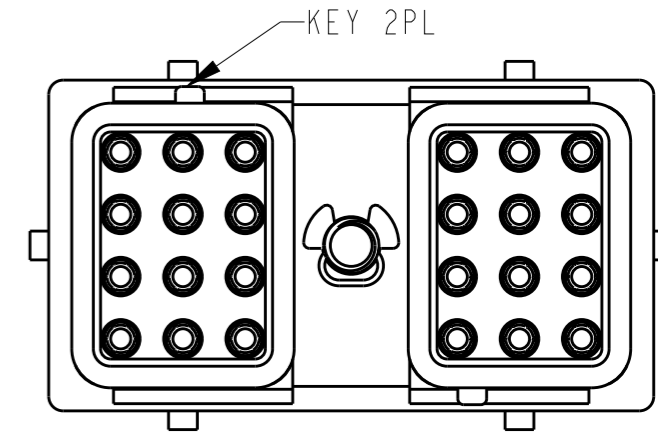
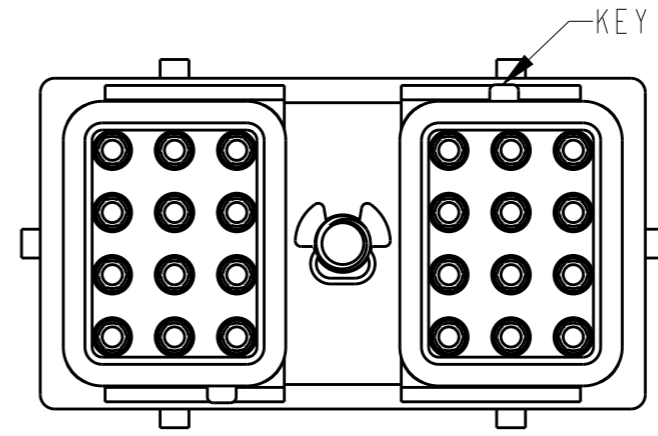
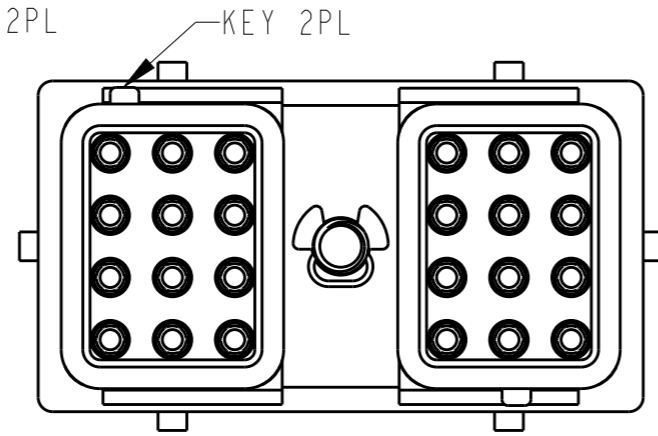
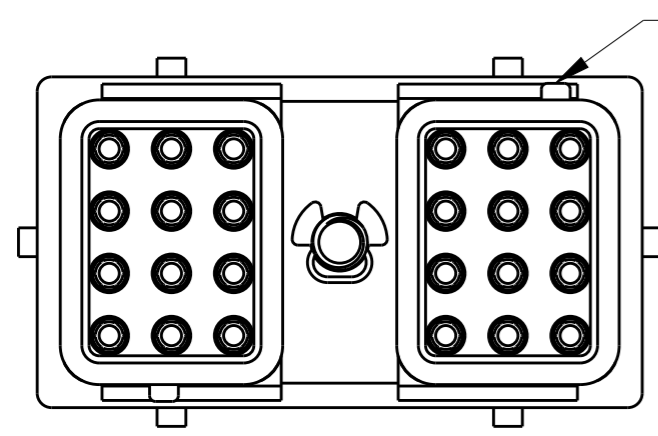

**DRC16-24SAE-P013**  
KEY: -A-

**DRC16-24SBE-P013**  
KEY: -B-

**DRC16-24SCE-P013**  
KEY: -C-

**DRC16-24SDE-P013**  
KEY: -D-

THIS DRAWING IS A CONTROLLED DOCUMENT.		DWN D. MEYER 08APR2002		NAME PLUG 24 SIZE 16 KEYS: A,B,C,D E SEAL COLOR: BLACK DRC SERIES		
DIMENSIONS: INCHES [mm]		CHK D. MEYER 08APR2002		SIZE A3	CAGE CODE 4AFU8	DRAWING NO DRC16-24SXE-P013
TOLERANCES UNLESS OTHERWISE SPECIFIED: 0 PLC ± 1 PLC ± 2 PLC ± 3 PLC ±.025 [0.64] 4 PLC ± ANGLES ±0°30'0"		APVD R. REED 10APR2002		RESTRICTED TO	-	
MATERIAL 4		PRODUCT SPEC -		SCALE 1.5:1	SHEET 2 OF 2	REV A
FINISH		APPLICATION SPEC -	CUSTOMER DRAWING			